

# Panasonic



HYDRONICS CATALOGUE  
2024 / 2025



heating & cooling solutions



## Chillers and heat pumps, fan coils, water source heat pumps and rooftops

These new Series provide a wide variety of HVAC system solutions, to meet all of your commercial and industrial needs.

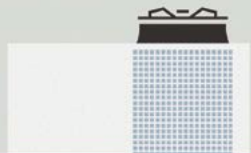



The reasons to choose Panasonic as your partner	→ 462
A wide variety of HVAC system solutions	→ 463
A wide coverage of application	→ 464
Solutions for hospitals	→ 466

<b>Air cooled chillers, heat pumps and condensing units</b>	→ 468
ECOi-W AQUA-G BLUE R290	→ 470
Quick selection guide - Air cooled chillers	→ 472
Quick selection guide - Air cooled heat pumps	→ 474
Quick selection guide - Air cooled condensing	→ 477
ECOi-W AQUA EVO H	→ 478
ECOi-W AQUA-G BLUE 50-80 H	→ 480
ECOi-W AQUA 20-40 C/H/E	→ 482
ECOi-W AQUA 45-125 C/H/E	→ 484
ECOi-W AQUA 140-210 C/H	→ 486
ECOi-W AQUA-Z 50-170 C/H	→ 488
ECOi-W AQUA-Z DC 150-380 C/H	→ 490
ECOi-W AQV C/H/E	→ 492
ECOi-W VL H/E	→ 496
ECOi-W AQUA EVO 230-360 C/H/E	→ 500
ECOi-W AQUA EVO 400-800 C/H	→ 504
ECOi-W SW-N EVO 380-1260 C	→ 508

<b>Water cooled chillers, heat pumps and condenserless units</b>	→ 510
Quick selection guide - Water cooled chillers	→ 512
Quick selection guide - Water cooled heat pumps	→ 513
Quick selection guide - Water cooled condenserless units	→ 514
ECOi-W WQ 20-190 C/H/R	→ 516
ECOi-W WQ 524-1604 C/H/R	→ 518
ECOi-W WSW-N EVO 440-1550 C/H/R	→ 520

<b>Fan coil units</b>	→ 524
Quick selection guide - Fan coil units	→ 525
Fan coil comfort AC fan	→ 526
Fan coil comfort EC fan	→ 528
Fan coil cassette AC fan	→ 530
Fan coil cassette EC fan	→ 532
Fan coil wall AC fan	→ 534
Fan coil duct EC fan	→ 536
Fan coil high static duct AC fan	→ 538
Fan coil high static duct EC fan	→ 540
Fan coil controllers	→ 542

<b>Water source heat pumps</b>	→ 546
Quick selection guide - Water source heat pumps	→ 548
ECOi-LOOP 15-30 C/H · R410A	→ 550
ECOi-LOOP-N 70-135 H · R513A	→ 552
ECOi-LOOP-N EVO C/H · R513A	→ 554
ECOi-LOOP HRW H and ECOi-LOOP HRWE H · R407C	→ 556
ECOi-LOOP FS H · R407C	→ 558
ECOi-LOOP-N FS H · R513A	→ 560
Water source heat pumps control systems	→ 562

<b>Rooftops</b>	→ 564
Quick selection guide - Rooftops cooling only	→ 566
Quick selection guide - Rooftops reversible	→ 566
Energy recovery system configurations	→ 567
ECOi-RT-Z H · R32	→ 568
ECOi-RT C/H · R410A	→ 570

## The reasons to choose Panasonic as your partner

Unrivalled reliability and quality.

Panasonic solutions can be enjoyed for years to come, even in the most extreme climates.

Panasonic does not compromise on product quality, safety or durability, in order to provide the ultimate comfort when you need it most.

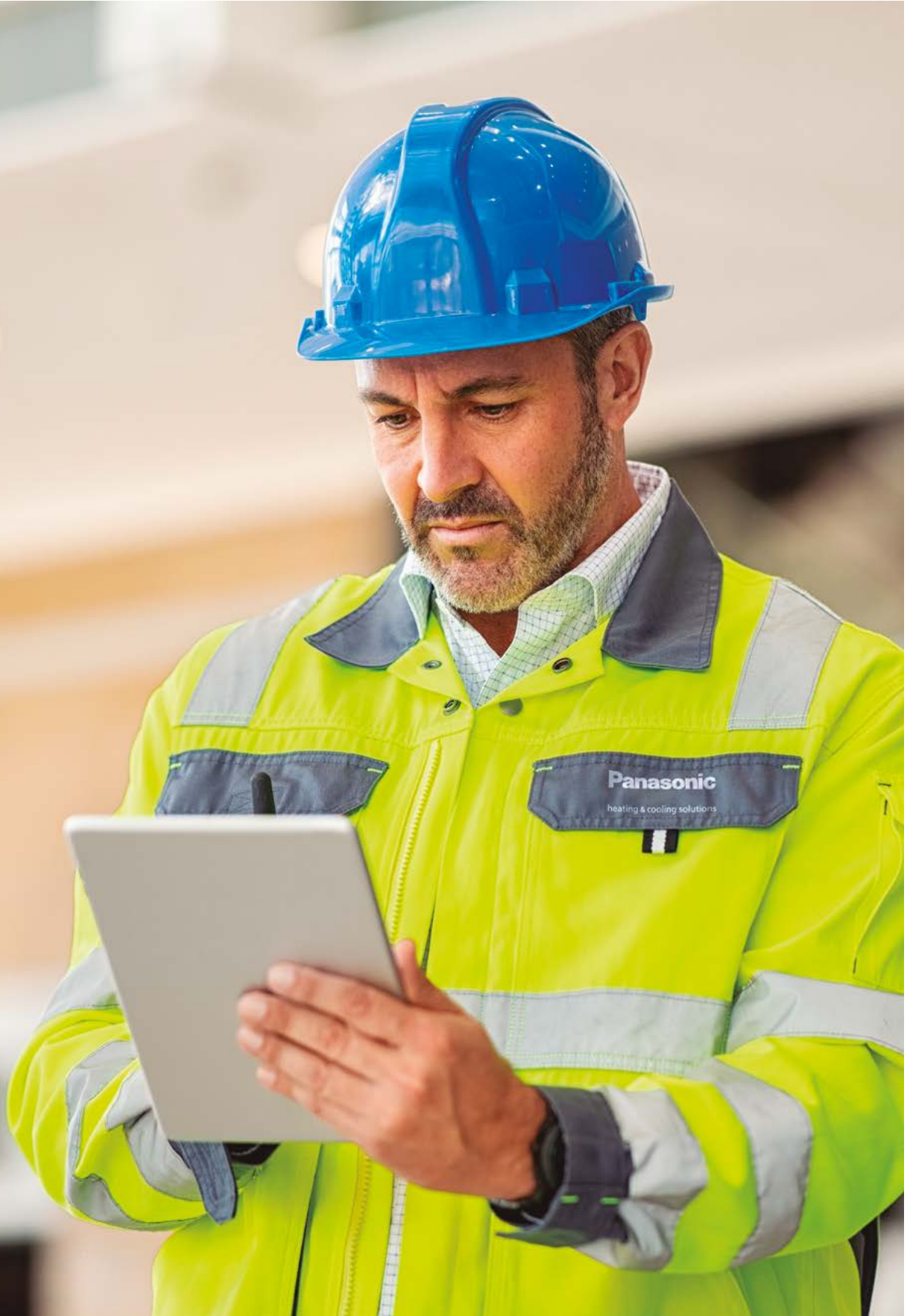

# A wide variety of HVAC system solutions

Panasonic solutions to suit a variety of commercial and industrial applications. Our systems provide the optimal performance in any climatic condition.

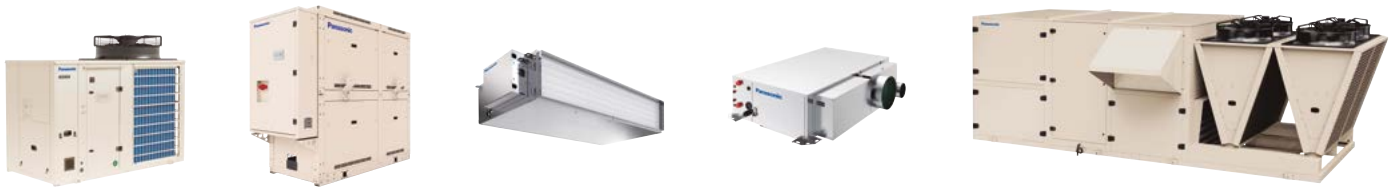

## 1 Air cooled chillers, heat pumps and condensing units

The air cooled chiller variant of the system is also a fundamental part of many industrial processes.

## 2 Water cooled chillers, heat pumps and condenserless units

This system is particularly well suited for applications such as office buildings, hotels, shopping centers and hospitals.

## 3 Fan coil units

Panasonic offers various fan coil units designed to provide the best performance and comfort in any condition during the year. Available as ducted, floor, ceiling or wall-mounted units that offer a comfortable environment for commercial applications.

## 4 Water source heat pumps

Water source heat pumps are ideal for best in class hotels, offices or shopping centers. This solution offers improved comfort by having several different indoor climates inside a building, while maintaining the energy through an internal closed water loop.

## 5 Rooftop

With rooftop units, you get a complete compact and mono-bloc solution to heat and cool large buildings such as shopping centers, industries or airports that need high capacities. It is an easy to install, space saving solution, directly on the roof or close to a building.



### AC SELECT.

**Use AC SELECT to choose and configure your hydronic solution.**

Panasonic online selection tool offers an easy and quick solution to specify all the hydronics ranges and rooftops at required conditions.



<https://acselect.panasonic.eu/>

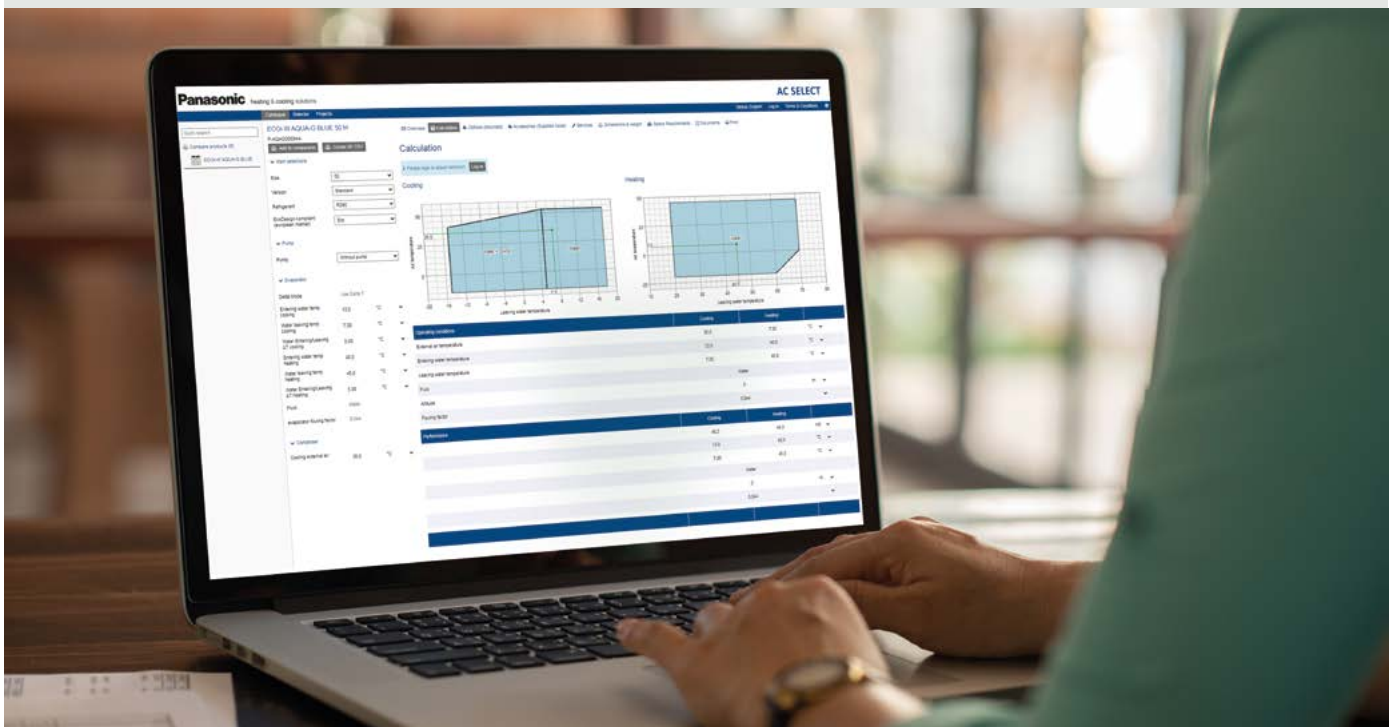

# ECOi-W AQUA-G BLUE. A revolutionary solution

## Reversible heat pumps with high leaving water temperature.

Introducing a revolutionary solution for sustainable cooling and heating needs, ECOi-W AQUA-G BLUE powered by R290, a natural refrigerant. It delivers both sustainability and efficiency in one innovative package.



**Natural refrigerant  
R290 with GWP 3.**



**Reliable  
quality.**



**Scroll  
compressors.**

**HIGH SEER**  
Max. 4,4<sup>1)</sup>

**HIGH SCOP**  
Max. 3,9<sup>2)</sup>

**High seasonal  
efficiency.**

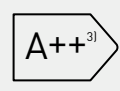

**High energy  
efficiency class.**

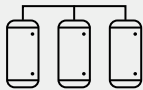

**DHW  
management.**



**Maximum 70 °C leaving  
water temperature.**



**Quiet  
operation.**



**Boost the capacity up  
to 640 kW.**

1) Size 50. According EN14825 and Following COMMISSION REGULATION (EU) 2016/2281.2) Size 70. According EN14825 and Following COMMISSION REGULATION (EU) No 813/2013. 3) Scale A+++ to D. According EN14825 and Following COMMISSION REGULATION (EU) No 813/2013.



**Air cooled heat pumps R290.**  
The future of efficient commercial air to water heat pumps.



**Care about the environment and get greater efficiency.**

ECOi-W AQUA-G BLUE is born from a perfect combination of new green technology and our existing ECOi-W product range already known for its performance and reliability. It operates with the natural R290 refrigerant that offers greater efficiency while having almost no impact on the environment with one of the lowest **GWP (Global Warming Potential): only 3!** Make the choice to reach incredible efficiencies, extend the operating limits, and contribute to environmental preservation.



50 kW



60 kW



70 - 80 kW

**Extended operating limits**

Operating range in cooling mode.

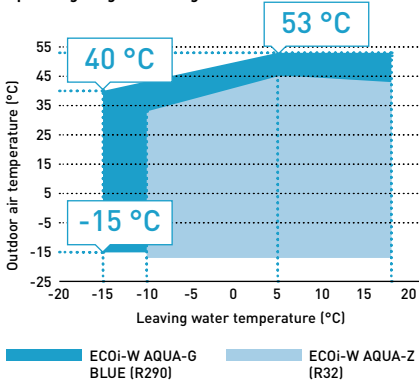

Operating range in heating mode.

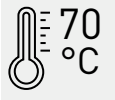
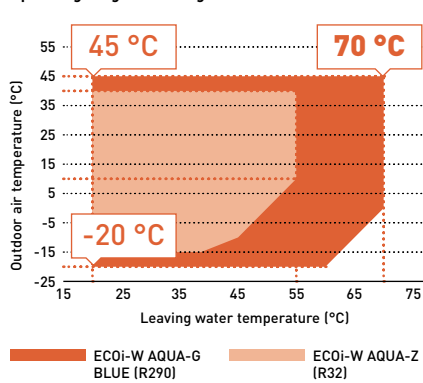

**Cooling mode.**

A water outlet temperature of -15 °C ensures optimal operation temperature for process equipment in factories.

**Heating mode.**

Ideal solution for Heating and Domestic Hot Water production. Reaching 70 °C from 0 °C outside air temperature.

**Quiet operation. Discover a unique feature of ECOi-W AQUA-G BLUE**

Sound power level (dB(A)).

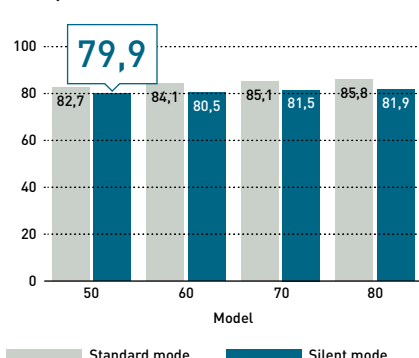

Sound pressure level (dB(A)).

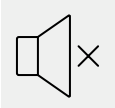
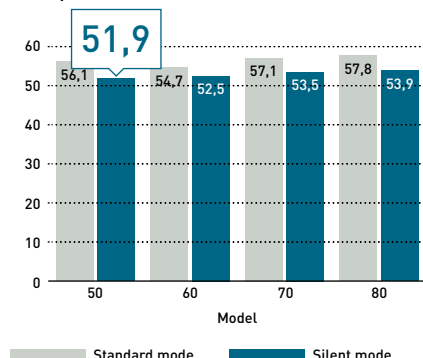





**Silent mode.**

Silent mode with an impressively low sound power level of only 79,9 dB(A), pressure level of only 51,9 dB(A). ECOi-W AQUA-G BLUE provides the perfect balance of efficiency and silent operation. Optional compressor jackets for size 50 and optional compressor box for sizes 60-70-80 are available to provide an additional level of noise reduction.

# Quick selection guide - Air cooled chillers

Page	Size	Cooling capacity (kW)	SEER	Sound power (dB(A))	Dimension LxHxW (mm)
P. 482	<b>ECOi-W AQUA C · R410A</b>				
	20	19,2	4,78	75	1000 x 1983 x 1000
	25	24,3	4,38	75	1000 x 1983 x 1000
	30	27,1	4,43	75	1000 x 1983 x 1000
	35	36,7	4,43	76	1000 x 1983 x 1000
P. 484	40	39,0	4,48	76	1000 x 1983 x 1000
	45	45,3	4,40	80	2180 x 1986 x 1160
	55	52,0	4,53	80	2180 x 1986 x 1160
	65	66,1	4,53	80	2180 x 1986 x 1160
	75	73,1	4,68	80	2180 x 1986 x 1160
	90	90,9	4,45	83	2180 x 2286 x 1160
	105	104,0	4,50	83	2180 x 2286 x 1160
	125	123,0	4,55	83	2180 x 2286 x 1160
	140	132,0	4,40	85	2856 x 2295 x 2210
	150	146,0	4,45	85	2856 x 2295 x 2210
P. 486	170	164,0	4,38	87	2856 x 2321 x 2210
	190	181,0	4,40	88	2856 x 2321 x 2210
	210	208,0	4,25	88	2856 x 2321 x 2210
	<b>ECOi-W AQUA-Z C · R32</b>				
	50	51,6	4,60	83	2180x x 1986 x 1160
	60	57,6	4,59	84	2180x x 1986 x 1160
	70	69,7	4,61	81	2180x x 1986 x 1160
75	78,2	4,72	81	2180x x 1986 x 1160	
P. 488	85	82,8	4,45	84	2180x x 2286 x 1160
	100	100,0	4,88	86	2180x x 2286 x 1160
	115	116,0	4,59	87	2180x x 2286 x 1160
	130	126,0	4,43	87	2180x x 2286 x 1160
	150	154,0	4,70	89	3789 x 2285 x 1151
	170	173,0	4,68	91	3789 x 2285 x 1151
	<b>NEW ECOi-W AQUA-Z DC C · R32</b>				
	150	151,0	4,93	89,6	3795 x 2240 x 1152
	170	170,0	4,90	90,4	3795 x 2240 x 1152
	P. 490	190	189,0	4,68	91,1
210		212,0	4,62	91,5	2676 x 2250 x 2211
230		229,0	4,48	92,0	2676 x 2250 x 2211
260		260,0	4,40	92,4	2676 x 2250 x 2211
290		307,0	4,63	93,3	3801 x 2250 x 2211
320		326,0	4,33	94,3	3801 x 2250 x 2211
350		346,0	4,43	95,2	3801 x 2250 x 2211
380	377,0	4,35	95,4	3801 x 2250 x 2211	

\* Dimensions without water tank.





Page	Size	Cooling capacity (kW)	SEER	Sound power (dB(A))	Dimension LxHxW (mm)
<b>P. 492</b> 	85	83,5	4,55	84	2555 x 2185 x 1095
	95	93,6	4,80	84	2555 x 2185 x 1095
	105	103,0	4,78	84	2555 x 2185 x 1095
	115	110,1	4,80	84	2555 x 2185 x 1095
	125	121,9	4,73	88	3155 x 2185 x 1095
	140	136,6	4,53	88	3155 x 2185 x 1095
<b>P. 500</b> 	230	231,0	4,25	92	3500 x 2500 x 2150
	260	263,0	4,25	93	3500 x 2500 x 2150
	280	284,0	4,23	93	3500 x 2500 x 2150
	300	310,0	4,18	94	4550 x 2500 x 2150
	330	331,0	4,20	95	4550 x 2500 x 2150
	360	362,0	4,10	95	4550 x 2500 x 2150
<b>P. 504</b> 	400	398,8	4,48	92	4580 x 2500 x 2175
	450	446,1	4,43	93	5620 x 2500 x 2175
	490	487,7	4,50	93	6680 x 2500 x 2175
	530	533,9	4,38	94	6680 x 2500 x 2175
	600	597,1	4,58	94	7760 x 2500 x 2175
	670	667,3	4,65	94	7760 x 2500 x 2175
<b>P. 508</b> 	750	748,3	4,48	95	8900 x 2500 x 2175
	800	797,9	4,50	95	8900 x 2500 x 2175
	380	365,7	4,53	97	4660 x 2510 x 2192
	440	443,0	4,66	98	5712 x 2510 x 2192
	510	500,2	4,65	100	5712 x 2510 x 2192
	590	565,8	4,80	100	6764 x 2510 x 2192
<b>P. 508</b> 	660	643,5	4,66	100	7816 x 2510 x 2192
	730	704,3	4,56	101	7816 x 2510 x 2192
	810	778,1	4,62	101	8868 x 2510 x 2192
	900	896,9	4,56	102	9920 x 2510 x 2192
	980	983,5	4,60	102	10972 x 2510 x 2192
	1060	1047,4	4,87	103	12024 x 2510 x 2192
	1160	1154,0	4,86	103	13076 x 2510 x 2192
	1260	1240,5	4,85	103	13076 x 2510 x 2192

\* Dimensions without water tank.

# Quick selection guide - Air cooled heat pumps

Page	Size	Cooling and heating capacity (kW)	SEER / SCOP	Sound power (dB(A))	Dimension LxHxW (mm)
P. 478	20	21,0	3,30 / 3,75	74	1477 x 1615 x 539
		20,4			
P. 478	30	28,0	3,98 / 3,68	75	1477 x 1615 x 539
		26,1			
<b>NEW ECOi-W AQUA-Z EVO H · R32</b>  <div style="text-align: center;"> <h2>Sizes from 20 to 50</h2> <h2>Coming soon</h2> <h2>Autumn 2024</h2> </div>					
P. 480	50	48,2	4,40 / 3,70	83	2215 x 1730 x 1032
		49,2			
		56,1			
		61,1			
P. 480	60	64,9	4,30 / 3,70	84	2180 x 2011 x 1160
		73,5			
		74,1			
		83,6			
P. 480	70	73,5	4,30 / 3,90	85	2180 x 2030 x 1160
		83,6			
		83,6			
		83,6			
P. 480	80	83,6	4,20 / 3,80	85	2180 x 2030 x 1160
		83,6			
		83,6			
		83,6			
P. 482	20	18,7	4,68 / 3,50	75	1000 x 1983 x 1000
		19,5			
	25	23,7	4,31 / 3,38	75	1000 x 1983 x 1000
		26,9			
	30	26,4	4,28 / 3,45	75	1000 x 1983 x 1000
		29,7			
	35	35,8	4,25 / 3,50	76	1000 x 1983 x 1000
		37,3			
	40	38,1	4,33 / 3,50	76	1000 x 1983 x 1000
		41,6			
45	44,3	4,20 / 3,38	80	2180 x 1986 x 1160	
	48,5				
55	50,9	4,41 / 3,38	80	2180 x 1986 x 1160	
	58,2				
65	64,1	4,51 / 3,55	80	2180 x 1986 x 1160	
	67,3				
75	71,0	4,63 / 3,53	80	2180 x 1986 x 1160	
	76,0				
90	88,7	4,40 / 3,40	83	2180 x 2286 x 1160	
	88,2				
105	101,0	4,44 / 3,43	83	2180 x 2286 x 1160	
	101,0				
125	119,0	4,49 / 3,43	83	2180 x 2286 x 1160	
	119,0				
140	128,0	4,39 / 3,30	85	2856 x 2295 x 2210	
	144,0				
150	142,0	4,36 / 3,33	85	2856 x 2295 x 2210	
	154,0				
170	164,0	4,31 / 3,30	87	2856 x 2321 x 2210	
	170,0				
190	178,0	4,23 / 3,28	88	2856 x 2321 x 2210	
	195,0				
210	208,0	4,28 / 3,23	88	2856 x 2321 x 2210	
	218,0				

\* Dimensions without water tank.

Page	Size	Cooling and heating capacity (kW)	SEER / SCOP	Sound power (dB(A))	Dimension LxHxW (mm)		
P. 488	 R32	50	51,1 / 51,7	4,46 / 3,63	83	2180 x 1986 x 1160	
		60	57,0 / 59,7	4,42 / 3,51	84	2180 x 1986 x 1160	
		70	69,0 / 71,8	4,51 / 3,49	81	2180 x 1986 x 1160	
		75	77,4 / 78,5	4,61 / 3,56	81	2180 x 1986 x 1160	
		85	82,0 / 86,5	4,33 / 3,76	84	2180 x 2286 x 1160	
		100	99,3 / 107,6	4,77 / 3,56	86	2180 x 2286 x 1160	
	 R32	115	115,0 / 122,3	4,44 / 3,77	87	2180 x 2286 x 1160	
		130	125,0 / 137,5	4,23 / 3,81	87	2180 x 2286 x 1160	
		150	152,0 / 159,1	4,59 / 3,78	89	3789 x 2285 x 1151	
	P. 490	 R32	150	150,0 / 154,0	4,75 / 3,83	89,6	3795 x 2240 x 1152
			170	167,0 / 178,0	4,71 / 3,90	90,4	3795 x 2240 x 1152
		 R32	190	184,0 / 190,0	4,45 / 3,46	91,1	2678 x 2250 x 2211
			210	204,0 / 201,0	4,39 / 3,44	91,5	2678 x 2250 x 2211
220**			208,0 / 219,0	5,03 / 3,86	91,3	2676 x 2300 x 2211	
230			224,0 / 241,0	4,34 / 3,64	92,0	2678 x 2250 x 2211	
260			251,0 / 256,9	4,21 / 3,52	92,4	2678 x 2250 x 2211	
270**			265,0 / 288,0	5,01 / 3,82	92,8	3801 x 2300 x 2211	
 R32		290	291,1 / 285,6	4,34 / 3,51	93,3	3801 x 2250 x 2211	
		300**	295,0 / 312,0	5,01 / 3,92	93,1	3801 x 2300 x 2211	
		320	307,7 / 301,3	4,33 / 3,50	94,3	3801 x 2250 x 2211	
		350	330,0 / 337,0	4,40 / 3,50	95,2	3801 x 2250 x 2211	
		380	364,0 / 384,0	4,34 / 3,66	95,4	3801 x 2250 x 2211	

\* Dimensions without water tank. \*\* Only EC fans version.

New ECOi-W solutions coming with R32 refrigerant.

NEW ECOi-W AQUA-Z EVO H · R32

Low GWP Inverter solution between 20 and 50 kW.

- Inverter pump and single Inverter compressor
- EC fans
- Compact unit: 1,7 m maximum height
- External water tank designed to direct easy fitting to the unit



Scroll Inverter compressor.



NEW ECOi-W AQUA-Z DC C/H · R32

Double circuit solution with R32 refrigerant between 150 and 380 kW.



- 4 scroll compressors in 2 refrigerant circuits
- AC/EC fans
- Acoustic configurations: standard or super low noise
- Internal water tank with no impact on the unit footprint



Super quiet.



# Quick selection guide - Air cooled heat pumps

Page	Size	Cooling and heating capacity (kW)	SEER / SCOP	Sound power (dB(A))	Dimension LxHxW (mm)
P. 492 	85	81,0 91,8	4,25 / 3,61	84	2555 x 2185 x 1095
	95	89,9 102,8	4,68 / 3,64	84	2555 x 2185 x 1095
	105	98,9 110,0	4,63 / 3,78	84	2555 x 2185 x 1095
	115	106,9 119,0	4,17 / 3,77	84	2555 x 2185 x 1095
	125	115,8 134,0	4,33 / 3,47	88	3155 x 2185 x 1095
	140	129,2 146,9	4,28 / 3,54	88	3155 x 2185 x 1095
	P. 496 	704	173,2 200,1	3,63 / 3,41	93
804		197,1 223,2	3,55 / 3,42	93	4300 x 2300 x 1100
904		226,4 254,7	3,35 / 3,28	94	4300 x 2300 x 1100
1004		246,3 270,8	3,50 / 3,39	94	4300 x 2300 x 1100
1104		273,1 302,1	3,53 / 3,30	95	4300 x 2300 x 1100
1204		299,9 337,4	3,43 / 3,19	95	4300 x 2300 x 1100
P. 500 		230	213,6 229,0	4,13 / 3,46	92
	260	243,7 262,3	4,05 / 3,48	93	3500 x 2500 x 2150
	280	261,1 279,6	4,10 / 3,44	93	3500 x 2500 x 2150
	300	287,8 305,6	3,83 / 3,51	94	4550 x 2500 x 2150
	330	307,4 327,2	3,80 / 3,44	95	4550 x 2500 x 2150
	360	340,5 361,4	3,93 / 3,48	95	4550 x 2500 x 2150
	400	373,5 404,0	4,65 / 3,62	92	5620 x 2500 x 2175
	450	419,2 450,9	4,53 / 3,62	93	5620 x 2500 x 2175
	490	454,5 492,7	4,70 / 3,53	93	6680 x 2500 x 2175
	530	489,7 532,1	4,55 / 3,53	94	6680 x 2500 x 2175
	580	535,7 585,8	4,33 / —	94	7760 x 2500 x 2175
	620	581,5 627,7	4,35 / —	95	8800 x 2500 x 2175
	670	625,4 677,8	4,30 / —	95	8800 x 2500 x 2175
	750	701,4 758,3	4,30 / —	95	9950 x 2500 x 2175
	800	748,1 807,3	4,35 / —	95	9950 x 2500 x 2175

\* Dimensions without water tank.

# Quick selection guide - Air cooled condensing units

Page	Size	Cooling capacity (kW)	EER	Sound power (dB(A))	Dimension LxHxW (mm)
P. 482	<b>ECOi-W AQUA E · R410A</b>				
	25	32,4	3,24	75	1000 x 1983 x 1000
	30	33,7	3,15	75	1000 x 1983 x 1000
	35	43,1	2,90	76	1000 x 1983 x 1000
	40	44,8	2,99	76	1000 x 1983 x 1000
P. 484	<b>ECOi-W AQUA E · R410A</b>				
	45	57,4	2,94	80	2180 x 1986 x 1160
	55	64,5	2,89	80	2180 x 1986 x 1160
	65	72,4	2,97	80	2180 x 1986 x 1160
	75	79,3	2,91	80	2180 x 1986 x 1160
	90	104,0	2,65	83	2180 x 2286 x 1160
	105	120,0	2,79	83	2180 x 2286 x 1160
P. 492	<b>ECOi-W Aqv E · R410A</b>				
	125	136,0	2,66	83	2180 x 2286 x 1160
	85	92,1	3,36	84	2555 x 2185 x 1095
	95	103,2	3,29	84	2555 x 2185 x 1095
	105	113,2	3,32	84	2555 x 2185 x 1095
	115	121,8	3,30	84	2555 x 2185 x 1095
	125	134,7	3,23	88	3155 x 2185 x 1095
P. 496	<b>ECOi-W VL E · R410A</b>				
	140	151,0	3,23	88	3155 x 2185 x 1095
	704	199,0	2,90	93	4300 x 2300 x 1100
	804	224,0	3,00	93	4300 x 2300 x 1100
	904	258,0	2,98	94	4300 x 2300 x 1100
	1004	283,0	3,12	94	4300 x 2300 x 1100
	1104	315,0	2,98	95	4300 x 2300 x 1100
P. 500	<b>ECOi-W AQUA EVO E · R410A</b>				
	1204	347,0	2,90	95	4300 x 2300 x 1100
	230	250,3	3,36	92	3500 x 2500 x 2150
	260	288,4	3,42	93	3500 x 2500 x 2150
	280	312,7	3,42	93	3500 x 2500 x 2150
	300	337,2	3,39	94	4550 x 2500 x 2150
	330	361,2	3,45	95	4550 x 2500 x 2150
	360	394,5	3,37	95	4550 x 2500 x 2150

\* Dimensions without water tank.



# ECOi-W AQUA EVO H · R410A

Air cooled heat pumps Inverter.

Cooling capacity: 20,0 to 35,9 kW.

Heating capacity: 20,4 to 34,0 kW.



## The range at a glance

- 1 version: H (heat pump)
- 2 sizes

## Advantages

- Wide load variation capability:
  - Cooling operation down to 30% and up to 140% of nominal capacity
  - Heating operation down to 40% and up to 130% of nominal capacity
- Unit optimization in heating mode for both fan coil and floor applications
- Wide operating limits in heating mode
- Domestic Hot Water management
- Inverter compressor
- New fan motors (ErP compliant) with integrated grill and fan speed control as standard

## Equipment

- Inverter driven compressor
- Plate evaporator (AISI 316)
- A single Inverter driven 3-phase scroll compressor equipped with variable frequency brushless motor (20-120 Hz)
- 1 refrigerant circuit
- Bi-flow electronic expansion valve
- Multistage centrifugal pump as standard
- Bluefin coil
- Operating low water content in the plant
- Automatic circuit breaker
- Coil grilles
- Fan speed control
- Power factor corrector capacitors
- Phase sequence control
- Soft starter
- Water differential pressure switch
- Water filter
- DHW function available on the controller with DHW probe and 3 way valve available as options

## Operating limits

To be confirmed with AC SELECT:

<https://acselect.panasonic.eu/>

### Ambient temperature.

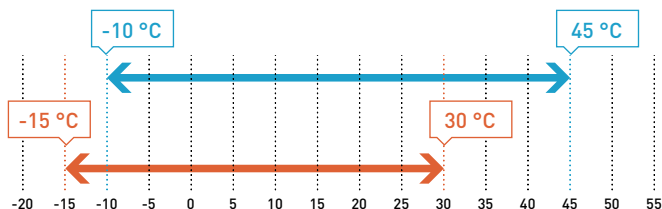

### Leaving water temperature.

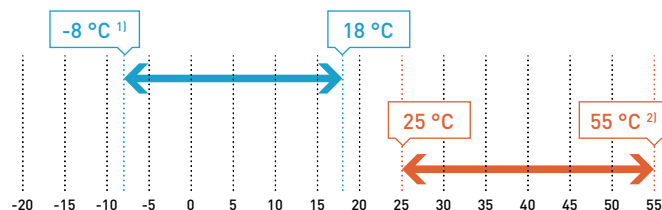

Cooling: outside air temperature [°C (DB)]. Heating: outside air temperature [°C (WB)].

1) Below 5 °C, glycol is required. For operation below 0 °C contact sales office.

2) Maximum leaving water temperature 55 °C [minimum outdoor air temperature -10 °C size 20, -15 °C size 30] to be confirmed with AC SELECT.

Chillers suitable for operation without buffer tank for water content greater than 2,5 liters of water per kW of output.

## AC SELECT.

Smart and user-friendly the new air conditioning selection program: <https://acselect.panasonic.eu/>





## Technical performance

Size			20	30
ECOi-W AQUA EVO H			P-AQAVE0020HA	P-AQAVE0030HA
Power supply	Voltage	V	400	400
	Phase		Three phase	Three phase
	Frequency	Hz	50	50
Cooling capacity <sup>1)</sup>	Nominal (Min - Max)	kW	20,0 (9,33 - 28,0)	29,0 (13,9 - 35,9)
Input power <sup>1)</sup>	Nominal (Min - Max)	kW	4,15 (2,38 - 6,61)	7,24 (3,51 - 13,0)
EER <sup>1)</sup>	Nominal (Min - Max)		4,82 (3,92 - 4,24)	4,01 (3,96 - 2,76)
Cooling capacity <sup>2)</sup>	Nominal (Min - Max)	kW	21,0 (6,60 - 25,2)	28,0 (9,43 - 31,1)
Input power <sup>2)</sup>	Nominal (Min - Max)	kW	6,95 (2,52 - 10,3)	10,9 (3,14 - 12,4)
EER <sup>2)</sup>	Nominal (Min - Max)		3,02 (2,62 - 2,45)	2,57 (3,00 - 2,51)
EER 75%			3,83	3,65
EER 50%			4,53	4,48
EER 25%			3,80	4,79
<b>SEER <sup>3)</sup></b>			<b>3,30</b>	<b>3,98</b>
$\eta_{s,c}$ <sup>3)</sup>			<b>129</b>	<b>156</b>
Nominal water flow (in the evaporator)		m <sup>3</sup> /h	3,64	5,92
Heating capacity <sup>4)</sup>	Nominal (Min - Max)	kW	20,4 (9,94 - 29,4)	26,1 (11,5 - 34,0)
Input power <sup>4)</sup>	Nominal (Min - Max)	kW	5,02 (2,98 - 8,37)	6,45 (3,01 - 9,80)
COP <sup>4)</sup>	Nominal (Min - Max)		4,06 (3,34 - 3,51)	4,05 (3,82 - 3,47)
Heating capacity <sup>5)</sup>	Nominal (Min - Max)	kW	20,4 (8,90 - 27,4)	26,1 (10,2 - 33,9)
Input power <sup>5)</sup>	Nominal (Min - Max)	kW	6,44 (3,34 - 9,64)	8,42 (3,97 - 11,6)
COP <sup>5)</sup>	Nominal (Min - Max)		3,17 (2,66 - 2,84)	3,10 (2,57 - 2,91)
<b>SCOP <sup>6)7)</sup></b>			<b>3,75</b>	<b>3,68</b>
<b>Energy efficiency class <sup>6)7)</sup></b>		<b>A+++ to D</b>	<b>A+</b>	<b>A+</b>
$\eta_{s,h}$ <sup>6)7)</sup>			<b>147</b>	<b>144</b>
<b>SCOP <sup>6)8)</sup></b>			<b>3,00</b>	<b>2,95</b>
<b>Energy efficiency class <sup>6)8)</sup></b>		<b>A+++ to D</b>	<b>A+</b>	<b>A+</b>
$\eta_{s,h}$ <sup>6)8)</sup>			<b>117</b>	<b>115</b>
Nominal water flow (in the evaporator)		m <sup>3</sup> /h	3,64	5,92
Sound power <sup>9)</sup>		dB(A)	74	75
Sound pressure at 10 m <sup>10)</sup>		dB(A)	43	44

## Physical features

ECOi-W AQUA EVO H			20	30
Dimension	HxWxL	mm	1615 x 539 x 1477	1615 x 539 x 1477
Operating weight		kg	260	275
<b>Water connections</b>				
Type of water connections (evaporator)			Male gas threaded	Male gas threaded
Water inlet/outlet diameter		Inch	1 ¼	1 ¼

1) According EN14511-2013: chilled water inlet/outlet temperature: 23/18 °C, outdoor ambient temperature 35 °C. 2) According EN14511-2013: chilled water inlet/outlet temperature: 12/7 °C, outdoor ambient temperature 35 °C DB. 3) According to EN14825 standard. 4) According EN14511-2013: warm water inlet/outlet temperature: 30/35 °C, outdoor ambient temperature 7 °C DB/6 °C WB. 5) According EN14511-2013: warm water inlet/outlet temperature: 40/45 °C, outdoor ambient temperature 7 °C DB/6 °C WB. 6) ErP compliant: following COMMISSION REGULATION (EU) No 813/2013. 7) According to EN14825 standard - low temperature application (35 °C). 8) According to EN14825 standard - medium temperature application (55 °C). 9) Sound levels are at fully loaded conditions. Sound power values refers to ISO 3744 standard. 10) Sound pressures refer to ISO 3744 standard, parallelepiped shape.

### Accessories and options

Buffer tank placed under unit  
Chassis acoustic insulation  
Coils treatments

### Accessories and options

In/out valve kit  
Remote ON / OFF  
Water flow switch





# ECOi-W AQUA-G BLUE 50-80 H - R290

Air cooled heat pumps.

Cooling capacity: 48,2 to 74,1 kW.

Heating capacity: 49,2 to 83,6 kW.



## The range at a glance

- 1 version: H (heat pump)
- 4 sizes
- 2 acoustic options: STD (standard) and S (super low noise)

## Advantages

- A super eco-friendly unit - employs natural refrigerant R290 with GWP 3
- Very high performance and improved energy efficiencies
- Smart energy consumption
- Expanded operating limit
- Domestic Hot Water management
- Compact chassis
- Very quiet operation
- Cascade controller available for multi-system operation
- SG Ready
- Very low refrigerant charge
- Reliable safety measurements

## Operating limits

To be confirmed with AC SELECT:

<https://acselect.panasonic.eu/>

Ambient temperature.

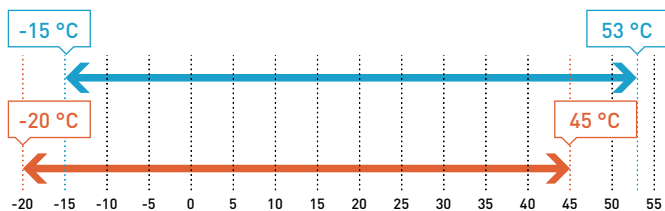

Leaving water temperature.

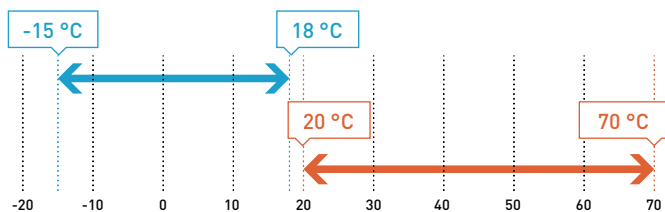

## Equipment

- Fan speed control. All units are equipped with EC fan technology
- Variable speed pump - option. A variable speed pump can be added to the unit for even greater energy savings
- Controller. This new high standard control system provides excellent pressure control, as well as global and optimised unit management
- Removable panels. Great accessibility to internal components for service operations
- Condenser. Highly optimised heat exchanger design enables a refrigerant charge reduction. Lower than 5,0 kg of R290 for the sizes 50 and 60
- Sealed electrical box. Non-flammable control box. The core parts are protected with a sealed metallic box
- Electronic expansion valve. This reliable and high-performant valve minimises overheating of the evaporator. It is directly managed by the control system
- Modbus RTU, Modbus TCP/IP, BACnet MSTP or BACnet IP
- Leak detector and safety ventilation fans to detect R290 leakages and exhaust refrigerant to atmosphere in the event of a leak
- DHW function available on the controller with DHW probe and 3 way valve available as options

## AC SELECT.

Smart and user-friendly the new air conditioning selection program: <https://acselect.panasonic.eu/>





## Technical performance

Size			50	60	70	80
Power supply	Voltage	V	400	400	400	400
	Phase		Three phase	Three phase	Three phase	Three phase
	Frequency	Hz	50	50	50	50
<b>ECOi-W AQUA-G BLUE 50-80 H EC fan - heat pump</b>			<b>P-AQAG0050HA</b>	<b>P-AQAG0060HA</b>	<b>P-AQAG0070HA</b>	<b>P-AQAG0080HA</b>
Cooling capacity <sup>1)</sup>	kW		48,2	56,1	64,9	74,1
Input power <sup>1)</sup>	kW		15,0	19,0	21,6	25,0
EER <sup>1)</sup>			3,20	3,00	3,00	3,00
<b>SEER <sup>2)</sup></b>			<b>4,37</b>	<b>4,30</b>	<b>4,31</b>	<b>4,21</b>
$\eta_{s,c}$ <sup>2)</sup>	%		<b>171,9</b>	<b>168,9</b>	<b>169,4</b>	<b>165,4</b>
Heating capacity <sup>3)</sup>	kW		49,2	61,1	73,5	83,6
Input power <sup>3)</sup>	kW		15,6	18,6	21,7	24,9
COP <sup>3)</sup>			3,2	3,3	3,4	3,4
<b>SCOP <sup>4)</sup></b>			<b>3,67</b>	<b>3,75</b>	<b>3,87</b>	<b>3,84</b>
$\eta_{s,h}$ <sup>4)</sup>			<b>143,7</b>	<b>146,8</b>	<b>151,8</b>	<b>150,5</b>
<b>Energy efficiency class (SCOP) <sup>4)</sup></b>		<b>A+++ to D</b>	<b>A+</b>	<b>A+</b>	<b>A++</b>	<b>A++</b>
<b>SCOP<sub>MT</sub> <sup>4)</sup></b>			<b>3,11</b>	<b>3,14</b>	<b>3,26</b>	<b>3,22</b>
$\eta_{s,MT}$ <sup>4)</sup>			<b>121,4</b>	<b>122,7</b>	<b>127,3</b>	<b>126,0</b>
<b>Energy efficiency class (SCOP<sub>MT</sub>) <sup>4)</sup></b>		<b>A+++ to D</b>	<b>A+</b>	<b>A+</b>	<b>A++</b>	<b>A++</b>
Sound power (STD / S)	dB(A)		82,7 / 79,9	84,1 / 80,5	85,1 / 81,5	85,8 / 81,9
Sound pressure at 10 m (STD / S) <sup>5)</sup>	dB(A)		56,1 / 51,9	54,7 / 52,5	57,1 / 53,5	57,8 / 53,9

## Physical features

<b>ECOi-W AQUA-G BLUE 50-80 H EC fan - heat pump</b>			50	60	70	80
Dimension	Height	mm	1730	2011	2030	2030
	Length w/o / w water tank	mm	2215 / 2215 <sup>4)</sup>	2180 / 2680	2180 / 2680	2180 / 2680
	Width	mm	1032	1160	1160	1160
Operating weight	kg		538	603	628	669
<b>Refrigerant and compressors</b>						
Number of refrigerant circuits			1	1	1	1
Refrigerant (R290)	kg		4,50	4,80	5,30	6,80
GWP	CO <sub>2</sub> eq.		3 (100 years)	3 (100 years)	3 (100 years)	3 (100 years)
Compressors	Number / type		2 / Scroll	2 / Scroll	2 / Scroll	2 / Scroll
Capacity steps	%		50 / 100	40 / 60 / 100	40 / 60 / 100	50 / 100
<b>Water connections</b>						
Type of water connections			Male gas threaded	Male gas threaded	Male gas threaded	Male gas threaded
Water inlet/outlet diameter	Inch		1 ¼	2	2	2 ½
<b>Buffer tank (option)</b>						
Volume	l		200	300	300	300

1) According EN14511-2013: chilled water inlet/outlet temperature: 12/7 °C, outdoor ambient temperature 35 °C DB. 2) According EN14825 and following COMMISSION REGULATION (EU) 2016/2281. 3) According EN14511-2013: warm water inlet/outlet temperature: 40/45 °C, outdoor ambient temperature 7 °C DB/6 °C WB. 4) According to EN14825 and following COMMISSION REGULATION (EU) No 813/2013. 5) Sound pressures refer to ISO 3744 standard, parallelepiped shape. 6) Tank is external to the unit chassis. Its width must be added.

\* w/o: without, w: with.

### Accessories and options

Anti-vibration rubber mount / spring dampers  
 Cascade controller  
 Refrigerant gauges HP/LP  
 Shut off valves  
 Sofstarter  
 Energy meter for input power

### Accessories and options

Electrical heater for the water tank  
 Variable or fixed speed pumps  
 Water tank 200 l (size 50)  
 Water tank 300 l (sizes 60-70-80)  
 3 Way valve and probe for Domestic Hot Water management





# ECOi-W AQUA 20-40 C/H/E - R410A

Air cooled chillers, heat pumps and condensing units.

Cooling capacity: 19,3 to 40,9 kW.

Heating capacity: 19,5 to 41,6 kW.



## The range at a glance

- 3 versions: C (chiller), H (heat pump) and E (condensing unit)
- SEER up to 4,59
- SCOP up to 3,40
- 5 sizes (4 sizes for E type)
- 2 configurations: STD (standard) and HPF (high pressure fan)

## Advantages

- Very high performance
- Low noise units
- Wide operating limits
- Easy maintenance: great accessibility to the internal components
- Low footprint
- Smart defrost technology: 1 defrost every 130 minutes for a constant LWT even at very low OAT (H type)
- Optimised for partial load operation
- 100% factory tested

## Operating limits

To be confirmed with AC SELECT:

<https://acselect.panasonic.eu/>

Ambient temperature (chiller, heat pump and condensing unit).

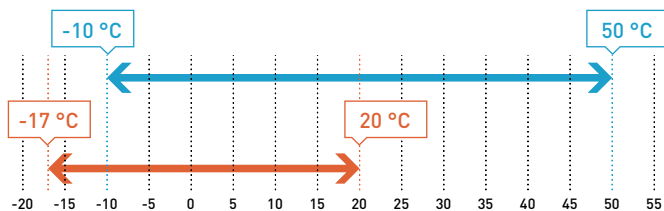

Leaving water temperature (chiller and heat pump).

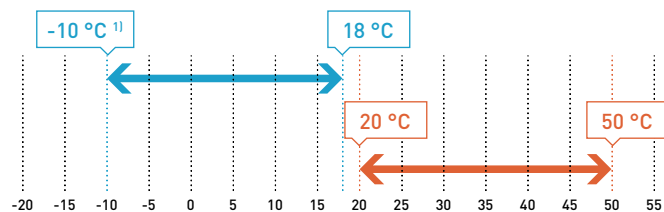

1) With glycol, 5 °C without glycol.

## Equipment

- 1 refrigerant circuit with tandem scroll compressors for a higher efficiency at partial load
- Stainless steel plate heat exchanger insulated with closed cell synthetic foam (C/H types)
- Finned coil condenser constructed with seamless copper tubes mechanically expanded into aluminium fins - Bluefin treatment for H type
- Hydraulic circuit without pump (C type) / without or with a fixed speed pump (H type)
- Super low noise units: acoustic box around the compressors
- Complete integrated control system with an external control panel that displays operating parameters and alarms
- Modbus RTU communication protocol as standard
- Night mode for energy savings and reduced sound levels
- Double water set point (H type)
- Water compensation curve control (C/H types)
- Return and leaving water temperature control (C/H types)
- Water filter and water flow switch (C/H types)
- Phase sequence monitor
- Suction and liquid line shut-off valves + a suction receiver (E type)

## AC SELECT.

Smart and user-friendly the new air conditioning selection program: <https://acselect.panasonic.eu/>





## Technical performance

Power supply	Voltage	V	400	400	400	400	400
	Phase		Three phase	Three phase	Three phase	Three phase	Three phase
	Frequency	Hz	50	50	50	50	50
<b>Size</b>			<b>20</b>	<b>25</b>	<b>30</b>	<b>35</b>	<b>40</b>
<b>ECOi-W AQUA 20-40 C - chiller</b>			<b>P-AQAE0020CA</b>	<b>P-AQAE0025CA</b>	<b>P-AQAE0030CA</b>	<b>P-AQAE0035CA</b>	<b>P-AQAE0040CA</b>
Cooling capacity <sup>1)</sup>	kW		19,2	24,3	27,1	36,7	39,0
Input power <sup>1)</sup>	kW		5,9	7,7	9,3	12,2	13,0
EER <sup>1)</sup>			3,25	3,17	2,9	3,01	3,0
<b>SEER <sup>2)3)</sup></b>			<b>4,78</b>	<b>4,38</b>	<b>4,43</b>	<b>4,43</b>	<b>4,48</b>
$\eta_{s,c}$ <sup>2)3)</sup>			<b>188</b>	<b>172</b>	<b>174</b>	<b>174</b>	<b>176</b>
Nominal water flow (in the evaporator)	m <sup>3</sup> /h		3,3	4,2	4,7	6,3	6,7
Sound power (STD fan)	dB(A)		75	76	76	77	77
Sound pressure at 10 m (STD fan) <sup>4)</sup>	dB(A)		42,8	43,8	43,8	44,8	44,8
<b>ECOi-W AQUA 20-40 H - heat pump</b>			<b>P-AQAE0020HA</b>	<b>P-AQAE0025HA</b>	<b>P-AQAE0030HA</b>	<b>P-AQAE0035HA</b>	<b>P-AQAE0040HA</b>
Cooling capacity <sup>1)</sup>	kW		18,7	23,7	26,4	35,8	38,1
Input power <sup>1)</sup>	kW		5,9	7,7	9,4	12,3	13,1
EER <sup>1)</sup>			3,15	3,07	2,81	2,92	2,92
<b>SEER <sup>2)</sup></b>			<b>4,68</b>	<b>4,31</b>	<b>4,28</b>	<b>4,25</b>	<b>4,33</b>
$\eta_{s,c}$ <sup>2)</sup>			<b>184</b>	<b>169</b>	<b>168</b>	<b>167</b>	<b>170</b>
Nominal water flow (in the evaporator)	m <sup>3</sup> /h		3,3	4,3	4,6	6,2	6,4
Heating capacity <sup>5)</sup>	kW		19,5	26,9	29,7	37,3	41,6
Input power <sup>5)</sup>	kW		6,1	9,3	9,9	13,2	13,5
COP <sup>5)</sup>			3,19	2,90	2,99	2,82	3,08
COP <sup>6)</sup>			4,17	4,10	4,10	4,11	3,86
<b>SCOP <sup>2)7)</sup></b>			<b>3,50</b>	<b>3,38</b>	<b>3,45</b>	<b>3,50</b>	<b>3,50</b>
<b>Energy efficiency class <sup>2)7)</sup></b>		<b>A+++ to D</b>	<b>A+</b>	<b>A+</b>	<b>A+</b>	<b>A+</b>	<b>A+</b>
$\eta_{s,h}$ <sup>2)7)</sup>			<b>137</b>	<b>132</b>	<b>135</b>	<b>137</b>	<b>137</b>
Nominal water flow (in the evaporator)	m <sup>3</sup> /h		3,4	4,7	5,2	6,5	7,2
Sound power (STD fan)	dB(A)		75	76	76	77	77
Sound pressure at 10 m (STD fan) <sup>4)</sup>	dB(A)		42,8	43,8	43,8	44,8	44,8
<b>ECOi-W AQUA 25-40 E - condensing unit</b>			<b>—</b>	<b>P-AQAE0025EA</b>	<b>P-AQAE0030EA</b>	<b>P-AQAE0035EA</b>	<b>P-AQAE0040EA</b>
Cooling capacity <sup>8)</sup>	kW		—	32,4	33,7	43,1	44,8
Input power <sup>8)</sup>	kW		—	10,0	10,7	14,9	15,0
EER <sup>8)</sup>			—	3,24	3,15	2,90	2,99
Sound power	dB(A)		—	75	75	76	76

## Physical features

<b>ECOi-W AQUA 20-40 C/H - chiller / heat pump</b>			<b>20</b>	<b>25</b>	<b>30</b>	<b>35</b>	<b>40</b>
Dimension	Height (STD / HPF)	mm	1983 / 2025	1983 / 2025	1983 / 2025	1983 / 2025	1983 / 2025
	Width w/o / w water tank	mm	1000 / 1507	1000 / 1507	1000 / 1507	1000 / 1507	1000 / 1507
	Length	mm	1000	1000	1000	1000	1000
Operating weight without / with water tank - 1 pump	kg		285 / 450	295 / 460	325 / 490	335 / 500	335 / 500
<b>Water connections</b>							
Type of water connections (evaporator)			Male gas threaded BSPP ISO 228	Male gas threaded BSPP ISO 228	Male gas threaded BSPP ISO 228	Male gas threaded BSPP ISO 228	Male gas threaded BSPP ISO 228
Water inlet/outlet diameter	Inch		1 1/2	1 1/2	1 1/2	1 1/2	1 1/2
<b>ECOi-W AQUA 25-40 E - condensing unit</b>			<b>—</b>	<b>25</b>	<b>30</b>	<b>35</b>	<b>40</b>
Dimension	H x W x L	mm	—	1983 x 1000 x 1000	1983 x 1000 x 1000	1983 x 1000 x 1000	1983 x 1000 x 1000
Operating weight	kg		—	260	270	280	280
<b>Refrigerant connections</b>							
Liquid line	Inch		—	5/8	5/8	5/8	5/8
Suction line	Inch		—	1 1/8	1 1/8	1 1/8	1 1/8

1) According EN14511-2013: chilled water inlet/outlet temperature: 12/7 °C, outdoor ambient temperature 35 °C DB. 2) According EN14825. 3) ErP compliant: following COMMISSION REGULATION (EU) 2016/2281. 4) Sound pressures refer to ISO 3744 standard, parallelepiped shape. 5) According EN14511-2013: warm water inlet/outlet temperature: 40/45 °C, outdoor ambient temperature 7 °C DB/6 °C WB. 6) According EN14511-2013: warm water inlet/outlet temperature: 30/35 °C, outdoor ambient temperature 7 °C DB/6 °C WB. 7) ErP compliant: following COMMISSION REGULATION (EU) No 813/2013. 8) Data refers to 7 °C leaving chilled water temperature and 35 °C condenser air temperature, according EN14511-2013 standard.

\* w/o: without, w: with.

### Accessories and options

Anti-vibration rubber mount / spring dampers
BACnet IP or BACnet MSTP
Fan speed control
Finned coil blygold treatment (upon request) or epoxy
High pressure fan (HPF)
Modbus TCP/IP

### Accessories and options

Outdoor coil protection grid
Nordic pack (H type only)
Remote control
Shut off valves
Soft starter
SRC - mini BMS controller

### Accessories and options

Variable or fixed* speed pumps
Water pressure switch
Water tank 100 l
Without neutral (upon request)

\* Not available with ECOi-W AQUA C and ECOi-W AQUA H 20-30 due to Ecodesign compliance.





# ECOi-W AQUA 45-125 C/H/E - R410A

Air cooled chillers, heat pumps and condensing units.

Cooling capacity: 46,8 to 129,8 kW.

Heating capacity: 48,5 to 119,1 kW.



## The range at a glance

- 3 versions: C (chiller), H (heat pump) and E (condensing unit)
- 7 sizes
- SEER up to 4,41
- SCOP up to 3,43
- 2 configurations: STD (standard) and HPF (high pressure fan)
- 2 acoustic options: STD (standard) and S (super low noise)

## Advantages

- Very high performance
- Low noise units
- Wide operating limits
- Easy maintenance: great accessibility to the internal components
- Low footprint
- Smart defrost technology: 1 defrost every 130 minutes for a constant LWT even at very low OAT (H type)
- Optimised for partial load operation
- 100% factory tested

## Operating limits

To be confirmed with AC SELECT:

<https://acselect.panasonic.eu/>

Ambient temperature (chiller, heat pump and condensing unit).

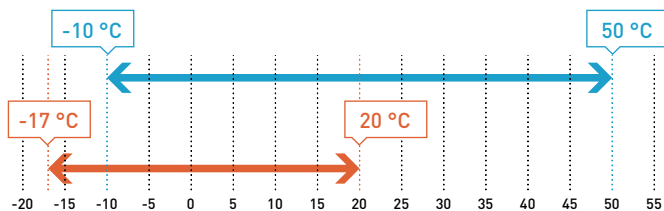

Leaving water temperature (chiller and heat pump).

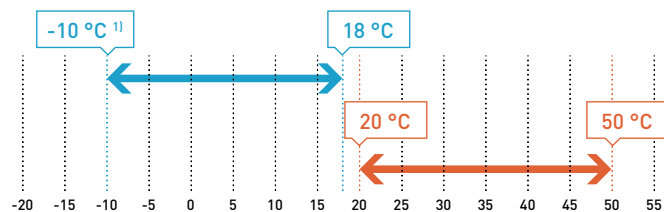

1) With glycol, 5 °C without glycol.

## Equipment

- 1 refrigerant circuit with tandem scroll compressors for a higher efficiency at partial load
- Stainless steel plate heat exchanger insulated with closed cell synthetic foam (C/H types)
- Finned coil condenser constructed with seamless copper tubes mechanically expanded into aluminium fins - Bluefin treatment for H type
- Hydraulic circuit without pump
- Complete integrated control system with an external control panel that displays the operating parameters and alarms
- Modbus RTU communication protocol as standard
- Night mode for energy savings and reduced sound levels
- Double water set point (H type)
- Water compensation curve control (C/H types)
- Return and leaving water temperature control (C/H types)
- Water filter and water flow switch (C/H types)
- Phase sequence monitor
- Suction and liquid line shut-off valves + a suction receiver (E type)

## AC SELECT.

Smart and user-friendly the new air conditioning selection program: <https://acselect.panasonic.eu/>





Technical performance

	Voltage	V	400	400	400	400	400	400	400
Power supply	Phase		Three phase	Three phase	Three phase	Three phase	Three phase	Three phase	Three phase
	Frequency	Hz	50	50	50	50	50	50	50
	<b>Size</b>		<b>45</b>	<b>55</b>	<b>65</b>	<b>75</b>	<b>90</b>	<b>105</b>	<b>125</b>
<b>ECOi-W AQUA 45-125 C - chiller</b>			<b>P-AQAE0045CA</b>	<b>P-AQAE0055CA</b>	<b>P-AQAE0065CA</b>	<b>P-AQAE0075CA</b>	<b>P-AQAE0090CA</b>	<b>P-AQAE0105CA</b>	<b>P-AQAE0125CA</b>
Cooling capacity <sup>1)</sup>	kW		45,3	52,0	66,1	73,1	90,9	104,0	123,0
Input power <sup>1)</sup>	kW		15,4	17,6	21,7	24,0	30,7	34,9	40,6
EER <sup>1)</sup>			2,95	2,96	3,05	3,05	2,96	2,98	3,03
<b>SEER <sup>2)3)</sup></b>			<b>4,40</b>	<b>4,53</b>	<b>4,53</b>	<b>4,68</b>	<b>4,45</b>	<b>4,50</b>	<b>4,55</b>
$\eta_{s,c}$ <sup>2)3)</sup>			<b>173</b>	<b>178</b>	<b>178</b>	<b>184</b>	<b>175</b>	<b>177</b>	<b>179</b>
Nominal water flow (in the evaporator)	m <sup>3</sup> /h		7,8	8,9	11,4	12,6	15,6	17,9	21,2
Sound power (STD fan)	dB(A)		81	81	81	81	84	84	84
Sound pressure at 10 m (STD fan) <sup>4)</sup>	dB(A)		48,8	48,8	48,8	48,8	51,8	51,8	51,8
<b>ECOi-W AQUA 45-125 H - heat pump</b>			<b>P-AQAE0045HA</b>	<b>P-AQAE0055HA</b>	<b>P-AQAE0065HA</b>	<b>P-AQAE0075HA</b>	<b>P-AQAE0090HA</b>	<b>P-AQAE0105HA</b>	<b>P-AQAE0125HA</b>
Cooling capacity <sup>1)</sup>	kW		44,3	50,9	64,1	71,0	88,7	101,0	119,0
Input power <sup>1)</sup>	kW		15,9	18,0	21,8	24,0	30,6	34,8	40,4
EER <sup>1)</sup>			2,78	2,83	2,94	2,95	2,90	2,90	2,96
<b>SEER <sup>2)</sup></b>			<b>4,20</b>	<b>4,41</b>	<b>4,51</b>	<b>4,63</b>	<b>4,40</b>	<b>4,44</b>	<b>4,49</b>
$\eta_{s,c}$ <sup>2)</sup>			<b>165</b>	<b>174</b>	<b>177</b>	<b>182</b>	<b>173</b>	<b>175</b>	<b>177</b>
Nominal water flow (in the evaporator)	m <sup>3</sup> /h		8,0	9,2	11,3	12,3	15,7	18,2	20,9
Heating capacity <sup>5)</sup>	kW		48,5	58,2	67,3	76,0	88,2	101,0	119,0
Input power <sup>5)</sup>	kW		17,3	20,4	22,5	24,3	33,8	38,4	45,5
COP <sup>5)</sup>			2,80	2,86	2,99	3,12	2,61	2,63	2,62
COP <sup>6)</sup>			3,89	3,83	3,80	3,82	3,80	3,80	3,82
<b>SCOP <sup>2)7)</sup></b>			<b>3,38</b>	<b>3,38</b>	<b>3,55</b>	<b>3,53</b>	<b>3,40</b>	<b>3,43</b>	<b>3,43</b>
<b>Energy efficiency class <sup>2)7)</sup></b>		<b>A+++ to D</b>	<b>A+</b>	<b>A+</b>	<b>A+</b>	<b>A+</b>	—	—	—
$\eta_{s,h}$ <sup>2)7)</sup>			<b>132</b>	<b>132</b>	<b>139</b>	<b>138</b>	<b>133</b>	<b>134</b>	<b>134</b>
Nominal water flow (in the evaporator)	m <sup>3</sup> /h		8,4	10,2	11,7	13,2	15,3	17,6	20,7
Sound power (STD fan)	dB(A)		81	81	81	81	84	84	84
Sound pressure at 10 m (STD fan) <sup>4)</sup>	dB(A)		48,8	48,8	48,8	48,8	51,8	51,8	51,8
<b>ECOi-W AQUA 45-125 E - condensing unit</b>			<b>P-AQAE0045EA</b>	<b>P-AQAE0055EA</b>	<b>P-AQAE0065EA</b>	<b>P-AQAE0075EA</b>	<b>P-AQAE0090EA</b>	<b>P-AQAE0105EA</b>	<b>P-AQAE0125EA</b>
Cooling capacity <sup>8)</sup>	kW		57,4	64,5	72,4	79,3	104,0	120,0	136,0
Input power <sup>8)</sup>	kW		19,5	22,3	24,4	27,2	39,3	43,0	51,3
EER <sup>8)</sup>			2,94	2,89	2,97	2,91	2,65	2,79	2,66
Sound power	dB(A)		80	80	80	80	83	83	83

Physical features

<b>ECOi-W AQUA 45-125 C/H - chiller / heat pump</b>			<b>45</b>	<b>55</b>	<b>65</b>	<b>75</b>	<b>90</b>	<b>105</b>	<b>125</b>	
Dimension	Height (STD / HPF)	mm	1986 / 2025	1986 / 2025	1986 / 2026	1986 / 2026	2286 / 2379	2286 / 2379	2286 / 2379	
	Width	mm	1160	1160	1160	1160	1160	1160	1160	
	Length w/o / w water tank	mm	2180 / 2680	2180 / 2680	2180 / 2680	2180 / 2680	2180 / 2680	2180 / 2680	2180 / 2680	
Operating weight w/o / w water tank - 1 pump			kg	545 / 1010	545 / 1010	615 / 1080	615 / 1080	795 / 1260	905 / 1370	925 / 1390
<b>Water connections</b>										
Type of water connections (evaporator)			Male gas threaded BSPP ISO 228	Male gas threaded BSPP ISO 228	Male gas threaded BSPP ISO 228	Male gas threaded BSPP ISO 228	Male gas threaded BSPP ISO 228	Male gas threaded BSPP ISO 228	Male gas threaded BSPP ISO 228	
Water inlet/outlet diameter			Inch	2	2	2	2	2½	2½	2½
<b>ECOi-W AQUA 45-125 E - condensing unit</b>			<b>45</b>	<b>55</b>	<b>65</b>	<b>75</b>	<b>90</b>	<b>105</b>	<b>125</b>	
Operating weight			kg	490	490	560	560	740	850	870
Dimension H x W x L			mm	1986 x 1160 x 2180	1986 x 1160 x 2180	1986 x 1160 x 2180	1986 x 1160 x 2180	2286 x 1160 x 2180	2286 x 1160 x 2180	2286 x 1160 x 2180
<b>Refrigerant connections</b>										
Liquid line			Inch	5/8	5/8	5/8	5/8	7/8	7/8	7/8
Suction line			Inch	1 5/8	1 5/8	1 5/8	1 5/8	1 5/8	1 5/8	1 5/8

1) According EN14511-2013: chilled water inlet/outlet temperature: 12/7 °C, outdoor ambient temperature 35 °C DB. 2) According EN14825. 3) ErP compliant: following COMMISSION REGULATION (EU) 2016/2281. 4) Sound pressures refer to ISO 3744 standard, parallelepiped shape. 5) According EN14511-2013: warm water inlet/outlet temperature: 40/45 °C, outdoor ambient temperature 7 °C DB/6 °C WB. 6) According EN14511-2013: warm water inlet/outlet temperature: 30/35 °C, outdoor ambient temperature 7 °C DB/6 °C WB. 7) ErP compliant: following COMMISSION REGULATION (EU) No 813/2013. 8) Data refers to 7 °C leaving chilled water temperature and 35 °C condenser air temperature, according EN14511-2013 standard. \* w/o: without, w: with.

Accessories and options

- Anti-vibration rubber mount / spring dampers
- BACnet IP or BACnet MSTP
- Desuperheater
- Fan speed control
- Finned coil blygold treatment (upon request) or epoxy
- Electrical heater high or low power (H type only)

Accessories and options

- Super low noise (S): acoustic box around the compressors
- High pressure fan (HPF)
- Modbus TCP/IP
- Outdoor coil protection grid
- Refrigerant gauges HP/LP
- Remote control

Accessories and options

- Shut off valves
- Soft starter
- SRC - mini BMS controller
- Variable or fixed\* speed pumps
- Water tank 300 l
- Without neutral (upon request)
- Water pressure switch

\* Not available with ECOi-W AQUA C units due to Ecodesign compliance.





# ECOi-W AQUA 140-210 C/H - R410A

Air cooled chillers and heat pumps.

Cooling capacity: 125,4 to 208,8 kW.

Heating capacity: 143,7 to 217,6 kW.



## The range at a glance

- 2 versions: C (chiller) and H (heat pump)
- 5 sizes
- SEER up to 4,40
- SCOP up to 3,36

## Advantages

- Very high performances
- Low noise units
- Wide operating limits
- Easy maintenance: great accessibility to the internal components
- Low footprint
- Patented antifrost coil
- Smart defrost technology: 1 defrost every 130 minutes for a constant LWT even at very low OAT (H type)
- Optimised for partial load operation
- 100% factory tested

## Operating limits

To be confirmed with AC SELECT:

<https://acselect.panasonic.eu/>

Ambient temperature (chiller and heat pump).

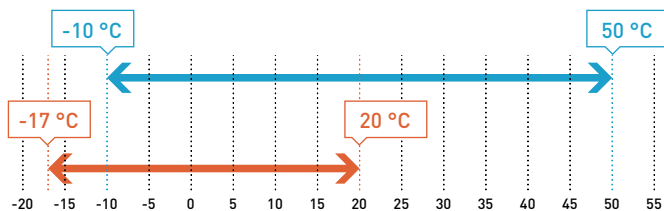

Leaving water temperature (chiller and heat pump).

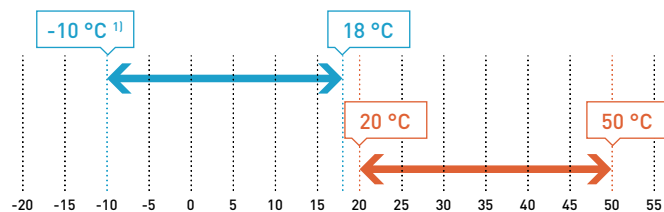

1) With glycol, 5 °C without glycol.

## Equipment

- 2 refrigerant circuits, each equipped with tandem scroll compressors for a higher efficiency at partial load
- Stainless steel plate heat exchanger with closed cell synthetic foam
- Finned coil condenser constructed with seamless copper tubes mechanically expanded into aluminium fins - Bluefin treatment for H type
- Hydraulic circuit without pump
- Complete integrated control system with an external control panel that displays the operating parameters and alarms
- Modbus RTU communication protocol as standard
- Super low noise units: acoustic box around the compressors
- Patented antifrost coil (H type)
- Night mode for energy savings and reduced sound levels
- Double water set point (H type)
- Water compensation curve control
- Return and leaving water temperature control
- Water filter and water flow switch
- Phase sequence monitor

## AC SELECT.

Smart and user-friendly the new air conditioning selection program: <https://acselect.panasonic.eu/>





## Technical performance

	Voltage	V	400	400	400	400	400
Power supply	Phase		Three phase	Three phase	Three phase	Three phase	Three phase
	Frequency	Hz	50	50	50	50	50
	<b>Size</b>		<b>140</b>	<b>150</b>	<b>170</b>	<b>190</b>	<b>210</b>
<b>ECOi-W AQUA 140-210 C - chiller</b>			<b>P-AQAE0140CA</b>	<b>P-AQAE0150CA</b>	<b>P-AQAE0170CA</b>	<b>P-AQAE0190CA</b>	<b>P-AQAE0210CA</b>
Cooling capacity <sup>1)</sup>	kW	132	146	164	181	208	
Input power <sup>1)</sup>	kW	43,1	47,6	54,8	61,1	69,8	
EER <sup>1)</sup>		3,06	3,07	2,99	2,96	2,98	
<b>SEER <sup>2)3)</sup></b>		<b>4,40</b>	<b>4,45</b>	<b>4,38</b>	<b>4,40</b>	<b>4,25</b>	
$\eta_{s,c}$ <sup>2)3)</sup>		<b>173</b>	<b>175</b>	<b>172</b>	<b>173</b>	<b>167</b>	
Nominal water flow (in the evaporator)	m <sup>3</sup> /h	22,7	25,1	28,2	31,1	35,8	
Sound power (STD fan)	dB(A)	85	85	87	88	88	
Sound pressure at 10 m (STD fan) <sup>4)</sup>	dB(A)	53,4	53,4	55,0	56,1	56,1	
<b>ECOi-W AQUA 140-210 H - heat pump</b>			<b>P-AQAE0140HA</b>	<b>P-AQAE0150HA</b>	<b>P-AQAE0170HA</b>	<b>P-AQAE0190HA</b>	<b>P-AQAE0210HA</b>
Cooling capacity <sup>1)</sup>	kW	128	142	164	178	208	
Input power <sup>1)</sup>	kW	43,2	47,7	54,7	61,3	69,7	
EER <sup>1)</sup>		2,97	2,98	3,00	2,90	2,98	
<b>SEER <sup>2)</sup></b>		<b>4,39</b>	<b>4,36</b>	<b>4,31</b>	<b>4,23</b>	<b>4,28</b>	
$\eta_{s,c}$ <sup>2)</sup>		<b>173</b>	<b>171</b>	<b>169</b>	<b>166</b>	<b>168</b>	
Nominal water flow (in the evaporator)	m <sup>3</sup> /h	21,6	23,7	25,9	30,2	33,7	
Heating capacity <sup>5)</sup>	kW	144	154	170	195	218	
Input power <sup>5)</sup>	kW	45,8	50,2	55,4	67,5	78,3	
COP <sup>5)</sup>		3,14	3,06	3,07	2,89	2,78	
COP <sup>6)</sup>		3,84	3,82	3,81	3,82	3,82	
<b>SCOP <sup>2)7)</sup></b>		<b>3,30</b>	<b>3,33</b>	<b>3,30</b>	<b>3,28</b>	<b>3,23</b>	
$\eta_{s,h}$ <sup>2)7)</sup>		<b>129</b>	<b>130</b>	<b>129</b>	<b>128</b>	<b>126</b>	
Nominal water flow (in the evaporator)	m <sup>3</sup> /h	24,8	26,5	29,6	33,9	37,9	
Sound power	dB(A)	85	85	87	88	88	
Sound pressure at 10 m (STD fan) <sup>4)</sup>	dB(A)	53,4	53,4	55	56,1	56,1	

## Physical features

<b>ECOi-W AQUA 140-210 C/H - chiller / heat pump</b>		<b>140</b>	<b>150</b>	<b>170</b>	<b>190</b>	<b>210</b>	
Dimension	Height	mm	2295	2295	2321	2321	2321
	Width	mm	2210	2210	2210	2210	2210
	Length w/o / w water tank	mm	2856 / 3666	2856 / 3666	2856 / 3666	2856 / 3666	2856 / 3666
Operating weight w/o / w water tank - 1 pump	kg	1685 / 2139	1705 / 2159	1798 / 2253	1891 / 2343	2201 / 2653	
<b>Water connections</b>							
Type of water connections (evaporator)		Victaulic®	Victaulic®	Victaulic®	Victaulic®	Victaulic®	
Water inlet/outlet diameter	Inch	2 ½	2 ½	2 ½	2 ½	2 ½	

1) According EN14511-2013: chilled water inlet/outlet temperature: 12/7 °C, outdoor ambient temperature 35 °C DB. 2) According EN14825. 3) ErP compliant: following COMMISSION REGULATION (EU) 2016/2281. 4) Sound pressures refer to ISO 3744 standard, parallelepiped shape. 5) According EN14511-2013: warm water inlet/outlet temperature: 40/45 °C, outdoor ambient temperature 7 °C DB/6 °C WB. 6) According EN14511-2013: warm water inlet/outlet temperature: 30/35 °C, outdoor ambient temperature 7 °C DB/6 °C WB. 7) ErP compliant: following COMMISSION REGULATION (EU) No 813/2013.

\* w/o: without, w: with.

### Accessories and options

Anti-vibration rubber mount / spring dampers  
BACnet IP and BACnet MSTP  
Desuperheater (upon request)  
Fan speed control  
Finned coil blygold treatment (upon request) and epoxy  
Hydraulic gauges

### Accessories and options

Modbus TCP/IP  
Outdoor coil protection grid  
Nordic pack (H type only)  
Refrigerant gauges HP/LP  
Remote control  
Shut off valves  
Soft starter

### Accessories and options

SRC - mini BMS controller  
Variable or fixed\* speed pumps  
Water tank 300 l  
Without neutral  
Water pressure switch

\* ECOi-W AQUA C units can't be Ecodesign compliant with this option.





# ECOi-W AQUA-Z 50-170 C/H - R32

Air cooled chillers and heat pumps.

Cooling capacity: 51,6 to 173,0 kW.

Heating capacity: 51,7 to 180,0 kW.

R32  
REFRIGERANT



## The range at a glance

- 2 versions: C (chiller) and H (heat pump)
- 10 sizes
- SEER up to 4,88 (STD AC) / 5,31 (STD EC)
- SCOP up to 3,72 (STD AC) / 4,10 (STD EC)
- 2 configurations: STD (standard) and HPF (high pressure fan)
- 2 fan types: AC (standard fan) and EC (high efficiency fan)
- 2 acoustic options: STD (standard) and S (super low noise)

## Advantages

- Low GWP R32 refrigerant (GWP= 675)
- Very high efficiency
- Wide operating limits
- Low footprint: one of the smallest footprint on the market with only 2,53 m<sup>2</sup> for sizes 50 - 130 and 4,36 m<sup>2</sup> for sizes 150 - 170
- Reduced sound levels: S version (super low noise) with EC fan and compressor sound jackets
- New advanced control system
- Easy maintenance: great accessibility to the internal components
- Cascade controller available for multi-system operation
- SG Ready
- 100% factory tested

## Operating limits

To be confirmed with AC SELECT:

<https://acselect.panasonic.eu/>

Ambient temperature.

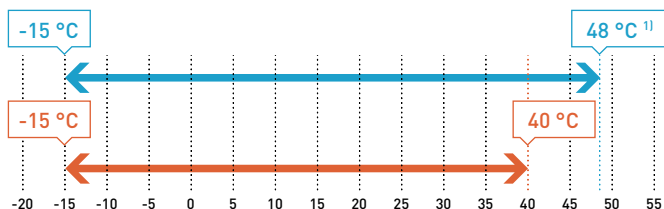

Leaving water temperature.

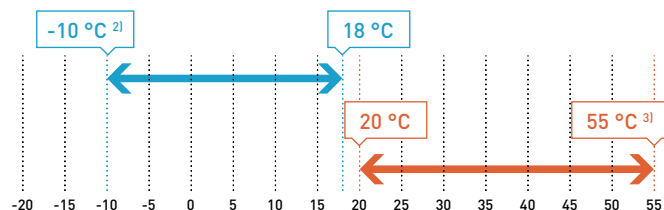

1) 47 °C for sizes 150 - 170.

2) With glycol, 5 °C without glycol.

3) 53 °C for sizes 150 - 170.

## Equipment

- 1 refrigerant circuit with tandem scroll compressors for a higher efficiency at partial load
- Stainless steel plate heat exchanger insulated with closed cell synthetic foam
- Finned coil condenser constructed with seamless copper tubes mechanically expanded into aluminium fins - Bluefin treatment for H type
- Hydraulic circuit without pump
- Complete integrated control system with an external control panel that displays the operating parameters and alarms
- Modbus RTU, Modbus TCP/IP, BACnet MSTP or BACnet IP
- Night mode for energy savings and reduced sound levels
- Electronic expansion valve
- Water compensation curve control
- Return and leaving water temperature control
- External switch (cooling/heating, night mode, load shedding)
- Water filter and water flow switch
- Phase sequence monitor
- Without neutral

## AC SELECT.

Smart and user-friendly the new air conditioning selection program: <https://acselect.panasonic.eu/>





Technical performance

	Voltage	V	400	400	400	400	400	400	400	400	400	400
Power supply	Phase		Three phase	Three phase	Three phase	Three phase	Three phase	Three phase	Three phase	Three phase	Three phase	Three phase
	Frequency	Hz	50	50	50	50	50	50	50	50	50	50
Size			<b>50</b>	<b>60</b>	<b>70</b>	<b>75</b>	<b>85</b>	<b>100</b>	<b>115</b>	<b>130</b>	<b>150</b>	<b>170</b>
<b>ECOi-W AQUA-Z 50-170 C - chiller</b>	<b>P-AQAZ****CA</b>	<b>0050</b>	<b>0060</b>	<b>0070</b>	<b>0075</b>	<b>0085</b>	<b>0100</b>	<b>0115</b>	<b>0130</b>	<b>0150</b>	<b>0170</b>	
Cooling capacity <sup>1)</sup>	kW		51,6	57,6	69,7	78,2	82,8	100	116	126	154	173
Input power <sup>1)</sup>	kW		16,5	19,6	22,4	24	26,8	31,4	37,4	42,3	47,4	55,7
EER (STD AC / STD EC) <sup>*1)</sup>			3,13/3,25	2,94/3,03	3,11/3,29	3,26/3,41	3,09/3,23	3,18/3,30	3,10/3,20	2,98/3,07	3,25/3,38	3,11/3,20
<b>SEER (STD AC / STD EC) <sup>*2)3)</sup></b>			<b>4,60/5,05</b>	<b>4,59/5,02</b>	<b>4,61/5,31</b>	<b>4,72/5,29</b>	<b>4,45/4,96</b>	<b>4,88/5,19</b>	<b>4,59/5,01</b>	<b>4,43/4,71</b>	<b>4,70/5,22</b>	<b>4,68/5,16</b>
$\eta_{s,c}$ (STD AC / STD EC) <sup>*2)3)</sup>			<b>180,9 / 198,9</b>	<b>180,5 / 197,8</b>	<b>181,3 / 209,6</b>	<b>185,6 / 208,7</b>	<b>175,0 / 195,6</b>	<b>192,3 / 204,9</b>	<b>180,5 / 197,3</b>	<b>174,2 / 185,6</b>	<b>184,8 / 205,6</b>	<b>184,2 / 203,2</b>
Nominal water flow (in the evaporator)	m <sup>3</sup> /h		9,2	10,6	12,2	13,2	14,7	17,9	21,1	23,5	27,2	30,7
Sound power (STD AC / S) *	dB(A)		83 / 81	84 / 81	81 / 78	81 / 78	84 / 82	86 / 83	87 / 84	87 / 84	89 / 86	91 / 88
Sound pressure at 10 m (STD AC / S) <sup>*4)</sup>	dB(A)		51 / 49	52 / 49	50 / 47	49 / 46	52 / 50	54 / 51	55 / 52	55 / 53	57 / 54	59 / 56
<b>ECOi-W AQUA-Z 50-170 H - heat pump</b>	<b>P-AQAZ****HA</b>	<b>0050</b>	<b>0060</b>	<b>0070</b>	<b>0075</b>	<b>0085</b>	<b>0100</b>	<b>0115</b>	<b>0130</b>	<b>0150</b>	<b>0170</b>	
Cooling capacity <sup>1)</sup>	kW		51,1	57	69	77,4	82	99,3	115	125	152	170
Input power <sup>1)</sup>	kW		16,7	19,8	22,6	24,3	27,1	31,8	37,7	42,7	47,9	57,1
EER (STD AC / STD EC) <sup>*1)</sup>			3,06/3,17	2,88/2,97	3,05/3,22	3,19/3,35	3,03/3,17	3,12/3,25	3,05/3,14	2,93/3,00	3,17/3,30	2,98/3,07
EER (STD AC / STD EC) <sup>*5)</sup>			3,53/3,67	3,40/3,50	3,57/3,64	3,78/3,96	3,52/3,66	3,63/3,76	3,51/3,54	3,39/3,50	3,63/3,76	3,39/3,56
<b>SEER (STD AC / STD EC) <sup>*2)</sup></b>			<b>4,46/4,83</b>	<b>4,42/4,50</b>	<b>4,51/5,04</b>	<b>4,61/4,99</b>	<b>4,33/4,80</b>	<b>4,77/4,93</b>	<b>4,44/4,82</b>	<b>4,23/4,51</b>	<b>4,59/5,04</b>	<b>4,49/4,92</b>
$\eta_{s,c}$ (STD AC / STD EC) <sup>*2)</sup>			<b>175,2 / 190,2</b>	<b>173,6 / 176,9</b>	<b>177,5 / 198,8</b>	<b>181,5 / 196,7</b>	<b>170,3 / 188,9</b>	<b>187,7 / 194,1</b>	<b>174,6 / 190,0</b>	<b>166 / 177,2</b>	<b>180,5 / 198,7</b>	<b>176,6 / 193,8</b>
Nominal water flow (in the evaporator)	m <sup>3</sup> /h		8,7	10,6	12,2	13,2	14,7	17,9	21,1	23,5	27,2	30,7
Heating capacity <sup>6)</sup>	kW		51,7	59,7	71,8	78,5	86,5	107,6	122,3	137,5	159,1	180,1
Input power <sup>6)</sup>	kW		16,5	19,3	22,1	24,2	27,2	32,5	37,0	41,0	48,2	54,5
COP (STD AC / STD EC) <sup>*4)</sup>			3,12/3,27	3,10/3,21	3,24/3,43	3,24/3,41	3,19/3,30	3,31/3,45	3,31/3,42	3,36/3,42	3,30/3,48	3,31/3,40
COP (STD AC / STD EC) <sup>*7)</sup>			3,81/4,00	3,80/3,92	3,92/4,21	3,91/4,16	3,92/4,16	3,99/4,19	4,10/4,26	4,04/4,12	4,07/4,31	4,02/4,16
<b>SCOP (STD AC / STD EC) <sup>*2)8)</sup></b>			<b>3,53/3,90</b>	<b>3,54/3,94</b>	<b>3,47/3,71</b>	<b>3,65/3,80</b>	<b>3,60/4,02</b>	<b>3,64/4,10</b>	<b>3,66/4,02</b>	<b>3,72/3,97</b>	<b>3,57/4,04</b>	<b>3,60/3,95</b>
<b>Energy efficiency class (STD AC / STD EC) <sup>*2)7)</sup></b>	<b>A+++ to D</b>		<b>A+ / A+</b>	<b>A+ / A+</b>	<b>A+ / A++</b>	<b>A+ / A++</b>	<b>A+ / A++</b>	<b>A+ / A++</b>	<b>- / -</b>	<b>- / -</b>	<b>- / -</b>	<b>- / -</b>
$\eta_{s,h}$ (STD AC / STD EC) <sup>*2)7)</sup>			<b>138,0 / 152,8</b>	<b>138,5 / 154,5</b>	<b>135,6 / 145,3</b>	<b>143,2 / 148,8</b>	<b>141,2 / 157,8</b>	<b>142,5 / 160,9</b>	<b>143,2 / 157,9</b>	<b>145,7 / 155,9</b>	<b>139,9 / 158,4</b>	<b>140,9 / 155,2</b>
Nominal water flow (in the evaporator)	m <sup>3</sup> /h		9,3	10,7	12,5	13,9	15,0	18,3	21,5	23,9	27,5	31,7
Sound power (STD AC / S) *	dB(A)		83 / 81	84 / 81	81 / 78	81 / 78	84 / 82	86 / 83	87 / 84	87 / 84	89 / 86	91 / 88
Sound pressure at 10 m (STD AC / S) <sup>*4)</sup>	dB(A)		51 / 49	52 / 49	50 / 47	50 / 46	52 / 50	54 / 51	55 / 52	56 / 53	57 / 54	59 / 56

Physical features

<b>ECOi-W AQUA-Z 50-170 C/H - chiller / heat pump</b>		<b>50</b>	<b>60</b>	<b>70</b>	<b>75</b>	<b>85</b>	<b>100</b>	<b>115</b>	<b>130</b>	<b>150</b>	<b>170</b>	
Dimension	Height (STD / EC/HPF)	mm	1986/2034	1986/2034	1986/2034	1986/2034	2286/2334	2286/2334	2286/2334	2286/2334	2285/2333	2285/2333
	Width	mm	1160	1160	1160	1160	1160	1160	1160	1160	1151	1151
	Length without water tank	mm	2180	2180	2180	2180	2180	2180	2180	2180	3789	3789
Operating weight without water tank - 1 pump	kg	527	547	621	637	701	731	813	815	1265	1279	
<b>Water connections</b>												
Type of water connections (evaporator)		Male gas threaded BSPP ISO 228	Male gas threaded BSPP ISO 228	Male gas threaded BSPP ISO 228	Male gas threaded BSPP ISO 228	Male gas threaded BSPP ISO 228	Male gas threaded BSPP ISO 228	Male gas threaded BSPP ISO 228	Male gas threaded BSPP ISO 228	Male gas threaded BSPP ISO 228	Male gas threaded BSPP ISO 228	Male gas threaded BSPP ISO 228
Water inlet/outlet diameter	Inch	2	2	2	2	2 1/2	2 1/2	2 1/2	2 1/2	2 1/2	2 1/2	2 1/2

1) According EN14511-2018: chilled water inlet/outlet temperature: 12/7 °C, outdoor ambient temperature 35 °C DB. 2) According EN14825. 3) ErP compliant: following COMMISSION REGULATION (EU) 2016/2281. 4) Sound pressures refer to ISO 3744 standard, parallelepiped shape. 5) According EN14511-2018: chilled water inlet/outlet temperature: 23/18 °C, outdoor ambient temperature 35 °C DB. 6) According EN14511-2018: warm water inlet/outlet temperature: 40/45 °C, outdoor ambient temperature 7 °C DB/6 °C WB. 7) According EN14511-2018: warm water inlet/outlet temperature: 30/35 °C, outdoor ambient temperature 7 °C DB/6 °C WB. 8) ErP compliant: following COMMISSION REGULATION (EU) No 813/2013. \* STD AC: standard version with AC fan, STD EC: standard version with high efficiency EC fan, S: super low noise version with high efficiency EC fan + compressor sound jackets.

Accessories and options
Anti-vibration rubber mount / spring dampers *
Cascade controller *
Compressor jackets (standard for S versions)
Desuperheater
Electrical heater for the water tank
Fin&Tube Al/Cu with epoxy / Blygold treatment
High efficiency EC fan

Accessories and options
High pressure fan (HPF)
Outdoor coil protection grid
Power factor corrector capacitors
Refrigerant gauges HP/LP
Remote control kit *
Shut off valves
Sofstarter

Accessories and options
Variable speed pumps
Water pressure switch *
Water tank 300 l
Without neutral
Communication protocols: Modbus RTU (Std.), Modbus TCP/IP, BACnet MSTP, BACnet IP

\* Field-installed accessories. All other accessories are factory-installed.



# ECOi-W AQUA-Z DC 150-380 C/H · R32

Air cooled chillers and heat pumps.

Cooling capacity: 151 to 377 kW.

Heating capacity: 154 to 384 kW.

R32  
REFRIGERANT



## The range at a glance

- 2 versions: C (chiller) and H (heat pump)
- 10 sizes for C version and 13 sizes for H version
- 3 different chassis
- SEER up to 4,93 (STD AC) / 5,23 (STD EC)
- SCOP up to 3,90 (STD AC) / 4,00 (STD EC)
- 2 configurations: STD (standard) and HPF (high pressure fan)
- 2 fan types: AC (standard fan) and EC (high efficiency fan)
- 2 acoustic options: STD (standard) and S (super low noise)

## Advantages

- Low GWP R32 refrigerant (GWP= 675)
- Double circuit units able to work in partial load from around 20% of total capacity
- Very high efficiency
- Wide operating limits
- Reduced sound levels: S version (super low noise) with EC fan and compressor sound jackets for sizes 150 - 380, additional compressor box for sizes 190 - 380
- New intelligent control logic
- Easy maintenance: great accessibility to the internal components
- Cascade controller available for multi-system operation with capacity boost up to 3040 kW
- SG Ready
- 100% factory tested

## Operating limits

To be confirmed with AC SELECT:

<https://acselect.panasonic.eu/>

Ambient temperature.

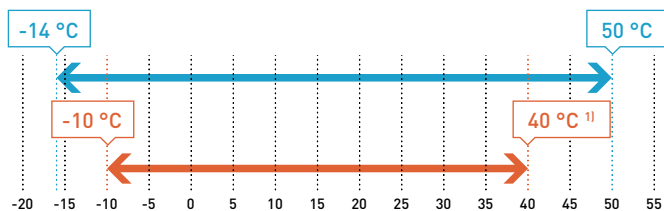

Leaving water temperature.

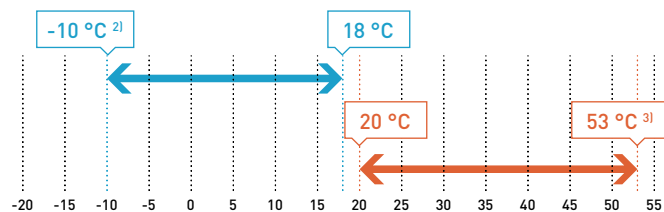

1) With EC fans.

2) With glycol, 5 °C without glycol.

3) 55 °C sizes 150 - 170.

## Equipment

- 2 refrigerant circuits with tandem scroll compressors for a higher efficiency at partial load
- Stainless steel plate heat exchanger insulated with closed cell synthetic foam
- Microchannel coils only for C version (sizes 190-380)
- Fin&Tube coil condenser constructed with seamless copper tubes mechanically expanded into aluminium fins
  - Bluefin treatment for H version
- Hydraulic circuit without pump
- Complete integrated control system with an external control panel that displays the operating parameters and alarms
- Modbus RTU, Modbus TCP/IP, BACnet MSTP or BACnet IP
- Digital input for Night Mode, Demand mode or Eco Mode for energy savings and reduced sound levels
- Electronic expansion valve
- Water compensation curve control
- Return and leaving water temperature control
- Water flow switch (sizes 150 - 170)
- Differential pressure switch (sizes 190 - 380)
- Phase sequence monitor
- Automatic circuit breaker
- Without neutral



Technical performance

Size		150	170	190	210	230	260	290	320	350	380			
<b>ECOi-W AQUA-Z DC 150-380 C - chiller</b>	<b>P-AQADZ****CA</b>	<b>STD AC / STD EC</b>	<b>STD AC / STD EC</b>	<b>STD AC / STD EC</b>	<b>STD AC / STD EC</b>	<b>STD AC / STD EC</b>	<b>STD AC / STD EC</b>	<b>STD AC / STD EC</b>	<b>STD AC / STD EC</b>	<b>STD AC / STD EC</b>	<b>STD AC / STD EC</b>			
Cooling capacity <sup>1)</sup>	kW	151,0/151,0	170,0/170,0	189,0/189,0	212,0/214,0	229,0/229,0	260,0/260,0	307,0/307,0	326,0/325,0	346,0/347,0	377,0/377,0			
Input power <sup>1)</sup>	kW	49,7/49,0	56,7/55,9	59,4/57,3	69,1/66,5	75,1/72,7	90,0/87,8	95,9/92,5	104,2/100,0	112,0/108,1	126,9/122,8			
EER <sup>1)</sup>		3,04/3,08	3,00/3,04	3,18/3,30	3,07/3,22	3,05/3,15	2,89/2,96	3,20/3,32	3,13/3,25	3,09/3,21	3,0/3,1			
<b>SEER <sup>2)</sup></b>		<b>4,93/5,2</b>	<b>4,90/5,15</b>	<b>4,68/5,23</b>	<b>4,62/5,20</b>	<b>4,48/4,90</b>	<b>4,40/4,79</b>	<b>4,63/5,13</b>	<b>4,33/5,12</b>	<b>4,43/4,79</b>	<b>4,35/4,8</b>			
$\eta_{s,c}$ <sup>2)</sup>	%	<b>194,0/204,0</b>	<b>192,8/203,0</b>	<b>184,3/206,1</b>	<b>181,8/204,8</b>	<b>176,3/192,9</b>	<b>173,1/188,4</b>	<b>182,0/202,2</b>	<b>170,0/188,8</b>	<b>174,2/188,5</b>	<b>171,0/188,8</b>			
Cooling capacity (A 35 °C, W 23/18 °C)	kW	191,0/193,0	213,0/217,0	242,0/243,0	269,0/271,0	294,0/295,0	331,0/339,7	389,0/390,0	415,0/412,0	442,0/444,0	483,0/484,0			
Input power (A 35 °C, W 23/18 °C)	kW	53,8/52,7	62,1/61,2	64,2/61,3	74,5/71,6	82,9/79,9	98,2/96,8	103,0/99,4	112,0/109,0	123,0/119,0	139,0/136,0			
Water flow	m <sup>3</sup> /h	26,0/25,9	29,2/29,2	32,5/32,5	36,5/36,8	39,4/39,4	44,7/44,7	52,8/52,8	56,1/55,9	59,5/59,7	64,8/64,8			
Sound power [STD]	dB(A)	89,6/89,0	90,4/89,9	91,1/90,9	91,5/91,3	92,0/91,9	92,4/92,3	93,3/93,1	94,3/94,2	95,2/95,1	95,4/95,3			
Sound pressure [STD] *	dB(A)	57,5/56,9	58,3/57,8	59,0/58,8	59,4/59,2	59,9/59,8	60,3/60,2	61,1/60,9	62,1/62,0	63,0/62,9	63,2/63,1			
Sound power [S]	dB(A)	-/85,0	-/85,4	-/87,2	-/87,4	-/87,6	-/87,8	-/88,6	-/89,7	-/90,1	-/90,3			
Sound pressure [S] *	dB(A)	-/52,9	-/53,3	-/55,1	-/55,3	-/55,5	-/55,7	-/56,4	-/57,5	-/57,9	-/58,1			
<b>Size</b>		<b>150</b>	<b>170</b>	<b>190</b>	<b>210</b>	<b>220</b>	<b>230</b>	<b>260</b>	<b>270</b>	<b>290</b>	<b>320</b>	<b>350</b>	<b>380</b>	
<b>ECOi-W AQUA-Z DC 150-380 H - heat pump</b>	<b>P-AQADZ****HA</b>	<b>STD AC / STD EC</b>	<b>STD AC / STD EC</b>	<b>STD AC / STD EC</b>	<b>STD AC / STD EC</b>	<b>STD AC / STD EC</b>	<b>STD AC / STD EC</b>	<b>STD AC / STD EC</b>	<b>STD AC / STD EC</b>	<b>STD AC / STD EC</b>	<b>STD AC / STD EC</b>	<b>STD AC / STD EC</b>	<b>STD AC / STD EC</b>	
Cooling capacity <sup>1)</sup>	kW	150/150	167/167	184/183	204/204	208	224/224	251/251	265	291,1/289,3	295	307,7/310,7	330/331	364/364,3
Input power <sup>1)</sup>	kW	49,7/49,0	56,6/55,9	62,0/59,6	72,1/69,9	67,3	76,7/74,4	93,0/90,6	83,1	101,3/96,6	93,1	107,5/103,3	114,2/110,0	131,7/128,1
Total EER <sup>1)</sup>		3,02/3,06	2,95/2,99	2,97/3,07	2,83/2,92	3,09	2,92/3,01	2,7/2,77	3,19	2,87/2,99	3,17	2,86/3,00	2,89/3,01	2,76/2,84
Total EER (A 35 °C, W 23/18 °C)		3,53/3,60	3,41/3,51	3,41/3,58	3,22/3,37	3,63	3,45/3,60	3,12/3,18	3,83	3,32/3,46	3,72	3,31/3,52	3,32/3,52	3,16/3,30
<b>SEER <sup>2)</sup></b>		<b>4,75/5,03</b>	<b>4,71/4,97</b>	<b>4,45/4,94</b>	<b>4,39/4,82</b>	<b>5,03</b>	<b>4,34/4,71</b>	<b>4,21/4,55</b>	<b>5,01</b>	<b>4,34/4,83</b>	<b>5,01</b>	<b>4,33/4,89</b>	<b>4,40/4,79</b>	<b>4,34/4,65</b>
$\eta_{s,c}$ <sup>2)</sup>	%	<b>187,1 / 198,1</b>	<b>185,3 / 195,7</b>	<b>175,2 / 194,6</b>	<b>172,5 / 189,6</b>	<b>198</b>	<b>170,6 / 185,5</b>	<b>165,5 / 179,1</b>	<b>197,5</b>	<b>170,4 / 190,1</b>	<b>197,3</b>	<b>170 / 192,4</b>	<b>172,9 / 188,5</b>	<b>170,5 / 182,9</b>
Water flow	m <sup>3</sup> /h	25,8/25,8	28,7/28,7	31,6/31,5	35,1/35,1	35,8	38,5/38,5	43,2/43,2	45,6	50,1/49,8	50,7	52,9/53,4	56,8/56,9	62,6/62,7
Heating capacity <sup>3)</sup>	kW	154/154	178/179	190/190	201/201	219	241/241	256,9/258,5	288	285,6/284,8	312	301,3/316,5	337/340	384/384,5
Input power <sup>3)</sup>	kW	48,8/48,2	54,9/54,4	61,3/58,6	68,5/65,9	67	75,4/72	87,6/85,0	88,3	97,5/93,2	94,6	103,2/100,1	111/107	128/122,4
Total COP <sup>3)</sup>		3,16/3,20	3,24/3,29	3,10/3,24	2,93/3,05	3,27	3,20/3,35	2,93/3,04	3,26	2,93/3,05	3,30	2,92/3,16	3,04/3,18	3,00/3,14
Total COP (A 7 °C, W 30/35 °C)		3,67/3,82	3,98/4,04	3,57/3,80	3,43/3,59	4,01	3,86/4,04	3,56/3,68	4,00	3,47/3,61	3,86	3,45/3,86	3,69/3,82	3,54/3,66
<b>SCOP <sup>4)</sup></b>		<b>3,83/4,00</b>	<b>3,90/4,00</b>	<b>3,46/3,89</b>	<b>3,44/3,90</b>	<b>3,86</b>	<b>3,64/3,99</b>	<b>3,52/3,85</b>	<b>3,82</b>	<b>3,51/3,91</b>	<b>3,92</b>	<b>3,50/3,85</b>	<b>3,50/3,87</b>	<b>3,66/3,95</b>
$\eta_{s,h}$ <sup>4)</sup>	%	<b>150 / 157,1</b>	<b>152,8 / 156,8</b>	<b>135,6 / 152,7</b>	<b>134,7 / 152,8</b>	<b>151,3</b>	<b>142,5 / 156,4</b>	<b>137,9 / 151</b>	<b>149,7</b>	<b>137,4 / 153,2</b>	<b>153,7</b>	<b>137 / 151,2</b>	<b>136,9 / 151,9</b>	<b>143,4 / 155,1</b>
Water flow	m <sup>3</sup> /h	26,5/26,5	30,6/30,8	32,7/32,7	34,6/34,6	37,7	41,5/41,5	44,2/44,5	49,5	49,1/49,0	53,7	51,8/54,4	58,0/58,5	66,0/66,1
Sound power [STD]	dB(A)	89,6/89,0	90,4/89,9	91,1/90,9	91,5/91,3	91,3	92,0/91,9	92,4/92,3	92,8	93,3/93,1	93,1	94,3/94,2	95,2/95,1	95,4/95,3
Sound pressure [STD] *	dB(A)	57,5/56,9	58,3/57,8	59,0/58,8	59,4/59,2	59,2	59,9/59,8	60,3/60,2	60,7	61,1/60,9	60,9	62,1/62,0	63,0/62,9	63,2/63,1
Sound power [S]	dB(A)	-/85,0	-/85,4	-/87,2	-/87,4	87,4	-/87,6	-/87,8	88,5	-/88,6	88,6	-/89,7	-/90,1	-/90,3
Sound pressure [S] *	dB(A)	-/52,9	-/53,3	-/55,1	-/55,3	55,3	-/55,5	-/55,7	56,4	-/56,4	56,4	-/57,5	-/57,9	-/58,1

Physical features

<b>ECOi-W AQUA-Z DC 150-380 C/H - chiller / heat pump</b>			150	170	190	210	220	230	260	270	290	300	320	350	380
Dimension	Height (STD AC)	mm	2240	2240	2250	2250	—	2250	2250	—	2250	—	2250	2250	2250
	Height (EC/HPF)	mm	2312	2312	2300	2300	2300	2300	2300	2300	2300	2300	2300	2300	2300
	Width	mm	1152	1152	2211	2211	2211	2211	2211	2211	2211	2211	2211	2211	2211
	Length	mm	3795	3795	2676	2676	2676	2676	2676	2676	3801	3801	3801	3801	3801

1) According EN14511-2018: chilled water inlet/outlet temperature: 12/7 °C, outdoor ambient temperature 35 °C DB. 2) According EN14825 and Following COMMISSION REGULATION (EU) 2016/2281. 3) According EN14511-2018: warm water inlet/outlet temperature: 40/45 °C, outdoor ambient temperature 7 °C DB/6 °C WB. 4) According EN14825 and Following COMMISSION REGULATION (EU) No 813/2013. \* Sound pressure levels calculated at 10 meters. Sound pressure levels refer to ISO 3744 standard, parallelepiped shape.

Accessories and options	
Anti-vibration rubber mount / spring dampers *	
Cascade controller *	
Desuperheater for sizes 190 - 380	
Energy meter for power input	
Fin&Tube Al/Cu with Epoxy / Blygold treatment	
High efficiency EC fan	
High pressure fan (HPF)	

Accessories and options	
Mechanical gauges kit (HP and LP manometers)	
Coil guards for sizes 150 - 170	
Chiller grilles and drain pan for sizes 190 - 380	
Power factor corrector capacitors	
Remote control kit *	
Shut off valves *	
Soft starter	

Accessories and options	
Super low noise (S) version	
Compressor jackets	
Compressor box for sizes 190 - 380	
Variable speed pumps	
Water filter *	
Water pressure switch	
Water tank	

\* Field-installed accessories. All other accessories are factory-installed.





# ECOi-W Aqv C/H/E - R410A

Air cooled chillers, heat pumps and condensing units.

Cooling capacity: 83,3 to 136,6 kW.

Heating capacity: 91,8 to 146,9 kW.



## Operating limits

To be confirmed with AC SELECT:

<https://acselect.panasonic.eu/>

Ambient temperature (chiller and heat pump).

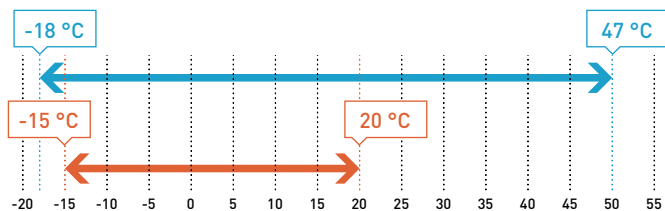

Leaving water temperature (chiller and heat pump).

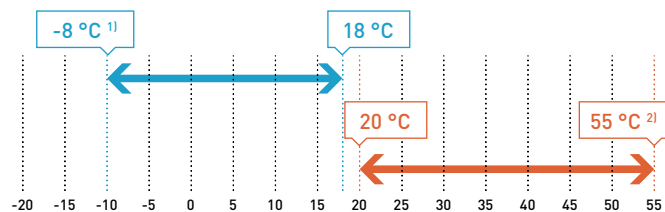

1) With glycol, 5 °C without glycol.

2) Leaving water temperature maximum 55 °C (external air temperature minimum 6 °C) to be confirm with AC SELECT selection software.

### ECOi-W Aqv 85-140 C/H - chiller / heat pump

Cooling	Outdoor air temperature	S	°C	From -18 to 44
		HT	°C	From -18 to 50 [85-115] From -18 to 47 [125-140]
Heating	Outdoor air temperature	S	°C	From -4 to 20
		Polar Version	°C	From -15 to 20
External static pressure		STD / HPF	Pa	0 / <120

### ECOi-W Aqv 85-140 E - condensing unit

Evaporating limit		°C	From 1 to 15
	STD	°C	From 0 to 48
Outdoor air temperature	S	°C	From -18 to 45
	HT	°C	From 0 to 50

## The range at a glance

- 3 versions: C (chiller), H (heat pump) and E (condensing unit)
- 6 sizes
- 3 configurations: STD (standard), HT (high temperature) and HPF (high pressure fan)
- 2 fan types: AC (standard fan) and EC (HSE model: high seasonal efficiency)
- 2 acoustic options: STD (standard) and S (super low noise)

## Advantages

- High seasonal performances: SEER up to 4,9
- Common configuration for the different versions: easy upgrade of the units in stock or on field
- Electronic expansion device: excellent control of superheating for the best performance at full and partial load and for a safe operation
- Microchannel coils: significant reduction on refrigerant charge and operating weight (C type)
- Compressor box: remarkable sound reduction even for the basic noise version
- Control platform: modular architecture, compressor envelope integration, corrective actions in border line areas, easy-friendly user interface

## Equipment

- 2 refrigerant circuits
- 4 scroll compressors (tandem)
- Plate evaporator (AISI 316)
- Microprocessor control
- Low operating water content in the plant
- Electronic expansion valve as standard
- Brine version for process application
- Polar version for extreme conditions
- E-coating coil treatment as standard
- Compressor acoustic box
- Compressor jackets (standard on S)
- Phase sequence control
- Water flow switch



## Technical performance

	Voltage	V	400	400	400	400	400	400
Power supply	Phase		Three phase	Three phase	Three phase	Three phase	Three phase	Three phase
	Frequency		Hz	50	50	50	50	50
Size			<b>85</b>	<b>95</b>	<b>105</b>	<b>115</b>	<b>125</b>	<b>140</b>
<b>ECOi-W AQV 85-140 C - chiller</b>			<b>P-AQVE0085CA</b>	<b>P-AQVE0095CA</b>	<b>P-AQVE0105CA</b>	<b>P-AQVE0115CA</b>	<b>P-AQVE0125CA</b>	<b>P-AQVE0140CA</b>
Cooling capacity <sup>1)</sup>	kW		83,5	93,6	103,0	110,1	121,9	136,6
Input power <sup>1)</sup>	kW		26,9	31,0	33,5	36,5	41,1	46,1
EER <sup>1)</sup>			3,10	3,03	3,06	3,03	2,98	2,97
EER HSE <sup>1)</sup>			3,19	3,10	3,13	3,09	3,05	3,04
<b>SEER <sup>2)3)</sup></b>			<b>4,55</b>	<b>4,8</b>	<b>4,78</b>	<b>4,8</b>	<b>4,73</b>	<b>4,53</b>
<b><math>\eta_{s,c}</math> <sup>2)3)</sup></b>			<b>179</b>	<b>189</b>	<b>188</b>	<b>189</b>	<b>186</b>	<b>178</b>
<b>SEER HSE <sup>2)3)</sup></b>			<b>4,73</b>	<b>4,75</b>	<b>4,95</b>	<b>4,95</b>	<b>4,78</b>	<b>4,6</b>
<b><math>\eta_{s,c}</math> HSE <sup>2)3)</sup></b>			<b>186</b>	<b>187</b>	<b>195</b>	<b>195</b>	<b>188</b>	<b>181</b>
Nominal water flow (in the evaporator)	m <sup>3</sup> /h		14,3	16,1	17,6	19,0	21,0	23,5
Sound power <sup>4)</sup>	dB(A)		84	84	84	84	88	88
Sound pressure at 10 m <sup>5)</sup>	dB(A)		52	52	52	52	56	56
Sound power HPF <sup>4)</sup>	dB(A)		92	92	92	92	95	95
Sound pressure at 10 m HPF <sup>5)</sup>	dB(A)		60	60	60	60	63	63
<b>ECOi-W AQV 85-140 C S - chiller</b>			<b>85</b>	<b>95</b>	<b>105</b>	<b>115</b>	<b>125</b>	<b>140</b>
Cooling capacity <sup>1)</sup>	kW		80,6	90,2	98,6	106	119,1	133,1
Input power <sup>1)</sup>	kW		28	32,6	35,5	38,6	41,1	46,5
EER <sup>1)</sup>			2,87	2,76	2,77	2,73	2,90	2,86
EER HSE <sup>1)</sup>			3,00	2,87	2,87	2,81	2,96	2,91
<b>SEER <sup>2)3)</sup></b>			<b>4,75</b>	<b>4,78</b>	<b>4,98</b>	<b>5,0</b>	<b>4,8</b>	<b>4,6</b>
<b><math>\eta_{s,c}</math> <sup>2)3)</sup></b>			<b>187</b>	<b>188</b>	<b>196</b>	<b>197</b>	<b>189</b>	<b>181</b>
<b>SEER HSE <sup>2)3)</sup></b>			<b>4,8</b>	<b>4,75</b>	<b>4,88</b>	<b>4,88</b>	<b>4,9</b>	<b>4,7</b>
<b><math>\eta_{s,c}</math> HSE <sup>2)3)</sup></b>			<b>189</b>	<b>187</b>	<b>192</b>	<b>192</b>	<b>193</b>	<b>185</b>
Nominal water flow (in the evaporator)	m <sup>3</sup> /h		13,9	15,5	16,9	18,2	20,5	22,9
Sound power <sup>4)</sup>	dB(A)		82	82	82	82	86	86
Sound pressure at 10 m <sup>5)</sup>	dB(A)		50	50	50	50	54	54
<b>ECOi-W AQV 85-140 C HT - chiller</b>			<b>85</b>	<b>95</b>	<b>105</b>	<b>115</b>	<b>125</b>	<b>140</b>
Cooling capacity <sup>1)</sup>	kW		86,2	96,9	107	115	124	139
Input power <sup>1)</sup>	kW		28,1	31,6	33,9	36,4	41,1	46
EER <sup>1)</sup>			3,07	3,06	3,15	3,16	3,03	3,03
<b>SEER <sup>2)3)</sup></b>			<b>4,73</b>	<b>4,75</b>	<b>4,95</b>	<b>4,95</b>	<b>4,78</b>	<b>4,6</b>
<b><math>\eta_{s,c}</math> <sup>2)3)</sup></b>			<b>186</b>	<b>187</b>	<b>195</b>	<b>195</b>	<b>188</b>	<b>181</b>
Nominal water flow (in the evaporator)	m <sup>3</sup> /h		14,8	16,6	18,3	19,8	21,4	24,0
Sound power <sup>4)</sup>	dB(A)		95	95	95	95	95	95
Sound pressure at 10 m <sup>5)</sup>	dB(A)		63	63	63	63	63	63

1) According EN14511-2013: chilled water inlet/outlet temperature: 12/7 °C, outdoor ambient temperature 35 °C DB. 2) ErP compliant: following COMMISSION REGULATION (EU) 2016/2281. 3) According EN14825. 4) Sound levels are at fully loaded conditions. Sound power values refers to ISO 3744 standard. 5) Sound pressures refer to ISO 3744 standard, parallelepiped shape.

## Accessories and options

Anti-vibration spring dampers  
Automatic circuit breaker  
Coils treatments  
Desuperheater  
Fan speed control  
Hydrokit with 1 or 2 pumps with or without buffer tank  
Mechanical gauges  
Overload protection for compressors

## Accessories and options

Power factor corrector capacitors  
Several communication protocols  
Soft starter  
Unit protection grilles  
Water differential pressure  
Water filter  
Water pressure switch





## Technical performance

Power supply	Voltage	V	400	400	400	400	400	400
	Phase		Three phase	Three phase	Three phase	Three phase	Three phase	Three phase
	Frequency	Hz	50	50	50	50	50	50
Size			85	95	105	115	125	140
<b>ECOi-W AQV 85-140 H - heat pump</b>			<b>P-AQVE0085HA</b>	<b>P-AQVE0095HA</b>	<b>P-AQVE0105HA</b>	<b>P-AQVE0115HA</b>	<b>P-AQVE0125HA</b>	<b>P-AQVE0140HA</b>
Cooling capacity <sup>1)</sup>	kW	81	89,9	98,9	106,9	115,8	129,2	
Input power <sup>1)</sup>	kW	27,5	31,5	34,2	36,9	41,8	46,5	
EER <sup>1)</sup>		2,95	2,85	2,89	2,89	2,77	2,78	
EER HSE <sup>1)</sup>		3,05	2,94	2,97	2,96	2,84	2,84	
<b>SEER <sup>2)</sup></b>		<b>4,25</b>	<b>4,68</b>	<b>4,63</b>	<b>4,17</b>	<b>4,33</b>	<b>4,28</b>	
$\eta_{s,c}$ <sup>2)</sup>		<b>167</b>	<b>184</b>	<b>182</b>	<b>164</b>	<b>170</b>	<b>168</b>	
<b>SEER HSE <sup>2)</sup></b>		<b>4,6</b>	<b>5,03</b>	<b>4,95</b>	<b>4,55</b>	<b>4,6</b>	<b>4,5</b>	
$\eta_{s,c}$ HSE <sup>2)</sup>		<b>181</b>	<b>198</b>	<b>195</b>	<b>179</b>	<b>181</b>	<b>177</b>	
Nominal water flow (in the evaporator)	m <sup>3</sup> /h	13,9	15,5	17,0	18,4	19,9	22,2	
Heating capacity <sup>3)</sup>	kW	91,8	102,8	110	119	134	146,9	
Input power <sup>3)</sup>	kW	26,8	30,5	32,2	35,2	40,9	44,8	
COP <sup>3)</sup>		3,42	3,37	3,42	3,38	3,28	3,28	
COP HSE <sup>3)</sup>		3,54	3,47	3,52	3,47	3,36	3,36	
COP <sup>4)</sup>		4,35	4,28	4,36	4,32	4,16	4,17	
COP HSE <sup>4)</sup>		4,53	4,44	4,52	4,46	4,29	4,28	
<b>SCOP <sup>2) 5)</sup></b>		<b>3,61</b>	<b>3,64</b>	<b>3,78</b>	<b>3,77</b>	<b>3,47</b>	<b>3,54</b>	
$\eta_{s,h}$ <sup>2) 5)</sup>		<b>141</b>	<b>143</b>	<b>148</b>	<b>148</b>	<b>136</b>	<b>139</b>	
Nominal water flow (in the evaporator)	m <sup>3</sup> /h	17,2	17,8	19,3	20,6	23,3	25,5	
Sound power <sup>6)</sup>	dB(A)	84	84	84	84	88	88	
Sound pressure at 10 m <sup>7)</sup>	dB(A)	52	52	52	52	56	56	
Sound power HPF <sup>6)</sup>	dB(A)	92	92	92	92	95	95	
Sound pressure at 10 m HPF <sup>7)</sup>	dB(A)	60	60	60	60	63	63	
<b>ECOi-W AQV 85-140 H S - heat pump</b>			<b>85</b>	<b>95</b>	<b>105</b>	<b>115</b>	<b>125</b>	<b>140</b>
Cooling capacity <sup>1)</sup>	kW	78,4	86,7	95,1	102	112	124,6	
Input power <sup>1)</sup>	kW	28,6	33,2	36,0	39,1	43,1	47,6	
EER <sup>1)</sup>		2,75	2,61	2,64	2,62	2,61	2,63	
EER HSE <sup>1)</sup>		2,84	2,69	2,71	2,69	2,65	2,67	
<b>SEER <sup>2)</sup></b>		<b>4,25</b>	<b>4,68</b>	<b>4,63</b>	<b>4,17</b>	<b>4,33</b>	<b>4,28</b>	
$\eta_{s,c}$ <sup>2)</sup>		<b>167</b>	<b>184</b>	<b>182</b>	<b>164</b>	<b>170</b>	<b>168</b>	
<b>SEER HSE <sup>2)</sup></b>		<b>4,6</b>	<b>5,03</b>	<b>4,95</b>	<b>4,55</b>	<b>4,6</b>	<b>4,5</b>	
$\eta_{s,c}$ HSE <sup>2)</sup>		<b>181</b>	<b>198</b>	<b>195</b>	<b>179</b>	<b>181</b>	<b>177</b>	
Nominal water flow (in the evaporator)	m <sup>3</sup> /h	13,5	14,9	16,3	17,6	19,3	21,5	
Heating capacity <sup>3)</sup>	kW	89,5	99,8	108	115	129	142	
Input power <sup>3)</sup>	kW	26,4	30,1	32,0	34,7	39,3	43,0	
COP <sup>3)</sup>		3,39	3,32	3,36	3,32	3,29	3,30	
COP HSE <sup>3)</sup>		3,55	3,46	3,50	3,45	3,38	3,38	
COP <sup>4)</sup>		4,32	4,24	4,31	4,25	4,22	4,24	
COP HSE <sup>4)</sup>		4,58	4,46	4,51	4,44	4,34	4,35	
<b>SCOP <sup>2) 5)</sup></b>		<b>3,61</b>	<b>3,64</b>	<b>3,78</b>	<b>3,77</b>	<b>3,47</b>	<b>3,54</b>	
$\eta_{s,h}$ <sup>2) 5)</sup>		<b>141</b>	<b>143</b>	<b>148</b>	<b>148</b>	<b>136</b>	<b>139</b>	
Nominal water flow (in the evaporator)	m <sup>3</sup> /h	15,6	17,4	18,8	20,1	22,5	24,7	
Sound power <sup>6)</sup>	dB(A)	82	82	82	82	86	86	
Sound pressure at 10 m <sup>7)</sup>	dB(A)	50	50	50	50	54	54	
<b>ECOi-W AQV 85-140 H HT - heat pump</b>			<b>85</b>	<b>95</b>	<b>105</b>	<b>115</b>	<b>125</b>	<b>140</b>
Cooling capacity <sup>1)</sup>	kW	83,5	93,4	104	112	118	132	
Input power <sup>1)</sup>	kW	28,4	32,0	34,4	37	42	46,2	
EER <sup>1)</sup>		2,94	2,9	3,02	3,02	2,8	2,85	
<b>SEER <sup>2)</sup></b>		<b>4,6</b>	<b>5,02</b>	<b>4,95</b>	<b>4,55</b>	<b>4,6</b>	<b>4,5</b>	
$\eta_{s,c}$ <sup>2)</sup>		<b>181</b>	<b>198</b>	<b>195</b>	<b>179</b>	<b>181</b>	<b>177</b>	
Nominal water flow (in the evaporator)	m <sup>3</sup> /h	14,3	16,0	17,8	19,2	20,3	22,7	
Heating capacity <sup>3)</sup>	kW	93,4	104,9	113,7	121,9	135	148	
Input power <sup>3)</sup>	kW	29,4	33,1	35,0	37,8	42,2	46,1	
COP <sup>3)</sup>		3,18	3,17	3,25	3,23	3,21	3,21	
COP <sup>4)</sup>		3,98	3,98	4,08	4,07	4,06	4,08	
<b>SCOP <sup>2) 5)</sup></b>		<b>3,99</b>	<b>3,96</b>	<b>4,12</b>	<b>4,07</b>	<b>3,73</b>	<b>3,77</b>	
$\eta_{s,h}$ <sup>2) 5)</sup>		<b>157</b>	<b>155</b>	<b>162</b>	<b>160</b>	<b>146</b>	<b>148</b>	
Nominal water flow (in the evaporator)	m <sup>3</sup> /h	16,3	18,3	19,8	21,2	23,6	25,8	
Sound power <sup>6)</sup>	dB(A)	95	95	95	95	95	95	
Sound pressure at 10 m <sup>7)</sup>	dB(A)	63	63	63	63	63	63	

1) According EN14511-2013: chilled water inlet/outlet temperature: 12/7 °C, outdoor ambient temperature 35 °C DB. 2) According EN14825. 3) According EN14511-2013: warm water inlet/outlet temperature: 40/45 °C, outdoor ambient temperature 7 °C DB/6 °C WB. 4) According EN14511-2013: warm water inlet/outlet temperature: 30/35 °C, outdoor ambient temperature 7 °C DB/6 °C WB. 5) ErP compliant: following COMMISSION REGULATION (EU) No 813/2013. 6) Sound levels are at fully loaded conditions. Sound power values refers to ISO 3744 standard. 7) Sound pressures refer to ISO 3744 standard, parallelepiped shape.



Technical performance

	Voltage	V	400	400	400	400	400	400
Power supply	Phase		Three phase	Three phase	Three phase	Three phase	Three phase	Three phase
	Frequency	Hz	50	50	50	50	50	50
<b>Size</b>			<b>85</b>	<b>95</b>	<b>105</b>	<b>115</b>	<b>125</b>	<b>140</b>
<b>ECOi-W AQV 85-140 E STD / HSE / HPF - condensing unit</b>			<b>P-AQVE0085EA</b>	<b>P-AQVE0095EA</b>	<b>P-AQVE0105EA</b>	<b>P-AQVE0115EA</b>	<b>P-AQVE0125EA</b>	<b>P-AQVE0140EA</b>
Cooling capacity <sup>1)</sup>	kW		92,1	103,2	113,2	121,8	134,7	151,0
Input power <sup>1)</sup>	kW		27,4	31,4	34,1	37,0	41,7	46,8
Sound power <sup>2)</sup>	dB(A)		84	84	84	84	88	88
Sound pressure at 10 m <sup>3)</sup>	dB(A)		53	53	53	53	57	57
<b>ECOi-W AQV 85-140 E STD / HSE S - condensing unit</b>			<b>85</b>	<b>95</b>	<b>105</b>	<b>115</b>	<b>125</b>	<b>140</b>
Cooling capacity <sup>1)</sup>	kW		89	99,5	108,7	116,6	131,6	147,2
Input power <sup>1)</sup>	kW		28,6	33,1	36,1	39,3	41,9	47,3
Sound power <sup>2)</sup>	dB(A)		82	82	82	82	86	86
Sound pressure at 10 m <sup>3)</sup>	dB(A)		51	51	51	51	55	55
<b>ECOi-W AQV 85-140 E HT - condensing unit</b>			<b>85</b>	<b>95</b>	<b>105</b>	<b>115</b>	<b>125</b>	<b>140</b>
Cooling capacity <sup>1)</sup>	kW		95	106,8	117,7	127	137,2	153,8
Input power <sup>1)</sup>	kW		28,5	32,1	34,4	36,9	41,8	46,7
Sound power <sup>2)</sup>	dB(A)		95	95	95	95	95	95
Sound pressure at 10 m <sup>3)</sup>	dB(A)		64	64	64	64	64	64

Physical features

<b>ECOi-W AQV 85-140 C/H/E - chiller / heat pump / condensing unit</b>			<b>85</b>	<b>95</b>	<b>105</b>	<b>115</b>	<b>125</b>	<b>140</b>
Dimension	HxWxL	mm	2185 x 1095 x 2555	2185 x 1095 x 2555	2185 x 1095 x 2555	2185 x 1095 x 2555	2185 x 1095 x 3155	2185 x 1095 x 3155
Operating weight (C type)	STD / HT / S	kg	1058 / 1058 / 1088	1072 / 1072 / 1102	1111 / 1111 / 1141	1143 / 1143 / 1173	1183 / 1183 / 1213	1262 / 1262 / 1292
Operating weight (H type)	STD / HT / S	kg	1090 / 1090 / 1120	1105 / 1105 / 1135	1149 / 1149 / 1179	1180 / 1180 / 1210	1227 / 1227 / 1257	1301 / 1301 / 1331
Shipping weight (E type)	STD / S	kg	971 / 1001	983 / 1013	1013 / 1043	1043 / 1073	1066 / 1096	1142 / 1172
<b>Water connections (85-140 C/H types)</b>								
Type of water connections (evaporator)			Male gas threaded	Male gas threaded	Male gas threaded	Male gas threaded	Male gas threaded	Male gas threaded
Water inlet/outlet diameter			Inch 2 1/2	Inch 2 1/2	Inch 2 1/2	Inch 2 1/2	Inch 2 1/2	Inch 2 1/2
<b>Condenser (85-140 E type)</b>								
Connection type			To be brazed	To be brazed	To be brazed	To be brazed	To be brazed	To be brazed
Inlet diameter			Inch 5/8	Inch 5/8	Inch 5/8	Inch 5/8	Inch 7/8	Inch 7/8
Outlet diameter			Inch 1 3/8	Inch 1 3/8	Inch 1 3/8	Inch 1 3/8	Inch 1 3/8	Inch 1 3/8

1) Data refers to 7 °C leaving chilled water temperature and 35 °C condenser air temperature, according EN14511-2013 standard. 2) Sound levels are at fully loaded conditions. Sound power values refers to ISO 3744 standard. 3) Sound pressures refer to ISO 3744 standard, parallelepiped shape.



Special Inverter fan.  
Option.

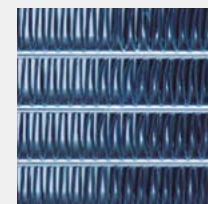

Bluefin coil.  
As standard on H models.

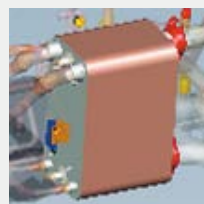

True dual circuit evaporator.  
Optimised heat transfer coefficient.

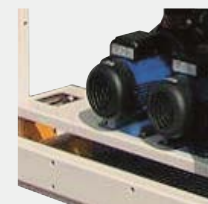

3 pump option.  
Energy saving in partial load.



# ECOi-W VL H/E · R410A

Air cooled heat pumps and condensing units.

Cooling capacity: 176,2 to 307 kW.

Heating capacity: 200 to 337,4 kW.



## Operating limits

To be confirmed with AC SELECT:

<https://acselect.panasonic.eu/>

ECOi-W VL 604-904 H - heat pump			704	804	904	
Cooling	Water outlet temperature	Water	°C	From 6 to 15		
		Water with glycol	°C	From 0 to 15		
		Water with glycol (Brine version)	°C	From -8 to 15		
		ΔT	K	From 3 to 8		
	Outdoor air temperature	STD	°C	-5 to 47	0 to 46	0 to 47
		L	°C	-5 to 45	0 to 44	0 to 45
S		°C	-18 to 41	-18 to 40	-18 to 41	
	HT	°C	-18 to 49	-18 to 48	-18 to 49	
ECOi-W VL 1004-1204 H - heat pump			1004	1104	1204	
Cooling	Water outlet temperature	Water	°C	From 6 to 15		
		Water with glycol	°C	From 0 to 15		
		Water with glycol (Brine version)	°C	From -8 to 15		
		ΔT	K	From 3 to 8		
	Outdoor air temperature	STD	°C	0 to 46	0 to 45	0 to 45
		L	°C	0 to 44	0 to 42	0 to 42
S		°C	-18 to 40	-18 to 38	-18 to 38	
	HT	°C	-18 to 48	-18 to 47	-18 to 47	
ECOi-W VL 604-1204 H - heat pump						
Heating	Water outlet temperature	°C	From 30 to 50 <sup>1)</sup>			
	Outdoor air temperature	STD	°C	From -10 to 20 <sup>1)</sup>		
		L / S	°C	From -4 to 20 <sup>1)</sup>		
External static pressure	STD fans	Pa	0			
	Inverter HPF	Pa	<120			
ECOi-W VL 604-904 E - condensing unit			704	804	904	
Outdoor air temperature	Evaporating temperature	°C	From 1 to 15			
	STD	°C	-18 to 47 <sup>1)</sup>	-18 to 46 <sup>1)</sup>	-18 to 46 <sup>2)</sup>	
		°C	-18 to 45 <sup>1)</sup>	-18 to 44 <sup>1)</sup>	-18 to 45 <sup>2)</sup>	
		°C	-18 to 49 <sup>1)</sup>	-18 to 48 <sup>1)</sup>	-18 to 49 <sup>2)</sup>	
ECOi-W VL 604-904 E - condensing unit			1004	1104	1204	
Outdoor air temperature	Evaporating temperature	°C	1 to 15			
	STD	°C	-18 to 46 <sup>2)</sup>	-18 to 45 <sup>2)</sup>	-18 to 45 <sup>2)</sup>	
		°C	-18 to 44 <sup>2)</sup>	-18 to 42 <sup>2)</sup>	-18 to 42 <sup>2)</sup>	
		°C	-18 to 48 <sup>2)</sup>	-18 to 47 <sup>2)</sup>	-18 to 47 <sup>2)</sup>	

<sup>1)</sup> Maximum water outlet temperature 50 °C (minimum temperature outdoor air +0 °C) to be confirmed with AC SELECT selection software. <sup>2)</sup> At high pressure 40,5 bar. Chillers suitable for operation without buffer tank for water content greater than 3 liters of water per kW of output.

## The range at a glance

- 2 versions: H (heat pump) and E (condensing unit)
- 6 sizes
- 3 configurations: STD (standard), HT (high temperature) and HPF (high pressure fan)
- 2 fan types: AC (standard fan) and EC (HSE model: high seasonal efficiency)
- 3 acoustic options: STD (standard), L (low noise) and S (super low noise)

## Advantages

- High seasonal performances: SCOP up to 3,4
- Small footprint
- Common configuration for the different versions: easy upgrade of the units in stock or on field
- Electronic expansion device: excellent control of superheating for the best performance at full and partial load and for a safe operation
- Compressor box: remarkable sound reduction even for the basic noise version
- Control platform: modular architecture, compressor envelope integration, corrective actions in border line areas, easy-friendly user interface

## Equipment

- 2 refrigerant circuits
- 4 scroll compressors (tandem)
- Plate evaporator (AISI 316)
- Microprocessor control
- Electronic expansion valve
- E-coating coil treatment
- Compressor acoustic box
- Phase sequence control
- Water differential pressure switch

## Accessories and options

Anti-vibration spring dampers
Automatic circuit breaker
Coils treatments
Compressor jackets (standard on S)
Desuperheater
Fan speed control (-18 °C)
Hydrokit with 1 or 2 pumps with or without buffer tank (500 l) (+1 m of length)
Inverter fans
Mechanical gauges
Overload protection for compressors
Power factor corrector capacitors
Several communication protocols
Soft starter
Unit protection grilles
Water filter
Water flow switch



Technical performance

Power supply	Voltage	V	400	400	400	400	400	400
	Phase		Three phase	Three phase	Three phase	Three phase	Three phase	Three phase
	Frequency	Hz	50	50	50	50	50	50
Size			<b>704</b>	<b>804</b>	<b>904</b>	<b>1004</b>	<b>1104</b>	<b>1204</b>
<b>ECOi-W VL 704-1204 H STD / HPF - heat pump</b>			<b>P-VLE0704HA</b>	<b>P-VLE0804HA</b>	<b>P-VLE0904HA</b>	<b>P-VLE1004HA</b>	<b>P-VLE1104HA</b>	<b>P-VLE1204HA</b>
Cooling capacity <sup>1)</sup>	kW	173,2	197,1	226,4	246,3	273,1	299,9	
Input power <sup>1)</sup>	kW	65,9	72,2	82,4	86,8	99,8	114,0	
EER <sup>1)</sup>		2,62	2,73	2,74	2,84	2,74	2,63	
<b>SEER <sup>2)</sup></b>		<b>3,63</b>	<b>3,55</b>	<b>3,35</b>	<b>3,5</b>	<b>3,53</b>	<b>3,43</b>	
$\eta_{s,c}$ <sup>2)</sup>		<b>142</b>	<b>139</b>	<b>131</b>	<b>137</b>	<b>138</b>	<b>134</b>	
<b>SEER HSE <sup>2)</sup></b>		<b>3,95</b>	<b>3,83</b>	<b>3,65</b>	<b>3,8</b>	<b>3,78</b>	<b>3,68</b>	
$\eta_{s,c}$ HSE <sup>2)</sup>		<b>155</b>	<b>150</b>	<b>143</b>	<b>149</b>	<b>148</b>	<b>144</b>	
Nominal water flow (in the evaporator)	m <sup>3</sup> /h	29,9	33,9	38,8	42,4	47,0	51,6	
Heating capacity <sup>3)</sup>	kW	200,1	223,2	254,7	270,8	302,1	337,4	
Input power <sup>3)</sup>	kW	67,4	70,4	79,6	87,6	100,0	112,5	
COP <sup>3)</sup>		2,97	3,17	3,20	3,09	3,02	3,00	
COP <sup>4)</sup>		3,71	3,96	3,99	3,86	3,78	3,77	
<b>SCOP <sup>2) 5)</sup></b>		<b>3,41</b>	<b>3,42</b>	<b>3,28</b>	<b>3,39</b>	<b>3,30</b>	<b>3,19</b>	
$\eta_{s,h}$ <sup>2) 5)</sup>		<b>133</b>	<b>134</b>	<b>128</b>	<b>133</b>	<b>129</b>	<b>125</b>	
<b>SCOP HSE <sup>2) 5)</sup></b>		<b>3,44</b>	<b>3,4</b>	<b>3,32</b>	<b>3,33</b>	<b>3,37</b>	<b>3,3</b>	
Nominal water flow (in the evaporator)	m <sup>3</sup> /h	34,7	38,6	43,6	47,0	52,3	58,4	
Sound power <sup>6)</sup>	dB(A)	93	93	94	94	95	95	
Sound pressure at 10 m <sup>7)</sup>	dB(A)	61	61	62	62	63	63	
<b>ECOi-W VL 704-1204 H L - heat pump</b>			<b>704</b>	<b>804</b>	<b>904</b>	<b>1004</b>	<b>1104</b>	<b>1204</b>
Cooling capacity <sup>1)</sup>	kW	168,2	191,2	220,4	237,3	261,2	285,1	
Input power <sup>1)</sup>	kW	66,2	73,3	83,8	88,5	102,8	119,8	
EER <sup>1)</sup>		2,54	2,61	2,63	2,68	2,54	2,38	
<b>SEER <sup>2)</sup></b>		<b>3</b>	<b>3</b>	<b>3,1</b>	<b>3,28</b>	<b>3,3</b>	<b>3,23</b>	
$\eta_{s,c}$ <sup>2)</sup>		<b>117</b>	<b>117</b>	<b>121</b>	<b>128</b>	<b>129</b>	<b>126</b>	
<b>SEER HSE <sup>2)</sup></b>		<b>3,95</b>	<b>3,83</b>	<b>3,65</b>	<b>3,80</b>	<b>3,78</b>	<b>3,68</b>	
$\eta_{s,c}$ HSE <sup>2)</sup>		<b>155</b>	<b>150</b>	<b>143</b>	<b>149</b>	<b>148</b>	<b>144</b>	
Nominal water flow (in the evaporator)	m <sup>3</sup> /h	29,0	32,9	38,2	40,8	45,0	49,1	
Heating capacity <sup>3)</sup>	kW	195,0	217,1	247,7	261,8	288,9	322,2	
Input power <sup>3)</sup>	kW	65,2	68,3	76,9	84,7	97,0	109,2	
COP <sup>3)</sup>		2,99	3,18	3,22	3,09	2,98	2,95	
COP <sup>4)</sup>		3,77	4,01	4,06	3,9	3,76	3,72	
<b>SCOP <sup>2) 5)</sup></b>		<b>3,41</b>	<b>3,42</b>	<b>3,28</b>	<b>3,39</b>	<b>3,20</b>	<b>3,19</b>	
$\eta_{s,h}$ <sup>2) 5)</sup>		<b>133</b>	<b>134</b>	<b>128</b>	<b>133</b>	<b>125</b>	<b>125</b>	
<b>SCOP HSE <sup>2) 5)</sup></b>		<b>3,44</b>	<b>3,4</b>	<b>3,32</b>	<b>3,33</b>	<b>3,37</b>	<b>3,24</b>	
Nominal water flow (in the evaporator)	m <sup>3</sup> /h	33,8	37,5	42,5	45,4	50,0	55,8	
Sound power <sup>6)</sup>	dB(A)	87	87	88	88	89	89	
Sound pressure at 10 m <sup>7)</sup>	dB(A)	55	55	56	56	57	57	
<b>ECOi-W VL 704-1204 H S - heat pump</b>			<b>704</b>	<b>804</b>	<b>904</b>	<b>1004</b>	<b>1104</b>	<b>1204</b>
Cooling capacity <sup>1)</sup>	kW	164,3	185,2	214,5	230,4	253,3	276,1	
Input power <sup>1)</sup>	kW	69,0	76,2	86,1	90,7	106,9	124,9	
EER <sup>1)</sup>		2,38	2,43	2,49	2,54	2,37	2,21	
<b>SEER <sup>2)</sup></b>		<b>3,63</b>	<b>3,55</b>	<b>3,35</b>	<b>3,5</b>	<b>3,53</b>	<b>3,43</b>	
$\eta_{s,c}$ <sup>2)</sup>		<b>142</b>	<b>139</b>	<b>131</b>	<b>137</b>	<b>138</b>	<b>134</b>	
<b>SEER HSE <sup>2)</sup></b>		<b>3,95</b>	<b>3,83</b>	<b>3,65</b>	<b>3,8</b>	<b>3,78</b>	<b>3,68</b>	
$\eta_{s,c}$ HSE <sup>2)</sup>		<b>155</b>	<b>150</b>	<b>143</b>	<b>149</b>	<b>148</b>	<b>144</b>	
Nominal water flow (in the evaporator)	m <sup>3</sup> /h	28,3	31,9	36,9	39,7	43,6	47,5	
Heating capacity <sup>3)</sup>	kW	184,9	202,9	232,6	245,7	266,8	297,0	
Input power <sup>3)</sup>	kW	64,9	67,0	75,8	83,9	95,0	108,0	
COP <sup>3)</sup>		2,85	3,03	3,07	2,93	2,81	2,75	
COP HSE <sup>3)</sup>		2,95	3,13	3,19	3,04	2,90	2,83	
COP <sup>4)</sup>		3,6	3,83	3,88	3,71	3,56	3,48	
COP HSE <sup>4)</sup>		3,76	3,98	4,07	3,87	3,7	3,59	
<b>SCOP <sup>2) 5)</sup></b>		<b>3,41</b>	<b>3,42</b>	<b>3,28</b>	<b>3,39</b>	<b>3,30</b>	<b>3,19</b>	
$\eta_{s,h}$ <sup>2) 5)</sup>		<b>133</b>	<b>134</b>	<b>128</b>	<b>133</b>	<b>129</b>	<b>125</b>	
<b>SCOP HSE <sup>2) 5)</sup></b>		<b>3,44</b>	<b>3,4</b>	<b>3,32</b>	<b>3,33</b>	<b>3,37</b>	<b>3,26</b>	
Nominal water flow (in the evaporator)	m <sup>3</sup> /h	32,0	35,2	40,4	42,5	46,3	51,5	
Sound power <sup>6)</sup>	dB(A)	83	83	84	84	85	85	
Sound pressure at 10 m <sup>7)</sup>	dB(A)	51	51	52	52	53	53	

1) According EN14511-2013: chilled water inlet/outlet temperature: 12/7 °C, outdoor ambient temperature 35 °C DB. 2) According EN14825. 3) According EN14511-2013: warm water inlet/outlet temperature: 40/45 °C, outdoor ambient temperature 7 °C DB/6 °C WB. 4) According EN14511-2013: warm water inlet/outlet temperature: 30/35 °C, outdoor ambient temperature 7 °C DB/6 °C WB. 5) ErP compliant: following COMMISSION REGULATION (EU) No 813/2013. 6) Sound levels are at fully loaded conditions. Sound power values refers to ISO 3744 standard. 7) Sound pressures refer to ISO 3744 standard, parallelepiped shape.





## Technical performance

	Voltage	V	400	400	400	400	400	400
Power supply	Phase		Three phase	Three phase	Three phase	Three phase	Three phase	Three phase
	Frequency	Hz	50	50	50	50	50	50
	<b>ECOi-W VL 704-1204 H HT - heat pump</b>			<b>704</b>	<b>804</b>	<b>904</b>	<b>1004</b>	<b>1104</b>
Cooling capacity <sup>1)</sup>	kW		175,6	199,7	229,5	250,1	276,5	305,6
Input power <sup>1)</sup>	kW		66,3	72,4	83,6	87,4	101,1	114,2
EER <sup>1)</sup>			2,64	2,75	2,74	2,85	2,73	2,67
<b>SEER <sup>2)</sup></b>			<b>3</b>	<b>3</b>	<b>3,1</b>	<b>3,28</b>	<b>3,3</b>	<b>3,23</b>
$\eta_{sc}$ <sup>2)</sup>			<b>117</b>	<b>117</b>	<b>121</b>	<b>128</b>	<b>129</b>	<b>126</b>
Nominal water flow (in the evaporator)	m <sup>3</sup> /h		30,1	34,3	39,4	42,9	47,5	52,5
Heating capacity <sup>3)</sup>	kW		200,7	224,0	256,6	273,7	305,5	341,5
Input power <sup>3)</sup>	kW		68,6	71,7	81,8	90,2	103	115
COP <sup>3)</sup>			2,93	3,13	3,14	3,04	2,98	2,97
COP <sup>4)</sup>			3,66	3,92	3,91	3,79	3,73	3,73
<b>SCOP <sup>2) 5)</sup></b>			<b>3,44</b>	<b>3,40</b>	<b>3,32</b>	<b>3,33</b>	<b>3,37</b>	<b>3,26</b>
$\eta_{s,h}$ <sup>2) 5)</sup>			<b>135</b>	<b>133</b>	<b>130</b>	<b>130</b>	<b>132</b>	<b>127</b>
Nominal water flow (in the evaporator)	m <sup>3</sup> /h		34,9	39,0	44,7	47,6	53,2	59,4
Sound power <sup>6)</sup>	dB(A)		99	99	100	100	100	100
Sound pressure at 10 m <sup>7)</sup>	dB(A)		67	67	68	68	68	68
<b>Size</b>			<b>704</b>	<b>804</b>	<b>904</b>	<b>1004</b>	<b>1104</b>	<b>1204</b>
<b>ECOi-W VL 704-1204 E STD / HPF - condensing unit</b>			<b>P-VLE0704EA</b>	<b>P-VLE0804EA</b>	<b>P-VLE0904EA</b>	<b>P-VLE1004EA</b>	<b>P-VLE1104EA</b>	<b>P-VLE1204EA</b>
Cooling capacity <sup>8)</sup>	kW		199,0	224,0	258,0	283,0	315,0	347,0
Input power <sup>8)</sup>	kW		68,7	74,7	86,6	90,6	106	120
Sound power <sup>6)</sup>	dB(A)		93	93	94	94	95	95
Sound pressure at 10 m <sup>7)</sup>	dB(A)		61	61	62	62	63	63
<b>ECOi-W VL 704-1204 E L - condensing unit</b>			<b>704</b>	<b>804</b>	<b>904</b>	<b>1004</b>	<b>1104</b>	<b>1204</b>
Cooling capacity <sup>8)</sup>	kW		194,0	218,0	251,0	272,5	301,0	330,0
Input power <sup>8)</sup>	kW		69,6	76,6	87,8	92,8	109	126
Sound power <sup>6)</sup>	dB(A)		87	87	88	88	89	89
Sound pressure at 10 m <sup>7)</sup>	dB(A)		55	55	56	56	57	57
<b>ECOi-W VL 704-1204 E S - condensing unit</b>			<b>704</b>	<b>804</b>	<b>904</b>	<b>1004</b>	<b>1104</b>	<b>1204</b>
Cooling capacity <sup>8)</sup>	kW		188,5	211,0	244,0	264,5	292,0	319,0
Input power <sup>8)</sup>	kW		72,0	79,5	90,5	95,5	112	131
Sound power <sup>6)</sup>	dB(A)		83	83	84	84	85	85
Sound pressure at 10 m <sup>7)</sup>	dB(A)		51	51	52	52	53	53
<b>ECOi-W VL 704-1204 E HT - condensing unit</b>			<b>704</b>	<b>804</b>	<b>904</b>	<b>1004</b>	<b>1104</b>	<b>1204</b>
Cooling capacity <sup>8)</sup>	kW		201,0	226,5	261,0	286,5	318,0	353,0
Input power <sup>8)</sup>	kW		68,9	74,9	87,1	91,0	105	119
Sound power <sup>6)</sup>	dB(A)		99	99	100	100	100	100
Sound pressure at 10 m <sup>7)</sup>	dB(A)		67	67	68	68	68	68

1) According EN14511-2013: chilled water inlet/outlet temperature: 12/7 °C, outdoor ambient temperature 35 °C DB. 2) According EN14825. 3) According EN14511-2013: warm water inlet/outlet temperature: 40/45 °C, outdoor ambient temperature 7 °C DB/6 °C WB. 4) According EN14511-2013: warm water inlet/outlet temperature: 30/35 °C, outdoor ambient temperature 7 °C DB/6 °C WB. 5) ErP compliant: following COMMISSION REGULATION (EU) No 813/2013. 6) Sound levels are at fully loaded conditions. Sound power values refers to ISO 3744 standard. 7) Sound pressures refer to ISO 3744 standard, parallelepiped shape. 8) Data refers to 7 °C leaving chilled water temperature and 35 °C condenser air temperature.

**Physical features**

<b>ECOi-W VL 704 - 1204 H/E - heat pump / condensing unit</b>			<b>704</b>	<b>804</b>	<b>904</b>	<b>1004</b>	<b>1104</b>	<b>1204</b>
Dimension	HxWxL	mm	2300 x 1100 x 4300	2300 x 1100 x 4300	2300 x 1100 x 4300	2300 x 1100 x 4300	2300 x 1100 x 4300	2300 x 1100 x 4300
Operating weight - heat pump	STD / L	kg	1675	1820	1980	2125	2215	2225
	S	kg	1710	1855	2015	2165	2255	2265
	HT	kg	1705	1850	2020	2165	2255	2265
Shipping weight - condensing unit	STD / L	kg	1490	1615	1700	1825	1910	1920
	S	kg	1525	1650	1735	1865	1950	1960
	HT	kg	1520	1645	1740	1865	1950	1960
<b>ECOi-W VL 704-1204 H STD / HPF - heat pump</b>			<b>704</b>	<b>804</b>	<b>904</b>	<b>1004</b>	<b>1104</b>	<b>1204</b>
<b>Water connections</b>								
Type of water connections (evaporator)			Male gas threaded	Male gas threaded	Male gas threaded	Male gas threaded	Male gas threaded	Male gas threaded
Water inlet/outlet diameter		Inch	2 1/2	2 1/2	3	3	3	3
<b>ECOi-W VL 704-1204 E - condensing unit</b>			<b>704</b>	<b>804</b>	<b>904</b>	<b>1004</b>	<b>1104</b>	<b>1204</b>
<b>Refrigerant connections</b>								
Inlet diameter		Inch	7/8	7/8	1 1/8	1 1/8	1 1/8	1 1/8
Outlet diameter		Inch	1 5/8	1 5/8	2 1/8	2 1/8	2 1/8	2 1/8



# ECOi-W AQUA EVO 230-360 C/H/E · R410A

Air cooled chillers, heat pumps and condensing units.

**Cooling capacity: 231 to 360,7 kW.**

**Heating capacity: 229 to 361,4 kW.**



## Operating limits

To be confirmed with AC SELECT:

<https://acselect.panasonic.eu/>

ECOi-W AQUA EVO 230-360 C - chiller				
Chilled liquid	Liquid outlet temperature	Water	°C	From 5 to 18
		Water with glycol*	°C	From -10 to 5
		Temperature spread	K	From 3 to 7
Maximum operating pressure		bar	6	
Outdoor air temperature	Air entering temperature cooling	STD	°C	From 5 to 48
		L	°C	From 0 to 46
		S	°C	From -14 to 44
		EC-HT	°C	From -18 to 50
External static pressure	STD fans	Pa	0	
	High pressure fan (HPF)	Pa	<120	
ECOi-W AQUA EVO 230-360 H - heat pump				
Chilled liquid	Liquid outlet temperature	Water	°C	From 5 to 18
		Water with glycol*	°C	From -10 to 5
		ΔT	K	From 3 to 7
Outdoor air temperature	Air entering temperature cooling	STD / L / S	°C	5 to 48 / 0 to 46 / -14 to 44
		EC-HT	°C	From -18 to 50
Warm liquid	Liquid outlet temperature	Water	°C	From 20 to 55
		ΔT	K	From 3 to 7
Outdoor air temperature	Air entering temperature heating	STD / L / S / EC	°C	From -10 to 20
		Polar Version	°C	From -13 to 20
		HT	°C	From -13 to 20
External static pressure	STD fans	Pa	0	
	High pressure fan (HPF)	Pa	<120	
ECOi-W AQUA EVO 230-360 E - condensing unit				
Evaporating temperature		°C	From 1 to 15	
Outdoor air temperature		STD	°C	From 5 to 48
		L	°C	From -14 to 46
		S	°C	From -14 to 44
		EC-HT	°C	From -18 to 50

\* For Liquid outlet temperature <0 °C provide Brine Version (available for C; upon request for H).

## The range at a glance

- 3 versions: C (chiller), H (heat pump) and E (condensing unit)
- 6 sizes
- 3 configurations: STD (standard), HT (high temperature) and HPF (high pressure fan)
- 2 fan types: AC (standard fan) and EC (high efficiency fan)
- 3 acoustic options: STD (standard), L (low noise) and S (super low noise)

## Advantages

- High seasonal performances: SEER up to 4,3
- Common configuration for the different versions: easy upgrade of the units in stock or on field
- Electronic expansion device: excellent control of superheating for the best performance at full and partial load and for a safe operation
- Microchannel coils: significant reduction on refrigerant charge and operating weight
- Compressor box: remarkable sound reduction even for the basic noise version
- Control platform: modular architecture, compressor envelope integration, corrective actions in border line areas, easy-friendly user interface

## Equipment

- 2 refrigerant circuits
- 4 scroll compressors (tandem)
- Electronic expansion valve
- Microchannel coils (C type)
- E-coating coil treatment
- Brine version: chiller for process application LWT -10 °C (C type)
- Polar version: heat pump for extreme conditions (H type)
- Plate heat exchanger evaporator
- Compressor acoustic box
- Compressor jackets (standard as super low noise)
- Fan speed control (standard as super low noise)
- Phase sequence control
- Water differential pressure switch



Technical performance

Power supply <sup>1)</sup>	Voltage	V	400	400	400	400	400	400
	Phase		Three phase	Three phase	Three phase	Three phase	Three phase	Three phase
	Frequency	Hz	50	50	50	50	50	50
Size			230	260	280	300	330	360
<b>ECOi-W AQUA EVO 230-360 C - chiller</b>			<b>P-AQAVE0230CA</b>	<b>P-AQAVE0260CA</b>	<b>P-AQAVE0280CA</b>	<b>P-AQAVE0300CA</b>	<b>P-AQAVE0330CA</b>	<b>P-AQAVE0360CA</b>
Nominal cooling capacity <sup>2)</sup>	kW		231	263	284	310	331	362
Input power <sup>2)</sup>	kW		74,8	84,6	91,3	99,0	104,7	116,8
EER <sup>2)</sup> / EER*			3,1 / 3,1	3,1 / 3,2	3,1 / 3,2	3,1 / 3,2	3,2 / 3,2	3,1 / 3,2
<b>SEER <sup>3) 4)</sup></b>			<b>4,25</b>	<b>4,25</b>	<b>4,23</b>	<b>4,18</b>	<b>4,20</b>	<b>4,10</b>
<b>n<sub>s,c</sub> <sup>3) 4)</sup></b>			<b>167</b>	<b>167</b>	<b>166</b>	<b>164</b>	<b>165</b>	<b>161</b>
Nominal water flow (in the evaporator)	m <sup>3</sup> /h		39,6	45,2	48,8	53,2	56,9	62,1
Sound power <sup>5)</sup>	dB(A)		92	93	93	94	95	95
Sound pressure 10 m <sup>6)</sup>	dB(A)		60	61	61	62	63	63
<b>ECOi-W AQUA EVO 230-360 C L - chiller</b>			<b>230</b>	<b>260</b>	<b>280</b>	<b>300</b>	<b>330</b>	<b>360</b>
Nominal cooling capacity <sup>2)</sup>	kW		224	256	276	301	322	351
Input power <sup>2)</sup>	kW		74,4	84,5	92,0	99,7	104,9	117,8
EER <sup>2)</sup> / EER*			3 / 3,02	3,0 / 3,1	3,0 / 3,0	3,0 / 3,1	3,1 / 3,1	3 / 3,03
<b>SEER <sup>3) 4)</sup></b>			<b>4,28</b>	<b>4,28</b>	<b>4,25</b>	<b>4,25</b>	<b>4,25</b>	<b>4,10</b>
<b>n<sub>s,c</sub> <sup>3) 4)</sup></b>			<b>168</b>	<b>168</b>	<b>167</b>	<b>167</b>	<b>167</b>	<b>161</b>
Nominal water flow (in the evaporator)	m <sup>3</sup> /h		38,4	43,9	47,4	51,7	55,3	60,2
Sound power <sup>5)</sup>	dB(A)		87	88	88	89	90	90
Sound pressure 10 m <sup>6)</sup>	dB(A)		55	56	56	57	58	58
<b>ECOi-W AQUA EVO 230-360 C S - chiller</b>			<b>230</b>	<b>260</b>	<b>280</b>	<b>300</b>	<b>330</b>	<b>360</b>
Nominal cooling capacity <sup>2)</sup>	kW		210	242	259	283	305	329
Input power <sup>2)</sup>	kW		79,2	88,6	97,4	105,6	109,7	123,7
EER <sup>2)</sup> / EER*			2,7 / 2,7	2,7 / 2,8	2,7 / 2,7	2,7 / 2,7	2,8 / 2,8	2,7 / 2,7
<b>SEER <sup>3) 4)</sup></b>			<b>4,1</b>	<b>4,15</b>	<b>4,1</b>	<b>4,1</b>	<b>4,1</b>	<b>4,1</b>
<b>n<sub>s,c</sub> <sup>3) 4)</sup></b>			<b>161</b>	<b>163</b>	<b>161</b>	<b>161</b>	<b>161</b>	<b>161</b>
Nominal water flow (in the evaporator)	m <sup>3</sup> /h		36,1	41,5	44,6	48,6	52,4	56,6
Sound power <sup>5)</sup>	dB(A)		82	83	83	85	86	86
Sound pressure 10 m <sup>6)</sup>	dB(A)		50	51	51	53	54	54
<b>ECOi-W AQUA EVO 230-360 C HT - chiller</b>			<b>230</b>	<b>260</b>	<b>280</b>	<b>300</b>	<b>330</b>	<b>360</b>
Nominal cooling capacity <sup>2)</sup>	kW		232	265	286	312	333	364
Input power <sup>2)</sup>	kW		77,6	87,9	94,7	103,7	109,9	121,7
EER <sup>2)</sup>			2,99	3,01	3,02	3,01	3,03	2,99
<b>SEER <sup>3) 4)</sup></b>			<b>4,63</b>	<b>4,65</b>	<b>4,63</b>	<b>4,68</b>	<b>4,65</b>	<b>4,43</b>
<b>n<sub>s,c</sub> <sup>3) 4)</sup></b>			<b>182</b>	<b>183</b>	<b>182</b>	<b>184</b>	<b>183</b>	<b>174</b>
Nominal water flow (in the evaporator)	m <sup>3</sup> /h		40,0	45,6	49,3	53,7	57,3	62,7
Sound power <sup>5)</sup>	dB(A)		94	96	96	97	98	98
Sound pressure 10 m <sup>6)</sup>	dB(A)		62	64	64	65	66	66

1) Voltage 400 V +/- 10%. 2) According EN14511-2013: chilled water inlet/outlet temperature: 12/7 °C, outdoor ambient temperature 35 °C DB. 3) ErP compliant: following COMMISSION REGULATION (EU) 2016/2281. 4) According EN14825. 5) Sound levels are at fully loaded conditions. Sound power values refers to ISO 3744 standard. 6) Sound pressures refer to ISO 3744 standard, parallelepiped shape.

Accessories and options

- Anti-vibration spring dampers
- Automatic circuit breaker
- Coils treatments
- Desuperheater
- Fan speed control [-14 °C in cooling mode – standard as super low noise version]
- Hydrokit with 1 or 2 pumps with or without buffer tank (500 l)
- Mechanical gauges
- Overload protection for compressors

Accessories and options

- Power factor corrector capacitors
- Several communication protocols
- Soft starter
- SRC - mini BMS controller
- Unit protection grilles
- Variable pump
- Water filter
- Water flow switch





## Technical performance

Power supply <sup>1)</sup>	Voltage	V	400	400	400	400	400	400
	Phase		Three phase	Three phase	Three phase	Three phase	Three phase	Three phase
	Frequency	Hz	50	50	50	50	50	50
Size			<b>230</b>	<b>260</b>	<b>280</b>	<b>300</b>	<b>330</b>	<b>360</b>
ECOi-W AQUA EVO 230-360 H - heat pump			P-AQAVE0230HA	P-AQAVE0260HA	P-AQAVE0280HA	P-AQAVE0300HA	P-AQAVE0330HA	P-AQAVE0360HA
Nominal cooling capacity <sup>2)</sup>	kW		214	244	261	288	307	341
Input power <sup>2)</sup>	kW		73,2	83,8	90,7	98,5	103,5	117,0
EER <sup>2)</sup>			2,92	2,91	2,88	2,92	2,97	2,91
EER* / EER**			2,96 / 2,75	2,95 / 2,73	2,91 / 2,71	2,96 / 2,75	3,02 / 2,78	2,95 / 2,74
SEER / $\eta_{s,c}$ <sup>3)</sup>			<b>4,13 / 162</b>	<b>4,05 / 159</b>	<b>4,1 / 161</b>	<b>3,83 / 150</b>	<b>3,8 / 149</b>	<b>3,93 / 154</b>
SEER* / SEER** <sup>3)</sup>			<b>4,22</b>	<b>4,13</b>	<b>4,2</b>	<b>3,93</b>	<b>3,8</b>	<b>4,05</b>
$\eta_{s,c}$ * / $\eta_{s,c}$ ** <sup>3)</sup>			<b>166</b>	<b>162</b>	<b>165</b>	<b>154</b>	<b>149</b>	<b>159</b>
Nominal water flow (in the evaporator)	m <sup>3</sup> /h		36,8	42,0	45,0	49,5	52,9	58,6
Nominal heating capacity <sup>4) 5)</sup>	40-45 °C / 30-35 °C	kW	229 / 234	262 / 269	280 / 286	306 / 311	327 / 334	361 / 368
Input power <sup>4) 5)</sup>	40-45 °C / 30-35 °C	kW	70,9 / 58,7	81,7 / 67,8	87,4 / 72,3	94,9 / 77,8	101,9 / 83,7	112,6 / 92,7
COP <sup>4) 5)</sup>	40-45 °C / 30-35 °C		3,23 / 3,98	3,21 / 3,96	3,20 / 3,95	3,22 / 4,00	3,21 / 3,99	3,21 / 3,97
COP* / COP**			3,27 / 3,03	3,26 / 3,01	3,25 / 3,02	3,27 / 3,02	3,26 / 2,99	3,26 / 3,02
SCOP <sup>3) 6)</sup>			<b>3,46</b>	<b>3,48</b>	<b>3,44</b>	<b>3,51</b>	<b>3,44</b>	<b>3,48</b>
$\eta_{s,h}$ <sup>3) 6)</sup>			<b>135</b>	<b>136</b>	<b>135</b>	<b>137</b>	<b>135</b>	<b>136</b>
Nominal water flow (in the evaporator)	m <sup>3</sup> /h		39,7	45,5	48,5	53,0	56,8	62,7
Sound power <sup>7)</sup>	dB(A)		92	93	93	94	95	95
Sound pressure at 10 m <sup>8)</sup>	dB(A)		60	61	61	62	63	63
ECOi-W AQUA EVO 230-360 H L - heat pump			<b>230</b>	<b>260</b>	<b>280</b>	<b>300</b>	<b>330</b>	<b>360</b>
Nominal cooling capacity <sup>2)</sup>	kW		207	237	253	279	299	330
Input power <sup>2)</sup>	kW		73,7	83,7	91,4	99,1	103,1	117,5
EER <sup>2)</sup> / EER*			2,81 / 2,85	2,83 / 2,87	2,77 / 2,81	2,82 / 2,86	2,90 / 2,94	2,81 / 2,84
SEER / $\eta_{s,c}$ <sup>3)</sup>			<b>4,13 / 162</b>	<b>4,05 / 159</b>	<b>4,1 / 161</b>	<b>3,83 / 150</b>	<b>3,8 / 149</b>	<b>3,93 / 154</b>
SEER* / $\eta_{s,c}$ * <sup>3)</sup>			<b>3,7 / 145</b>	<b>3,65 / 143</b>	<b>3,63 / 142</b>	<b>2,58 / 100</b>	<b>2,65 / 103</b>	<b>4,17 / 164</b>
Nominal water flow (in the evaporator)	m <sup>3</sup> /h		35,7	40,8	43,6	48,1	51,5	56,8
Nominal heating capacity <sup>4) 5)</sup>	40-45 °C / 30-35 °C	kW	224 / 228	256 / 261	272 / 277	299 / 304	321 / 326	354 / 359
Input power <sup>4) 5)</sup>	40-45 °C / 30-35 °C	kW	69,0 / 56,5	79,4 / 65,2	84,8 / 69,8	92,7 / 75,2	99,6 / 81,0	109,9 / 89,8
COP <sup>4) 5)</sup>	40-45 °C / 30-35 °C		3,24 / 4,03	3,22 / 4,00	3,21 / 3,97	3,23 / 4,04	3,22 / 4,03	3,22 / 4,00
COP* <sup>4)</sup>			3,32	3,31	3,29	3,31	3,31	3,30
SCOP <sup>3) 6)</sup>			<b>3,46</b>	<b>3,48</b>	<b>3,44</b>	<b>3,51</b>	<b>3,44</b>	<b>3,48</b>
$\eta_{s,h}$ <sup>3) 6)</sup>			<b>135</b>	<b>136</b>	<b>135</b>	<b>137</b>	<b>135</b>	<b>136</b>
Nominal water flow (in the evaporator)	m <sup>3</sup> /h		38,8	44,3	47,2	52,0	55,7	61,4
Sound power <sup>7)</sup>	dB(A)		87	88	88	89	90	90
Sound pressure at 10 m <sup>8)</sup>	dB(A)		55	56	56	57	58	58
ECOi-W AQUA EVO 230-360 H S - heat pump			<b>230</b>	<b>260</b>	<b>280</b>	<b>300</b>	<b>330</b>	<b>360</b>
Nominal cooling capacity <sup>2)</sup>	kW		194	224	239	263	284	311
Input power <sup>2)</sup>	kW		77,6	88,2	96,6	104,5	108,2	124,2
EER <sup>2)</sup> / EER*			2,51 / 2,54	2,54 / 2,58	2,47 / 2,50	2,52 / 2,55	2,62 / 2,66	2,50 / 2,53
SEER / $\eta_{s,c}$ <sup>3)</sup>			<b>4,13 / 162</b>	<b>4,05 / 159</b>	<b>3,60 / 141</b>	<b>3,83 / 150</b>	<b>3,8 / 149</b>	<b>3,93 / 154</b>
SEER* / $\eta_{s,c}$ * <sup>3)</sup>			<b>3,7 / 145</b>	<b>3,65 / 143</b>	<b>3,63 / 142</b>	<b>2,58 / 100</b>	<b>2,65 / 103</b>	<b>4,17 / 164</b>
Nominal water flow (in the evaporator)	m <sup>3</sup> /h		33,5	38,6	41,1	45,3	48,8	53,5
Nominal heating capacity <sup>4) 5)</sup>	40-45 °C / 30-35 °C	kW	220 / 223	251 / 255	267 / 271	295 / 298	315 / 320	349 / 353
Input power <sup>4) 5)</sup>	40-45 °C / 30-35 °C	kW	67,2 / 55,1	77,2 / 63,5	82,4 / 67,8	90,4 / 73,5	96,9 / 78,9	107,4 / 87,6
COP <sup>4) 5)</sup>	40-45 °C / 30-35 °C		3,27 / 4,05	3,25 / 4,02	3,24 / 4,00	3,26 / 4,06	3,25 / 4,05	3,25 / 4,03
SCOP <sup>3) 6)</sup>			<b>3,46</b>	<b>3,48</b>	<b>3,44</b>	<b>3,51</b>	<b>3,44</b>	<b>3,48</b>
$\eta_{s,h}$ <sup>3) 6)</sup>			<b>135</b>	<b>136</b>	<b>135</b>	<b>137</b>	<b>135</b>	<b>136</b>
Nominal water flow (in the evaporator)	m <sup>3</sup> /h		38,1	43,5	46,3	51,2	54,7	60,5
Sound power <sup>7)</sup>	dB(A)		82	83	83	85	86	86
Sound pressure at 10 m <sup>8)</sup>	dB(A)		50	51	51	53	54	54
ECOi-W AQUA EVO 230-360 H HT - heat pump			<b>230</b>	<b>260</b>	<b>280</b>	<b>300</b>	<b>330</b>	<b>360</b>
Nominal cooling capacity <sup>2)</sup>	kW		216	246	263	290	310	343
Input power <sup>2)</sup>	kW		77,0	88,4	95,1	103,7	109,9	123,1
EER <sup>2)</sup>			2,80	2,78	2,77	2,80	2,82	2,79
SEER / $\eta_{s,c}$ <sup>3)</sup>			<b>3,8 / 149</b>	<b>3,73 / 146</b>	<b>3,78 / 148</b>	<b>4,28 / 168</b>	<b>3,95 / 155</b>	<b>4,08 / 160</b>
Nominal water flow (in the evaporator)	m <sup>3</sup> /h		37,1	42,3	45,4	50,0	53,3	59,1
Nominal heating capacity <sup>4)</sup>	kW		232	266	284	310	332	367
Input power <sup>4)</sup>	kW		75,7	87,2	92,7	101,2	109,0	119,8
COP <sup>4)</sup>			3,07 / 3,76	3,05 / 3,73	3,06 / 3,73	3,06 / 3,76	3,04 / 3,73	3,06 / 3,74
SCOP <sup>3) 6)</sup>			<b>3,56</b>	<b>3,57</b>	<b>3,53</b>	<b>3,61</b>	<b>3,55</b>	<b>3,58</b>
$\eta_{s,h}$ <sup>3) 6)</sup>			<b>139</b>	<b>140</b>	<b>138</b>	<b>141</b>	<b>139</b>	<b>140</b>
Nominal water flow (in the evaporator)	m <sup>3</sup> /h		40,3	46,1	49,2	53,8	57,5	63,6
Sound power <sup>7)</sup>	dB(A)		94	96	96	97	98	98
Sound pressure at 10 m <sup>8)</sup>	dB(A)		62	64	64	65	66	66

1) Voltage 400 V +/- 10%. 2) According EN14511-2013: chilled water inlet/outlet temperature: 12/7 °C, outdoor ambient temperature 35 °C DB. 3) According EN14825. 4) According EN14511-2013: warm water inlet/outlet temperature: 40/45 °C, outdoor ambient temperature 7 °C DB/6 °C WB. 5) According EN14511-2013: warm water inlet/outlet temperature: 30/35 °C, outdoor ambient temperature 7 °C DB/6 °C WB. 6) ErP compliant: following COMMISSION REGULATION (EU) No 813/2013. 7) Sound levels are at fully loaded conditions. Sound power values refers to ISO 3744 standard. 8) Sound pressures refer to ISO 3744 standard, parallelepiped shape.

\* High efficiency units (EC) with Inverter fans. \*\* H type units with high static pressure fans.



Technical performance

	Voltage	V	400	400	400	400	400	400
Power supply	Phase		Three phase	Three phase	Three phase	Three phase	Three phase	Three phase
	Frequency	Hz	50	50	50	50	50	50
<b>Size</b>			<b>230</b>	<b>260</b>	<b>280</b>	<b>300</b>	<b>330</b>	<b>360</b>
<b>ECOi-W AQUA EVO 230-360 E - condensing unit</b>			<b>P-AQAVE0230EA</b>	<b>P-AQAVE0260EA</b>	<b>P-AQAVE0280EA</b>	<b>P-AQAVE0300EA</b>	<b>P-AQAVE0330EA</b>	<b>P-AQAVE0360EA</b>
Nominal cooling capacity <sup>1)</sup>	kW		250	288	313	337	361	395
Input power <sup>1)</sup>	kW		74,6	84,4	91,6	99,4	105	117
Sound power <sup>2)</sup>	dB(A)		92	93	93	94	95	95
Sound pressure at 10 m <sup>3)</sup>	dB(A)		60	61	61	62	63	63
<b>ECOi-W AQUA EVO 230-360 E L - condensing unit</b>			<b>230</b>	<b>260</b>	<b>280</b>	<b>300</b>	<b>330</b>	<b>360</b>
Nominal cooling capacity <sup>1)</sup>	kW		242	279	302	326	351	381
Input power <sup>1)</sup>	kW		75,4	84,8	92,6	100	105	118
Sound power <sup>2)</sup>	dB(A)		87	88	88	89	90	90
Sound pressure at 10 m <sup>3)</sup>	dB(A)		55	56	56	57	58	58
<b>ECOi-W AQUA EVO 230-360 E S - condensing unit</b>			<b>230</b>	<b>260</b>	<b>280</b>	<b>300</b>	<b>330</b>	<b>360</b>
Nominal cooling capacity <sup>1)</sup>	kW		225	262	281	305	330	356
Input power <sup>1)</sup>	kW		80,1	89,6	98,4	107	111	126
Sound power <sup>2)</sup>	dB(A)		82	83	83	85	86	86
Sound pressure at 10 m <sup>3)</sup>	dB(A)		50	51	51	53	54	54
<b>ECOi-W AQUA EVO 230-360 E HT - condensing unit</b>			<b>230</b>	<b>260</b>	<b>280</b>	<b>300</b>	<b>330</b>	<b>360</b>
Nominal cooling capacity <sup>1)</sup>	kW		253	291	316	341	364	398
Input power <sup>1)</sup>	kW		78,2	88,9	95,8	105	111	123
Sound power <sup>2)</sup>	dB(A)		94	96	96	97	98	98
Sound pressure at 10 m <sup>3)</sup>	dB(A)		62	64	64	65	66	66

Physical features

<b>ECOi-W AQUA EVO 230-360 C/H - chiller / heat pump</b>			<b>230</b>	<b>260</b>	<b>280</b>	<b>300</b>	<b>330</b>	<b>360</b>
Dimension	HxWxL	mm	2500 x 2150 x 3500	2500 x 2150 x 3500	2500 x 2150 x 3500	2500 x 2150 x 4550	2500 x 2150 x 4550	2500 x 2150 x 4550
Operating weight - chiller	STD / L	kg	1693	1890	1953	2227	2345	2519
	S	kg	1698	1895	1958	2232	2350	2524
	HT	kg	1743	1950	2013	2297	2425	2599
Operating weight - heat pump	STD / L	kg	2078	2343	2458	2702	2887	3063
	S	kg	2083	2348	2463	2707	2892	3068
	HT	kg	2128	2403	2518	2772	2967	3143
<b>Water connections</b>								
Type of water connections (evaporator)			Male gas threaded	Male gas threaded	Male gas threaded	Male gas threaded	Male gas threaded	Male gas threaded
Water inlet/outlet diameter	Inch		3	3	3	3	3	3
<b>ECOi-W AQUA EVO 230-360 E - condensing unit</b>			<b>230</b>	<b>260</b>	<b>280</b>	<b>300</b>	<b>330</b>	<b>360</b>
Dimension	HxWxL	mm	2500 x 2150 x 3500	2500 x 2150 x 3500	2500 x 2150 x 3500	2500 x 2150 x 4550	2500 x 2150 x 4550	2500 x 2150 x 4550
Shipping weight	kg		1542	1726	1788	1946	2061	2235
<b>Refrigerant connections</b>								
Connection type			To be brazed	To be brazed	To be brazed	To be brazed	To be brazed	To be brazed
Inlet diameter	Inch		1 5/8 - 2 1/8	1 5/8 - 2 1/8	1 5/8 - 2 1/8	2 1/8	2 1/8	2 1/8
Outlet diameter	Inch		7/8 - 1 1/8	7/8 - 1 1/8	7/8 - 1 1/8	1 1/8	1 1/8	1 1/8

1) Data refers to 7 °C leaving chilled water temperature and 35 °C condenser air temperature. 2) Sound levels are at fully loaded conditions. Sound power values refers to ISO 3744 standard. 3) Sound pressures refer to ISO 3744 standard, parallelepiped shape.



# ECOi-W AQUA EVO 400-800 C/H - R410A

Air cooled chillers and heat pumps.

Cooling capacity: 398,8 to 797,9 kW.

Heating capacity: 404 to 807,3 kW.



## Operating limits

To be confirmed with AC SELECT:

<https://acselect.panasonic.eu/>

ECOi-W AQUA EVO 400-800 C - chiller				
Chilled liquid	Liquid outlet temperature	Water	°C	From 5 to 18
		Water with glycol*	°C	From -10 to 5
		ΔT	K	From 3 to 7
	Maximum operating pressure	bar		6
Outdoor air temperature	Air entering temperature cooling	STD	°C	From 10 to 48
		S / EC / EC S	°C	From -18 to 48
		HT	°C	From -18 to 52
External static pressure	STD fans	Pa		0
	High pressure fan (HPF)	Pa		<120
ECOi-W AQUA EVO 400-800 H - heat pump				
Chilled liquid	Liquid outlet temperature	Water	°C	From 5 to 18
		Water with glycol	°C	From -3 to 5
		ΔT	K	From 3 to 7
Outdoor air temperature	Air entering temperature cooling	STD	°C	From 10 to 46
		S / EC / EC S	°C	From -18 to 46
Warm liquid	Liquid outlet temperature	Water	°C	From 25 to 55
		ΔT	K	From 3 to 7
Outdoor air temperature	Air entering temperature heating	STD	°C	From -10 to 20
		S / EC / EC S	°C	From -10 to 35
		HT	°C	From -13 to 35
External static pressure	STD fans	Pa		0
	High pressure fan (HPF)	Pa		<120

\* For liquid outlet temperature <-3 °C provide Brine version.

## The range at a glance

- 2 versions: C (chiller) and H (heat pump)
- 8 sizes (C type) / 9 sizes (H type)
- 3 configurations: STD (standard), HT (high temperature) and HPF (high pressure fan)
- 2 fan types: AC (standard fan) and EC (high efficiency fan)
- 2 acoustic options: STD (standard) and S (super low noise)

## Advantages

- High seasonal performances: SEER up to 4,6
- Low sound emission and high efficiency level in a single unit: Super Low Noise version
- Electronic expansion device: excellent control of superheating for the best performance at full and partial load and for a safe operation
- E-coated microchannel coils: Significant reduction on refrigerant charge and operating weight and excellent anticorrosion protection with the standard delivery
- Compressor box: remarkable sound reduction even for the basic noise version
- Control platform: modular architecture, compressor envelope integration, corrective actions in border line areas, easy-friendly user interface

## Equipment

- Brine version: chiller for process application LWT -10 °C
- Polar version: heat pump for extreme conditions
- Plate evaporator
- Electronic expansion valve
- Modbus RS485 (standard fro sizes 400-670)
- Microchannel coils
- E-coating coil treatment as standard
- Compressor acoustic box
- Compressor jackets (standard as super low noise)
- Fan speed control (standard as super low noise)
- Phase sequence control
- Water differential pressure switch

## AC SELECT.

Smart and user-friendly the new air conditioning selection program: <https://acselect.panasonic.eu/>





## Technical performance

Power supply <sup>1)</sup>	Voltage	V	400	400	400	400	400	400	400	400
	Phase		Three phase	Three phase	Three phase	Three phase	Three phase	Three phase	Three phase	Three phase
	Frequency	Hz	50	50	50	50	50	50	50	50
Size			<b>400</b>	<b>450</b>	<b>490</b>	<b>530</b>	<b>600</b>	<b>670</b>	<b>750</b>	<b>800</b>
<b>ECOi-W AQUA EVO 400-800 C - chiller</b>	<b>P-</b>	<b>AQAVE0400CA</b>	<b>AQAVE0450CA</b>	<b>AQAVE0490CA</b>	<b>AQAVE0530CA</b>	<b>AQAVE0600CA</b>	<b>AQAVE0670CA</b>	<b>AQAVE0750CA</b>	<b>AQAVE0800CA</b>	
Nominal cooling capacity <sup>2)</sup>	kW	398,8	446,1	487,7	533,9	597,1	667,3	748,3	797,9	
Input power <sup>2)</sup>	kW	128,6	142,8	157,1	172,1	192,1	215,0	241,7	257,4	
EER <sup>2)</sup>		3,10	3,12	3,10	3,10	3,11	3,10	3,10	3,10	
EER EC <sup>2)</sup>		3,18	3,21	3,19	3,18	3,19	3,18	3,17	3,17	
<b>SEER <sup>3)4)</sup></b>		<b>4,48</b>	<b>4,43</b>	<b>4,50</b>	<b>4,38</b>	<b>4,58</b>	<b>4,65</b>	<b>4,48</b>	<b>4,50</b>	
<b><math>\eta_{s,c}</math> <sup>3)4)</sup></b>		<b>176</b>	<b>174*</b>	<b>177*</b>	<b>172*</b>	<b>180</b>	<b>183</b>	<b>176*</b>	<b>177*</b>	
<b>SEER EC <sup>3)4)</sup></b>		<b>4,65</b>	<b>4,58</b>	<b>4,68</b>	<b>4,55</b>	<b>4,78</b>	<b>4,85</b>	<b>4,65</b>	<b>4,68</b>	
<b><math>\eta_{s,c} EC</math> <sup>3)4)</sup></b>		<b>183</b>	<b>180</b>	<b>184</b>	<b>179</b>	<b>188</b>	<b>191</b>	<b>183</b>	<b>184</b>	
Nominal water flow (in the evaporator)	m <sup>3</sup> /h	68,6	76,8	84,0	91,9	103	115	129	138	
Sound power <sup>5)</sup>	dB(A)	92	93	93	94	94	94	95	95	
Sound pressure at 10 m <sup>6)</sup>	dB(A)	60	61	60	61	61	61	62	62	
<b>ECOi-W AQUA EVO 400-800 C S - chiller</b>		<b>400</b>	<b>450</b>	<b>490</b>	<b>530</b>	<b>600</b>	<b>670</b>	<b>750</b>	<b>800</b>	
Nominal cooling capacity <sup>2)</sup>	kW	396,0	440,4	480,4	524,8	585,3	651,7	743,4	792,2	
Input power <sup>2)</sup>	kW	127,2	141,4	156,0	171,4	192,0	215,6	238,6	254,6	
EER <sup>2)</sup>		3,11	3,11	3,08	3,06	3,05	3,02	3,12	3,11	
EER EC <sup>2)</sup>		3,20	3,21	3,17	3,15	3,13	3,10	3,20	3,19	
<b>SEER <sup>3)4)</sup></b>		<b>4,50</b>	<b>4,63</b>	<b>4,58</b>	<b>4,78</b>	<b>4,80</b>	<b>4,73</b>	<b>4,73</b>	<b>4,70</b>	
<b><math>\eta_{s,c}</math> <sup>3)4)</sup></b>		<b>177</b>	<b>182</b>	<b>180</b>	<b>188</b>	<b>189</b>	<b>186</b>	<b>186</b>	<b>185</b>	
<b>SEER EC <sup>3)4)</sup></b>		<b>4,68</b>	<b>4,80</b>	<b>4,73</b>	<b>5,05</b>	<b>5,05</b>	<b>4,93</b>	<b>4,93</b>	<b>4,90</b>	
<b><math>\eta_{s,c} EC</math> <sup>3)4)</sup></b>		<b>184</b>	<b>189</b>	<b>186</b>	<b>199</b>	<b>199</b>	<b>194</b>	<b>194</b>	<b>193</b>	
Nominal water flow (in the evaporator)	m <sup>3</sup> /h	68,1	75,8	82,7	90,4	101	112	128	137	
Sound power <sup>5)</sup>	dB(A)	86	87	87	87	88	88	89	89	
Sound pressure at 10 m <sup>6)</sup>	dB(A)	54	54	54	54	55	55	56	56	
<b>ECOi-W AQUA EVO 400-800 C HT - chiller</b>		<b>400</b>	<b>450</b>	<b>490</b>	<b>530</b>	<b>600</b>	<b>670</b>	<b>750</b>	<b>800</b>	
Nominal cooling capacity <sup>2)</sup>	kW	411,2	455,8	497,3	543,1	607,2	678,7	768,3	820,5	
Input power <sup>2)</sup>	kW	123,4	138,4	152,2	167,3	186,4	208,9	234,2	249,2	
EER <sup>2)</sup>		3,33	3,29	3,27	3,25	3,26	3,25	3,28	3,29	
<b>SEER <sup>3)4)</sup></b>		<b>4,78</b>	<b>4,83</b>	<b>4,80</b>	<b>4,83</b>	<b>4,85</b>	<b>4,85</b>	<b>4,70</b>	<b>4,63</b>	
<b><math>\eta_{s,c}</math> <sup>3)4)</sup></b>		<b>188</b>	<b>190</b>	<b>189</b>	<b>190</b>	<b>191</b>	<b>191</b>	<b>185</b>	<b>182</b>	
Nominal water flow (in the evaporator)	m <sup>3</sup> /h	70,8	78,5	85,7	93,6	105	117	132	142	
Sound power <sup>5)</sup>	dB(A)	93	93	94	94	94	95	96	96	
Sound pressure at 10 m <sup>6)</sup>	dB(A)	60	61	60	61	61	61	62	62	

1) Voltage 400 V +/- 10%. 2) According EN14511-2013: chilled water inlet/outlet temperature: 12/7 °C, outdoor ambient temperature 35 °C DB. 3) ErP compliant: following COMMISSION REGULATION (EU) 2016/2281. 4) According EN14825. 5) Sound powers is declared in nominal full load condition (cooling operation), referring to ISO standard 9614, in accordance with Eurovent certification program. 6) Sound pressure refer to ISO Standard 3744, parallelepiped shape in a free field on a reflective surface.

\* Non ErP compliant: following COMMISSION REGULATION (EU) 2016/2281.

## Accessories and options

Anti-vibration spring dampers
Automatic circuit breaker
Coils treatments
Desuperheater
Fan speed control (-14 °C in cooling mode – standard as super low noise version)
Hydrokit with 1 or 2 pumps with or without buffer tank (500 l 400-450, 1000 l 470-670)
Mechanical gauges
Overload protection for compressors

## Accessories and options

Power factor corrector capacitors
Several communication protocols
Soft starter
SRC - mini BMS controller
Unit protection grilles
Variable pump (for sizes 750-800 upon request)
Water filter
Water flow switch



ErP: Check ErP compliance according to the configurations in AC SLECT: <https://acselect.panasonic.eu/>.





## Technical performance

Power supply <sup>1)</sup>	Voltage	V	400	400	400	400	400	400	400	400	400
	Phase		Three phase	Three phase	Three phase	Three phase	Three phase	Three phase	Three phase	Three phase	Three phase
	Frequency	Hz	50	50	50	50	50	50	50	50	50
Size			<b>400</b>	<b>450</b>	<b>490</b>	<b>530</b>	<b>580</b>	<b>620</b>	<b>670</b>	<b>750</b>	<b>800</b>
<b>ECOi-W AQUA EVO 400-800 H - heat pump P-</b>											
Nominal cooling capacity <sup>2)</sup>	kW		373,5	419,2	454,5	489,7	535,7	581,5	625,4	701,4	748,1
Input power <sup>2)</sup>	kW		132,3	147,8	160,9	173,0	190,2	206,1	221,5	247,4	263,8
EER <sup>2)</sup>			2,82	2,84	2,82	2,83	2,82	2,82	2,82	2,84	2,84
EER EC <sup>2)</sup>			2,90	2,91	2,90	2,90	2,90	2,90	2,90	2,91	2,91
<b>SEER <sup>3)</sup></b>			<b>4,65</b>	<b>4,53</b>	<b>4,7</b>	<b>4,55</b>	<b>4,33</b>	<b>4,35</b>	<b>4,3</b>	<b>4,3</b>	<b>4,35</b>
$\eta_{s,c}$ <sup>3)</sup>			<b>183</b>	<b>178</b>	<b>185</b>	<b>179</b>	<b>170*</b>	<b>171*</b>	<b>169*</b>	<b>169*</b>	<b>171*</b>
<b>SEER EC <sup>3)</sup></b>			<b>4,93</b>	<b>4,83</b>	<b>4,97</b>	<b>4,88</b>	<b>4,5</b>	<b>4,5</b>	<b>4,45</b>	<b>4,45</b>	<b>4,48</b>
$\eta_{s,c}$ EC <sup>3)</sup>			<b>194</b>	<b>190</b>	<b>196</b>	<b>192</b>	<b>177*</b>	<b>177*</b>	<b>175*</b>	<b>175*</b>	<b>176*</b>
Nominal water flow (in the evaporator)	m <sup>3</sup> /h		64,3	72,1	78,2	84,3	92,2	100	108	121	129
Nominal heating capacity <sup>4)</sup>	kW		404,0	450,9	492,7	532,1	585,8	627,7	677,8	758,3	807,3
Input power <sup>4)</sup>	kW		125,9	140,8	153,8	166,3	183,0	195,5	212,0	237,0	252,3
COP <sup>4)</sup>			3,21	3,20	3,20	3,20	3,20	3,21	3,20	3,20	3,20
COP <sup>5)</sup>			3,88	3,82	3,85	3,87	3,85	3,88	3,85	3,9	3,87
COP EC <sup>4)</sup>			3,30	3,29	3,29	3,29	3,29	3,31	3,29	3,29	3,29
COP EC <sup>5)</sup>			4,0	3,94	3,98	4,0	3,98	4,01	3,98	4,03	4,0
<b>SCOP <sup>3)</sup></b>			<b>3,46</b>	<b>3,47</b>	<b>3,37</b>	<b>3,38</b>	—	—	—	—	—
$\eta_{s,h}$ <sup>3)</sup>			<b>135</b>	<b>136</b>	<b>132</b>	<b>132</b>	—	—	—	—	—
<b>SCOP EC <sup>3)</sup></b>			<b>3,62</b>	<b>3,62</b>	<b>3,53</b>	<b>3,53</b>	—	—	—	—	—
$\eta_{s,h}$ EC <sup>3)</sup>			<b>142</b>	<b>142</b>	<b>138</b>	<b>138</b>	—	—	—	—	—
Nominal water flow (in the evaporator)	m <sup>3</sup> /h		70,1	78,3	85,5	92,3	102	109	118	131	140
Sound power <sup>6)</sup>	dB(A)		92	93	93	94	94	95	95	95	95
Sound pressure at 10 m <sup>7)</sup>	dB(A)		60	61	60	61	61	62	62	62	62
<b>ECOi-W AQUA EVO 400-800 H S - heat pump</b>											
Nominal cooling capacity <sup>2)</sup>	kW		371,2	417,3	453,4	487,3	531,4	578,6	621,5	701,5	743,2
Input power <sup>2)</sup>	kW		128,1	143,6	156,5	167,6	183,3	199,0	214,1	241,4	256,6
EER <sup>2)</sup>			2,90	2,91	2,90	2,91	2,90	2,91	2,90	2,91	2,90
EER EC <sup>2)</sup>			2,98	2,99	2,98	2,99	2,98	2,99	2,99	2,99	2,98
<b>SEER <sup>3)</sup></b>			<b>5,03</b>	<b>4,53</b>	<b>5,1</b>	<b>5,05</b>	<b>4,6</b>	<b>4,6</b>	<b>4,55</b>	<b>4,55</b>	<b>4,58</b>
$\eta_{s,c}$ <sup>3)</sup>			<b>198</b>	<b>178</b>	<b>201</b>	<b>199</b>	<b>181</b>	<b>181</b>	<b>179</b>	<b>179</b>	<b>180</b>
<b>SEER EC <sup>3)</sup></b>			<b>5,35</b>	<b>5,33</b>	<b>5,45</b>	<b>5,48</b>	<b>4,75</b>	<b>4,73</b>	<b>4,7</b>	<b>4,65</b>	<b>4,65</b>
$\eta_{s,c}$ EC <sup>3)</sup>			<b>211</b>	<b>210</b>	<b>215</b>	<b>216</b>	<b>187</b>	<b>186</b>	<b>185</b>	<b>183</b>	<b>183</b>
Nominal water flow (in the evaporator)	m <sup>3</sup> /h		63,9	71,8	78,0	83,9	91,5	99,6	107	121	128
Nominal heating capacity <sup>4)</sup>	kW		403,6	451,7	490,3	531,2	585,6	627,1	676,7	757,4	805,3
Input power <sup>4)</sup>	kW		124,3	138,2	152,2	165,9	182,9	193,2	209,6	234,0	247,7
COP <sup>4)</sup>			3,25	3,27	3,22	3,20	3,20	3,25	3,23	3,24	3,25
COP <sup>5)</sup>			4,01	3,97	3,97	3,98	3,96	4,01	3,97	4,04	4,01
COP EC <sup>4)</sup>			3,34	3,37	3,32	3,29	3,30	3,34	3,32	3,34	3,35
COP EC <sup>5)</sup>			4,16	4,11	4,11	4,12	4,11	4,16	4,11	4,19	4,15
<b>SCOP <sup>3)</sup></b>			<b>3,76</b>	<b>3,76</b>	<b>3,69</b>	<b>3,68</b>	—	—	—	—	—
$\eta_{s,h}$ <sup>3)</sup>			<b>147</b>	<b>147</b>	<b>145</b>	<b>144</b>	—	—	—	—	—
<b>SCOP EC <sup>3)</sup></b>			<b>3,99</b>	<b>3,98</b>	<b>3,91</b>	<b>3,89</b>	—	—	—	—	—
$\eta_{s,h}$ EC <sup>3)</sup>			<b>157</b>	<b>156</b>	<b>153</b>	<b>153</b>	—	—	—	—	—
Nominal water flow (in the evaporator)	m <sup>3</sup> /h		70,0	78,4	85,1	92,2	102	109	117	132	140
Sound power <sup>6)</sup>	dB(A)		86	87	87	87	88	88	88	89	89
Sound pressure at 10 m <sup>7)</sup>	dB(A)		53	54	54	54	55	55	55	56	56

1) Voltage 400 V +/- 10%. 2) According EN14511-2013: chilled water inlet/outlet temperature: 12/7 °C, outdoor ambient temperature 35 °C DB. 3) According EN14825. 4) According EN14511-2013: warm water inlet/outlet temperature: 40/45 °C, outdoor ambient temperature 7 °C DB/6 °C WB. 5) According EN14511-2013: warm water inlet/outlet temperature: 30/35 °C, outdoor ambient temperature 7 °C DB/6 °C WB. 6) Sound power is declared in nominal full load condition (cooling operation), referring to ISO standard 9614, in accordance with Eurovent certification program. 7) Sound pressure refer to ISO Standard 3744, parallelepiped shape in a free field on a reflective surface. 8) ErP compliant: following COMMISSION REGULATION (EU) 2016/2281. \* Non ErP compliant: following COMMISSION REGULATION (EU) 2016/2281.

**Physical features**

<b>ECOi-W AQUA EVO 400-800 C - chiller</b>			<b>400</b>	<b>450</b>	<b>490</b>	<b>530</b>	<b>600</b>	<b>670</b>	<b>750</b>	<b>800</b>	
Dimension	HxW	mm	2500 x 2175	2500 x 2175	2500 x 2175	2500 x 2175	2500 x 2175	2500 x 2175	2500 x 2175	2500 x 2175	
	Length STD / EC / HPF	mm	4580	5620	6680	6680	7760	7760	8900	8900	
	Length S / EC S / HT	mm	5620	6680	7760	7760	8800	8800	11000	11000	
Operating weight	STD / EC / HPF	kg	3028	3367	3783	4069	4317	4524	5536	5607	
	S / EC S / HT	kg	3318	3656	4069	4369	4597	4789	6111	6183	
<b>Water connections (evaporator and condenser)</b>											
Type of water connections			Victaulic®	Victaulic®	Victaulic®	Victaulic®	Victaulic®	Victaulic®	Victaulic®	Victaulic®	
Water inlet/outlet diameter			Inch	4	4	4	4	4	5	6	
<b>ECOi-W AQUA EVO 400-800 H - heat pump</b>			<b>400</b>	<b>450</b>	<b>490</b>	<b>530</b>	<b>580</b>	<b>620</b>	<b>670</b>	<b>750</b>	<b>800</b>
Dimension	HxW	mm	2500 x 2175	2500 x 2175	2500 x 2175	2500 x 2175	2500 x 2175	2500 x 2175	2500 x 2175	2500 x 2175	
	Length STD / EC / HPF	mm	5620	5620	6680	6680	7760	8800	8800	9950	9950
	Length S / EC S	mm	6680	6680	7760	7760	8800	9850	9850	12050	12050
Operating weight	STD / EC / HPF	kg	3769	3938	4412	4744	5214	5554	5691	6790	6985
	S / EC S	kg	4131	4293	4764	5101	5567	5919	6059	7497	7683
<b>Water connections (evaporator)</b>											
Type of water connections			Victaulic®	Victaulic®	Victaulic®	Victaulic®	Victaulic®	Victaulic®	Victaulic®	Victaulic®	
Water inlet/outlet diameter			Inch	4	4	4	4	4	5	6	



# ECOi-W SW-N EVO 380-1260 C - R513A

Air cooled chillers.

Cooling capacity: 366 to 1240,5 kW.



## Operating limits

To be confirmed with AC SELECT:  
<https://acselect.panasonic.eu/>

ECOi-W SW-N EVO 380-1260 C - chiller			
Leaving water temperature	Water	°C	From 5 to 15
	Water with glycol	°C	From 0 to 5
	Brine	°C	From -8 to 0
	ΔT	K	From 3 to 8
Outdoor air temperature	STD	°C	From -10 to 46
	S	°C	From -10 to 44
	HT	°C	From -10 to 49
	Minimum air temperature	°C	-10
External static pressure	STD fans	Pa	0
	High pressure fans	Pa	< 120

## Accessories and options

Antifreeze electric heater for hydraulic manifolds  
 Anti-vibration spring dampers  
 Chiller grilles  
 Compressor acoustic box  
 Compressor star delta start  
 Compressor suction valve  
 E-coating treatment  
 Finned tubes (Al/Cu)

## The range at a glance

- 1 version: C (chiller)
- 12 sizes
- 2 configurations: STD (standard) and HT (high temperature)
- 1 fan type: EC (high efficiency fan)
- 2 acoustic options: STD (standard) and S (super low noise)

## Advantages

- High seasonal efficiency level exceeding ErP 2021 requirements
- High durability painting process for casing and frame, offering C4 corrosion category in accordance with ISO 12944
- Compressor metal box, providing basic acoustic protection and resistance to atmospheric agents
- Side panel on coil ends, protecting from corrosion and damage
- EC fan motors, improving part load efficiency, extending envelope operation and reducing noise level in part load operation
- Proprietary software logic, optimizing unit efficiency in accordance with plant needs and protecting unit operation with preventing actions

## Equipment

- 2 refrigerant circuits
- 2 screw compressors
- Pure countercurrent shell and tubes direct expansion heat exchanger
- Axial type EC fan motors
- Micro-channels condensers
- Electronic expansion valve
- Hydronic / heat recovery options

## Accessories and options

Flow switch  
 Hydro kit 1P-SP/1P-HP/2P-SP/2PHP  
 Mechanical gauges kit (HP and LP manometers)  
 Power factor corrector capacitors  
 Several communication protocols  
 Variable pump  
 Water filter

## AC SELECT.

Smart and user-friendly the new air conditioning selection program: <https://acselect.panasonic.eu/>





Technical performance

	Voltage	V	400	400	400	400	400	400	400	400	400	400	400	400
Power supply	Phase		Three phase	Three phase	Three phase	Three phase	Three phase	Three phase	Three phase	Three phase	Three phase	Three phase	Three phase	Three phase
	Frequency	Hz	50	50	50	50	50	50	50	50	50	50	50	50
	<b>Size</b>		<b>380</b>	<b>440</b>	<b>510</b>	<b>590</b>	<b>660</b>	<b>730</b>	<b>810</b>	<b>900</b>	<b>980</b>	<b>1060</b>	<b>1160</b>	<b>1260</b>
<b>ECOi-W SW-N EVO 380-1260 C STD / HT / HP - chiller</b>	<b>P-SWVN****CA</b>		<b>0380</b>	<b>0440</b>	<b>0510</b>	<b>0590</b>	<b>0660</b>	<b>0730</b>	<b>0810</b>	<b>0900</b>	<b>0980</b>	<b>1060</b>	<b>1160</b>	<b>1260</b>
Nominal cooling capacity <sup>1)</sup>	kW		365,7	443,0	500,2	565,8	643,5	704,3	778,1	896,9	983,5	1047,4	1154,0	1240,5
Input power <sup>1)</sup>	kW		123,9	142,9	165,6	181,1	206,2	228,6	253,4	290,2	322,3	332,0	370,4	408,1
EER <sup>1)</sup>			2,95	3,10	3,02	3,12	3,12	3,08	3,07	3,09	3,05	3,15	3,12	3,04
EER <sub>CONDITION B</sub> [74%]			3,95	4,01	3,99	4,02	3,93	3,95	3,89	3,82	3,98	4,10	4,14	4,20
EER <sub>CONDITION C</sub> [47%]			4,66	4,81	4,81	5,03	4,76	4,66	4,72	4,68	4,72	5,10	5,06	5,02
EER <sub>CONDITION D</sub> [21%]			6,14	6,31	6,33	6,65	6,62	6,23	6,62	6,32	6,22	6,69	6,70	6,68
<b>SEER <sup>2)3)</sup></b>			<b>4,53</b>	<b>4,66</b>	<b>4,65</b>	<b>4,80</b>	<b>4,66</b>	<b>4,56</b>	<b>4,62</b>	<b>4,56</b>	<b>4,60</b>	<b>4,87</b>	<b>4,86</b>	<b>4,85</b>
$\eta_{s,c}$ <sup>2)3)</sup>	%		<b>178</b>	<b>183</b>	<b>183</b>	<b>189</b>	<b>183</b>	<b>179</b>	<b>182</b>	<b>179</b>	<b>181</b>	<b>192</b>	<b>191</b>	<b>191</b>
Number of refrigerant circuits			2	2	2	2	2	2	2	2	2	2	2	2
Total capacity steps <sup>4)</sup>	%		22% ÷ 100%	18% ÷ 100%	16% ÷ 100%	14% ÷ 100%	13% ÷ 100%	15% ÷ 100%	13% ÷ 100%	14% ÷ 100%	13% ÷ 100%	17% ÷ 100%	15% ÷ 100%	14% ÷ 100%
Sound power <sup>5)</sup>	dB(A)		97	98	100	100	100	101	101	102	102	103	103	103
Sound power <sup>5)**/***</sup>	dB(A)		102	103	104	104	104	105	105	106	106	107	108	108
Sound pressure at 10 m <sup>6)</sup>	dB(A)		65	66	68	68	68	68	68	69	69	70	70	70
Sound pressure at 10 m <sup>6)**/***</sup>	dB(A)		70	71	72	72	72	72	72	73	73	74	75	75
<b>ECOi-W SW-N EVO 380-1260 C S - chiller</b>			<b>380</b>	<b>440</b>	<b>510</b>	<b>590</b>	<b>660</b>	<b>730</b>	<b>810</b>	<b>900</b>	<b>980</b>	<b>1060</b>	<b>1160</b>	<b>1260</b>
Nominal cooling capacity <sup>1)</sup>	kW		362,8	441,8	498,2	563,1	640,0	702,5	775,9	893,1	980,9	1045,5	1150,6	1234,8
Input power <sup>1)</sup>	kW		126,1	144,9	168,0	184,0	209,3	231,5	256,4	294,7	326,4	335,5	375,0	416,8
EER <sup>1)</sup>			2,88	3,05	2,97	3,06	3,06	3,03	3,03	3,03	3,01	3,12	3,07	2,96
EER <sub>CONDITION B</sub> [74%]			3,90	4,03	3,99	4,00	3,96	3,97	4,01	3,84	4,18	4,15	4,22	4,31
EER <sub>CONDITION C</sub> [47%]			4,69	5,04	5,05	5,21	4,95	4,91	4,98	4,94	5,02	5,24	5,36	5,30
EER <sub>CONDITION D</sub> [21%]			6,44	6,82	6,75	6,92	6,93	6,64	6,71	6,60	6,55	7,00	7,24	7,04
<b>SEER <sup>2)3)</sup></b>			<b>4,56</b>	<b>4,82</b>	<b>4,79</b>	<b>4,89</b>	<b>4,78</b>	<b>4,73</b>	<b>4,77</b>	<b>4,69</b>	<b>4,82</b>	<b>4,98</b>	<b>5,07</b>	<b>5,03</b>
$\eta_{s,c}$ <sup>2)3)</sup>	%		<b>180</b>	<b>190</b>	<b>189</b>	<b>193</b>	<b>188</b>	<b>186</b>	<b>188</b>	<b>185</b>	<b>190</b>	<b>196</b>	<b>200</b>	<b>198</b>
Number of refrigerant circuits			2	2	2	2	2	2	2	2	2	2	2	2
Total capacity steps <sup>4)</sup>	%		22% ÷ 100%	18% ÷ 100%	16% ÷ 100%	14% ÷ 100%	13% ÷ 100%	15% ÷ 100%	13% ÷ 100%	14% ÷ 100%	13% ÷ 100%	17% ÷ 100%	15% ÷ 100%	14% ÷ 100%
Sound power <sup>5)</sup>	dB(A)		94	94	97	97	97	98	98	99	99	99	100	100
Sound pressure at 10 m <sup>6)</sup>	dB(A)		62	62	65	65	65	65	65	66	66	66	67	67

Physical features

<b>ECOi-W SW-N EVO 380-1260 C - chiller</b>		<b>380</b>	<b>440</b>	<b>510</b>	<b>590</b>	<b>660</b>	<b>730</b>	<b>810</b>	<b>900</b>	<b>980</b>	<b>1060</b>	<b>1160</b>	<b>1260</b>	
Dimension	Height	mm	2510	2510	2510	2510	2510	2510	2510	2510	2510	2510	2510	
	Height S	mm	2590	2590	2590	2590	2590	2590	2590	2590	2590	2590	2590	
	Width	mm	2192	2192	2192	2192	2192	2192	2192	2192	2192	2192	2192	
	Length	mm	4660	5712	5712	6764	7816	7816	8868	9920	10972	12024	13076	
Operating weight	STD / HT / HP	kg	3896	4259	4897	5241	5620	6207	6531	7326	7764	8491	8875	9074
	S	kg	3981	4352	4990	5323	5702	6293	6617	7412	7852	8579	8963	9162

1) Data refers to 7 °C leaving chilled water temperature and 35 °C condenser air temperature, according EN14511-2013 standard. 2) ErP compliant: following COMMISSION REGULATION (EU) 2016/2281. 3) According EN14825. 4) This value can change for BC version or other special applications. 5) Sound levels are at fully loaded conditions. Sound power values refer to ISO standard 3744. 6) Sound pressures refer to ISO Standard 3744, parallelepiped shape. \* High temperature units (HT), data with fans at maximum speed (1100 r.p.m.). \*\* HPF units, data with fans at maximum speed (1100 r.p.m.).

Technological innovation - All-round variable volume flow management.

Refrigerant.

Inverter driven compressor technology and electronic expansion valve.



Air.

EC brushless fan motor technology.



Water.

Inverter driven pump technology.

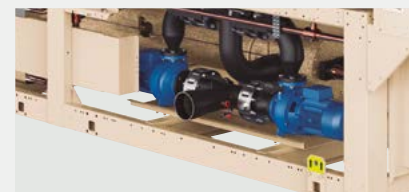

Improved part load efficiency.  
Continuous capacity control.  
Flexible offer in plant integration.



## Water cooled chillers, heat pumps and condenserless units

Quality and comfort for all your projects! Perfect for any type of building, the system consists of water cooled chillers or heat pumps that provide cold or hot water to water terminals. This system is particularly well suited for applications such as office buildings, hotels, shopping centers and hospitals.



Water cooled chillers use water as the cooling medium to extract heat from the cooling circuit by cooling and condensing the refrigerant.

**Advantages:**

- Higher cooling efficiency compared to air cooled chillers
- Less impact on the environment with less waste heat or fan noise

\* The below illustration show cooling application.

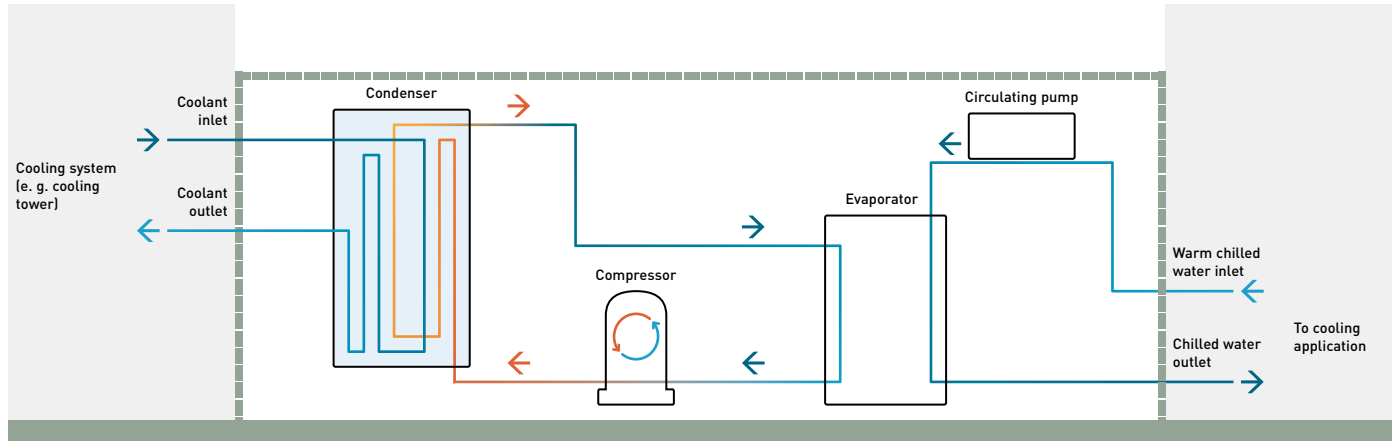

**Ecodesign**

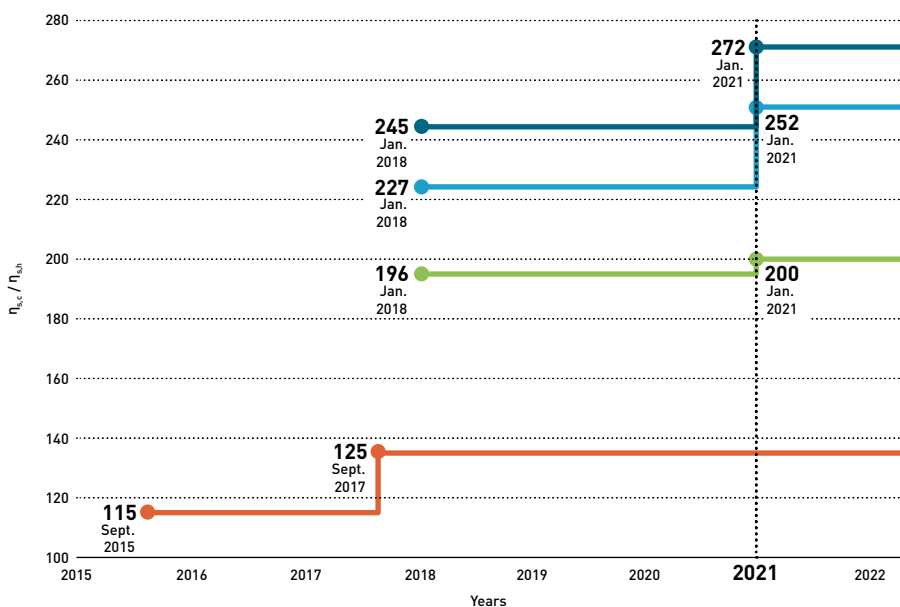

**Water to water comfort chiller <sup>1)</sup>**

- ≤400 kW. Minimum η<sub>cc</sub> to be Ecodesign compliant. COMMISSION REGULATION (EU) 2016/2281.
- >400 kW and ≤1500 kW. Minimum η<sub>cc</sub> to be Ecodesign compliant. COMMISSION REGULATION (EU) 2016/2281.
- >1500 kW. Minimum η<sub>cc</sub> to be Ecodesign compliant. COMMISSION REGULATION (EU) 2016/2281.

**Water to water heat pumps <sup>2)</sup>**





- ≤400 kW. Minimum η<sub>sh</sub> to be Ecodesign compliant. COMMISSION REGULATION (EU) No813/2013.
- >400 kW and ≤1500 kW. Minimum η<sub>sh</sub> to be Ecodesign compliant. COMMISSION REGULATION (EU) 2016/2281.
- >1500 kW. Minimum η<sub>sh</sub> to be Ecodesign compliant. COMMISSION REGULATION (EU) 2016/2281.

1) Calculated at nominal conditions: chilled water inlet/outlet temperature: 12/7 °C, outdoor ambient temperature 30/35 °C DB.  
 2) Rated heat output of space heaters and combination heaters at reference design conditions [T<sub>design</sub> -10 °C] as stated in COMMISSION REGULATION (EU) No 813/2013.

# Quick selection guide - Water cooled chillers

Page	Size	Cooling capacity (kW)	SEER	Sound power (dB(A))	Dimension LxHxW (mm)
<b>ECOi-W WQ C</b>	20	21,2	5,58	65	821 x 1350 x 455
	25	26,2	5,60	67	821 x 1350 x 455
	30	31,1	5,45	67	821 x 1350 x 455
	35	34,8	5,50	68	821 x 1350 x 455
	40	39,2	5,35	68	821 x 1350 x 455
	45	46,6	5,83	70	821 x 1350 x 455
<b>P. 516</b>	50	50,9	6,13	70	1210 x 1500 x 850
	60	61,1	6,38	70	1210 x 1500 x 850
	75	77,3	5,95	72	1210 x 1500 x 850
	90	91,1	6,70	73	1210 x 1500 x 850
	120	118,4	5,90	78	1210 x 1500 x 850
	150	147,1	6,13	81	1210 x 1500 x 850
<b>P. 516</b>	170	170	6,08	81	1210 x 1500 x 850
	190	192,7	6,20	81	1210 x 1500 x 850
	524	154,3	5,55	81	2250 x 1845 x 850
	604	181,8	6,28	82	2250 x 1845 x 850
	704	208,9	6,10	85	2250 x 1845 x 850
	804	232,6	5,75	87	2250 x 1845 x 850
<b>P. 518</b>	904	265,8	6,10	89	2250 x 1845 x 850
	1004	295,6	6,10	90	2250 x 1845 x 850
	1104	338	6,20	90	2250 x 1845 x 850
	1204	379,2	6,25	90	2250 x 1845 x 850
	1404	421,1	6,43	92	2250 x 1845 x 850
	1604	459,8	6,47	94	2250 x 1845 x 850
<b>ECOi-W WSW-N EVO C</b>	440	418,6	6,38	95	4250 x 1650 x 1350
	490	471,6	6,38	95	4250 x 1650 x 1350
	570	539,3	6,52	95	4210 x 1650 x 1350
	630	601,9	6,42	95	4210 x 1650 x 1350
	700	664,4	6,38	95	4180 x 1650 x 1350
	770	734,6	6,38	95	4180 x 1650 x 1350
<b>P. 520</b>	860	825,0	6,41	98	4510 x 1710 x 1520
	920	874,1	6,41	98	4510 x 1710 x 1520
	990	936,6	6,41	98	4600 x 1710 x 1520
	1070	1019,1	6,42	98	4650 x 1710 x 1520
	1130	1071,8	6,53	98	4650 x 1710 x 1520
	1220	1159,3	6,51	98	4650 x 1710 x 1520
<b>P. 520</b>	1280	1226,1	6,44	98	4650 x 1710 x 1520
	1400	1334,6	6,45	98	5350 x 1710 x 1520
	1550	1457,9	6,42	98	5350 x 1710 x 1520

# Quick selection guide - Water cooled heat pumps

Page	Size	Cooling and heating capacity (kW)	SEER / SCOP	Sound power (dB(A))	Dimension LxHxW (mm)	
P. 516		20	20,8 / 23,7	5,13 / 5,17	65	821 x 1350 x 455
		25	26,0 / 28,9	5,00 / 5,45	67	821 x 1350 x 455
		30	30,1 / 33,6	4,88 / 5,33	67	821 x 1350 x 455
		35	34,0 / 38,5	5,10 / 5,05	68	821 x 1350 x 455
		40	38,2 / 42,9	5,00 / 4,83	68	821 x 1350 x 455
		45	45,5 / 51,2	5,47 / 5,28	70	821 x 1350 x 455
P. 516		50	49,9 / 57,7	4,70 / 5,70	70	1210 x 1500 x 850
		60	58,9 / 68,2	4,88 / 5,88	70	1210 x 1500 x 850
		75	76,1 / 86,3	4,47 / 5,70	72	1210 x 1500 x 850
		90	88,6 / 102,2	4,83 / 5,78	73	1210 x 1500 x 850
		120	114,9 / 132	4,92 / 5,75	78	1210 x 1500 x 850
		150	144,3 / 164,2	4,97 / 5,63	81	1210 x 1500 x 850
P. 518		170	165,7 / 190,1	5,65 / 5,95	81	1210 x 1500 x 850
		190	185,4 / 212,3	5,10 / 5,63	81	1210 x 1500 x 850
		524	150,7 / 170,2	4,65 / 5,40	81	2250 x 1845 x 850
		604	176,2 / 201,1	4,92 / 5,20	82	2250 x 1845 x 850
		704	204,5 / 231,8	4,92 / 5,38	85	2250 x 1845 x 850
		804	225,4 / 256,5	4,68 / 5,35	87	2250 x 1845 x 850
		904	263,1 / 295,6	5,15 / 5,73	89	2250 x 1845 x 850
		1004	291,3 / 331	5,10 / 5,85	90	2250 x 1845 x 850
		1104	332 / 376,6	5,27 / 5,83	90	2250 x 1845 x 850
		1204	370,5 / 418,5	5,30 / 5,85	90	2250 x 1845 x 850
		1404	421,1 / 468,0	6,43 / —	92	2250 x 1845 x 850
		1604	459,8 / 508,4	6,47 / —	94	2250 x 1845 x 850
P. 520		440	365,9 / 470,3	6,53 / 4,46	95	4590 x 1650 x 1450
		490	418,9 / 536,5	6,38 / 4,52	95	4590 x 1650 x 1450
		570	483,2 / 621,7	6,40 / 4,4	95	4630 x 1650 x 1450
		630	541,0 / 698,6	6,38 / 4,31	95	4630 x 1650 x 1450
		700	595,6 / 764,7	6,45 / 4,47	95	4320 x 1650 x 1450
		770	646,6 / 835,9	6,60 / 4,37	95	4560 x 1650 x 1450
		860	715,5 / 923,0	6,40 / 4,39	98	5110 x 1680 x 1520
		920	772,0 / 992,7	6,50 / 4,44	98	5110 x 1680 x 1520
		990	828,1 / 1063,0	6,40 / 4,49	98	5100 x 1680 x 1520
		1070	891,5 / 1146,0	6,40 / 4,45	98	5100 x 1680 x 1520
		1130	958,8 / 1231,8	6,50 / 4,45	98	5000 x 1680 x 1520
		1220	1023,8 / 1315,8	6,48 / 4,41	98	5000 x 1680 x 1520
		1280	1078,2 / 1386,1	6,48 / 4,37	98	5000 x 1680 x 1520
		1400	1186,9 / 1523,8	6,50 / 4,45	98	5300 x 1710 x 1580
		1550	1285,5 / 1654,6	6,70 / 4,38	98	5300 x 1710 x 1580

# Quick selection guide - Water cooled condenserless units

Page	Size	Cooling capacity (kW)	Sound power (dB(A))	Dimension LxWxH (mm)
<b>ECOi-W WQ R</b>	20	18,3	65	821 x 1350 x 455
	25	22,7	67	821 x 1350 x 455
	30	27,1	67	821 x 1350 x 455
	35	30,0	68	821 x 1350 x 455
	40	34,2	68	821 x 1350 x 455
	45	43,1	70	821 x 1350 x 455
<b>P. 516</b>	50	45,0	70	1210 x 1500 x 850
	60	53,4	70	1210 x 1500 x 850
	75	67,5	72	1210 x 1500 x 850
	90	80,1	73	1210 x 1500 x 850
	120	104,0	78	1210 x 1500 x 850
	150	128,0	81	1210 x 1500 x 850
<b>P. 516</b>	170	148,0	81	1210 x 1500 x 850
	190	168,0	81	1210 x 1500 x 850
	524	130,0	81	2250 x 1845 x 850
	604	155,3	82	2250 x 1845 x 850
	704	177,6	85	2250 x 1845 x 850
	804	196,5	87	2250 x 1845 x 850
<b>P. 518</b>	904	224,2	89	2250 x 1845 x 850
	1004	247,2	90	2250 x 1845 x 850
	1104	285,9	90	2250 x 1845 x 850
	1204	316,1	90	2250 x 1845 x 850
	1404	368,0	92	2250 x 1845 x 850
	1604	397,0	94	2250 x 1845 x 850
<b>ECOi-W WSW-N EVO R</b>	440	358,6	95	4590 x 1650 x 1450
	490	405,3	95	4590 x 1650 x 1450
	570	472,7	95	4630 x 1650 x 1450
	630	535,6	95	4630 x 1650 x 1450
	700	586,2	95	4320 x 1650 x 1450
	770	638,1	95	4560 x 1650 x 1450
<b>P. 520</b>	860	708,9	98	5110 x 1680 x 1520
	920	758,1	98	5110 x 1680 x 1520
	990	817,2	98	5100 x 1680 x 1520
	1070	886,2	98	5100 x 1680 x 1520
	1130	947,7	98	5000 x 1680 x 1520
	1220	1015,0	98	5000 x 1680 x 1520
	1280	1075,9	98	5000 x 1680 x 1520
	1400	1181,4	98	5300 x 1710 x 1580
	1550	1277,8	98	5300 x 1710 x 1580

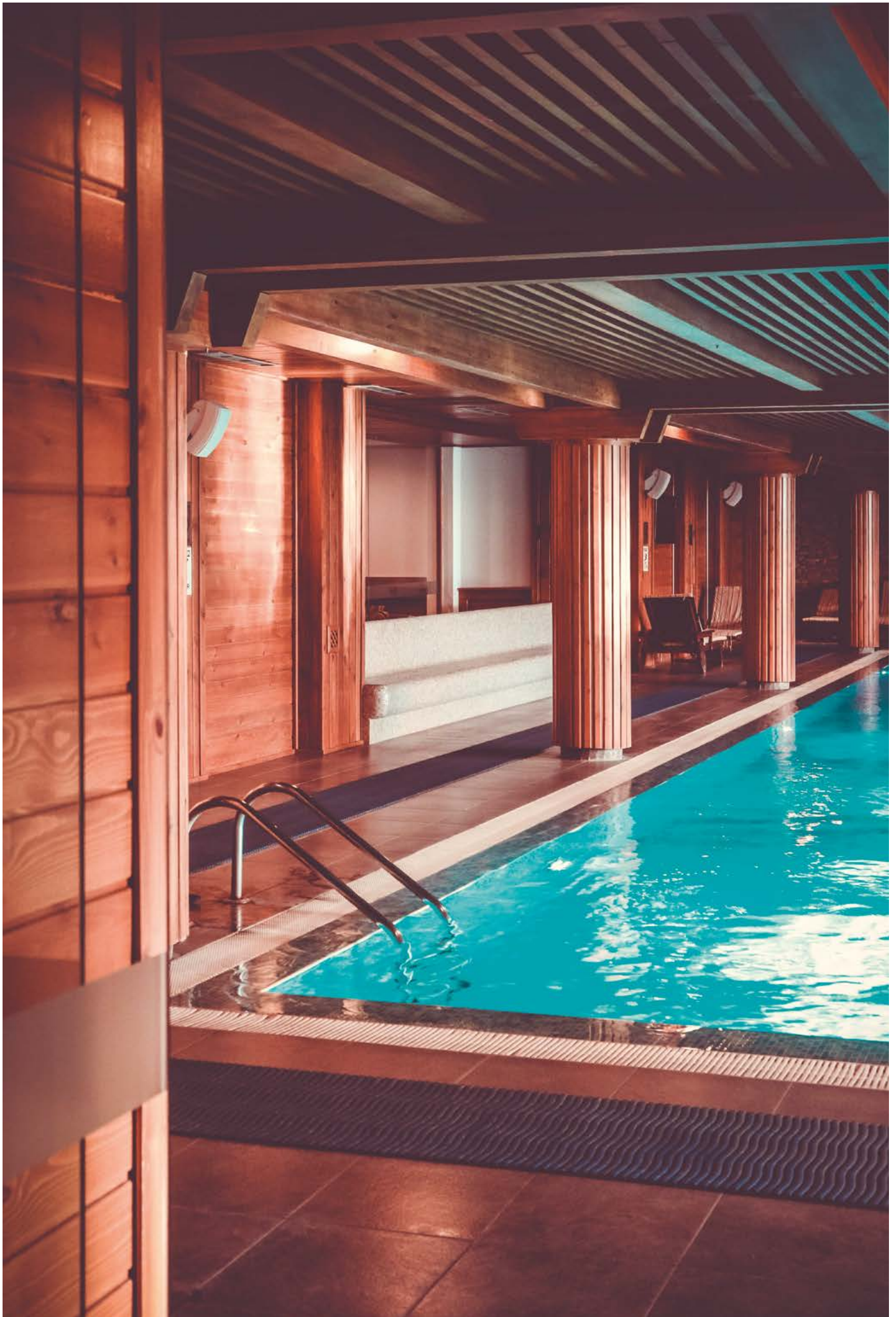



# ECOi-W WQ 20-190 C/H/R · R410A

Water cooled chillers, heat pumps and condenserless units.

Cooling capacity: 21,2 to 192,7 kW.

Heating capacity: 23,7 to 212,3 kW.



## Operating limits

To be confirmed with AC SELECT:  
<https://acselect.panasonic.eu/>

Leaving water temperature.

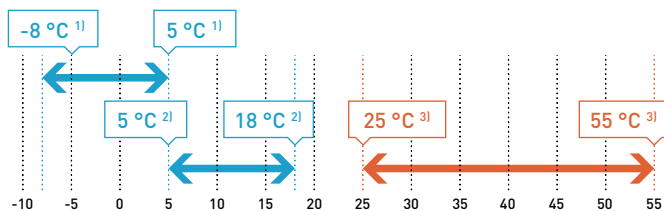

1) With glycol + EEV.

2) Without glycol + EEV.

3) Only C/H types 20-190.

Note: maximum % glycol (ethylene or propylene): 40%.

## ECOi-W WQ 20-190 C/H/R

Cooling	Leaving water temperature	$\Delta T$	K	From 3 to 8
Heating <sup>1)</sup>	Leaving water temperature	$\Delta T$	K	From 3 to 15

1) Only C/H types 20-190.

## Accessories and options

Compressor jackets  
 Desuperheater available for sizes 50-190  
 Hydrokit with 1 or 2 pumps for evaporator and condenser  
 Mechanical gauges kit  
 Modbus communication protocol

## The range at a glance

- 3 versions: C (chiller), H (heat pump) and R (condenserless unit)
- 14 sizes
- 2 acoustic options: STD (standard) and S (super low noise)
- 2 frames: F1 (size from 20 to 45) and F2 (size from 50 to 190)

## Advantages

- High full load efficiency: EER up to 4,50, COP up to 3,90
- High seasonal performances: SEER up to 6,70
- Compressor box: remarkable sound reduction
- Reduced refrigerant charge: less than 10 kg per circuit for units up to size 90
- Advanced electronic controller: auto-adaptive function to reduce water content in the piping system
- Condensing pressure control option suitable for well application
- Wide range of Plug & Play hydrokit: easy hydraulic installation
- DHW function available on the controller with DHW probe and 3 way valve available as options
- Desuperheater heat exchanger available as option (50-190 sizes)

## Equipment

- 1 refrigerant circuit
- 1 or 2 scroll compressors
- Plate evaporator (AISI 316)
- Compressor acoustic box (standard on S)
- Differential pressure switch
- Electronic expansion valve (standard C type 170-190)
- Phase sequence control

## Accessories and options

Power factor corrector capacitors  
 Soft starter  
 Water filter  
 Water flow switch

## AC SELECT.

Smart and user-friendly the new air conditioning selection program: <https://acselect.panasonic.eu/>





### Technical performance

		Voltage	V	400	400	400	400	400	400	400	400	400	400	400	400	400
Power supply	Phase		Three phase	Three phase	Three phase	Three phase	Three phase	Three phase	Three phase	Three phase	Three phase	Three phase	Three phase	Three phase	Three phase	Three phase
	Frequency	Hz	50	50	50	50	50	50	50	50	50	50	50	50	50	50
	<b>Size</b>		<b>20</b>	<b>25</b>	<b>30</b>	<b>35</b>	<b>40</b>	<b>45</b>	<b>50</b>	<b>60</b>	<b>75</b>	<b>90</b>	<b>120</b>	<b>150</b>	<b>170</b>	<b>190</b>
<b>ECOi-W WQ 20-190 C - chiller</b>		<b>P-WQE****CA</b>	<b>0020</b>	<b>0025</b>	<b>0030</b>	<b>0035</b>	<b>0040</b>	<b>0045</b>	<b>0050</b>	<b>0060</b>	<b>0075</b>	<b>0090</b>	<b>0120</b>	<b>0150</b>	<b>0170</b>	<b>0190</b>
Cooling capacity <sup>1)</sup>	kW	21,2	26,2	31,1	34,8	39,2	46,6	50,9	61,1	77,3	91,1	118,4	147,1	170,0	192,7	
Input power <sup>1)</sup>	kW	4,56	5,67	6,84	7,54	8,60	10,1	11,7	13,5	17,1	20,7	26,5	33,0	37,7	42,8	
EER <sup>1)</sup>		4,67	4,65	4,57	4,64	4,58	4,65	4,35	4,53	4,52	4,40	4,48	4,47	4,51	4,51	
<b>SEER <sup>2)3)</sup></b>		<b>5,58</b>	<b>5,6</b>	<b>5,45</b>	<b>5,5</b>	<b>5,35</b>	<b>5,83</b>	<b>6,13</b>	<b>6,38</b>	<b>5,95</b>	<b>6,7</b>	<b>5,90</b>	<b>6,13</b>	<b>6,08</b>	<b>6,2</b>	
$\eta_{s,c}$ <sup>2)3)</sup>		<b>220</b>	<b>221</b>	<b>215</b>	<b>217</b>	<b>211</b>	<b>230</b>	<b>242</b>	<b>252</b>	<b>235</b>	<b>265</b>	<b>233</b>	<b>242</b>	<b>240</b>	<b>245</b>	
Sound power (STD / S) <sup>4)</sup>	dB(A)	65 / 62	67 / 64	67 / 64	68 / 65	68 / 66	70 / 67	70 / 68	70 / 68	72 / 70	73 / 71	78 / 76	81 / 79	81 / 79	81 / 79	
Sound pressure at 10 m (STD / S) <sup>5)</sup>	dB(A)	34 / 31	36 / 33	36 / 33	37 / 34	38 / 35	39 / 36	39 / 37	39 / 37	40 / 39	42 / 40	47 / 45	50 / 48	50 / 48	50 / 48	
<b>ECOi-W WQ 20-190 H - heat pump</b>		<b>P-WQE****HA</b>	<b>0020</b>	<b>0025</b>	<b>0030</b>	<b>0035</b>	<b>0040</b>	<b>0045</b>	<b>0050</b>	<b>0060</b>	<b>0075</b>	<b>0090</b>	<b>0120</b>	<b>0150</b>	<b>0170</b>	<b>0190</b>
Cooling capacity <sup>1)</sup>	kW	20,8	26,1	30,2	34,1	38,3	45,7	49,9	58,9	76,1	88,6	114,9	144,3	165,7	185,4	
Input power <sup>1)</sup>	kW	4,61	5,71	6,90	7,68	8,69	10,2	12,0	13,9	17,5	21,1	27,0	33,3	38,2	43,3	
EER <sup>1)</sup>		4,52	4,56	4,37	4,44	4,41	4,46	4,23	4,31	4,42	4,25	4,31	4,36	4,37	4,30	
<b>SEER <sup>2)</sup></b>		<b>5,13</b>	<b>5</b>	<b>4,88</b>	<b>5,1</b>	<b>5</b>	<b>5,48</b>	<b>4,7</b>	<b>4,88</b>	<b>4,47</b>	<b>4,83</b>	<b>4,92</b>	<b>4,97</b>	<b>5,65</b>	<b>5,1</b>	
$\eta_{s,c}$ <sup>2)</sup>		<b>202</b>	<b>197</b>	<b>192</b>	<b>201</b>	<b>197</b>	<b>216</b>	<b>185</b>	<b>192</b>	<b>176</b>	<b>190</b>	<b>194</b>	<b>196</b>	<b>223</b>	<b>201</b>	
Heating capacity <sup>6)</sup>	kW	23,9	29,1	34,0	38,8	43,3	51,5	58,8	65,9	87,7	104	134	167	193	215	
Input power <sup>6)</sup>	kW	5,77	7,06	8,36	9,50	10,6	12,5	14,1	16,8	20,8	24,9	32,1	39,4	45,9	51,4	
COP <sup>6)</sup>		4,13	4,13	4,07	4,09	4,08	4,11	4,16	3,93	4,22	4,16	4,17	4,23	4,20	4,19	
COP <sup>7)</sup>		5,66	5,62	5,58	5,60	5,52	5,24	5,32	5,12	5,43	5,23	5,29	5,38	5,33	5,33	
<b>SCOP <sup>8)9)</sup></b>		<b>5,30</b>	<b>5,45</b>	<b>5,33</b>	<b>5,05</b>	<b>4,83</b>	<b>5,28</b>	<b>5,70</b>	<b>5,88</b>	<b>5,70</b>	<b>5,78</b>	<b>5,75</b>	<b>5,63</b>	<b>5,95</b>	<b>5,63</b>	
Energy efficiency class <sup>8)9)</sup>	<b>A+++ to D</b>	<b>A+++</b>	<b>A+++</b>	<b>A+++</b>	<b>A+++</b>	<b>A+++</b>	<b>A+++</b>	<b>A+++</b>	<b>A+++</b>	<b>A+++</b>	<b>A+++</b>	<b>A+++</b>	<b>A+++</b>	<b>A+++</b>	<b>A+++</b>	<b>A+++</b>
$\eta_{s,h}$ <sup>8)9)</sup>		<b>204</b>	<b>210</b>	<b>205</b>	<b>194</b>	<b>185</b>	<b>203</b>	<b>220</b>	<b>227</b>	<b>220</b>	<b>223</b>	<b>222</b>	<b>217</b>	<b>230</b>	<b>217</b>	
<b>SCOP <sup>8)10)</sup></b>		<b>4,00</b>	<b>4,48</b>	<b>4,45</b>	<b>4,30</b>	<b>4,28</b>	<b>4,45</b>	<b>4,63</b>	<b>4,78</b>	<b>4,75</b>	<b>4,75</b>	<b>4,73</b>	<b>4,48</b>	<b>4,88</b>	<b>4,68</b>	
Energy efficiency class <sup>8)10)</sup>	<b>A+++ to D</b>	<b>A+++</b>	<b>A+++</b>	<b>A+++</b>	<b>A+++</b>	<b>A+++</b>	<b>A+++</b>	<b>A+++</b>	<b>A+++</b>	<b>A+++</b>	<b>A+++</b>	<b>A+++</b>	<b>A+++</b>	<b>A+++</b>	<b>A+++</b>	<b>A+++</b>
$\eta_{s,h}$ <sup>8)10)</sup>		<b>152</b>	<b>171</b>	<b>170</b>	<b>164</b>	<b>163</b>	<b>170</b>	<b>177</b>	<b>183</b>	<b>182</b>	<b>182</b>	<b>181</b>	<b>171</b>	<b>187</b>	<b>179</b>	
Sound power (STD / S) <sup>4)</sup>	dB(A)	65 / 62	67 / 64	67 / 64	68 / 65	69 / 66	70 / 67	70 / 68	70 / 68	72 / 70	73 / 71	78 / 76	81 / 79	81 / 79	81 / 79	
Sound pressure at 10 m (STD / S) <sup>5)</sup>	dB(A)	34 / 31	36 / 33	36 / 33	37 / 34	38 / 35	39 / 36	39 / 37	39 / 37	40 / 39	42 / 40	47 / 45	50 / 48	50 / 48	50 / 48	
<b>ECOi-W WQ 20-190 R - condenserless unit</b>		<b>P-WQE****RA</b>	<b>0020</b>	<b>0025</b>	<b>0030</b>	<b>0035</b>	<b>0040</b>	<b>0045</b>	<b>0050</b>	<b>0060</b>	<b>0075</b>	<b>0090</b>	<b>0120</b>	<b>0150</b>	<b>0170</b>	<b>0190</b>
Cooling capacity <sup>11)</sup>	kW	18,3	22,7	27,1	30,0	34,2	43,1	45,0	53,4	67,5	80,1	104,0	128,0	148,0	168,0	
Input power <sup>11)</sup>	kW	5,70	6,97	8,07	9,15	10,1	12,2	13,7	16	20,1	23,9	30,8	38,1	44,2	49,7	
Sound power (STD / S) <sup>4)</sup>	dB(A)	65/62	67 / 64	67 / 64	68 / 65	69 / 66	70 / 67	70 / 68	70 / 68	72 / 70	73 / 71	78 / 76	81 / 79	81 / 79	81 / 79	
Sound pressure at 10 m (STD / S) <sup>5)</sup>	dB(A)	34/31	36 / 33	36 / 33	37 / 34	38 / 35	39 / 36	39 / 37	39 / 37	41 / 39	42 / 40	47 / 45	50 / 48	50 / 48	50 / 48	

### Physical features

<b>ECOi-W WQ 20-190 C/H - chiller / heat pump</b>		<b>20</b>	<b>25</b>	<b>30</b>	<b>35</b>	<b>40</b>	<b>45</b>	<b>50</b>	<b>60</b>	<b>75</b>	<b>90</b>	<b>120</b>	<b>150</b>	<b>170</b>	<b>190</b>	
Dimension	Height	mm	1350	1350	1350	1350	1350	1500	1500	1500	1500	1500	1500	1500	1500	
	Width	mm	455	455	455	455	455	850	850	850	850	850	850	850	850	
	Length	mm	821	821	821	821	821	1210	1210	1210	1210	1210	1210	1210	1210	
Operating weight	Chiller	kg	162	182	179	185	191	214	352	371	392	411	597	666	701	745
	Heat pump	kg	165	187	184	190	195	219	360	379	403	422	610	683	718	762
<b>Water connections (evaporator and condenser)</b>																
Connection type		Victaulic®	Victaulic®	Victaulic®	Victaulic®	Victaulic®	Victaulic®	Victaulic®	Victaulic®	Victaulic®	Victaulic®	Victaulic®	Victaulic®	Victaulic®	Victaulic®	Victaulic®
Inlet/outlet diameter	Inch	1 1/2	1 1/2	1 1/2	1 1/2	1 1/2	1 1/2	2 1/2	2 1/2	2 1/2	2 1/2	2 1/2	2 1/2	2 1/2	2 1/2	
<b>ECOi-W WQ 20-190 R - condenserless unit</b>		<b>20</b>	<b>25</b>	<b>30</b>	<b>35</b>	<b>40</b>	<b>45</b>	<b>50</b>	<b>60</b>	<b>75</b>	<b>90</b>	<b>120</b>	<b>150</b>	<b>170</b>	<b>190</b>	
Dimension	Height	mm	1350	1350	1350	1350	1350	1500	1500	1500	1500	1500	1500	1500	1500	
	Width	mm	455	455	455	455	455	850	850	850	850	850	850	850	850	
	Length	mm	821	821	821	821	821	1210	1210	1210	1210	1210	1210	1210	1210	
Operating weight	kg	144	164	166	166	172	172	332	344	365	376	558	612	643	674	
<b>Water connections (evaporator)</b>																
Connection type		Victaulic®	Victaulic®	Victaulic®	Victaulic®	Victaulic®	Victaulic®	Victaulic®	Victaulic®	Victaulic®	Victaulic®	Victaulic®	Victaulic®	Victaulic®	Victaulic®	Victaulic®
Inlet/outlet diameter	Inch	1 1/2	1 1/2	1 1/2	1 1/2	1 1/2	1 1/2	2 1/2	2 1/2	2 1/2	2 1/2	2 1/2	2 1/2	2 1/2	2 1/2	
<b>Remote condenser refrigerant connections</b>																
Connection type		To be brazed	To be brazed	To be brazed	To be brazed	To be brazed	To be brazed	To be brazed	To be brazed	To be brazed	To be brazed	To be brazed	To be brazed	To be brazed	To be brazed	To be brazed
Inlet diameter	Inch	5/8	5/8	5/8	5/8	5/8	5/8	5/8	5/8	7/8	7/8	7/8	7/8	1 1/8	1 1/8	
Outlet diameter	Inch	5/8	7/8	7/8	7/8	7/8	7/8	7/8	7/8	1 1/8	1 1/8	1 3/8	1 5/8	1 5/8	1 5/8	

1) According to EN14511 standard: evaporator EWT/LWT 12 °C/7 °C, condenser EWT/LWT 30 °C/35 °C. 2) According to EN14825 standard. 3) ErP compliant: following COMMISSION REGULATION (EU) 2016/2281. 4) Sound levels are at fully loaded conditions. Sound power values refers to ISO 3744 standard. 5) Sound pressures refer to ISO 3744 standard, parallelepiped shape. 6) According to EN14511 standard: evaporator EWT/LWT 10 °C/7 °C, condenser EWT/LWT 40 °C/45 °C. 7) According to EN14511 standard: evaporator EWT/LWT 10 °C/7 °C, condenser EWT/LWT 30 °C/35 °C. 8) ErP compliant: following COMMISSION REGULATION (EU) No 813/2013. 9) According to EN14825 standard - low temperature application [35 °C]. 10) According to EN14825 standard - medium temperature application [55 °C]. 11) Data refers to evaporator water temperature 12/7 °C and condensing temperature 50 °C.

ErP

HIGH SEER  
6,70

HIGH SCOP  
5,88

WATER COOLED

PLATE HEAT EXCHANGER

SCROLL COMPRESSOR

SUPER QUIET

VERY HIGH PERFORMANCE

EUROVENT CERTIFIED PERFORMANCE



# ECOi-W WQ 524-1604 C/H/R - R410A

Water cooled chillers, heat pumps and condenserless units.

Cooling capacity: 154,3 to 459,8 kW.

Heating capacity: 170,2 to 508,4 kW.



## The range at a glance

- 3 versions: C (chiller), H (heat pump) and R (condenserless unit)
- 10 sizes
- 2 acoustic options: STD (standard) and S (super low noise)

## Advantages

- High full load efficiency: EER up to 4,50, COP up to 3,90
- High seasonal performances: SEER up to 6,50
- Advanced electronic controller: auto-adaptive function to reduce water content in the piping system
- Condensing pressure control option: suitable for well application
- Wide range of Plug & Play hydrokit: easy hydraulic installation
- Desuperheater heat exchanger available as option: heating capacity for free thanks to heat recovery

## Operating limits

To be confirmed with AC SELECT:

<https://acselect.panasonic.eu/>

Leaving water temperature.

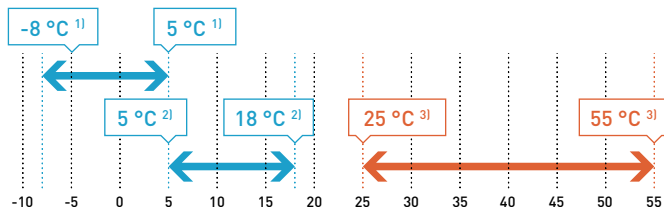

1) With glycol + EEV.

2) Without glycol + EEV.

3) Only C/H types 20-190.

Note: maximum % glycol (ethylene or propylene): 40%.

## ECOi-W WQ 524-1604 C/H/R

Cooling	Leaving water temperature	$\Delta T$	K	From 3 to 8
Heating	Leaving water temperature	$\Delta T$	K	From 3 to 15

## Accessories and options

Desuperheater  
Hydrokit with 1 or 2 pumps for evaporator and condenser  
Mechanical gauges  
Modbus communication protocol

## Equipment

- 2 refrigerant circuits
- Four scroll compressors (tandem)
- Plate evaporator (AISI 316)
- Differential pressure switch
- Electronic expansion valve (standard 1104-1604)
- Phase sequence control

## Accessories and options

Soft starter  
Water filter  
Water flow switch

## AC SELECT.

Smart and user-friendly the new air conditioning selection program: <https://acselect.panasonic.eu/>





## Technical performance

	Voltage	V	400	400	400	400	400	400	400	400	400	400
Power supply	Phase		Three phase	Three phase	Three phase	Three phase	Three phase	Three phase	Three phase	Three phase	Three phase	Three phase
	Frequency	Hz	50	50	50	50	50	50	50	50	50	50
Size			<b>524</b>	<b>604</b>	<b>704</b>	<b>804</b>	<b>904</b>	<b>1004</b>	<b>1104</b>	<b>1204</b>	<b>1404</b>	<b>1604</b>
<b>ECOi-W WQ 524-1604 C - chiller</b>	<b>P-</b>	<b>WQE0524CA</b>	<b>WQE0604CA</b>	<b>WQE0704CA</b>	<b>WQE0804CA</b>	<b>WQE0904CA</b>	<b>WQE1004CA</b>	<b>WQE1104CA</b>	<b>WQE1204CA</b>	<b>WQE1404CA</b>	<b>WQE1604CA</b>	
Cooling capacity <sup>1)</sup>	kW	154,3	181,8	208,9	232,6	265,8	295,6	338,0	379,2	421,1	459,8	
Input power <sup>1)</sup>	kW	34,2	41,6	47,5	53,3	59,3	65,7	74,9	83,4	95,0	107,3	
EER <sup>1)</sup>		4,51	4,37	4,40	4,36	4,48	4,51	4,51	4,56	4,43	4,28	
<b>SEER <sup>2)3)</sup></b>		<b>5,55</b>	<b>6,28</b>	<b>6,1</b>	<b>5,75</b>	<b>6,1</b>	<b>6,1</b>	<b>6,2</b>	<b>6,25</b>	<b>6,43</b>	<b>6,47</b>	
$\eta_{s,c}$ <sup>2)3)</sup>		<b>219</b>	<b>248</b>	<b>241</b>	<b>227</b>	<b>241</b>	<b>241</b>	<b>245</b>	<b>247</b>	<b>254</b>	<b>256</b>	
Sound power [STD / S] <sup>4)</sup>	dB(A)	81 / 75	82 / 76	85 / 79	87 / 81	89 / 83	90 / 84	90 / 84	90 / 84	92 / 86	94 / 88	
Sound pressure at 10 m [STD / S] <sup>5)</sup>	dB(A)	49 / 43	50 / 44	53 / 47	55 / 49	57 / 51	58 / 52	58 / 52	58 / 52	60 / 54	62 / 56	
<b>ECOi-W WQ 524-1604 H - heat pump</b>	<b>P-</b>	<b>WQE0524HA</b>	<b>WQE0604HA</b>	<b>WQE0704HA</b>	<b>WQE0804HA</b>	<b>WQE0904HA</b>	<b>WQE1004HA</b>	<b>WQE1104HA</b>	<b>WQE1204HA</b>	<b>WQE1404HA</b>	<b>WQE1604HA</b>	
Cooling capacity <sup>1)</sup>	kW	150,7	176,2	204,5	225,4	263,1	291,3	332,0	370,5	421,1	459,8	
Input power <sup>1)</sup>	kW	34,9	42,7	48,3	54,3	59,8	66,4	76,2	85,2	95,0	107,3	
EER <sup>1)</sup>		4,32	4,13	4,23	4,15	4,40	4,39	4,36	4,35	4,43	4,28	
<b>SEER <sup>2)</sup></b>		<b>4,65</b>	<b>4,92</b>	<b>4,92</b>	<b>4,68</b>	<b>5,15</b>	<b>5,1</b>	<b>5,27</b>	<b>5,3</b>	<b>6,43</b>	<b>6,47</b>	
$\eta_{s,c}$ <sup>2)</sup>		<b>183</b>	<b>194</b>	<b>194</b>	<b>184</b>	<b>203</b>	<b>201</b>	<b>208</b>	<b>209</b>	<b>254</b>	<b>256</b>	
Heating capacity <sup>6)</sup>	kW	172	203	234	259	298	333	380	422	471	509	
Input power <sup>6)</sup>	kW	41,9	50,8	57,6	65,1	72,5	80,8	92,1	103	121	135	
COP <sup>6)</sup>		4,11	4,00	4,07	3,99	4,12	4,12	4,12	4,10	3,91	3,76	
COP <sup>7)</sup>		5,36	5,08	5,25	5,11	5,33	5,44	5,30	5,30	5,08	4,99	
<b>SCOP <sup>8)9)</sup></b>		<b>5,40</b>	<b>5,20</b>	<b>5,38</b>	<b>5,35</b>	<b>5,73</b>	<b>5,85</b>	<b>5,83</b>	<b>5,85</b>	—	—	
$\eta_{s,h}$ <sup>8)9)</sup>		<b>208</b>	<b>200</b>	<b>207</b>	<b>206</b>	<b>221</b>	<b>226</b>	<b>225</b>	<b>226</b>	—	—	
<b>SCOP <sup>8)10)</sup></b>		<b>4,55</b>	<b>4,38</b>	<b>4,48</b>	<b>4,43</b>	<b>4,53</b>	<b>4,58</b>	<b>4,60</b>	<b>4,60</b>	—	—	
$\eta_{s,h}$ <sup>8)10)</sup>		<b>174</b>	<b>167</b>	<b>171</b>	<b>169</b>	<b>173</b>	<b>175</b>	<b>176</b>	<b>176</b>	—	—	
Sound power [STD / S] <sup>4)</sup>	dB(A)	81 / 75	82 / 76	85 / 79	87 / 81	89 / 83	90 / 84	90 / 84	90 / 84	92 / 86	94 / 88	
Sound pressure at 10 m [STD / S] <sup>5)</sup>	dB(A)	49 / 43	50 / 44	53 / 47	55 / 49	57 / 51	58 / 52	58 / 52	58 / 52	60 / 54	62 / 56	
<b>ECOi-W WQ 524-1604 R - condenserless unit</b>	<b>P-</b>	<b>WQE0524RA</b>	<b>WQE0604RA</b>	<b>WQE0704RA</b>	<b>WQE0804RA</b>	<b>WQE0904RA</b>	<b>WQE1004RA</b>	<b>WQE1104RA</b>	<b>WQE1204RA</b>	<b>WQE1404RA</b>	<b>WQE1604RA</b>	
Cooling capacity <sup>11)</sup>	kW	130,0	155,3	177,6	196,5	224,2	247,2	285,9	316,1	368,0	397,0	
Input power <sup>11)</sup>	kW	43,2	51,5	59,5	66,4	74,8	83	95	106	120	134	
Sound power [STD / S] <sup>4)</sup>	dB(A)	81 / 75	82 / 76	85 / 79	87 / 81	89 / 83	90 / 84	90 / 84	90 / 84	92 / 86	94 / 88	
Sound pressure at 10 m [STD / S] <sup>5)</sup>	dB(A)	49 / 43	50 / 44	53 / 47	55 / 49	57 / 51	58 / 52	58 / 52	58 / 52	60 / 54	62 / 56	

## Physical features

<b>ECOi-W WQ 524-1604 C/H/R - chiller / heat pump / condenserless unit</b>			<b>524</b>	<b>604</b>	<b>704</b>	<b>804</b>	<b>904</b>	<b>1004</b>	<b>1104</b>	<b>1204</b>	<b>1404</b>	<b>1604</b>	
Dimension	Height	mm	1845 <sup>12)</sup> / 1880 <sup>13)</sup>	1845 <sup>12)</sup> / 1880 <sup>13)</sup>	1845 <sup>12)</sup> / 1880 <sup>13)</sup>	1845 <sup>12)</sup> / 1880 <sup>13)</sup>	1845 <sup>12)</sup> / 1880 <sup>13)</sup>	1845 <sup>12)</sup> / 1880 <sup>13)</sup>	1845 <sup>12)</sup> / 1880 <sup>13)</sup>	1845 <sup>12)</sup> / 1880 <sup>13)</sup>	1845 <sup>12)</sup> / 1880 <sup>13)</sup>	1845 <sup>12)</sup> / 1880 <sup>13)</sup>	
		mm	850 <sup>12)</sup> / 854 <sup>13)</sup> / 885 <sup>12)14)</sup> - 1005 <sup>13)14)</sup>	850 <sup>12)</sup> / 854 <sup>13)</sup> / 885 <sup>12)14)</sup> - 1005 <sup>13)14)</sup>	850 <sup>12)</sup> / 854 <sup>13)</sup> / 885 <sup>12)14)</sup> - 1005 <sup>13)14)</sup>	850 <sup>12)</sup> / 854 <sup>13)</sup> / 885 <sup>12)14)</sup> - 1005 <sup>13)14)</sup>	850 <sup>12)</sup> / 854 <sup>13)</sup> / 885 <sup>12)14)</sup> - 1005 <sup>13)14)</sup>	850 <sup>12)</sup> / 854 <sup>13)</sup> / 885 <sup>12)14)</sup> - 1005 <sup>13)14)</sup>	850 <sup>12)</sup> / 854 <sup>13)</sup> / 885 <sup>12)14)</sup> - 1005 <sup>13)14)</sup>	850 <sup>12)</sup> / 854 <sup>13)</sup> / 885 <sup>12)14)</sup> - 1005 <sup>13)14)</sup>	850 <sup>12)</sup> / 854 <sup>13)</sup> / 885 <sup>12)14)</sup> - 1005 <sup>13)14)</sup>	850 <sup>12)</sup> / 854 <sup>13)</sup> / 885 <sup>12)14)</sup> - 1005 <sup>13)14)</sup>	850 <sup>12)</sup> / 854 <sup>13)</sup> / 885 <sup>12)14)</sup> - 1005 <sup>13)14)</sup>
	Length	mm	2250	2250	2250	2250	2250	2250	2250	2250	2250	2250	2250
		kg	890	971	1156	1329	1340	1453	1552	1660	1743	1798	
Operating weight - chiller	STD	kg	890	971	1156	1329	1340	1453	1552	1660	1743	1798	
	S	kg	993	1074	1259	1432	1443	1556	1655	1763	1846	1901	
Operating weight - heat pump	STD	kg	909	989	1187	1360	1376	1500	1598	1704	1787	1842	
	S	kg	1012	1092	1290	1463	1479	1603	1701	1807	1890	1945	
Operating weight - condenserless unit	STD	kg	770	812	988	1163	1188	1241	1328	1388	1463	1502	
	S	kg	873	915	1091	1266	1291	1344	1431	1491	1566	1605	

## Water connections

Connection type		Victaulic®	Victaulic®	Victaulic®	Victaulic®	Victaulic®	Victaulic®	Victaulic®	Victaulic®	Victaulic®	Victaulic®
Inlet/outlet diameter	Inch	2 1/2	2 1/2	2 1/2	2 1/2	4	4	4	4	4	4

**ECOi-W WQ 524-1604 R - condenserless unit**      **524**      **604**      **704**      **804**      **904**      **1004**      **1104**      **1204**      **1404**      **1604**

## Remote condenser refrigerant connections

Connection type		To be brazed	To be brazed	To be brazed	To be brazed	To be brazed	To be brazed	To be brazed	To be brazed	To be brazed	To be brazed
Inlet diameter	Inch	7/8	7/8	1 1/8	1 1/8	1 1/8	1 1/8	1 1/8	1 1/8	1 1/8	1 1/8
Outlet diameter	Inch	1 1/8	1 1/8	1 3/8	1 3/8	1 5/8	1 5/8	1 5/8	1 5/8	1 5/8	1 5/8

1) According to EN14511 standard: evaporator EWT/LWT 12 °C/7 °C, condenser EWT/LWT 30 °C/35 °C. 2) According to EN14825 standard. 3) ErP compliant: following COMMISSION REGULATION (EU) 2016/2281. 4) Sound levels are at fully loaded conditions. Sound power values refers to ISO 3744 standard. 5) Sound pressures refer to ISO 3744 standard, parallelepiped shape. 6) According to EN14511 standard: evaporator EWT/LWT 10 °C/7 °C, condenser EWT/LWT 40 °C/45 °C. 7) According to EN14511 standard: evaporator EWT/LWT 10 °C/7 °C, condenser EWT/LWT 30 °C/35 °C. 8) ErP compliant: following COMMISSION REGULATION (EU) No 813/2013. 9) According to EN14825 standard - low temperature application (35 °C). 10) According to EN14825 standard - medium temperature application (55 °C). 11) Data refers to evaporator water temperature 12/7 °C and condensing temperature 50 °C. 12) Standard version. 13) S version. 14) Only for handling.





# ECOi-W WSW-N EVO 440-1550 C/H/R - R513A

Water cooled chillers, heat pumps and condenserless units.

Cooling capacity: 410 to 1460 kW.

Heating capacity: 470 to 1650 kW.



## Operating limits

To be confirmed with AC SELECT:

<https://acselect.panasonic.eu/>

ECOi-W WSW-N EVO 440-1550 C - chiller				
Evaporator	Leaving water temperature	Water	°C	From 5 to 15
		Water + glycol	°C	From 0 to 5
		Brine	°C	From -8 to 0
		ΔT	K	From 3 to 7
Condenser	Leaving water temperature	°C	From 25 to 45	
ECOi-W WSW-N EVO 440-1550 H - heat pump				
Evaporator	Leaving water temperature	Water	°C	From 5 to 15
		Water + glycol	°C	From -8 to 5
		ΔT	K	From 3 to 7
Condenser	Leaving water temperature	°C	From 25 to 60	
ECOi-W WSW-N EVO 440-1550 R - condenserless unit				
Evaporator	Leaving water temperature	Water	°C	From 5 to 15
		Water + glycol	°C	From -8 to 5
		ΔT	K	From 3 to 7
Condenser	Condensing temperature	°C	From 30 to 63	

## Accessories and options

Automatic circuit breaker  
 Compressor stepless control  
 Mechanical gauges  
 Power factor corrector capacitors

## The range at a glance

- 3 versions: C (chiller), H (heat pump) and R (condenserless unit)
- 15 sizes
- 2 acoustic options: STD (standard) and S (super low noise)

## Advantages

- High full load performances: EER up to 4,90
- High seasonal performances: SEER up to 6,70
- Compressor optimization (high / low pressure ratio), according application: Maximum benefit in terms of efficiency design
- Electronic expansion device: excellent control of superheating for the best performance at full and partial load and for a safe operation
- New generation of pure counter-current shell and tube evaporators and condensers: maximum efficiency and new levels of competitiveness
- Control platform: modular architecture, compressor envelope integration, corrective actions in border line areas, easy-friendly user interface

## Equipment

- 1/2 refrigerant circuit(s)
- Twin-screw compressors
- Shell and tube evaporator and condenser
- Electronic expansion valve
- Compressor acoustic box (standard for S version)
- Phase sequence control

## Accessories and options

Several communication protocols  
 Soft starter  
 Water filter  
 Water flow switch

## AC SELECT.

Smart and user-friendly the new air conditioning selection program: <https://acselect.panasonic.eu/>





## Technical performance

Power supply	Voltage	V								400	
	Phase									Three phase	
	Frequency	Hz								50	
Size		440	490	570	630	700	770				
ECOi-W WSW-N EVO 440-770 C - chiller	P-	WSWVN0440CA	WSWVN0490CA	WSWVN0570CA	WSWVN0630CA	WSWVN0700CA	WSWVN0770CA				
Cooling capacity <sup>1)</sup>	kW	418,6	471,6	539,3	601,9	664,4	734,6				
Input power <sup>1)</sup>	kW	88,1	101,1	115,1	127,5	144	158,7				
Total heat rejection <sup>1)</sup>	kW	506,7	572,7	654,3	729,4	808,4	893,4				
EER <sup>1)</sup>		4,75	4,67	4,69	4,72	4,61	4,63				
<b>SEER <sup>2)</sup></b>		<b>6,38</b>	<b>6,38</b>	<b>6,52</b>	<b>6,42</b>	<b>6,38</b>	<b>6,38</b>				
$\eta_{s,c}^{2)}$		<b>252</b>	<b>252</b>	<b>258</b>	<b>254</b>	<b>252</b>	<b>252</b>				
Sound power STD / S <sup>3)</sup>	dB(A)	95 / 85	95 / 85	95 / 85	95 / 85	95 / 85	95 / 85				
Sound pressure at 1 m STD / S <sup>4)</sup>	dB(A)	76 / 66	76 / 66	76 / 66	76 / 66	76 / 66	76 / 66				
Size		860	920	990	1070	1130	1220	1280	1400	1550	
ECOi-W WSW-N EVO 860-1550 C - chiller	P-	WSWVN0860CA	WSWVN0920CA	WSWVN0990CA	WSWVN1070CA	WSWVN1130CA	WSWVN1220CA	WSWVN1280CA	WSWVN1400CA	WSWVN1550CA	
Cooling capacity <sup>1)</sup>	kW	825	874,1	936,6	1019,1	1071,8	1159,3	1226,1	1334,6	1457,9	
Input power <sup>1)</sup>	kW	177,2	190,3	201,4	215,7	228,1	243,8	257,9	286,3	319	
Total heat rejection <sup>1)</sup>	kW	1002,2	1064,3	1137,9	1234,7	1299,8	1403,0	1484,0	1620,9	1776,9	
EER <sup>1)</sup>		4,66	4,59	4,65	4,73	4,70	4,76	4,75	4,66	4,57	
<b>SEER <sup>2)</sup></b>		<b>6,41</b>	<b>6,41</b>	<b>6,41</b>	<b>6,42</b>	<b>6,53</b>	<b>6,51</b>	<b>6,44</b>	<b>6,45</b>	<b>6,42</b>	
$\eta_{s,c}^{2)}$		<b>254</b>	<b>253</b>	<b>254</b>	<b>254</b>	<b>258</b>	<b>257</b>	<b>254</b>	<b>255</b>	<b>254</b>	
Sound power STD / S <sup>3)</sup>	dB(A)	98 / 89	98 / 89	98 / 89	98 / 89	98 / 89	98 / 89	98 / 89	98 / 89	98 / 89	
Sound pressure at 1 m STD / S <sup>4)</sup>	dB(A)	79 / 70	79 / 70	79 / 70	79 / 70	79 / 70	79 / 70	79 / 70	79 / 70	79 / 70	
ECOi-W WSW-N EVO 440-770 H - heat pump	P-	WSWVN0440HA	WSWVN0490HA	WSWVN0570HA	WSWVN0630HA	WSWVN0700HA	WSWVN0770HA				
Cooling capacity <sup>1)</sup>	kW	419	479	547	612	673	731				
Input power <sup>1)</sup>	kW	86,5	98	115	132	147	156				
EER <sup>1)</sup>		4,85	4,89	4,75	4,64	4,58	4,69				
Cooling capacity <sup>5)</sup>	kW	365,9	418,9	483,2	541	595,6	646,6				
Input power <sup>5)</sup>	kW	105,2	118,8	141,3	162,1	171,2	191,3				
EER <sup>5)</sup>		3,48	3,53	3,42	3,34	3,48	3,38				
<b>SEER <sup>2)</sup></b>		<b>6,53</b>	<b>6,38</b>	<b>6,4</b>	<b>6,38</b>	<b>6,45</b>	<b>6,6</b>				
$\eta_{s,c}^{2)}$		<b>258</b>	<b>252</b>	<b>253</b>	<b>252</b>	<b>255</b>	<b>261</b>				
Heating capacity <sup>1)</sup>	kW	504	576	661	742	813	887				
COP <sup>1)</sup>		5,83	5,88	5,74	5,62	5,53	5,68				
Heating capacity <sup>5)</sup>	kW	470,3	536,5	621,7	698,6	764,7	835,9				
COP <sup>5)</sup>		4,46	4,52	4,4	4,31	4,47	4,37				
Sound power STD / S <sup>3)</sup>	dB(A)	95 / 85	95 / 85	95 / 85	95 / 85	95 / 85	95 / 85				
Sound pressure at 1 m STD / S <sup>4)</sup>	dB(A)	76 / 66	76 / 66	76 / 66	76 / 66	76 / 66	76 / 66				
ECOi-W WSW-N EVO 860-1550 H - heat pump	P-	WSWVN0860HA	WSWVN0920HA	WSWVN0990HA	WSWVN1070HA	WSWVN1130HA	WSWVN1220HA	WSWVN1280HA	WSWVN1400HA	WSWVN1550HA	
Cooling capacity <sup>1)</sup>	kW	818	882	946	1013	1083	1156	1217	1340	1451	
Input power <sup>1)</sup>	kW	170	183	195	211	227	242	257	297	306	
EER <sup>1)</sup>		4,81	4,83	4,85	4,80	4,78	4,78	4,74	4,52	4,74	
Cooling capacity <sup>5)</sup>	kW	715,5	772	828,1	891,5	958,8	1023,8	1078,2	1186,9	1285,5	
Input power <sup>5)</sup>	kW	210,1	223,4	236,7	257,3	277	298,6	317,4	342,7	377,4	
EER <sup>5)</sup>		3,41	3,46	3,5	3,46	3,46	3,43	3,4	3,46	3,41	
<b>SEER <sup>2)</sup></b>		<b>6,4</b>	<b>6,5</b>	<b>6,4</b>	<b>6,4</b>	<b>6,5</b>	<b>6,48</b>	<b>6,48</b>	<b>6,5</b>	<b>6,7</b>	
$\eta_{s,c}^{2)}$		<b>253</b>	<b>257</b>	<b>253</b>	<b>253</b>	<b>257</b>	<b>256</b>	<b>256</b>	<b>257</b>	<b>265</b>	
Heating capacity <sup>1)</sup>	kW	987	1064	1141	1222	1308	1396	1470	1619	1754	
COP <sup>1)</sup>		5,8	5,83	5,85	5,8	5,77	5,77	5,73	5,46	5,73	
Heating capacity <sup>5)</sup>	kW	923	992,7	1063	1146	1231,8	1315,8	1386,1	1523,8	1654,6	
COP <sup>5)</sup>		4,39	4,44	4,49	4,45	4,45	4,41	4,37	4,45	4,38	
Sound power STD / S <sup>3)</sup>	dB(A)	98 / 89	98 / 89	98 / 89	98 / 89	98 / 89	98 / 89	98 / 89	98 / 89	98 / 89	
Sound pressure at 1 m STD / S <sup>4)</sup>	dB(A)	79 / 70	79 / 70	79 / 70	79 / 70	79 / 70	79 / 70	79 / 70	79 / 70	79 / 70	
ECOi-W WSW-N EVO 440-770 R - condenserless unit	P-	WSWVN0440RA	WSWVN0490RA	WSWVN0570RA	WSWVN0630RA	WSWVN0700RA	WSWVN0770RA				
Cooling capacity <sup>6)</sup>	kW	358,6	405,3	472,7	535,6	586,2	638,1				
Input power <sup>6)</sup>	kW	106,9	120,2	143,4	161,4	174,9	192,6				
Total heat rejection <sup>6)</sup>	kW	465,8	525,8	614,6	694	760,9	828,8				
Sound power STD / S <sup>3)</sup>	dB(A)	95 / 85	95 / 85	95 / 85	95 / 85	95 / 85	95 / 85				
Sound pressure at 1 m STD / S <sup>4)</sup>	dB(A)	76 / 66	76 / 66	76 / 66	76 / 66	76 / 66	76 / 66				
ECOi-W WSW-N EVO 860-1550 R - condenserless unit	P-	WSWVN0860RA	WSWVN0920RA	WSWVN0990RA	WSWVN1070RA	WSWVN1130RA	WSWVN1220RA	WSWVN1280RA	WSWVN1400RA	WSWVN1550RA	
Cooling capacity <sup>6)</sup>	kW	708,9	758,1	817,2	886,2	947,7	1015,0	1075,9	1181,4	1277,8	
Input power <sup>6)</sup>	kW	213,7	226,9	240,7	263,1	284	306,3	325,4	348,4	384,4	
Total heat rejection <sup>6)</sup>	kW	922,3	984,7	1057,4	1147,9	1230,6	1316,3	1395,1	1527,5	1657,7	
Sound power STD / S <sup>3)</sup>	dB(A)	98 / 89	98 / 89	98 / 89	98 / 89	98 / 89	98 / 89	98 / 89	98 / 89	98 / 89	
Sound pressure at 1 m STD / S <sup>4)</sup>	dB(A)	79 / 70	79 / 70	79 / 70	79 / 70	79 / 70	79 / 70	79 / 70	79 / 70	79 / 70	

1) According to EN14511 standard: evaporator EWT/LWT 12 °C/7 °C, condenser EWT/LWT 30 °C/35 °C. 2) ErP compliant: following COMMISSION REGULATION (EU) 2016/2281 and according to EN14825 standard. 3) Sound levels are at fully loaded conditions. Sound power values refers to ISO 3744 standard. 4) Sound pressures refer to ISO 3744 standard, parallelepiped shape. 5) According to EN14511 standard: evaporator EWT/LWT 10 °C/7 °C, condenser EWT/LWT 40 °C/45 °C. 6) Conditions: evaporator EWT/LWT 12 °C/7 °C, condensing Temperature 49 °C.





## Physical features

<b>ECOi-W WSW-N EVO 440-770 C - chiller</b>			<b>440</b>	<b>490</b>	<b>570</b>	<b>630</b>	<b>700</b>	<b>770</b>			
Dimension	Height	mm	1650	1650	1650	1650	1650	1650			
	Height S	mm	1750	1750	1750	1750	1750	1750			
	Width	mm	1350	1350	1350	1350	1350	1350			
	Length	mm	4250	4250	4210	4210	4180	4180			
Operating weight	STD	kg	2690	2700	2875	3003	3472	3521			
	S	kg	2884	2894	3069	3197	3666	3715			
<b>Water connections</b>											
Connection type	Evaporator		Victaulic®	Victaulic®	Victaulic®	Victaulic®	Victaulic®	Victaulic®	Victaulic®	Victaulic®	
Inlet/outlet diameter		Inch	6	6	6	6	8	8			
Connection type	Condenser		Female gas threaded	Female gas threaded	Female gas threaded	Female gas threaded	Female gas threaded	Female gas threaded	Female gas threaded	Female gas threaded	
Inlet/outlet diameter		Inch	4	4	5	5	5	5			
<b>ECOi-W WSW-N EVO 860-1550 C - chiller</b>			<b>860</b>	<b>920</b>	<b>990</b>	<b>1070</b>	<b>1130</b>	<b>1220</b>	<b>1280</b>	<b>1400</b>	<b>1550</b>
Dimension	Height	mm	1710	1710	1710	1710	1710	1710	1710	1710	
	Height S	mm	1780	1780	1780	1780	1780	1780	1780	1780	
	Width	mm	1520	1520	1520	1520	1520	1520	1520	1520	
	Length	mm	4510	4510	4600	4650	4650	4650	4650	5350	5350
	Length S	mm	4510	4510	4690	4690	4690	4690	4690	5400	5400
Operating weight	STD	kg	5000	5010	5642	5818	6012	6077	6124	6698	6752
	S	kg	5388	5398	6030	6206	6400	6465	6512	7086	7140
<b>Water connections</b>											
Connection type	Evaporator		Victaulic®	Victaulic®	Victaulic®	Victaulic®	Victaulic®	Victaulic®	Victaulic®	Victaulic®	
Inlet/outlet diameter		Inch	8	8	10	10	10	10	10	10	
Connection type	Condenser		Victaulic®	Victaulic®	Victaulic®	Victaulic®	Victaulic®	Victaulic®	Victaulic®	Victaulic®	
Inlet/outlet diameter	Condenser	Inch	4 / 4	4 / 4	5 / 5	5 / 5	5 / 5	5 / 5	5 / 5	5 / 5	
<b>ECOi-W WSW-N EVO 440-770 H - heat pump</b>			<b>440</b>	<b>490</b>	<b>570</b>	<b>630</b>	<b>700</b>	<b>770</b>			
Dimension	Height	mm	1650	1650	1650	1650	1650	1650			
	Height S	mm	1750	1750	1750	1750	1750	1750			
	Width	mm	1450	1450	1450	1450	1450	1450			
	Length	mm	4590	4590	4630	4630	4320	4560			
Operating weight	STD	kg	3055	3186	3277	3197	4027	3824			
	S	kg	3249	3380	3471	3491	4221	4017			
<b>Water connections</b>											
Connection type	Evaporator		Victaulic®	Victaulic®	Victaulic®	Victaulic®	Victaulic®	Victaulic®	Victaulic®	Victaulic®	
Inlet/outlet diameter		Inch	6	6	6	6	8	8			
Connection type	Condenser		Victaulic®	Victaulic®	Victaulic®	Victaulic®	Victaulic®	Victaulic®	Victaulic®	Victaulic®	
Inlet/outlet diameter		Inch	4	4	5	5	5	5			
<b>ECOi-W WSW-N EVO 860-1550 H - heat pump</b>			<b>860</b>	<b>920</b>	<b>990</b>	<b>1070</b>	<b>1130</b>	<b>1220</b>	<b>1280</b>	<b>1400</b>	<b>1550</b>
Dimension	Height	mm	1680	1680	1680	1680	1680	1680	1680	1710	1710
	Height S	mm	1780	1780	1780	1780	1780	1780	1780	1780	1780
	Width	mm	1520	1520	1520	1520	1520	1520	1520	1580	1580
	Length	mm	5110	5110	5100	5100	5000	5000	5000	5300	5300
	Length S	mm	5130	5130	5120	5120	5020	5020	5020	5320	5320
Operating weight	STD	kg	5818	5841	6119	6545	6768	6807	6844	7991	8071
	S	kg	6205	6229	6506	6932	7155	7194	7232	8378	8458
<b>Water connections</b>											
Connection type	Evaporator		Victaulic®	Victaulic®	Victaulic®	Victaulic®	Victaulic®	Victaulic®	Victaulic®	Victaulic®	
Inlet/outlet diameter		Inch	8	8	10	10	10	10	10	10	
Connection type	Condenser		Victaulic®	Victaulic®	Victaulic®	Victaulic®	Victaulic®	Victaulic®	Victaulic®	Victaulic®	
Inlet/outlet diameter		Inch	4 / 4	4 / 4	4 / 4	4 / 5	5 / 5	5 / 5	5 / 5	5 / 5	

**Physical features**

<b>ECOi-W WSW-N EVO 440-770 R - condenserless unit</b>			<b>440</b>	<b>490</b>	<b>570</b>	<b>630</b>	<b>700</b>	<b>770</b>			
Dimension	Height	mm	1650	1650	1650	1650	1650	1650			
	Height S	mm	1750	1750	1750	1750	1750	1750			
	Width	mm	1350	1350	1350	1350	1350	1350			
	Length	mm	3620	3620	4210	4210	4180	4180			
Operating weight	STD	kg	2302	2312	2456	2476	2952	2992			
	S	kg	2496	2506	2650	2670	3146	3186			
<b>Water connections (evaporator)</b>											
Connection type			Victaulic®	Victaulic®	Victaulic®	Victaulic®	Victaulic®	Victaulic®	Victaulic®		
Inlet/outlet diameter		Inch	6	6	6	6	8	8			
<b>Remote condenser refrigerant connections</b>											
Connection type			To be brazed	To be brazed	To be brazed	To be brazed	To be brazed	To be brazed	To be brazed		
Inlet diameter circuit 1		Inch	1 5/8	1 5/8	2 1/8	2 1/8	2 1/8	2 1/8			
Outlet diameter circuit 1		Inch	3 1/8	3 1/8	3 5/8	3 5/8	4 1/8	4 1/8			
<b>ECOi-W WSW-N EVO 860-1550 R - condenserless unit</b>			<b>860</b>	<b>920</b>	<b>990</b>	<b>1070</b>	<b>1130</b>	<b>1220</b>	<b>1280</b>	<b>1400</b>	<b>1550</b>
Dimension	Height	mm	1710	1710	1710	1710	1710	1710	1710	1710	
	Height S	mm	1770	1770	1770	1770	1770	1770	1770	1770	
	Width	mm	1520	1520	1520	1520	1520	1520	1520	1520	
	Length	mm	4400	4400	4600	4650	4650	4650	4650	5350	5350
	Length S	mm	4650	4650	4650	4650	4650	4650	4650	5400	5400
Operating weight	STD	kg	4804	4814	4998	5071	5131	5170	5190	5596	5676
	S	kg	5191	5201	5385	5458	5518	5557	5577	5983	6063
<b>Water connections (evaporator)</b>											
Connection type			Victaulic®	Victaulic®	Victaulic®	Victaulic®	Victaulic®	Victaulic®	Victaulic®	Victaulic®	
Inlet/outlet diameter		Inch	8	8	10	10	10	10	10	10	
<b>Remote condenser refrigerant connections</b>											
Connection type			To be brazed	To be brazed	To be brazed	To be brazed	To be brazed	To be brazed	To be brazed	To be brazed	
Inlet diameter circuit 1		Inch	1 5/8	1 5/8	1 5/8	2 1/8	2 1/8	2 1/8	2 1/8	2 1/8	
Outlet diameter circuit 1		Inch	3 1/8	3 1/8	3 1/8	3 1/8	3 1/8	3 1/8	3 1/8	4 1/8	4 1/8
Inlet diameter circuit 2		Inch	1 5/8	1 5/8	1 5/8	2 1/8	2 1/8	2 1/8	2 1/8	2 1/8	
Outlet diameter circuit 2		Inch	3 1/8	3 1/8	3 1/8	3 1/8	3 1/8	3 1/8	3 1/8	4 1/8	4 1/8

## Fan coil units

A large range of fan coil units dedicated to energy savings, comfort, flexibility and quality.



### Energy savings and comfort

#### Low consumption solutions.

- High efficiency fan motor
- High level of energy performance

#### Silence.

- Optimised fan speed staging
- Reinforced acoustic insulation
- Profiled air diffusers

### Flexibility and quality





#### Many factory-mounted options.

- Control
- Valve
- Air diffusion
- Condensate drain pump ...

#### Products fully customisable to satisfy your requirements.

- Choice of service side for hydraulic and electrical connections
- Version with or without cabinet ...

# Quick selection guide - Fan coil units

Page	Size	Cooling and heating capacity <sup>1)</sup> (kW)	NR sound levels (at MS) <sup>1)2)</sup>	Air flow <sup>1)</sup> (m <sup>3</sup> /h)	Pressure (Pa)	Fan	Dimension <sup>3)</sup> LxWxH (mm)
<b>P. 526</b> 	10	3,2 3,4	33	108-417	—	AC/EC	766 x 225 x 477
	20	2,1 2,5	33	98-413	—	AC/EC	766 x 225 x 477
	30	1,8 2,7	36	119-345	—	AC/EC	951 x 225 x 477
	40	4,2 4,5	30	170-678	—	AC/EC	1136 x 225 x 477
	50	5,0 5,2	37	203-816	—	AC/EC	1321 x 225 x 477
	60	5,2 5,8	40	245-912	—	AC/EC	1506 x 225 x 477
	70	6,6 7,2	40	350-1050	—	AC/EC	1319 x 225 x 575
	80	8,4 8,5	42	500-1063	—	EC	1506 x 225 x 575
<b>P. 530</b> 	20	2,4 2,7	27	360-659	—	AC/EC	595 x 595 x 341
	30	4,0 3,7	30	320-734	—	AC/EC	595 x 595 x 341
	40	4,7 5,3	34	486-900	—	AC/EC	595 x 595 x 341
	50	6,1 6,8	26	529-979	—	AC/EC	849 x 849 x 358
	60	7,2 8,5	32	500-1159	—	AC/EC	849 x 849 x 358
	70	9,6 11,0	38	601-1598	—	AC/EC	849 x 849 x 358
<b>P. 534</b> 	7	1,7 1,7	36	282-360	—	AC	845 x 180 x 275
	9	2,5 2,8	39	367-551	—	AC	845 x 180 x 275
	18	3,6 4,1	43	532-680	—	AC	940 x 200 x 298
	22	4,0 4,5	46	617-850	—	AC	940 x 200 x 298
<b>P. 536</b> 	10	1,5 1,8	30	48-161	0-70	EC	633 x 631 x 223
	15	2,1 2,6	32	255-491	0-90	EC	733 x 631 x 223
	20	2,7 2,6	35	360-599	0-90	EC	833 x 631 x 223
	25	3,2 3,4	34	448-642	0-90	EC	933 x 631 x 223
	30	4,8 5,0	34	300-1068	0-90	EC	933 x 631 x 223
	40	6,7 7,1	34	347-1293	0-90	EC	1233 x 653 x 223
	40	6,7 7,1	34	347-1293	0-90	EC	1233 x 653 x 223
<b>P. 538</b> 	7	5,6 6,7	34	703-1125	0-110	AC/EC	1200 x 698 x 250
	15	13,3 15,5	40	960-2830	0-200	AC/EC	1380 x 798 x 375
	18	13,9 18,0	40	960-2830	0-200	AC/EC	1380 x 798 x 375
	21	17,0 17,8	40	960-2830	0-200	AC/EC	1380 x 798 x 375
	24	21,2 24,3	44	2040-3451	0-220	AC/EC	1500 x 798 x 450
	24	21,2 24,3	44	2040-3451	0-220	AC/EC	1500 x 798 x 450
	27	24,8 25,0	44	2040-3451	0-220	AC/EC	1500 x 798 x 450

1) Data for fan coil comfort, cassette and duct EC fan 2-pipe version. Data for fan coil high static duct AC fan / 2-pipe version. 2) Informative data, considering an hypothetical sound attenuation of the room and installation of 9 dB(A) [21 dB(A) for fan coil high static duct]. 3) Fan coil comfort: with cabinet / without feet. Fan coil cassette: casing + IRYS COANDA 360 diffuser. Fan coil duct and high static duct: configuration: rectangular return and discharge.

# Fan coil comfort AC fan

Fan coil floor and ceiling units with cooling and heating.

Cooling capacity: 0,6 to 6,9 kW.

Heating capacity: 0,6 to 7,4 kW.



Optional controller.  
WRC remote control.



Optional controller.  
SRC - mini BMS  
controller.



Optional controller.  
Electronic controller  
TControl POD glass.



Optional controller.  
Electronic controller  
TControl EASY 3S.



Optional controller.  
Wired remote  
controller with  
touch control.  
PAW-FC-907AC



Optional controller.  
Wired remote  
controller.  
PAW-FC-903AC



Optional controller.  
Advanced wired  
remote controller.  
PAW-FC-RC1

+ SEE PAGE 542 FOR MORE DETAILS ABOUT FAN COIL CONTROLLERS

## Operating limits

Entering water temperature (without glycol).

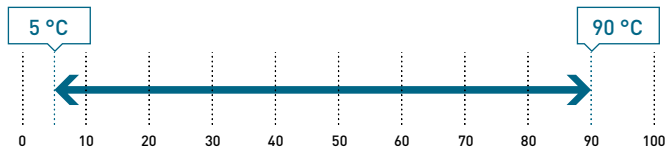

Indoor air temperature.

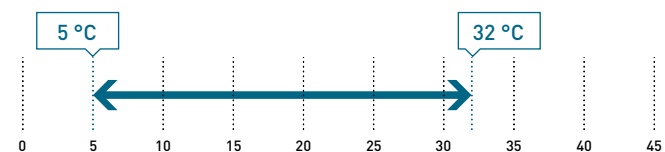

## The range at a glance

- Versions: 2-pipes, 2-pipes + electric heater and 4-pipes
- 7 sizes
- 5-speed AC fan - standard factory set speeds: S1,S3,S5
- Air flow from 94 to 1064 m<sup>3</sup>/h
- Configuration: universal installation units (vertical or horizontal) with or without cabinet
- Left or right water connections
- Many air inlet/outlet configurations
- G2 air filter (G3 as an option)

## Advantages

- Silent units
- New casing design for an increased robustness
- Harmonious and aesthetic RAL 9003 painted cabinet
- Valves, condensate drain pan and drain pump factory mounted
- 100% factory tested

## Accessories and options

2 way or 3 way valves

4-pipes kit (additional coil)

Circuit breakers

Drain pump

Electric heaters (from 500 W to 2500 W)

Feet with/without grid

Fuse holders

G3 filter

Horizontal or vertical drain guard (with valve)

Many air inlet/outlet configurations

Mechanical sensor for automatic change over

Modbus communication board for Plogic

MRC/WRC/BRC: remote controls for Plogic

Other speeds configuration (standard factory set speeds: S1,S3,S5)

SRC - mini BMS controller

Suspension kit

Plogic controller (other electromechanical or electronic control systems also available)

TControl EASY 3S and TControl POD glass controllers (other electromechanical or electronic control systems also available)

## AC SELECT.

Smart and user-friendly the new air conditioning selection program: <https://acselect.panasonic.eu/>



## Technical features

Fan coil comfort AC fan		P-FC10		P-FC20		P-FC30		P-FC40		P-FC50		P-FC60		P-FC70		
		S1/S3/S5 <sup>1)</sup>		S1/S3/S5 <sup>1)</sup>		S1/S3/S5 <sup>1)</sup>		S1/S3/S5 <sup>1)</sup>		S1/S3/S5 <sup>1)</sup>		S1/S3/S5 <sup>1)</sup>		S1/S3/S5 <sup>1)</sup>		
<b>2-pipes</b>																
Total cooling capacity <sup>2)</sup>	kW	0,66/1,00/1,45	0,61/0,96/1,38	0,95/1,88/2,37	1,14/2,28/3,02	1,71/3,16/4,64	2,57/4,33/5,53	3,24/5,84/6,91								
Sensible capacity <sup>2)</sup>	kW	0,48/0,77/1,05	0,43/0,70/1,02	0,78/1,44/1,80	0,83/1,66/2,23	1,24/2,23/3,27	1,81/3,14/4,25	2,26/4,11/4,85								
Water flow <sup>2)</sup>	l/h	114/172/250	105/165/238	164/324/408	196/393/520	295/544/799	443/746/953	558/1006/1190								
Water pressure drop <sup>2)3)</sup>	kPa	9,17/19,5/39,1	2,65/4,62/7,43	5,8/17,6/26,3	5,0/15,6/25,6	7,5/22,8/47,1	12,6/33,9/54,4	4,4/13,9/19,4								
Heating capacity <sup>4)</sup>	kW	0,63/1,18/1,71	0,63/1,03/1,53	1,00/1,86/2,49	1,14/2,28/3,18	1,79/3,47/4,81	2,45/4,22/5,63	3,45/6,27/7,41								
Water flow <sup>4)</sup>	l/h	109/203/295	109/177/264	172/320/429	196/393/548	308/598/829	422/727/970	594/1080/1276								
Water pressure drop <sup>2)4)</sup>	kPa	5,9/17,3/33,8	2,76/5,06/8,54	5,8/16,2/27,0	5,0/15,6/28,1	6,1/20,7/38,5	18,6/52,4/91,4	4,9/16,0/22,3								
<b>4-pipes</b>																
Total cooling capacity <sup>2)</sup>	kW	0,63/0,88/1,24	0,87/1,34/1,73	0,91/1,80/2,28	0,98/2,14/2,85	1,57/2,88/4,13	2,60/4,39/5,61	3,17/5,62/6,58								
Sensible capacity <sup>2)</sup>	kW	0,46/0,67/0,91	0,65/1,02/1,36	0,75/1,39/1,74	0,71/1,57/2,10	1,14/2,04/2,92	1,82/3,18/4,28	2,21/3,96/4,62								
Water flow <sup>2)</sup>	l/h	109/152/214	150/231/298	157/310/393	169/369/491	270/496/711	448/756/966	546/968/1133								
Water pressure drop <sup>2)3)</sup>	kPa	7,6/13,9/26,3	2,33/4,44/6,64	2,8/8,6/13,1	5,8/20,5/33,6	3,9/11,6/22,8	10,2/27,7/44,5	5,3/16,2/22,1								
Heating capacity <sup>5)</sup>	kW	0,63/1,00/1,41	1,00/1,40/1,68	1,28/1,81/2,13	1,22/2,21/2,85	2,01/3,19/4,08	2,71/4,24/5,33	3,65/5,00/5,90								
Water flow <sup>5)</sup>	l/h	54/86/121	86,1/121/145	110/156/183	105/190/245	173/275/351	233/365/459	314/431/508								
Water pressure drop <sup>2)5)</sup>	kPa	1,2/2,1/3,3	1,15/2,2/3,12	2,8/4,7/6,1	5,1/13,9/21,8	5,7/12,5/19,4	11,6/24,8/37	35,4/60,7/81,2								
<b>Sound levels</b>																
Sound power	2-pipes	dB(A)	33/40/49	31/43/50	30/45/52	30/44/51	34/43/56	38/51/58	43/56/61							
	4-pipes	dB(A)	33/40/49	31/43/50	30/45/52	30/44/51	34/46/56	38/51/58	43/56/61							
Sound pressure <sup>6)</sup>	2-pipes	dB(A)	24/31/40	22/34/41	21/36/43	21/35/42	25/37/47	29/42/49	34/47/52							
	4-pipes	dB(A)	24/31/40	22/34/41	21/36/43	21/35/42	25/37/47	29/42/49	34/47/52							
NR <sup>6)</sup>	2-pipes		19/26/35	17/29/36	16/31/38	16/30/37	20/32/42	24/37/44	29/42/47							
	4-pipes		19/26/35	17/29/36	16/31/38	16/30/37	20/32/42	24/37/44	29/42/47							
<b>Ventilation</b>																
Number of fans			1	1	1	2	2	2	2							
Air flow	2-pipes	m <sup>3</sup> /h	94/190/283	68/104/196	138/274/390	173/357/499	253/486/716	350/640/933	480/893/1064							
	4-pipes	m <sup>3</sup> /h	95/168/253	89/161/241	132/263/369	148/335/467	242/466/671	334/614/885	470/859/1012							
Filter			G2	G2	G2	G2	G2	G2	G2							
<b>Electrical data</b>																
Power supply	Voltage	V	230	230	230	230	230	230	230							
	Phase		Single phase	Single phase	Single phase	Single phase	Single phase	Single phase	Single phase							
	Frequency	Hz	50/60	50/60	50/60	50/60	50/60	50/60	50/60	50/60						
Consumption	2-pipes	W	13/24/36	13/18/31	16/37/45	15/37/56	28/55/72	37/75/105	53/100/147							
	4-pipes	W	13/24/36	11/18/28	16/37/44	15/37/55	28/54/70	37/74/104	53/99/145							
Electric heater	W	500	500	500/1000	1250	1250/2500	1250/2500	1250/2500								
<b>Water connections</b>																
Connection type			Female gas threaded	Female gas threaded	Female gas threaded	Female gas threaded	Female gas threaded	Female gas threaded	Female gas threaded							
2 or 4-pipes	Cooling	Inch	½	½	½	½	½	½	½							
4-pipes	Heating	Inch	½	½	½	½	½	½	½							
<b>Dimension</b>																
With cabinet - without feet	LxWxH	mm	766x225x477	766x225x477	951x225x477	1136x225x477	1321x225x477	1506x225x477	1319x225x575							
Without cabinet	LxWxH	mm	570x220x430	570x220x430	753x220x430	938x220x430	1122x220x430	1307x220x430	1121x220x530							
<b>Weight</b>																
With cabinet	2-pipes	kg	19	19	22	27	30	35	35							
	4-pipes	kg	20	20	23	29	32	37	37							
Without cabinet	2-pipes	kg	13	13	15	20	22	26	27							
	4-pipes	kg	14	14	16	22	24	28	29							

## Energy efficiency class<sup>7)</sup>

Fan coil comfort AC fan		FCEER	A to E	E	E	D	D	D	D	D
2-pipes	FCEER	A to E	E	E	D	D	D	D	D	D
	FCCOP	A to E	E	E	E	E	E	E	E	E
4-pipes	FCEER	A to E	E	D	D	D	E	D	D	D
	FCCOP	A to E	E	D	D	D	E	E	E	E

1) Fan standard factory set speeds. 2) According to Eurovent standard. Air: 27 °C DB/19 °C WB, chilled water: 7 °C/12 °C. 3) Pressure loss by corresponding nominal flow. 4) According to Eurovent standard. Air: 20 °C, hot water: 45 °C/40 °C. 5) According to Eurovent standard. Air: 20 °C, hot water: 65 °C/55 °C. 6) Informative data, considering an hypothetical sound attenuation of the room and installation of 9 dB(A). 7) According to Eurovent. \* Standard configuration with left hand hydraulic connection. G2 air filter included as standard.



ErP compliant following COMMISSION REGULATION (EU) 2016/2281.



# Fan coil comfort EC fan

Fan coil floor and ceiling units with cooling and heating.

Cooling capacity: 0,5 to 9,1 kW.

Heating capacity: 0,6 to 12,9 kW.



Optional controller.  
WRC remote control.



Optional controller.  
SRC - mini BMS  
controller.



Optional controller.  
Electronic controller  
TControl POD glass.



Optional controller.  
Electronic controller  
TControl EASY 3S.



Optional controller.  
Wired remote controller  
with touch control.  
PAW-FC-907EC



Optional controller.  
Wired remote controller.  
PAW-FC-903EC

+ SEE PAGE 542 FOR MORE DETAILS ABOUT FAN COIL CONTROLLERS

## Operating limits

Entering water temperature (without glycol).

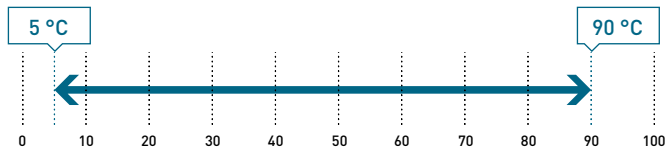

Indoor air temperature.

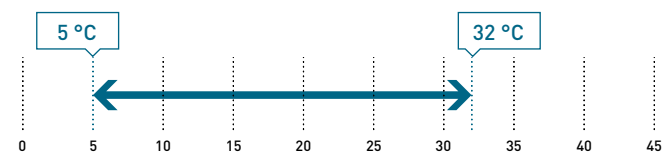

## The range at a glance

- Versions: 2-pipes, 2-pipes + electric heater and 4-pipes
- 8 sizes
- Low energy consumption EC fan: 100% controllable via a 0-10 V signal or 3 operating speeds
- Air flow from 91 to 1548 m<sup>3</sup>/h
- Configuration: universal installation units (vertical or horizontal) with or without cabinet
- Left or right water connections
- Many air inlet/outlet configurations
- G2 air filter (G3 as an accessory)

## Advantages

- Excellent performances: FCEER and FCCOP up to "A"
- Silent units
- New casing design for an increased robustness
- Harmonious and aesthetic RAL 9003 painted cabinet
- Valves, condensate drain pan and drain pump factory mounted
- 100% factory tested

## Accessories and options

2 way or 3 way valves
4-pipes kit (additional coil)
Circuit breakers
Drain pump
Ecospeed card for EC fans
Electric heaters (from 500 W to 2500 W)
Feet with/without grid
Fuse holders
G3 filter
Horizontal or vertical drain guard (with valve)
Many air inlet/outlet configurations
Electromechanical sensor for automatic change over
Modbus communication board for Plogic
MRC/WRC/BRC: remote controls for Plogic
Other speeds configuration (standard factory set speeds in technical features table)
SRC - mini BMS controller
Suspension kit
Plogic controller (other electromechanical or electronic control systems also available)
TControl EASY 3S and TControl POD glass controllers (other electromechanical or electronic control systems also available)

## AC SELECT.

Smart and user-friendly the new air conditioning selection program: <https://acselect.panasonic.eu/>



## Technical features

Fan coil comfort EC fan		P-FC10		P-FC20		P-FC30		P-FC40		P-FC50		P-FC60		P-FC70		P-FC80		
		2V/5V/10V <sup>1)</sup>		2V/5V/10V <sup>1)</sup>		2V/6V/10V <sup>1)</sup>		2V/5V/10V <sup>1)</sup>		2V/7V/10V <sup>1)</sup>		2V/7V/10V <sup>1)</sup>		4V/8V/10V <sup>1)</sup>		3V/4,1V/6,4V <sup>1)</sup>		
<b>2-pipes</b>																		
Total cooling capacity <sup>2)</sup>	kW	0,59/1,16/1,96	0,61/1,31/2,12	0,67/1,41/1,83	1,34/2,93/4,19	1,34/3,57/4,98	1,98/4,45/5,24	2,55/5,56/6,55	4,59/6,13/8,36									
Sensible capacity <sup>2)</sup>	kW	0,48/1,00/1,76	0,47/1,06/1,72	0,47/1,04/1,34	0,95/2,10/3,00	1,05/2,70/3,70	1,35/3,51/4,02	1,91/4,10/4,96	3,32/4,51/6,28									
Water flow <sup>2)</sup>	l/h	102/200/338	105/226/365	141/336/505	231/505/722	231/615/858	341/767/903	439/958/1128	791/1056/1440									
Water pressure drop <sup>2) 3)</sup>	kPa	7,5/25,7/69,5	1,4/4,3/9,3	5,9/21,8/42,9	6,4/24,3/46,3	4,9/28,7/53,9	7,8/35,8/49,0	2,7/12,6/17,5	14,1/21,4/37,6									
Heating capacity <sup>4)</sup>	kW	0,67/1,30/2,31	0,68/1,53/2,52	0,80/1,72/2,66	1,11/2,48/4,46	1,38/3,89/5,19	1,95/4,93/5,82	3,05/5,81/7,17	4,21/5,80/8,43									
Water flow <sup>4)</sup>	l/h	115/224/398	117/264/434	138/296/458	191/427/768	238/670/894	336/849/1002	525/1001/1235	798/1101/1598									
Water pressure drop <sup>2) 4)</sup>	kPa	6,5/20,6/59,1	1,7/5,5/12,4	4,1/14,2/30,4	4,8/18,1/51,9	3,8/25,7/44,6	12,2/70,7/97,5	3,9/13,8/20,9	14,4/23,1/45,6									
<b>4-pipes</b>																		
Total cooling capacity <sup>2)</sup>	kW	0,51/1,02/1,80	0,57/1,20/2,18	0,75/1,84/2,93	1,03/2,20/3,52	1,17/3,45/4,39	1,69/3,90/4,69	2,44/4,88/6,06	4,44/5,86/9,07									
Sensible capacity <sup>2)</sup>	kW	0,41/0,87/1,60	0,43/0,96/1,76	0,55/1,44/2,28	0,73/1,57/2,58	0,92/2,61/3,28	1,12/3,05/3,63	1,83/3,61/4,53	3,20/4,31/6,84									
Water flow <sup>2)</sup>	l/h	87,8/176/310	98,2/207/376	129/317/505	177/379/606	202/594/756	291/672/808	420/841/1044	765/1009/1562									
Water pressure drop <sup>2) 3)</sup>	kPa	5,2/18,3/53,4	1,3/3,8/9,7	4,0/13,7/28,0	9,3/27,8/58,9	2,3/16,2/25,6	4,6/22,0/31,4	3,2/12,3/18,8	18,8/30,6/67,2									
Heating capacity <sup>5)</sup>	kW	0,61/1,13/1,87	0,79/1,33/2,09	1,41/2,01/2,77	1,57/2,49/3,62	2,18/3,34/4,10	1,81/4,05/4,81	3,45/4,67/5,53	5,74/7,99/12,90									
Water flow <sup>5)</sup>	l/h	52,5/97,3/161	68/115/180	121/173/239	135/214/312	188/288/353	156/349/414	297/402/476	494/688/1111									
Water pressure drop <sup>2) 5)</sup>	kPa	1,1/2,4/4,8	<1/2,0/4,8	7,9/12,3/18,6	10,9/22,2/41,1	6,5/13,6/19,6	16,1/45,3/57,5	32,2/53,9/72,4	19,2/34,5/83,1									
<b>Sound levels</b>																		
Sound power	2-pipes	dB(A)	34/47/60	34/47/60	31/50/59	29/44/52	30/51/57	32/54/58	40/54/59	51/56/64								
	4-pipes	dB(A)	34/47/60	34/47/60	31/50/59	29/44/56	30/51/57	32/54/58	40/54/59	51/56/64								
Sound pressure <sup>6)</sup>	2-pipes	dB(A)	25/38/51	25/38/51	22/41/50	20/35/43	21/42/48	23/45/49	31/45/50	42/47/55								
	4-pipes	dB(A)	25/38/51	25/38/51	22/41/50	20/35/43	21/42/48	23/45/49	31/45/50	42/47/55								
NR <sup>6)</sup>	2-pipes		20/33/46	20/33/46	17/36/45	15/30/38	16/37/43	18/40/44	26/40/45	37/42/50								
	4-pipes		20/33/46	20/33/46	17/36/45	15/30/38	16/37/43	18/40/44	26/40/45	37/42/50								
<b>Ventilation</b>																		
Number of fans			1	1	1	2	2	2	2	3								
Air flow	2-pipes	m <sup>3</sup> /h	108/228/417	98/234/413	119/257/345	170/412/678	203/577/816	245/737/912	350/850/1050	500/680/1063								
	4-pipes	m <sup>3</sup> /h	91/199/379	84/200/380	123/297/540	148/298/524	185/587/755	205/668/845	329/798/989	660/884/1548								
Filter			G2	G2	G2	G2	G2	G2	G2	G2								
<b>Electrical data</b>																		
Power supply	Voltage	V	230	230	230	230	230	230	230	230								
	Phase		Single phase	Single phase	Single phase	Single phase	Single phase	Single phase	Single phase	Single phase								
	Frequency	Hz	50/60	50/60	50/60	50/60	50/60	50/60	50/60	50/60								
Consumption	2-pipes	W	7/12/41	7/13/41	6/16/42	2/13/43	4/23/46	4/30/54	11/44/77	23/42/108								
	4-pipes	W	7/12/39	7/13/40	6/14/40	2/11/39	4/23/44	4/28/52	11/43/75	22/41/116								
Electric heater	W	500	500	500/1000	1250	1250/2500	1250/2500	1250/2500	1250/2500									
<b>Water connections</b>																		
Connection type			Female gas threaded	Female gas threaded	Female gas threaded	Female gas threaded	Female gas threaded	Female gas threaded	Female gas threaded	Female gas threaded								
2 or 4-pipes	Cooling	Inch	½	½	½	½	½	½	½	¾								
4-pipes	Heating	Inch	½	½	½	½	½	½	½	½								
<b>Dimension</b>																		
With cabinet - without feet	L x W x H	mm	766 x 225 x 477	766 x 225 x 477	951 x 225 x 477	1136 x 225 x 477	1321 x 225 x 477	1506 x 225 x 477	1319 x 225 x 575	1506 x 225 x 575								
Without cabinet	L x W x H	mm	570 x 220 x 430	570 x 220 x 430	753 x 220 x 430	938 x 220 x 430	1122 x 220 x 430	1307 x 220 x 430	1121 x 220 x 530	1316 x 220 x 530								
<b>Weight</b>																		
With cabinet	2-pipes	kg	19	19	22	27	30	35	35	47								
	4-pipes	kg	20	20	23	29	32	37	37	49								
Without cabinet	2-pipes	kg	13	13	15	20	22	26	27	38								
	4-pipes	kg	14	14	16	22	24	28	29	40								

Energy efficiency class<sup>7)</sup>

Fan coil comfort EC fan		FCEER		A to E		C		C		B		A		A		B		B	
2-pipes	FCCOP	A to E	D	C	C	B	A	A	A	B	B	B	B	B	B	B	B	B	C
	FCEER	A to E	C	C	B	A	B	B	B	B	B	B	B	B	B	B	B	B	A
4-pipes	FCCOP	A to E	C	C	B	A	B	B	B	B	B	B	B	B	B	B	B	B	A
	FCEER	A to E	C	C	B	A	B	B	B	B	B	B	B	B	B	B	B	B	A

1) Fan standard factory set speeds (voltage). 2) According to Eurovent standard. Air: 27 °C DB/19 °C WB, chilled water: 7 °C/12 °C. 3) Pressure loss by corresponding nominal flow. 4) According to Eurovent standard. Air: 20 °C, hot water: 45 °C/40 °C. 5) According to Eurovent standard. Air: 20 °C, hot water: 65 °C/55 °C. 6) Informative data, considering a hypothetical sound attenuation of the room and installation of 9 dB(A). 7) According to Eurovent. \* Standard configuration with left hand hydraulic connection. G2 air filter included as standard.



ErP compliant following COMMISSION REGULATION (EU) 2016/2281.



# Fan coil cassette AC fan

Fan coil cassette units with cooling and heating.

Cooling capacity: 1,3 to 8,6 kW.

Heating capacity: 1,1 to 12,8 kW.



Optional controller. WRC remote control.



Optional controller. SRC - mini BMS controller.



Optional controller. Electronic controller TControl POD glass.



Optional controller. Electronic controller TControl EASY 3S.



Optional controller. Wired remote controller with touch control. PAW-FC-907AC



Optional controller. Wired remote controller. PAW-FC-903AC



Optional controller. Advanced wired remote controller. PAW-FC-RC1

+ SEE PAGE 542 FOR MORE DETAILS ABOUT FAN COIL CONTROLLERS

## Operating limits

Entering water temperature (without glycol).

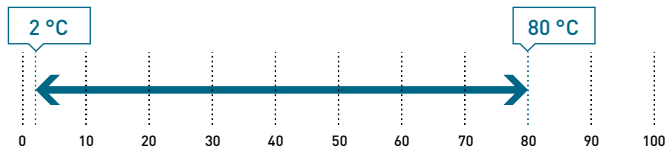

Indoor air temperature.

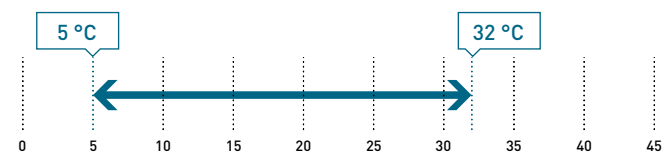

## The range at a glance

- Versions: 2-pipes, 2-pipes + electric heater and 4-pipes
- 6 sizes
- 3-speed AC fan
- Air flow from 360 to 1447 m<sup>3</sup>/h
- Integrated condensate drain pump
- G1 cleanable air filter

## Advantages

- Aesthetic and IRYS COANDA design diffusers with strong coanda effect
- Silent units
- Easy installation and maintenance: all connections on the same side. Electrical box and valves outside of the unit
- Low built-in-height
- Perfect integration into standard 600 x 600 ceiling tiles\*
- Valves and drain pump factory mounted

\* From 20 to 40 with IRYS COANDA diffusers.

## IRYS COANDA diffusers.

For a unique design and a strong coanda effect.



IRYS COANDA 360. 360° air diffusion.



IRYS COANDA 180. 180° air diffusion.

Coanda effect measurements taken in our Panasonic development center.

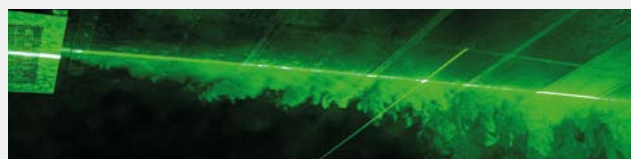

## AC SELECT.

Smart and user-friendly the new air conditioning selection program: <https://acselect.panasonic.eu/>



## Technical features

Fan coil cassette AC fan	P-FQ20		P-FQ30		P-FQ40		P-FQ50		P-FQ60		P-FQ70			
	S2/S3/S4 <sup>1)</sup>		S2/S3/S4 <sup>1)</sup>		S2/S3/S4 <sup>1)</sup>		S2/S3/S4 <sup>1)</sup>		S2/S3/S4 <sup>1)</sup>		S2/S3/S4 <sup>1)</sup>			
<b>2-pipes</b>														
Total cooling capacity <sup>2)</sup>	kW	1,54/1,76/2,36		1,87/2,87/3,99		2,78/3,49/4,69		3,35/4,43/6,07		3,69/5,46/7,18		4,04/6,48/8,61		
Sensible capacity <sup>2)</sup>	kW	1,29/1,48/1,98		1,41/2,17/3,04		2,08/2,67/3,62		2,52/3,35/4,47		2,67/4,06/5,42		2,97/4,85/6,34		
Water flow <sup>2)</sup>	l/h	265/303/404		323/493/683		478/597/801		576/762/1042		636/937/1233		695/1111/1476		
Water pressure drop <sup>2)</sup>	kPa	4,0/5,0/10,0		3,0/7,0/14,0		6,0/10,0/18,0		7,0/12,0/22,0		3,0/6,0/11,0		5,0/12,0/20,0		
Heating capacity <sup>3)</sup>	kW	1,92/2,17/2,74		1,94/3,15/3,68		3,16/3,92/5,28		3,80/5,08/6,84		3,85/6,26/8,51		4,38/7,95/10,28		
Water flow <sup>3)</sup>	l/h	331/374/472		334/543/634		544/675/909		655/875/1178		663/1078/1466		754/1369/1771		
Water pressure drop <sup>3)</sup>	kPa	6,0/7,0/10,0		3,0/9,0/11,0		7,0/10,0/17,0		8,0/13,0/22,0		3,0/8,0/14,0		6,0/17,0/26,0		
<b>4-pipes</b>														
Total cooling capacity <sup>2)</sup>	kW	1,29/1,48/1,97		1,99/2,68/3,37		2,55/3,21/4,00		—		2,97/4,96/6,63		3,17/6,01/7,55		
Sensible capacity <sup>2)</sup>	kW	1,18/1,38/1,84		1,49/2,07/2,65		2,03/2,58/3,30		—		2,23/3,77/5,06		2,38/4,68/5,95		
Water flow <sup>2)</sup>	l/h	232/258/359		342/465/576		437/563/683		—		511/851/1137		543/1030/1294		
Water pressure drop <sup>2)</sup>	kPa	6,0/8,0/13,0		4,0/7,0/11,0		6,0/10,0/15,0		—		5,0/14,0/24,0		6,0/20,0/30,0		
Heating capacity <sup>4)</sup>	kW	1,09/1,27/1,67		3,10/4,40/5,46		4,32/5,00/5,80		—		5,28/7,79/10,04		6,43/10,07/12,77		
Water flow <sup>4)</sup>	l/h	94/109/144		267/379/470		372/431/500		—		455/671/865		554/867/1100		
Water pressure drop <sup>4)</sup>	kPa	15,0/17,0/28,0		7,0/13,0/20,0		13,0/17,0/23,0		—		4,0/7,0/11,0		5,0/11,0/16,0		
<b>Sound levels</b>														
Sound power	2-pipes	dB(A)	38/42/49		35/47/53		42/48/57		35/40/49		38/46/54		40/52/59	
	4-pipes	dB(A)	37/41/49		35/47/53		42/48/57		—		38/46/54		40/52/59	
Sound pressure <sup>5)</sup>	2-pipes	dB(A)	27/31/40		26/35/44		33/39/48		26/31/40		29/37/45		31/43/50	
	4-pipes	dB(A)	27/31/40		26/35/44		33/39/48		—		29/37/45		31/43/50	
NR <sup>5)</sup>	2-pipes		23/27/35		20/30/39		28/34/43		21/26/35		22/32/40		25/38/50	
	4-pipes		23/27/35		20/30/39		28/34/43		—		22/32/40		25/38/45	
<b>Ventilation</b>														
Number of fans			1		1		1		1		1		1	
Air flow	m <sup>3</sup> /h	360/450/659		320/504/734		486/626/900		529/720/979		500/824/1159		601/1080/1447		
Filter		G1		G1		G1		G1		G1		G1		
<b>Electrical data</b>														
Power supply	Voltage	V	230		230		230		230		230		230	
	Phase		Single phase		Single phase		Single phase		Single phase		Single phase		Single phase	
	Frequency	Hz	50/60		50/60		50/60		50/60		50/60		50/60	
Consumption	2-pipes	W	25/35/58		17/34/58		38/58/99		28/41/66		34/61/88		44/92/125	
	4-pipes	W	25/35/58		17/34/58		38/58/99		—		34/61/88		44/92/125	
Electric heater	W	1500		2500		2500		2x1500		2x1500		2x1500		
<b>Water connections</b>														
Connection type			Female gas threaded		Female gas threaded		Female gas threaded		Female gas threaded		Female gas threaded		Female gas threaded	
2 or 4-pipes	Cooling	Inch	¾		¾		¾		1		1		1	
4-pipes	Heating	Inch	½		½		½		—		¾		¾	
<b>Dimension</b>														
With IRYS COANDA 180	LxWxH	mm	595x595x353		595x595x353		595x595x353		849x849x366		849x849x366		849x849x366	
With IRYS COANDA 360	LxWxH	mm	595x595x341		595x595x341		595x595x341		849x849x358		849x849x358		849x849x358	
With plastic diffuser	LxWxH	mm	720x720x334		720x720x334		720x720x334		960x960x339		960x960x339		960x960x339	
<b>Weight</b>														
Weight	kg	14,8		16,5		16,5		37,1		37,1		39,6		

Energy efficiency class<sup>6)</sup>

Fan coil cassette AC fan								
2-pipes	FCEER	A to E	D	C	D	C	C	C
	FCCOP	A to E	E	D	D	C	C	D
4-pipes	FCEER	A to E	E	C	D	—	C	D
	FCCOP	A to E	E	C	D	—	C	C

1) Fan speeds. 2) According to Eurovent standard. Air: 27 °C DB/19 °C WB, chilled water: 7 °C/12 °C. 3) According to Eurovent standard. Air: 20 °C, hot water: 45 °C/40 °C. 4) According to Eurovent standard. Air: 20 °C, hot water: 65 °C/55 °C. 5) Informative data, considering an hypothetical sound attenuation of the room and installation of 9 dB(A). 6) According to Eurovent. \*\*\* Drain pump and G1 air filter are included as standard.

## Accessories and options

2 way or 3 way valves
Auxiliary drain pan
Electric heaters (from 1500 W to 3000 W)
Electromechanical sensor for automatic change over
Fresh air intake
G4 filter
IRC: infrared remote control for Plogic
Modbus communication board for Plogic

## Accessories and options

Plastic or metallic (IRYS COANDA) diffusers (mandatory)
SRC - mini BMS controller
Plogic controller (other electromechanical or electronic control systems also available)
TControl EASY 3S and TControl POD glass controllers (other electromechanical or electronic control systems also available)
WRC: wall-mounted remote control for Plogic



ErP compliant following COMMISSION REGULATION (EU) 2016/2281.



# Fan coil cassette EC fan

Fan coil cassette units with cooling and heating.

Cooling capacity: 1,3 to 9,6 kW.

Heating capacity: 1,1 to 14,0 kW.



Optional controller.  
WRC remote control.



Optional controller.  
SRC - mini BMS  
controller.



Optional controller.  
Electronic controller  
TControl POD glass.



Optional controller.  
Electronic controller  
TControl EASY 3S.



Optional controller.  
Wired remote controller  
with touch control.  
PAW-FC-907EC



Optional controller.  
Wired remote controller.  
PAW-FC-903EC

+ SEE PAGE 542 FOR MORE DETAILS ABOUT FAN COIL CONTROLLERS

## Operating limits

Entering water temperature (without glycol).

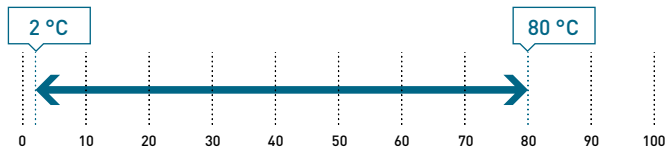

Indoor air temperature.

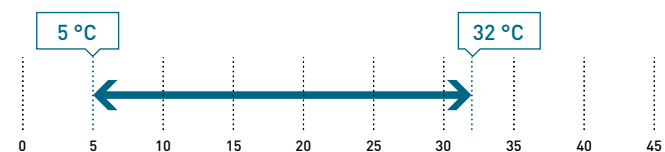

## The range at a glance

- Versions: 2-pipes, 2-pipes + electric heater and 4-pipes
- 6 sizes
- Low energy consumption EC fan: 100% controllable via a 0-10 V signal or 3 operating speeds
- Air flow from 360 to 1598 m<sup>3</sup>/h
- Integrated condensate drain pump
- G1 cleanable air filter

## Advantages

- Excellent performances: FCEER and FCCOP up to "A"
- Aesthetic and IRYS COANDA design diffusers with strong coanda effect
- Silent units
- Easy installation and maintenance: all connections on the same side. Electrical box and valves outside of the unit
- Low built-in-height
- Perfect integration into standard 600 x 600 ceiling tiles\*
- Valves and drain pump factory mounted

\* From 20 to 40 with IRYS COANDA diffusers.

## IRYS COANDA diffusers.

For a unique design and a strong coanda effect.



IRYS COANDA 360.  
360° air diffusion.

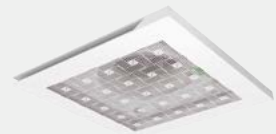

IRYS COANDA 180.  
180° air diffusion.

Coanda effect measurements taken in our Panasonic development center.

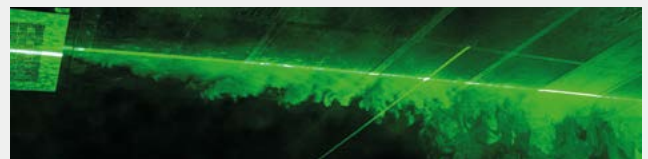

## AC SELECT.

Smart and user-friendly the new air conditioning selection program: <https://acselect.panasonic.eu/>



## Technical features

Fan coil cassette EC fan		P-FQ20		P-FQ30		P-FQ40		P-FQ50		P-FQ60		P-FQ70		
		2V/6V/10V <sup>1)</sup>		2V/6V/10V <sup>1)</sup>		2V/6V/10V <sup>1)</sup>		2V/6V/10V <sup>1)</sup>		2V/6V/10V <sup>1)</sup>		2V/6V/10V <sup>1)</sup>		
<b>2-pipes</b>														
Total cooling capacity <sup>2)</sup>	kW	1,55/1,77/2,38	1,88/2,88/4,00	2,79/3,51/4,71	3,36/4,44/6,09	3,71/5,48/7,20	4,05/6,51/9,61							
Sensible capacity <sup>2)</sup>	kW	1,30/1,49/2,00	1,42/2,18/3,05	2,09/2,69/3,64	2,53/3,36/4,49	2,69/4,08/5,44	2,98/4,88/7,21							
Water flow <sup>2)</sup>	l/h	267/306/409	325/497/688	481/604/808	579/765/1050	640/944/1243	700/1119/1649							
Water pressure drop <sup>2)</sup>	kPa	4,0/5,0/10,0	3,0/7,0/14,0	6,0/10,0/18,0	7,0/12,0/22,0	3,0/6,0/11,0	5,0/12,0/25,0							
Heating capacity <sup>3)</sup>	kW	1,92/2,17/2,74	1,94/3,15/3,68	3,16/3,92/5,28	3,80/5,08/6,84	3,85/6,26/8,51	4,38/7,95/11,03							
Water flow <sup>3)</sup>	l/h	331/374/472	334/543/634	544/675/909	655/875/1178	663/1078/1466	754/1369/1900							
Water pressure drop <sup>3)</sup>	kPa	6,0/7,0/10,0	3,0/9,0/11,0	7,0/10,0/17,0	8,0/13,0/22,0	3,0/8,0/14,0	6,0/17,0/29,0							
<b>4-pipes</b>														
Total cooling capacity <sup>2)</sup>	kW	1,30/1,49/1,99	2,00/2,69/3,38	2,56/3,23/4,02	—	2,99/4,98/6,65	3,18/6,04/7,97							
Sensible capacity <sup>2)</sup>	kW	1,19/1,39/1,86	1,50/2,08/2,66	2,04/2,60/3,32	—	2,25/3,79/5,08	2,39/4,71/6,34							
Water flow <sup>2)</sup>	l/h	234/262/344	344/464/581	442/556/690	—	516/858/1144	549/1041/1366							
Water pressure drop <sup>2)</sup>	kPa	6,0/8,0/13,0	4,0/7,0/11,0	6,0/10,0/15,0	—	5,0/14,0/24,0	6,0/20,0/33,0							
Heating capacity <sup>4)</sup>	kW	1,09/1,27/1,67	3,10/4,40/5,46	4,32/5,00/5,80	—	5,28/7,79/10,00	6,43/10,67/13,99							
Water flow <sup>4)</sup>	l/h	94/109/144	267/379/470	372/431/500	—	455/671/865	554/867/1205							
Water pressure drop <sup>4)</sup>	kPa	13,0/17,0/28,0	7,0/13,0/20,0	13,0/17,0/23,0	—	4,0/7,0/11,0	5,0/11,0/19,0							
<b>Sound levels</b>														
Sound power	2-pipes	dB(A)	36/40/49	35/44/53	42/48/57	35/40/49	38/46/54	40/52/61						
	4-pipes	dB(A)	36/40/49	35/44/53	42/48/57	—	38/46/54	40/52/61						
Sound pressure <sup>5)</sup>	2-pipes	dB(A)	27/31/40	26/35/44	33/39/48	26/31/40	29/37/45	31/43/50						
	4-pipes	dB(A)	27/31/40	26/35/44	33/39/48	—	29/37/45	31/43/50						
NR <sup>5)</sup>	2-pipes		23/27/35	20/30/39	28/34/43	21/26/35	22/32/40	25/38/45						
	4-pipes		23/27/35	20/30/39	28/34/43	—	22/32/40	25/38/45						
<b>Ventilation</b>														
Number of fans			1	1	1	1	1	1	1	1	1	1	1	
Air flow	m <sup>3</sup> /h		360/450/659	320/504/734	486/626/900	529/720/979	500/824/1159	601/1080/1598						
Filter			G1	G1	G1	G1	G1	G1						
<b>Electrical data</b>														
Power supply	Voltage	V	230	230	230	230	230	230	230	230	230	230	230	
	Phase		Single phase	Single phase	Single phase	Single phase	Single phase	Single phase	Single phase	Single phase	Single phase	Single phase	Single phase	
	Frequency	Hz	50/60	50/60	50/60	50/60	50/60	50/60	50/60	50/60	50/60	50/60	50/60	
Consumption	2-pipes	W	9/13/29	7/14/33	13/23/57	7/12/25	9/23/45	11/40/115						
	4-pipes	W	9/13/29	7/14/32	13/22/57	—	9/23/45	11/40/115						
Electric heater	W		1500	2500	2500	2x1500	2x1500	2x1500						
<b>Water connections</b>														
Connection type			Female gas threaded	Female gas threaded	Female gas threaded	Female gas threaded	Female gas threaded	Female gas threaded	Female gas threaded	Female gas threaded	Female gas threaded	Female gas threaded	Female gas threaded	
2 or 4-pipes	Cooling	Inch	¾	¾	¾	1	1	1						
4-pipes	Heating	Inch	½	½	½	—	¾	¾						
<b>Dimension</b>														
With IRYS COANDA 180	L x W x H	mm	595 x 595 x 353	595 x 595 x 353	595 x 595 x 353	849 x 849 x 366	849 x 849 x 366	849 x 849 x 366						
With IRYS COANDA 360	L x W x H	mm	595 x 595 x 341	595 x 595 x 341	595 x 595 x 341	849 x 849 x 358	849 x 849 x 358	849 x 849 x 358						
With plastic diffuser	L x W x H	mm	720 x 720 x 334	720 x 720 x 334	720 x 720 x 334	960 x 960 x 339	960 x 960 x 339	960 x 960 x 339						
<b>Weight</b>														
Weight	kg		14,8	16,5	16,5	37,1	37,1	39,6						

## Energy efficiency class<sup>6)</sup>

Fan coil cassette EC fan		FCEER	A to E	B	A	B	A	A	A
2-pipes	FCCOP	A to E	B	A	B	B	A	A	A
	FCEER	A to E	B	A	B	—	A	B	B
4-pipes	FCCOP	A to E	C	A	B	—	A	A	A

1) Fan standard factory set speeds (voltage). 2) According to Eurovent standard. Air: 27 °C DB/19 °C WB, chilled water: 7 °C/12 °C. 3) According to Eurovent standard. Air: 20 °C, hot water: 45 °C/40 °C. 4) According to Eurovent standard. Air: 20 °C, hot water: 65 °C/55 °C. 5) Informative data, considering an hypothetical sound attenuation of the room and installation of 9 dB(A). 6) According to Eurovent. \*\*\* Drain pump and G1 air filter are included as standard.

### Accessories and options

2 way or 3 way valves
Auxiliary drain pan
Ecospeed card for EC fans
Electric heaters (from 1500 W to 3000 W)
Electromechanical sensor for automatic change over
Fresh air intake
G4 filter
IRC: infrared remote control for Plogic

### Accessories and options

Modbus communication board for Plogic
Plastic or metallic (IRYS COANDA) diffusers (mandatory)
SRC - mini BMS controller
Plogic controller (other electromechanical or electronic control systems also available)
TControl EASY 3S and TControl POD glass controllers (other electromechanical or electronic control systems also available)
WRC: wall-mounted remote control for Plogic



ErP compliant following COMMISSION REGULATION (EU) 2016/2281.



# Fan coil wall AC fan

Fan coil wall-mounted units with cooling and heating.

Cooling capacity: 1,0 to 4,0 kW.

Heating capacity: 1,4 to 4,5 kW.



Optional controller.  
WRC remote control.



Optional controller.  
SRC - mini BMS  
controller.



Optional controller.  
Electronic controller  
TControl POD glass.



Optional controller.  
Electronic controller  
TControl EASY 3S.



Optional controller.  
Wired remote  
controller with  
touch control.  
PAW-FC-907AC



Optional controller.  
Wired remote  
controller.  
PAW-FC-903AC



Optional controller.  
Advanced wired  
remote controller.  
PAW-FC-RC1

+ SEE PAGE 542 FOR MORE DETAILS ABOUT FAN COIL CONTROLLERS

## Operating limits

Entering water temperature (without glycol).

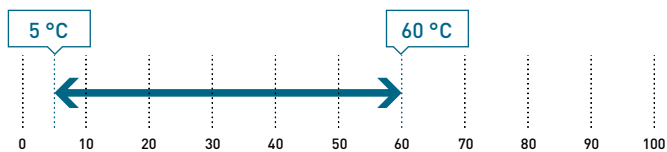

Indoor air temperature.

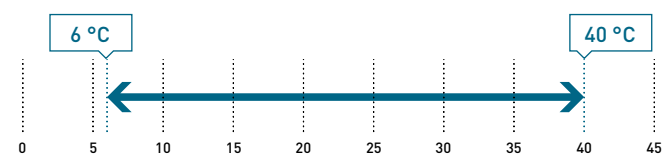

## AC SELECT.

Smart and user-friendly the new air conditioning selection program: <https://acselect.panasonic.eu/>



## The range at a glance

- Versions (2-pipes): infrared without valve (IR SV), infrared with valve (IR AV) and terminal block without valve (TB SV)
- 4 sizes
- 3-speed AC fan
- Air flow from 280 to 850 m<sup>3</sup>/h
- G1 cleanable air filter

## Advantages

- Reversible
- Aesthetic design
- Light for easy installation
- Silent units
- Very easy servicing through a removable front panel
- Cleanable synthetic-type air filter

## Accessories and options

2 way or 3 way valves

Modbus communication board for Plogic

SRC - mini BMS controller

Plogic controller (other electromechanical or electronic control systems also available)

TControl EASY 3S and TControl POD glass controllers (other electromechanical or electronic control systems also available)

WRC: wall-mounted remote control for Plogic

## Technical features

Fan coil wall AC fan		P-FW07(IR) S2/S3/S4 <sup>1)</sup>	P-FW09(IR) S2/S3/S4 <sup>1)</sup>	P-FW18(IR) S2/S3/S4 <sup>1)</sup>	P-FW22(IR) S2/S3/S4 <sup>1)</sup>
<b>2-pipes, without valve, without/with IR infrared control</b>					
Total cooling capacity <sup>2)</sup>	kW	1,00/1,34/1,69	1,58/1,79/2,50	2,78/3,05/3,60	2,93/3,29/4,00
Sensible capacity <sup>2)</sup>	kW	0,72/0,97/1,20	1,21/1,37/1,87	2,12/2,39/2,74	2,28/2,62/3,11
Water flow <sup>2)</sup>	l/h	172/231/291	270/308/431	479/525/620	505/565/687
Water pressure drop <sup>2)</sup>	kPa	18,6/24,9/31,4	18,5/21,4/31,0	34,6/40,0/52,3	37,2/42,8/54,9
Heating capacity <sup>3)</sup>	W	1,42/1,62/1,72	1,68/1,92/2,80	2,99/3,30/4,10	3,18/3,63/4,50
Water flow <sup>3)</sup>	l/h	245/279/296	289/331/482	515/568/706	548/625/775
Water pressure drop <sup>3)</sup>	kPa	17,6/23,4/26,5	21,4/23,5/28,6	39,9/46,3/64,7	41,7/55,0/85,8
<b>Sound levels</b>					
Sound power	dB(A)	45/49/51	40/43/52	47/50/54	50/55/60
Sound pressure <sup>4)</sup>	dB(A)	30/33/35	32/36/40	39/41/43	39/43/48
NR <sup>4)</sup>	dB(A)	32/36/38	34/39/44	40/43/46	43/46/50
<b>Ventilation</b>					
Number of fans		1	1	1	1
Air flow	m <sup>3</sup> /h	282/321/360	367/413/551	532/592/680	617/709/850
Filter		G1	G1	G1	G1
<b>Electrical data</b>					
Power supply	Voltage	V	230	230	230
	Phase		Single phase	Single phase	Single phase
	Frequency	Hz	50	50	50
Consumption	Cooling	W	39/42/62	30/33/40	44/48/53
	Heating	W	39/42/62	27/30/50	42/45/60
<b>Water connections</b>					
Connection type		Female gas threaded	Female gas threaded	Female gas threaded	Female gas threaded
Connections	Inch	½	½	½	½
<b>Dimension and weight</b>					
Dimension	L x W x H	mm	845 x 180 x 275	845 x 180 x 275	940 x 200 x 298
Weight		kg	11	11	13
Fan coil wall AC fan		P-FW09IR-3W S2/S3/S4 <sup>1)</sup>		P-FW22IR-3W S2/S3/S4 <sup>1)</sup>	
<b>2-pipes, with valve, with IR infrared control</b>					
Total cooling capacity <sup>2)</sup>	kW	1,11/1,25/1,40		2,32/2,68/3,10	
Sensible capacity <sup>2)</sup>	kW	0,91/1,08/1,25		1,68/1,98/2,28	
Water flow <sup>2)</sup>	l/h	191/215/241		400/460/532	
Water pressure drop <sup>2)</sup>	kPa	14,9/16,8/18,8		42,4/50,8/61,5	
Heating capacity <sup>3)</sup>	W	1,29/1,61/2,00		2,51/2,75/3,30	
Water flow <sup>3)</sup>	l/h	222/277/344		432/474/568	
Water pressure drop <sup>3)</sup>	kPa	16,1/21,3/28,2		45,8/48,6/54,1	
<b>Sound levels</b>					
Sound power	dB(A)	44/50/54		53/57/60	
Sound pressure <sup>4)</sup>	dB(A)	32/36/40		39/43/48	
NR <sup>4)</sup>	dB(A)	27/31/37		34/37/41	
<b>Ventilation</b>					
Number of fans		1		1	
Air flow	m <sup>3</sup> /h	150/250/400		290/400/600	
Filter		G1		G1	
<b>Electrical data</b>					
Power supply	Voltage	V	230		230
	Phase		Single phase		Single phase
	Frequency	Hz	50		50
Consumption	Cooling	W	35/38/43		50/58/69
	Heating	W	30/33/43		50/58/69
<b>Water connections</b>					
Connection type		Female gas threaded		Female gas threaded	
Connections	Inch	½		½	
<b>Dimension and weight</b>					
Dimension	L x W x H	mm	845 x 180 x 275		940 x 200 x 298
Weight		kg	11		13

1) Fan standard factory set speeds. 2) According to Eurovent standard. Air: 27 °C DB/19 °C WB, chilled water: 7 °C/12 °C. 3) According to Eurovent standard. Air: 20 °C, hot water: 45 °C/40 °C. 4) Informative data, considering an hypothetical sound attenuation of the room and installation of 9 dB(A).



ErP compliant following COMMISSION REGULATION (EU) 2016/2281.



# Fan coil duct EC fan

Fan coil medium static pressure ductable units with cooling and heating.

Cooling capacity: 0,7 to 6,7 kW.

Heating capacity: 0,5 to 7,1 kW.



Optional controller. WRC remote control.



Optional controller. SRC - mini BMS controller.



Optional controller. Electronic controller TControl POD glass.



Optional controller. Electronic controller TControl EASY 3S.



Optional controller. Wired remote controller with touch control. PAW-FC-907EC



Optional controller. Wired remote controller. PAW-FC-903EC

+ SEE PAGE 542 FOR MORE DETAILS ABOUT FAN COIL CONTROLLERS

## Operating limits

Entering water temperature (without glycol).

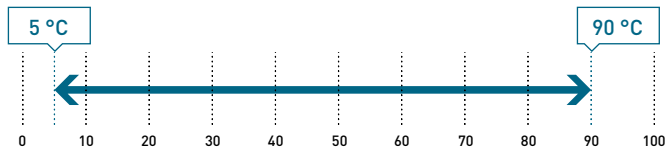

Indoor air temperature.

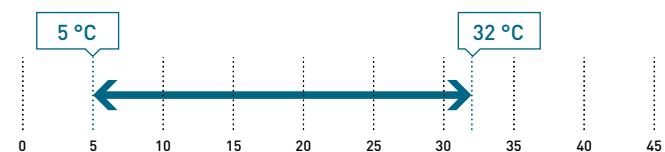

## The range at a glance

- Versions: 2-pipes, 2-pipes + electric heater and 4-pipes
- 6 sizes
- Low energy consumption EC fan: 100% controllable via a 0-10 V signal or 3 operating speeds
- Air flow from 82 to 1293 m<sup>3</sup>/h
- Static pressure up to 120 Pa
- Many air inlet/outlet configurations
- Left or right water / electric connections

## Advantages

- Excellent performances: FCEER and FCCOP up to "A"
- Silent units: internal acoustic and thermal insulation
- Highly customisable: many aeraulic configurations and selection of hydraulic, and electric service side
- Ease of installation: very low height (223 mm)
- Easy maintenance: direct access to the internal components
- Mono-bloc drain pan
- 100% factory tested

## Air inlet/outlet configurations.

### I configurations.

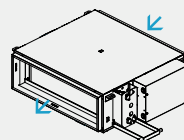

Rectangular return and discharge (standard).

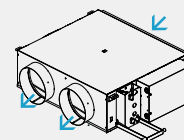

Rectangular return and circular discharge.

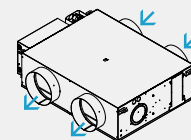

Circular return and discharge.

### J configuration.

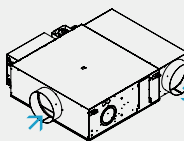

Circular return and discharge.

### L configuration.

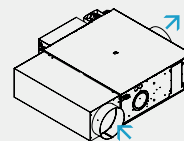

Circular return and discharge.

### U configuration.

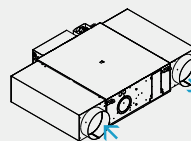

Circular return and discharge.

## AC SELECT.

Smart and user-friendly the new air conditioning selection program: <https://acselect.panasonic.eu/>



Technical features

Fan coil duct EC fan			P-FD10	P-FD15	P-FD20	P-FD25	P-FD30	P-FD40
			2V/7,35V/10V <sup>1)</sup>	3,8V/6,00V/8,2V <sup>1)</sup>	4,8V/7,15V/8,9V <sup>1)</sup>	3,1V/3,9V/4,85V <sup>1)</sup>	2V/6V/10V <sup>1)</sup>	2,1V/5,5V/10V <sup>1)</sup>
<b>2-pipes</b>								
Total cooling capacity <sup>2)</sup>	kW		0,7/1,2/1,5	1,39/1,88/2,06	1,83/2,42/2,74	2,42/2,77/3,2	1,90/3,66/4,80	2,4/4,94/6,66
Sensible capacity <sup>2)</sup>	kW		0,67/1,08/1,36	1,16/1,6/1,96	1,46/1,92/2,21	1,96/2,24/2,63	1,42/2,82/3,68	1,8/4,1/6,13
Water flow <sup>2)</sup>	l/h		121/207/258	239/324/355	315/416/472	416/477/551	327/630/827	413/851/1148
Water pressure drop <sup>2)</sup>	kPa		2,38/5,29/7,52	6,1/9,3/10,5	9,5/15,5/19,5	19,7/25,3/33,1	15,2/44/70,3	8,2/29,7/51,7
Heating capacity <sup>3)</sup>	kW		0,51/1,28/1,82	1,45/2,07/2,55	2,07/2,47/2,59	2,58/3,02/3,39	1,90/3,83/5,01	2,4/5,1/7,06
Water flow <sup>3)</sup>	l/h		87,8/220/313	250/357/439	357/425/446	444/520/584	327/660/863	410/878/1216
Water pressure drop <sup>3)</sup>	kPa		1,54/5,85/10,3	6,5/10,6/14,3	11,9/16,1/17,6	22,3/30/37,3	10,3/37,6/62,8	8,2/31,4/57,6
<b>4-pipes</b>								
Total cooling capacity <sup>2)</sup>	kW		0,71/1,35/1,58	1,34/1,78/2,18	1,78/2,38/2,74	2,19/2,69/2,94	1,72/3,54/4,57	2,22/4,76/6,37
Sensible capacity <sup>2)</sup>	kW		0,67/1,20/1,42	1,11/1,52/1,73	1,42/1,9/2,22	1,73/2,16/2,39	1,24/2,61/3,39	1,77/4,02/5,63
Water flow <sup>2)</sup>	l/h		122/233/272	231/307/376	306/410/472	377/463/506	296/610/787	382/821/1097
Water pressure drop <sup>2)</sup>	kPa		2,43/6,36/8,18	5,8/8,5/11,4	9,1/15,1/19,5	13,3/19,4/22,9	8,6/32,4/52,7	7,2/27,8/57,1
Heating capacity <sup>4)</sup>	kW		0,65/1,66/2,16	1,79/2,54/2,88	2,6/3,02/3,12	3,16/3,59/4,03	1,73/3,27/4,10	2,64/5,05/6,61
Water flow <sup>4)</sup>	l/h		56/143/186	154/219/248	224/260/269	308/344/385	149/282/353	227/435/569
Water pressure drop <sup>4)</sup>	kPa		1,36/4,88/7,24	5,9/11,1/13,9	12,1/18/19,7	11,5/14,9/18,9	3,27/12,3/19,6	3,5/37,3/120
<b>Sound levels</b>								
Sound power return - radiated <sup>5)</sup>	2-pipes	dB(A)	31/52/55	44/55/60	46/57/61	50/55/61	40/58/64	42/58/68
	4-pipes	dB(A)	29/52/55	44/55/60	50/57/61	50/55/61	40/58/64	43/58/68
Sound power - discharge <sup>5)</sup>	2-pipes	dB(A)	31/51/55	41/52/58	50/57/61	50/56/61	36/56/64	39/57/70
	4-pipes	dB(A)	34/51/57	41/52/58	50/57/61	50/56/61	36/56/64	38/54/70
Sound pressure <sup>6)</sup>	2-pipes	dB(A)	<20/35/38	26/37/42	31/40/44	33/39/44	20/39/47	23/39/52
	4-pipes	dB(A)	<20/35/38	26/37/42	31/40/44	33/39/44	20/39/47	24/39/52
NR <sup>6)</sup>	2-pipes		9/30/33	21/32/37	26/35/39	28/34/39	15/34/42	18/34/47
	4-pipes		6/30/33	21/32/37	26/35/39	28/34/39	15/34/42	19/34/47
<b>Ventilation</b>								
Number of fans			1	1	1	1	1	1
Air flow <sup>5)</sup>	2-pipes	m <sup>3</sup> /h	82/247/357	255/383/491	360/501/599	448/541/642	300/738/1068	347/848/1293
	4-pipes	m <sup>3</sup> /h	85/292/384	228/351/452	331/467/560	413/503/602	255/654/943	319/802/1228
External static pressure	2-pipes	Pa	3,3/30/62,6	22/50/82	26/50/72	34/50/70	8/50/105	8/50/116
	4-pipes	Pa	2,5/30/51,8	21/50/83	25/50/72	34/50/72	8/50/104	8/50/117
<b>Electrical data</b>								
Power supply	Voltage	V	230	230	230	230	230	230
	Phase		Single phase	Single phase	Single phase	Single phase	Single phase	Single phase
	Frequency	Hz	50/60	50/60	50/60	50/60	50/60	50/60
Consumption	2-pipes	W	7/19/35	11/29/56	19/50/70	25/41/64	9/65/163	10/62/197
	4-pipes	W	7/20/36	11/28/53	20/47/76	26/41/69	8/60/147	10/60/188
Electric heater	W		500	600/1000	600/1000	1000/2000	1000/2000	1250/2500
<b>Water connections</b>								
Connection type			Female gas threaded	Female gas threaded	Female gas threaded	Female gas threaded	Female gas threaded	Female gas threaded
2 or 4-pipes	Cooling	Inch	1/2	1/2	1/2	1/2	1/2	3/4
4-pipes	Heating	Inch	1/2	1/2	1/2	1/2	1/2	1/2
<b>Dimension and weight</b>								
Dimension without drain pan	L x W x H	mm	633 x 631 x 223	733 x 631 x 223	833 x 631 x 223	933 x 631 x 223	933 x 631 x 223	1233 x 653 x 223
Weight		kg	14	16	18	20	22	29

Energy efficiency class<sup>7)</sup>

Fan coil duct EC fan								
2-pipes	FCEER	A to E	C	B	B	B	B	A
	FCCOP	A to E	C	A	B	A	B	A
4-pipes	FCEER	A to E	C	B	B	B	B	A
	FCCOP	A to E	C	A	A	A	B	A

1) Fan standard factory set speeds (voltage). 2) According to Eurovent standard. Air: 27 °C DB/19 °C WB, chilled water: 7 °C/12 °C. 3) According to Eurovent standard. Air: 20 °C, hot water: 45 °C/40 °C. 4) According to Eurovent standard. Air: 20 °C, hot water: 65 °C/55 °C. 5) According to Eurovent 6/10 (air flow test method) and 8/12 (sound test method). 6) Informative data, considering an hypothetical sound attenuation of the room and installation of 21 dB(A). 7) According to Eurovent.  
 \* Data with I configuration with rectangular return and discharge and G2 (P-FD10/15/20/25/30) or G3 (P-FD40) filter.

Accessories and options	
2 way or 3 way valves	
Circuit breakers	
Condensate drain pump	
Ecospeed card for EC fans	
Electric heaters (from 500 W to 2500 W)	
Fresh air intake	
Fuse holder	
G2/G3 filter	

Accessories and options	
Many air inlet/outlet configurations	
Electromechanical sensor for automatic change over	
Modbus communication board for Plogic	
Other speeds configuration (standard factory set speeds in technical features table)	
SRC - mini BMS controller	
Suspension kit	

Accessories and options	
Plogic controller (other electromechanical or electronic control systems also available)	
TControl EASY 3S and TControl POD glass controllers (other electromechanical or electronic control systems also available)	
WRC: wall-mounted remote control for Plogic	



ErP compliant following COMMISSION REGULATION (EU) 2016/2281.



# Fan coil high static duct AC fan

Fan coil high static pressure ductable units with cooling and heating.

Cooling capacity: 4,1 to 24,8 kW.

Heating capacity: 4,1 to 25,0 kW.



Optional controller.  
WRC remote control.



Optional controller.  
SRC - mini BMS  
controller.



Optional controller.  
Electronic controller  
TControl POD glass.



Optional controller.  
Electronic controller  
TControl EASY 3S.



Optional controller.  
Wired remote  
controller with  
touch control.  
PAW-FC-907AC



Optional controller.  
Wired remote  
controller.  
PAW-FC-903AC



Optional controller.  
Advanced wired  
remote controller.  
PAW-FC-RC1

+ SEE PAGE 542 FOR MORE DETAILS ABOUT FAN COIL CONTROLLERS

## Operating limits

Entering water temperature (without glycol).

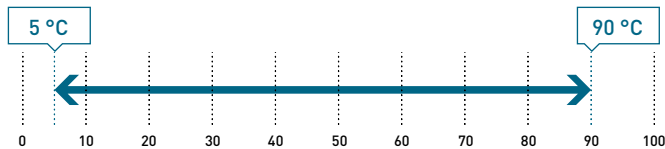

Indoor air temperature.

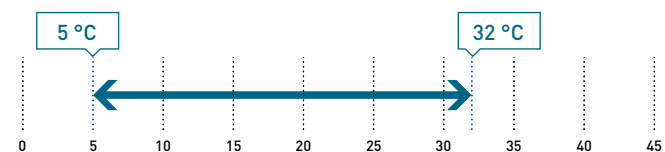

## AC SELECT.

Smart and user-friendly the new air conditioning selection program: <https://acselect.panasonic.eu/>



## The range at a glance

- Versions: 2-pipes, 2-pipes + electric heater and 4-pipes
- 6 sizes
- 5 or 4-speed AC fan - standard factory set speeds.  
07/15/18/21: S1,S3,S5 (5-speed fan motor) and 24/27: S1,S2,S3 (4-speed fan motor)
- Air flow from 586 to 3451 m<sup>3</sup>/h
- High available static pressure up to 220 Pa
- Left or right water / electric connections

## Advantages

- Very low acoustic level at low speed (double skin insulation available as an accessory)
- Selection of hydraulic and electric service side
- Ease of installation and maintenance
- 100% factory tested

## Accessories and options

2 way or 3 way valves
Auxiliary drain pan
Circuit breakers
Condensate drain pump
Double skin acoustic insulation
Electric heaters (from 1000 W to 3000 W)
Fresh air intake
Fuse holder
G3/G4 filter
Inlet and outlet plenums for circular ducts (07 only)
Electromechanical sensor for automatic change over
Modbus communication board for Plologic
Other speeds configuration (standard factory set speeds in technical features table)
SRC - mini BMS controller
Suspension kit
Plologic controller (other electromechanical or electronic control systems also available)
TControl EASY 3S and TControl POD glass controllers (other electromechanical or electronic control systems also available)
WRC: wall-mounted remote control for Plologic

## Technical features

Fan coil high static duct AC fan		P-FH7		P-FH15		P-FH18		P-FH21		P-FH24		P-FH27		
		S1/S3/S5 <sup>1)</sup>		S1/S3/S5 <sup>1)</sup>		S1/S3/S5 <sup>1)</sup>		S1/S3/S5 <sup>1)</sup>		S1/S2/S3 <sup>1)</sup>		S1/S2/S3 <sup>1)</sup>		
<b>2-pipes</b>														
Total cooling capacity <sup>2)</sup>	kW	4,43/5,32/5,59		6,9/11,48/13,33		6,32/11,48/13,87		7,07/13,7/17		14,78/16,67/19,03		16,4/18,9/21,9		
Sensible capacity <sup>2)</sup>	kW	3,14/3,97/4,25		5,04/9,19/11,23		4,94/9,48/11,89		4,93/9,94/12,5		10,68/12,27/14,23		11,4/13,3/15,5		
Water flow <sup>2)</sup>	l/h	765/919/965		1191/1982/2302		1091/1982/2395		1221/2365/2935		2552/2878/3286		2832/3263/3781		
Water pressure drop <sup>2)</sup>	kPa	27,4/39,2/43,5		7,9/19,8/26,1		6,8/19,6/27,6		8,5/28,7/43,5		14,7/18,3/23,3		13,6/17,6/23		
Heating capacity <sup>3)</sup>	kW	4,06/5,53/6,7		6,6/12/15,48		7,2/14/18,01		6,95/13,9/17,8		15/17,4/20,9		15,4/17,9/21,5		
Water flow <sup>3)</sup>	l/h	701/955/1157		1140/2072/2673		1243/2417/3110		1200/2400/3073		2590/3004/3609		2659/3091/3712		
Water pressure drop <sup>3)</sup>	kPa	24,1/43,5/63,2		5/17,9/26,3		6,1/16,1/24,3		12,4/21,8/34,1		11,4/21,9/28,1		10,7/21/27,3		
<b>4-pipes</b>														
Total cooling capacity <sup>2)</sup>	kW	4,05/4,84/5,08		6,38/10,08/11,33		6,77/11,18/12,83		7,75/14,38/17,43		13,68/15,27/17,13		14,78/16,77/19,13		
Sensible capacity <sup>2)</sup>	kW	2,86/3,57/3,8		4,76/8,42/10,13		5,01/9,13/11,13		5,45/10,58/13,23		10,18/11,67/13,33		10,68/12,27/14,23		
Water flow <sup>2)</sup>	l/h	699/836/877		1102/1740/1956		1169/1930/2215		1338/2483/3009		2362/2637/2958		2552/2896/3303		
Water pressure drop <sup>2)</sup>	kPa	31/43/47,2		5,8/13,3/16,9		6,9/17,1/22,6		11,1/34,9/50,9		15,3/18,8/23,3		13,5/17/21,5		
Heating capacity <sup>4)</sup>	kW	5,5/7/7,7		9,6/17/21		9,7/17,06/21		9,7/17,1/21		10,9/12,9/15,2		18,5/25/29,6		
Water flow <sup>4)</sup>	l/h	475/604/665		829/1468/1813		837/1473/1813		837/1476/1813		941/1114/1312		1597/2158/2555		
Water pressure drop <sup>4)</sup>	kPa	9/13,3/15		32,7/92,1/134		20,2/56,1/80		20,2/56,1/80		30,8/39/49,5		38,8/67,2/82		
<b>Sound levels</b>														
Sound power return - radiated <sup>5)</sup>	2-pipes	dB(A)	57/60/63		52/66/72		54/66/74		52/66/72		65/69/73		65/69/73	
	4-pipes	dB(A)	54/60/63		52/66/72		52/66/72		52/66/72		65/69/73		65/69/73	
Sound power - discharge <sup>5)</sup>	2-pipes	dB(A)	53/59/62		52/64/71		52/64/71		52/74/71		64/67/72		64/67/72	
	4-pipes	dB(A)	53/59/62		52/64/71		52/64/71		52/64/71		64/67/72		64/67/72	
Sound pressure <sup>6)</sup>	2-pipes	dB(A)	33/39/42		31/45/51		31/45/51		31/45/51		44/48/52		44/48/52	
	4-pipes	dB(A)	33/39/42		31/45/51		31/45/51		31/45/51		44/48/52		44/48/52	
NR <sup>6)</sup>	2-pipes		27/34/37		27/40/47		27/40/47		27/40/47		40/44/48		40/44/48	
	4-pipes		27/34/37		27/40/47		27/40/47		27/40/47		40/44/48		40/44/48	
<b>Ventilation</b>														
Number of fans		1		1		1		1		1		1		
Filter		G3		G3		G3		G3		G3		G3		
Air flow <sup>5)</sup>	2-pipes	m <sup>3</sup> /h	703/977/1125		960/2112/2830		960/2112/2830		960/2112/2830		2040/2413/2925		2040/2413/2925	
	4-pipes	m <sup>3</sup> /h	586/824/974		960/2112/2830		960/2112/2830		960/2112/2830		2040/2413/2925		2040/2413/2925	
External static pressure	2-pipes	Pa	30/50/70		15/50/90		15/50/90		15/50/90		35/50/75		35/50/75	
	4-pipes	Pa	25/50/70		15/50/90		15/50/90		15/50/90		35/50/75		35/50/75	
<b>Electrical data</b>														
Power supply	Voltage	V	230		230		230		230		230		230	
	Phase		Single phase		Single phase		Single phase		Single phase		Single phase		Single phase	
	Frequency	Hz	50/60		50/60		50/60		50/60		50/60		50/60	
Consumption	W	132/182/222		180/421/675		180/421/675		180/421/675		420/530/673		420/530/673		
Electric heater	W	2000		3000		3000		3000		3000		3000		
<b>Water connections</b>														
Connection type		Female gas threaded	Male gas threaded		Male gas threaded		Male gas threaded		Male gas threaded		Male gas threaded		Male gas threaded	
2-pipes	Inch	½	1		1 ¼		1 ¼		1 ¼		1 ¼		1 ¼	
	Cooling	Inch	½		1		1		1		1 ¼		1 ¼	
4-pipes	Inch	½	¾		¾		¾		¾		¾		¾	
	Heating	Inch	¾		¾		¾		¾		¾		¾	
<b>Dimension and weight</b>														
Dimension	L x W x H	mm	1200 x 698 x 250		1380 x 798 x 375		1380 x 798 x 375		1380 x 798 x 375		1500 x 798 x 450		1500 x 798 x 450	
Weight		kg	42		63		65		67		76		80	

Energy efficiency class<sup>7)</sup>

Fan coil high static duct AC fan		FCEER	A to E	D	D	D	D	D	D
2-pipes	FCEER	A to E	D	D	D	D	D	D	D
	FCCOP	A to E	C	C	C	C	C	C	D
4-pipes	FCEER	A to E	D	D	D	D	D	D	D
	FCCOP	A to E	C	C	C	C	C	D	D

1) Fan standard factory set speeds. 2) According to Eurovent standard. Air: 27 °C DB/19 °C WB, chilled water: 7 °C/12 °C. 3) According to Eurovent standard. Air: 20 °C, hot water: 45 °C/40 °C. 4) According to Eurovent standard. Air: 20 °C, hot water: 65 °C/55 °C. 5) According to Eurovent 6/10 (air flow test method) and 8/12 (sound test method). 6) Informative data, considering a hypothetical sound attenuation of the room and installation of 21 dB(A). 7) According to Eurovent.

\* Data with I configuration with rectangular return and discharge.



ErP compliant following COMMISSION REGULATION (EU) 2016/2281.



# Fan coil high static duct EC fan

Fan coil high static pressure ductable units with cooling and heating.

Cooling capacity: 3,2 to 21,9 kW.

Heating capacity: 2,5 to 24,1 kW.



Optional controller.  
WRC remote control.



Optional controller.  
SRC - mini BMS  
controller.



Optional controller.  
Electronic controller  
TControl POD glass.



Optional controller.  
Electronic controller  
TControl EASY 3S.



Optional controller.  
Wired remote controller  
with touch control.  
PAW-FC-907EC



Optional controller.  
Wired remote controller.  
PAW-FC-903EC

+ SEE PAGE 542 FOR MORE DETAILS ABOUT FAN COIL CONTROLLERS

## Operating limits

Entering water temperature (without glycol).

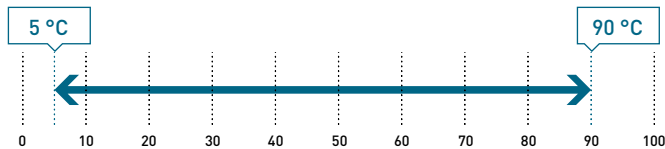

Indoor air temperature.

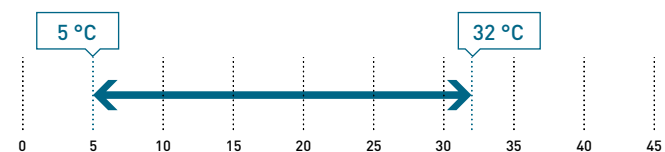

## AC SELECT.

Smart and user-friendly the new air conditioning selection program: <https://acselect.panasonic.eu/>

## The range at a glance

- Versions: 2-pipes, 2-pipes + electric heater and 4-pipes
- 6 sizes
- Low energy consumption EC fan: 100% controllable via a 0-10 V signal or 3 operating speeds
- Air flow from 320 to 3568 m<sup>3</sup>/h
- High available static pressure up to 220 Pa
- Left or right water / electric connections

## Advantages

- Excellent performances: FCEER and FCCOP up to "A"
- Very low acoustic level at low speed (double skin insulation available as an accessory)
- Selection of hydraulic and electric service side
- Ease of installation and maintenance
- 100% factory tested

## Accessories and options

2 way or 3 way valves
Auxiliary drain pan
Circuit breakers
Condensate drain pump
Double skin acoustic insulation
Electric heaters (from 1000 W to 3000 W)
Fresh air intake
Fuse holder
G3/G4 filter
Inlet and outlet plenums for circular ducts (07 only)
Electromechanical sensor for automatic change over
Modbus communication board for Plologic
Other speeds configuration (standard factory set speeds in technical features table)
SRC - mini BMS controller
Suspension kit
Plologic controller (other electromechanical or electronic control systems also available)
TControl EASY 3S and TControl POD glass controllers (other electromechanical or electronic control systems also available)
WRC: wall-mounted remote control for Plologic



Technical features

Fan coil high static duct EC fan		P-FH7		P-FH15		P-FH18		P-FH21		P-FH24		P-FH27		
		3,33V/5,87V/8,67V <sup>1)</sup>		2V/4V/5V <sup>1)</sup>		2V/4V/5V <sup>1)</sup>		2V/4V/5V <sup>1)</sup>		2V/5V/7V <sup>1)</sup>		2V/5V/7V <sup>1)</sup>		
<b>2-pipes</b>														
Total cooling capacity <sup>2)</sup>	kW	3,26/4,90/5,88		7,93/10,1/11,1		8,98/11,7/12,8		9,79/12,7/13,9		10,6/16,1/17,6		11,7/18,1/19,9		
Sensible capacity <sup>2)</sup>	kW	2,05/3,59/4,56		6,08/8,05/8,9		6,71/9,02/10		7,14/9,55/10,60		7,84/12,4/13,7		8,43/13,6/15,1		
Water flow <sup>2)</sup>	l/h	562/844/1013		1369/1744/1917		1551/2020/2210		1690/2193/2400		1826/2780/3039		2022/3125/3436		
Water pressure drop <sup>2)</sup>	kPa	15/33,5/48,1		13,2/19,8/23		9,1/14,2/16,7		10,2/15,4/17,9		8,04/18,4/21,4		7,58/19,1/22,5		
Heating capacity <sup>3)</sup>	kW	2,47/5,61/9,26		8,66/11,7/13		9,48/13,1/14,6		9,99/14,1/15,8		10,9/17,6/19,5		11,6/19,1/21,4		
Water flow <sup>3)</sup>	l/h	425/966/1595		1495/2020/2245		1637/2262/2521		1725/2435/2728		1872/3039/3367		1993/3298/3695		
Water pressure drop <sup>3)</sup>	kPa	7,2/33,7/89,0		12,2/20,6/24,9		8,2/14,2/17,3		8,3/15/18,5		10,9/21,5/25,8		6,38/17,1/20,9		
<b>4-pipes</b>														
Total cooling capacity <sup>2)</sup>	kW	3,22/4,74/5,54		6,57/8,21/8,91		7,4/9,26/10		8,92/11,3/12,4		9,51/14/15,2		10,2/15,3/16,8		
Sensible capacity <sup>2)</sup>	kW	2,12/3,48/4,25		5,2/6,76/7,43		5,7/7,48/8,24		6,66/8,75/9,64		7,13/11/12,1		7,52/11,8/13,1		
Water flow <sup>2)</sup>	l/h	555/817/954		1134/1418/1538		1278/1599/1727		1540/1951/2141		1642/2417/2624		1761/2642/2901		
Water pressure drop <sup>2)</sup>	kPa	20,6/41,4/55,3		6,6/10,2/12		8/11,2/12,7		11,2/16,7/19,4		9,4/18,7/21,9		6,6/13,9/16,4		
Heating capacity <sup>4)</sup>	kW	3,93/6,81/9,05		5,85/7,45/8,13		10/12,9/14,2		10/11,9/14,2		8/11,9/13		7,71/11,7/12,9		
Water flow <sup>4)</sup>	l/h	338/586/779		505/643/702		863/1114/1226		863/1114/1226		691/1027/1122		666/1010/1114		
Water pressure drop <sup>4)</sup>	kPa	5,6/12,5/19,5		14,1/21,4/25		23/35/40,9		22,8/34,8/40,8		13,5/27,5/32,1		5,2/11,3/13,4		
<b>Sound levels</b>														
Sound power return - radiated <sup>5)</sup>	2-pipes	dB(A)	54/60/63		56/65/67		56/65/67		56/65/67		58/69/73		58/69/73	
	4-pipes	dB(A)	54/60/63		56/65/67		56/65/67		56/65/67		58/69/73		58/69/73	
Sound power - discharge <sup>5)</sup>	2-pipes	dB(A)	53/59/62		56/64/65		56/64/65		56/64/65		58/67/72		58/67/72	
	4-pipes	dB(A)	53/59/62		56/64/65		56/64/65		56/64/65		58/67/72		58/67/72	
Sound pressure <sup>6)</sup>	2-pipes	dB(A)	33/39/42		35/44/46		35/44/46		35/44/46		37/48/52		37/48/52	
	4-pipes	dB(A)	33/39/42		35/44/46		35/44/46		35/44/46		37/48/52		37/48/52	
NR <sup>6)</sup>	2-pipes		27/34/37		31/40/42		31/40/42		31/40/42		33/44/48		33/44/48	
	4-pipes		27/34/37		31/40/42		31/40/42		31/40/42		33/44/48		33/44/48	
<b>Ventilation</b>														
Number of fans		1		1		1		1		1		1		
Filter		G3		G3		G3		G3		G3		G3		
Air flow <sup>5)</sup>	2-pipes	m <sup>3</sup> /h	347/849/1293		1360/2044/2335		1360/2044/2335		1360/2044/2335		1519/2700/3098		1519/2700/3098	
	4-pipes	m <sup>3</sup> /h	320/803/1229		1360/2044/2335		1360/2044/2335		1360/2044/2335		1519/2700/3098		1519/2700/3098	
External static pressure	2-pipes	Pa	8/50/116		22/50/65		22/50/65		22/50/65		16/50/66		16/50/66	
	4-pipes	Pa	8/50/117		22/50/65		22/50/65		22/50/65		16/50/66		16/50/66	
<b>Electrical data</b>														
Power supply	Voltage	V	230		230		230		230		230		230	
	Phase		Single phase		Single phase		Single phase		Single phase		Single phase		Single phase	
	Frequency	Hz	50/60		50/60		50/60		50/60		50/60		50/60	
Consumption	2-pipes	W	10/62/197		61/172/246		61/172/246		61/172/246		57/237/364		57/237/364	
	4-pipes	W	10/60/189		61/172/246		61/172/246		61/172/246		57/237/364		57/237/364	
Electric heater	W	2000		3000		3000		3000		3000		3000		
<b>Water connections</b>														
Connection type			Female gas threaded		Male gas threaded		Male gas threaded		Male gas threaded		Male gas threaded		Male gas threaded	
2-pipes	Inch	½		1		1 ¼		1 ¼		1 ¼		1 ¼		
	Cooling	Inch	½		1		1		1		1 ¼		1 ¼	
4-pipes	Heating	Inch	½		¾		¾		¾		¾		¾	
<b>Dimension and weight</b>														
Dimension	L x W x H	mm	1200 x 698 x 250		1380 x 798 x 375		1380 x 798 x 375		1380 x 798 x 375		1500 x 798 x 450		1500 x 798 x 450	
Weight		kg	42		63		65		67		76		80	

Energy efficiency class<sup>7)</sup>

Fan coil high static duct EC fan		FCEER		A to E		—		A		A		B		A	
2-pipes	FCCOP	A to E		—		A		A		A		A		A	
	FCEER	A to E		—		B		B		A		A		A	
4-pipes	FCCOP	A to E		—		B		A		A		B		B	
	FCEER	A to E		—		B		A		A		B		B	

1) Fan standard factory set speeds (voltage). 2) According to Eurovent standard. Air: 27 °C DB/19 °C WB, chilled water: 7 °C/12 °C. 3) According to Eurovent standard. Air: 20 °C, hot water: 45 °C/40 °C. 4) According to Eurovent standard. Air: 20 °C, hot water: 65 °C/55 °C. 5) According to Eurovent 6/10 (air flow test method) and 8/12 (sound test method). 6) Informative data, considering an hypothetical sound attenuation of the room and installation of 9 dB(A). 7) According to Eurovent.  
 \* Data with I configuration with rectangular return and discharge.

## Fan coil controllers

Panasonic has a wide, technological range of controllers and control systems suitable for installation within a wide variety of locations such as office, hotel, and residential applications. These controllers are compatible with AC and EC fans and allow users to take advantage of the improved performance and efficiency and thus energy savings. Most of our controllers have an intuitive user interface to easily setup the desired configurations.



### 1 Individual controllers

Thanks to these controllers it is possible to control one fan coil unit individually. All our controllers fall into this category. Depending on the model, they can have different features: possibility to set the desired temperature, compatibility with AC and EC fans, LCD display, wall or unit mounting.

### 2 Group controllers

These controllers allow the control of more than one fan coil unit per controller but maintaining the same fan and temperature settings (a slight temperature variation is possible within the same zone). Plologic is the Panasonic group controller that allows you to control multiple units with a single control.

### 3 Centralized and group controller

Due to the advanced technical capability, it is possible to control different climatic zones with different settings and ambient conditions. The combination of Plologic + BMS and SRC are the perfect example for this type of control.

## Plologic (zone controller) with remote control

### 1| Plologic. Different individual control possibilities.

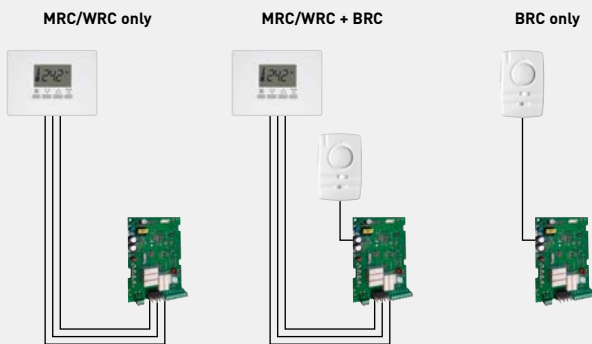

### 2| Plologic. Group control (without BMS).

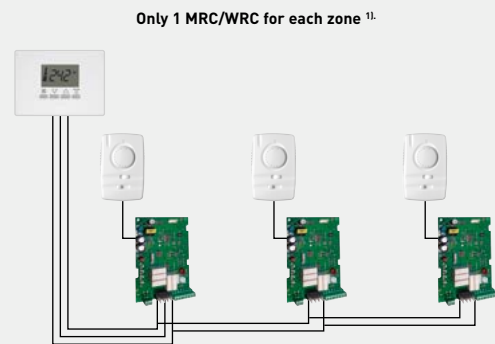

1) Up to 15 Plologic/fan coil units. Fan coil units can be of different types, with AC or EC fan motor.

### 3| Centralized and group control with BMS and SRC.

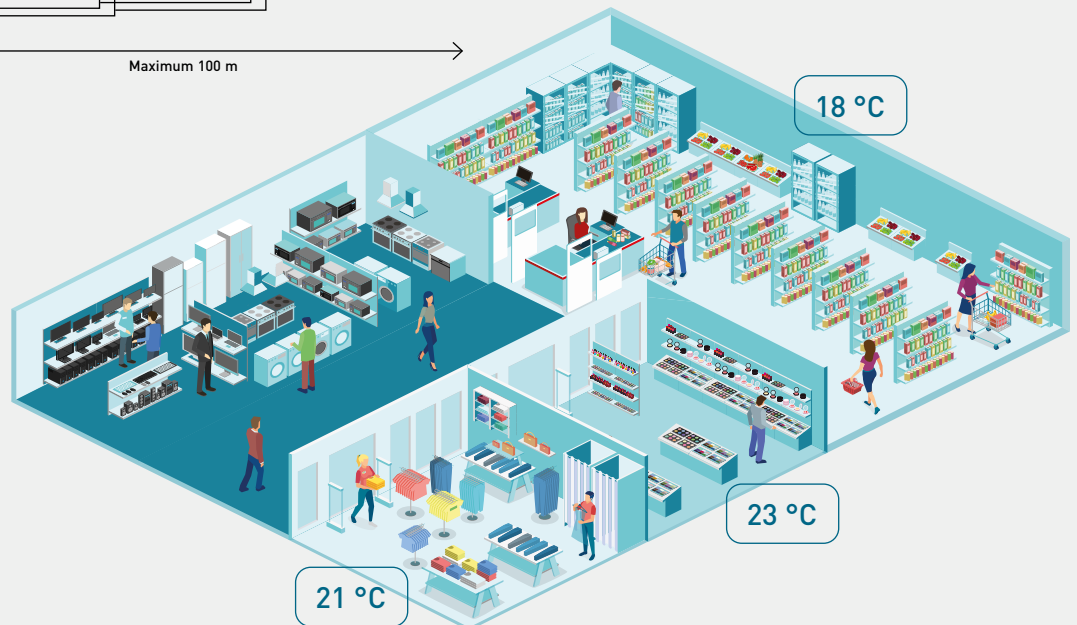
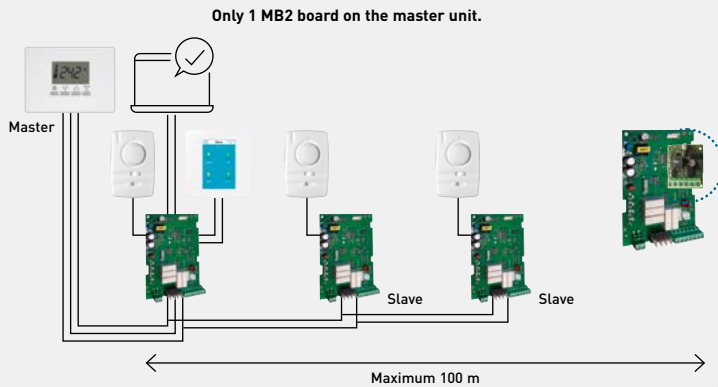

## Electro-mechanical and electronic control systems



	TRM-FA	Plogic
2-pipes (cooling or heating)	✓	✓
2-pipes heat pump	✓	✓
2-pipes cooling + electric heater (≤ 2000 W)	✓	✓
2-pipes heat pump + electric heater (≤ 2000 W)	—	✓
4-pipes	✓	✓
Communication protocol	—	Modbus (with MB2 card)
SRC mini BMS compatibility	—	✓
<b>Functions</b>		
Changeover	Manual	Manual or Auto <sup>1)</sup>
Fan speed selection	Manual	Manual or Auto
Fan operation	Cyclic <sup>2)</sup>	Continuous <sup>3)</sup> or cyclic <sup>2)</sup>
Master/slave	—	✓ Up to 15 slave units
Time programming	—	—
<b>Fan compatibility</b>		
AC	✓	✓
EC with ecospeed card	✓	—
EC 0-10 V	—	✓
<b>Valve compatibility</b>		
ON / OFF 230 V	✓	✓
<b>Controller power supply</b>		
230 V	—	✓
<b>Mounting type</b>		
Wall-mounted or mounted on the unit	Wall	Unit

1) Changeover Auto with water pipe sensor. 2) Cyclic: fan stops when the set point is reached. 3) Continuous: fan continues running after the set point is reached.

## SRC - mini BMS controller

### Smart controller. Mini building management system.

- Supervise Panasonic fan coil units, chillers/heat pumps, air handling units and water source heat pumps <sup>1)</sup>
- Can be used as a mini BMS or a remote control
- Manage up to 15 zones and 31 units
- Communicate via Modbus protocol
- Time programming function
- A modern and refined design
- 3,5" color touch screen
- Wall mounting

1) Consult documentation for more details.

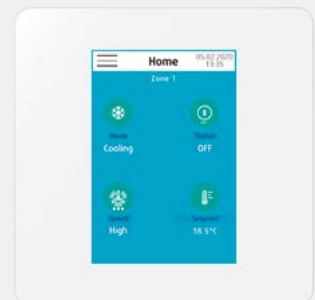



TControl EASY 3S	TControl POD glass	PAW-FC-RC1	PAW-FC-903EC PAW-FC-907EC	PAW-FC-903AC PAW-FC-907AC
✓	✓	✓	✓	✓
✓	✓	—	—	—
—	✓	—	—	—
—	—	—	—	—
✓	✓	✓	✓	—
—	Modbus	Modbus	Modbus	—
—	✓	✓	✓	—
Manual or Auto <sup>1)</sup>	Manual or Auto <sup>1)</sup> or centralized	Manual or Auto	Manual	Manual
Manual or Auto	Manual or Auto	Manual or Auto	Manual or Auto	Manual or Auto
Continuous <sup>3)</sup> or cyclic <sup>2)</sup>	Continuous <sup>3)</sup> or cyclic <sup>2)</sup>	—	Continuous <sup>3)</sup> or cyclic <sup>2)</sup>	Continuous <sup>3)</sup> or cyclic <sup>2)</sup>
—	—	—	—	—
—	✓	—	—	—
✓	✓	✓	—	✓
✓	—	✓	—	—
—	✓	—	✓	—
✓	✓	✓	✓	✓
✓	✓	✓	✓	✓
Wall (surface or embedded)	Wall (surface or embedded)	Wall (embedded)	Wall (embedded)	Wall (embedded)

## Remote controls

### Plagic.

Wall mounting (surface) or mounted on the unit.



WRC / MRC <sup>1)</sup>



BRC



IRC <sup>1)</sup>

<sup>1)</sup> Integrated temperature sensor.

Compatibilities	Fan coil comfort	Fan coil cassette	Fan coil wall	Fan coil duct	Fan coil high static duct
TRM-FA	✓	✓	✓ <sup>1)</sup>	✓	✓
Plagic	✓	✓	✓ <sup>1)</sup>	✓	✓
TControl POD glass	✓	✓	✓ <sup>1)</sup>	✓	✓
TControl EASY 3S	✓	✓	✓ <sup>1)</sup>	✓	✓
PAW-FC-RC1	✓	✓	✓ <sup>1)</sup>	✓	✓
PAW-FC-903EC PAW-FC-907EC	✓	✓	—	✓	✓
PAW-FC-903AC PAW-FC-907AC	✓	✓	✓ <sup>1)</sup>	—	✓

<sup>1)</sup> Louvres must be manually operated with these controllers.

Note: Electrical heaters maximum power may vary according to the controller without a relay.

# Water source heat pumps

One building, different needs!

Water source heat pumps are ideal for best in class hotels, offices or shopping centers. This solution offers improved comfort by having several different indoor climates inside a building, while maintaining the energy through an internal closed water loop.



## What is a water loop system with water source heat pumps?

**The water loop system enables distributed cooling and heating production at different temperatures with a single water circuit.**

The recovery of condensation heat units in cooling can be used for units in heating and vice-versa, thus providing a balanced and highly efficient system. These indoor units are called water source heat pumps which are equipped with a compressor and 2 heat exchangers to allow energy transfer between the water loop and air within the space.



## Environmentally friendly and economic

\* Model shown: ECOi-LOOP-N EVO.

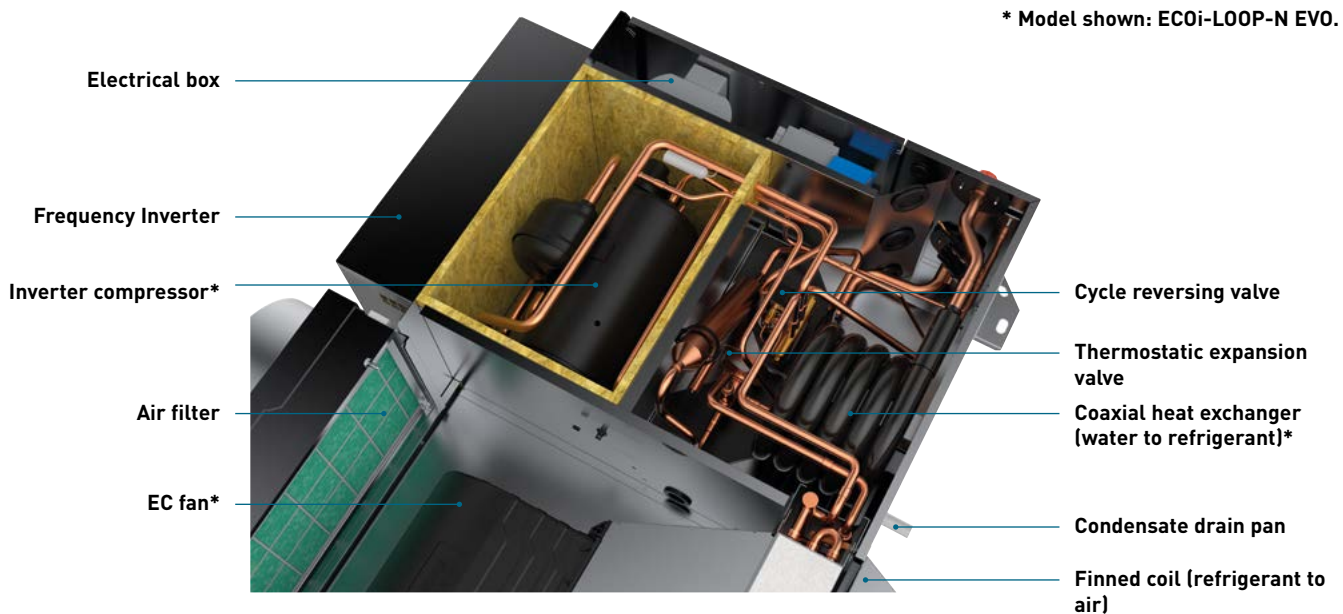











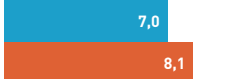

## Key features for ECOi-LOOP.

- High efficiency
- Heating and cooling of rooms at the same time. All units are connected to the same water loop
- Decentralised cool/heat production (closed water circuit)
- Water heater or cooling tower do not need to be operated as long as cooling and heating loads are roughly balanced. Temperature in the water loop will be kept between 16 and 32 °C
- Reduced refrigerant charge (no refrigerant pipes to an outdoor unit required)
- Low risk of leakage (hermetically sealed systems)
- Water source heat pumps can be easily added or removed without changing the system layout
- Each unit is autonomous and has its own controller allowing also its own safety



# Quick selection guide - Water source heat pumps

Page	Size	Cooling and heating capacity (kW)	NR sound levels (at MS)	Nominal air flow <sup>1)</sup> (m <sup>3</sup> /h)	Pressure (Pa)	Fan	Dimension LxWxH (mm)	
P. 550		15		26	435	0-140	EC	900 x 530 x 250 <sup>2)</sup>
		20		30	465	0-140	EC	900 x 530 x 250 <sup>2)</sup>
		30		34	525	0-140	EC	900 x 530 x 250 <sup>2)</sup>
P. 552		70		52	1727	0-495	EC	1142 x 762 x 516 <sup>2)</sup>
		85		50	2165	0-495	EC	1142 x 762 x 516 <sup>2)</sup>
		100		56	2826	0-335	EC	1333 x 818 x 580 <sup>2)</sup>
		110		54	3078	0-250	EC	1333 x 818 x 580 <sup>2)</sup>
		120		55	3309	0-350	EC	1333 x 818 x 580 <sup>2)</sup>
		135		57	3677	0-260	EC	1333 x 818 x 580 <sup>2)</sup>
P. 554			25,8 <sup>3)</sup>	525	0-140	EC	900 x 636 x 250 <sup>2)</sup>	

1) At high speed. 2) Without air inlet/outlet options. 3) At minimum thermal load.

Page	Size	Cooling and heating capacity (kW)	NR sound levels (at MS)	Nominal air flow <sup>1)</sup> (m <sup>3</sup> /h)	Pressure (Pa)	Fan	Dimension LxWxH (mm)			
<b>P. 556</b>		ECOi-LOOP HRW H · R407C		19	5,3 5,8	37	1250	>50	AC	900 x 600 x 439
		ECOi-LOOP HRWE H · R407C		27	7,4 8,3	34	1190	>50	AC	1050 x 600 x 460
		27 HE	7,5 9,3	34	1180	>50	AC	1050 x 660 x 460		
		30	8,7 9,8	35	1490	>100	AC	1050 x 660 x 460		
		30 HE	8,9 10,0	35	1500	>100	AC	1050 x 660 x 460		
		36	10,1 11,0	37	1580	>100	AC	1050 x 660 x 460		
		36 HE	11,1 12,2	37	1580	>100	AC	1250 x 705 x 513		
		42	11,4 14,4	40	2040	>100	AC	1250 x 705 x 513		
		42 HE	12,5 14,5	40	2040	>100	AC	1250 x 705 x 513		
		48	13,0 14,9	43	2750	>100	AC	1250 x 705 x 513		
		60	14,3 16,1	43	2840	>100	AC	1250 x 705 x 513		
		60 HE	16,7 18,8	43	2840	>100	AC	1250 x 705 x 583		
		72	17,1 21,5	39	3570	>100	AC	1250 x 705 x 513		
		72 HE	20,6 22,6	39	3800	>100	AC	1680 x 955 x 770		
		96	21,7 26,6	54	4700	>100	AC	1680 x 955 x 770		
		96 HE	24,5 28,5	54	4700	>100	AC	1680 x 955 x 770		
120	30,0 38,1	53	5600	>200	AC	1680 x 955 x 770				

**ECOi-LOOP FS H · R407C**



**P. 558**

12	2,7 3,2	40	510	0	AC/EC	1138 x 251 x 821 <sup>2)</sup>
----	------------	----	-----	---	-------	--------------------------------

**ECOi-LOOP-N FS H · R513A**



**P. 560**

7	1,7 1,8	34	340	0	AC/EC	1138 x 260 x 821 <sup>2)</sup>
9	2,0 2,6	36	400	0	AC/EC	1138 x 260 x 821 <sup>2)</sup>

1) At high speed. 2) Standard unit with cabinet and feet.



# ECOi-LOOP 15-30 C/H · R410A

Water source heat pumps cooling only and reversible.

Cooling capacity: 1,5 to 2,9 kW.

Heating capacity: 1,9 to 3,7 kW.



Optional controller.  
RCS remote control.



Optional controller.  
SRC - mini BMS controller.



SEE PAGE 562 FOR MORE DETAILS ABOUT WATER SOURCE HEAT PUMPS CONTROL SYSTEMS

## Operating limits

Air inlet temperature.

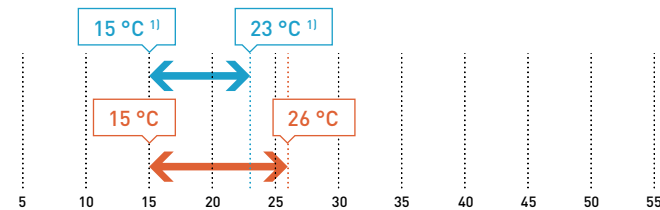

Water inlet temperature.

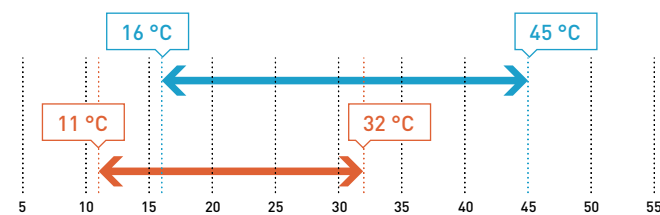

1) From 21 to 32 °C DB. \* Maximum water pressure 10 bars.

## The range at a glance

- 2 versions: C (cooling only) and H (reversible)
- 3 sizes
- Horizontal installation
- Nominal air flow from 435 to 525 m<sup>3</sup>/h
- Many air and water configurations available
- 140 Pa maximum external static pressure
- Operating range: from 15 °C to 32 °C ambient air temperature
- Water inlet temperature from 11 °C to 45 °C

## Advantages

- Very high performances: EER up to 5,05 and COP up to 5,70
- Low energy consumption EC fan
- In-line or perpendicular air flow
- Increased robustness: coaxial heat exchanger
- Easy access to the internal components: large electrical panel and filter accessible from 3 sides
- 100% factory tested

## Equipment

- The refrigerant circuit comprises a rotary type hermetic compressor, a cycle reversal valve (H type only), a water/refrigerant heat exchanger, a liquid receiver, a capillary expansion device, a finned coil, HP and LP pressure switches and 2 Schrader valves (HP and LP)
- The rotary type hermetic compressor, mounted on spring anti-vibration mounts, is integrated in a compartment coated with reinforced acoustic insulation. It is also equipped with internal thermal protection
- The water/refrigerant heat exchanger is of copper/stainless steel coaxial type for an increased efficiency
- The units are equipped with a control system (POL423) utilising Modbus RTU
- The casing is made of galvanised steel sheet
- Condensate drain pan with an anti-corrosion treatment
- The electrical box is located on the hydraulic service side with a wide access panel
- The units are equipped with multi-position brackets for easy installation

## AC SELECT.

Smart and user-friendly the new air conditioning selection program: <https://acselect.panasonic.eu/>





## Technical features

ECOi-LOOP 15-30 C - cooling only		P-LPE015CA	P-LPE020CA	P-LPE030CA
ECOi-LOOP 15-30 H - reversible		P-LPE015HA	P-LPE020HA	P-LPE030HA
Total cooling capacity <sup>1)</sup>	W	1507	2151	2902
Sensible cooling capacity <sup>1)</sup>	W	1371	1733	2355
EER		4,51	5,05	4,25
Heating capacity <sup>2)</sup>	W	1934	2510	3680
COP		5,49	5,70	4,97
<b>Ventilation</b>				
Number of fans			1	
Nominal air flow	m <sup>3</sup> /h	435	465	525
Motor power	W	24	38	53
Air filter	Number / efficiency	1 / Basic or G3M1	1 / Basic or G3M1	1 / Basic or G3M1
<b>Hydraulic circuit</b>				
Water heat exchanger	Number / type	1 / Coaxial	1 / Coaxial	1 / Coaxial
Maximum water pressure	bar	10	10	10
Nominal water flow	l/h	317	444	617
WPD at nominal water flow	kPa	8	12	18
Connections - inlet/outlet (Ø)	Inch	½ Male gas	½ Male gas	½ Male gas
Condensate outlet - external (Ø)	mm	16	16	16
<b>Refrigerant circuit</b>				
Number of refrigerant circuits		1	1	1
Compressor type		Rotary	Rotary	Rotary
Load	g	415	565	565
<b>Electrical data</b>				
Power supply	Voltage	V	230	230
	Phase		Single phase	Single phase
	Frequency	Hz	50 ±10%	50 ±10%
Input power <sup>3)</sup>	Cooling	W	365	471
	Heating	W	389	491
Electric heating coil <sup>4)</sup>	Number / capacity	- / W	1 / 600+600	1 / 800+800
	Input power	W	1200	1600
<b>Sound levels - without acoustic options</b>				
Sound power - radiated	Lo / Med / Hi	dB(A)	41,9 / 43,1 / 44,4	42,7 / 44,5 / 46,5
Sound power - discharge	Lo / Med / Hi	dB(A)	45,6 / 49,1 / 53	49,1 / 53,6 / 58,3
Sound pressure <sup>5)</sup>	Lo / Med / Hi	dB(A)	27,1 / 30 / 33,5	30 / 34,1 / 38,4
NR <sup>5)</sup>	Lo / Med / Hi		22,4 / 25,7 / 29,4	25,8 / 30,1 / 34,4
<b>Sound levels - with air outlet silencer and insulation around the fan</b>				
Sound power - radiated	Lo / Med / Hi	dB(A)	42,3 / 43,2 / 44,5	42,7 / 44,4 / 46,5
Sound power - discharge	Lo / Med / Hi	dB(A)	32,2 / 35,2 / 38,5	34,7 / 38,5 / 42,5
Sound pressure <sup>5)</sup>	Lo / Med / Hi	dB(A)	23,2 / 25 / 27,3	24,8 / 27,7 / 31
NR <sup>5)</sup>	Lo / Med / Hi		18,8 / 20,4 / 22,7	20,1 / 23 / 26,4
<b>Dimension - without air inlet/outlet options</b>				
Length	mm	900	900	900
Width	mm	530	530	530
Height	mm	250	250	250
<b>Weight - without air inlet/outlet options</b>				
Operating weight	kg	48	48	48

1) Nominal cooling capacities based on entering air temperature of 27 °C DB, 19 °C WB with entering water temperature of 30 °C. 2) Nominal heating capacities based on entering air temperature of 20 °C DB, 15 °C WB with entering water temperature of 20 °C. 3) Input power at nominal conditions (compressor + fan at high speed). 4) Electric heating coil is available as an option. 5) Informative data, considering an hypothetical sound attenuation of the room and installation of 21 dB(A). In-line configuration with filter.

### Accessories and options

Air outlet silencer
Basic or G3M1 filter
Circuit breaker
Controller with BACnet MSTP (LON and Modbus TCP/IP available upon request)
Drain outlet
Drain pump
Electric heaters

### Accessories and options

Flow switch control
Insulation around the fan
Many air inlet/outlet and water connection configurations
Pressostatic valve (cooling only)
RCS remote control (for controller with protocol communication)
Room temperature sensor
SRC - mini BMS controller



HIGH  
EER  
5,85

HIGH  
COP  
5,70





# ECOi-LOOP-N 70-135 H · R513A

Water source heat pumps reversible.

Cooling capacity: 7,0 to 13,3 kW.

Heating capacity: 8,1 to 14,6 kW.



Optional controller.  
RCS remote control.



Optional controller.  
SRC - mini BMS controller.

+ SEE PAGE 562 FOR MORE DETAILS ABOUT WATER SOURCE HEAT PUMPS CONTROL SYSTEMS

## Operating limits

Air inlet temperature.

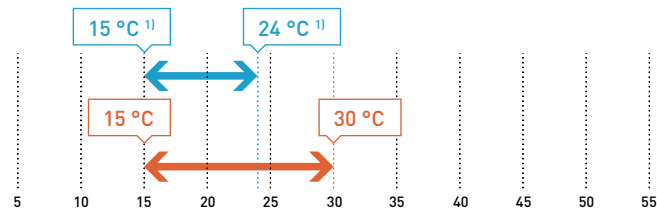

Water inlet temperature.

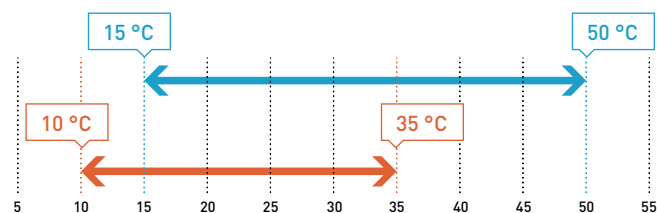

1) From 21 to 33 °C DB. \* Maximum water pressure 10 bars.

## The range at a glance

- 1 version: H (reversible)
- 6 sizes
- Horizontal installation
- Nominal air flow from 1730 to 3680 m<sup>3</sup>/h
- In-line or perpendicular air flow
- Up to 495 Pa according to size
- Operating range: from 15 °C to 32 °C ambient air temperature
- Water inlet temperature from 11 °C to 45 °C

## Advantages

- Very high performances: EER up to 3,95 and COP up to 4,58
- Low energy consumption EC fan
- Increased robustness: coaxial heat exchanger
- Easy access to the internal components: a wide removable panel allows an easy access to the electrical panel and the access to the filter is from the side of the unit, without removing the return duct
- 100% factory tested

## Equipment

- The refrigerant circuit comprises a scroll type hermetic compressor, a cycle reversal valve, a water/refrigerant heat exchanger, a bi-flow thermostatic expansion valve, a finned coil, HP and LP pressure switches and 2 Schrader valves (HP and LP)
- The scroll type hermetic compressor, mounted on spring anti-vibration mounts, is integrated in a compartment coated with reinforced acoustic insulation. It is also equipped with internal thermal protection
- The water/refrigerant heat exchanger is of copper/stainless steel coaxial type for an increased efficiency
- The units are equipped with a control system (POL423) utilising Modbus RTU
- The casing is made of galvanised steel sheet
- Condensate drain pan with an anti-corrosion treatment
- The electrical box is located inside the compressor compartment with a wide access panel

## AC SELECT.

Smart and user-friendly the new air conditioning selection program: <https://acselect.panasonic.eu/>





## Technical features

ECOi-LOOP-N 70-135 H - reversible		P-LPN070HA	P-LPN085HA	P-LPN100HA	P-LPN110HA	P-LPN120HA	P-LPN135HA	
Total cooling capacity <sup>1)</sup>	W	7011	8407	10290	11183	12105	13301	
Sensible cooling capacity <sup>1)</sup>	W	5960	7146	8541	9282	10047	11040	
Total absorbed power <sup>2)</sup>	W	1776	2275	2743	3234	3161	3784	
EER Compressor		4,53	4,21	4,36	4,0	4,46	4,1	
EER according to EN14511		3,95	3,7	3,75	3,46	3,83	3,52	
Total heating capacity <sup>3)</sup>	W	8069	9808	11307	12514	13834	14639	
Total absorbed power <sup>2)</sup>	W	1761	2256	2590	3073	3081	3467	
COP Compressor		5,27	4,96	5,12	4,75	5,25	5,0	
COP according to EN14511		4,58	4,35	4,37	4,07	4,49	4,22	
<b>Ventilation</b>								
EC voltage	V	3,80	5,50	7,80	8,80	7,60	8,60	
Air flow	Min (LS)	m <sup>3</sup> /h	1123	1407	1837	2001	2157	2390
	Med (MS)	m <sup>3</sup> /h	1425	1786	2331	2539	2730	3034
	Max (nominal) (HS)	m <sup>3</sup> /h	1727	2165	2826	3078	3309	3677
Nominal static pressure	Pa	100	100	100	100	100	100	
Fan absorbed power	W	328	393	552	631	617	737	
Fan power	W	684	653	703	738	671	722	
Air filter	Number / efficiency	1 / G2M1	1 / G2M1	1 / G2M1	1 / G2M1	1 / G2M1	1 / G2M1	
<b>Hydraulic circuit</b>								
Water heat exchanger	Number / type	1 / Coaxial	1 / Coaxial	1 / Coaxial	1 / Coaxial	1 / Coaxial	1 / Coaxial	
Maximum water pressure	Bar	10	10	10	10	10	10	
Nominal water flow	Cooling <sup>1)</sup>	l/h	1497	1818	2274	2508	2649	2957
	Heating <sup>3)</sup>	l/h	1882	2256	2514	2738	3143	3463
Cutoff water flow	Cooling	l/h	749	909	1137	1254	1325	1479
	Heating	l/h	941	1128	1257	1369	1572	1732
WPD at nominal water flow	Cooling <sup>1)</sup>	kPa	35,9	49,8	39,6	46,6	30,6	38,3
	Heating <sup>3)</sup>	kPa	52,7	71,3	46,8	53,9	43,4	53
Hydraulic connections - inlet/outlet	Inch	1 Male gas	1 Male gas	1 Male gas	1 Male gas	1 Male gas	1 Male gas	
Condensate outlet (Ø)	mm	19	19	19	19	19	19	
<b>Refrigerant circuit</b>								
Number of refrigerant circuits		1	1	1	1	1	1	
Compressor type		Scroll	Scroll	Scroll	Scroll	Scroll	Scroll	
Load	g	1040	1165	1108	1116	1355	1363	
<b>Electrical data</b>								
Power supply	Voltage	V	400	400	400	400	400	
	Phase		Three phase	Three phase	Three phase	Three phase	Three phase	
	Frequency	Hz	50	50	50	50	50	
Maximum current without heating	A	12,8	13,4	15,6	18,2	17,3	18,1	
Starting current	A	53,5	53,5	53,5	78,5	71,4	78,4	
<b>Sound levels</b>								
Sound power Lw - radiated	Lo / Med / Hi	dB(A)	60,6/65/65,4	59,5/65,3/66,1	61/66,9/69,4	62,1/67,7/10,4	58/62,6/67,4	58,8/63,9/68,8
Sound power Lw - discharge	Lo / Med / Hi	dB(A)	53,8/62,9/71	62,8/69,5/73,6	68,4/72,7/77,1	68,8/72,6/77,2	64,5/69,3/73,5	65,7/71,2/75,6
Sound power Lw	Lo / Med / Hi	dB(A)	63,7/68,1/72,6	65,5/71,4/74,7	69,6/74,1/78,1	70,1/74,3/78,5	66,5/70,9/75,1	67,5/72,7/77
Sound pressure Lp <sup>4)</sup>	Lo / Med / Hi	dB(A)	49/54,3/56,2	49,5/54,3/56,4	55,3/58,8/62,6	54,4/57,6/61,9	52,5/56,8/60,5	52,7/58,5/62,1
NR <sup>4)</sup>	Lo / Med / Hi		45,9/51,5/51,2	45,9/49,9/50,9	52,3/55,5/58,5	52,3/54,4/59,1	50,7/55,2/58,4	50,7/56,9/60,3
<b>Dimension - without air inlet/outlet options</b>								
Length	mm	1142	1142	1333	1333	1333	1333	
Width	mm	762	762	818	818	818	818	
Height	mm	516	516	580	580	580	580	
<b>Weight</b>								
Operating weight	kg	134	134	153	153	160	160	

1) Nominal cooling capacities based on entering air temperature of 27 °C DB, 19 °C WB with entering water temperature of 30 °C. 2) Input power at nominal conditions (compressor + fan at high speed).

3) Nominal heating capacities based on entering air temperature of 20 °C DB, 15 °C WB with entering water temperature of 20 °C. 4) Informative data, considering an hypothetical sound attenuation of the room and installation of 21 dB(A). In-line configuration with filter.

### Accessories and options

G2M1 filter or G3 filter

Circuit breaker

Controller with BACnet MSTP or BACnet IP (LON and Modbus TCP/IP available upon request)

Drain pump

Electric heaters

### Accessories and options

Flow switch control

General default report

Many air configurations

RCS remote control (for controller with protocol communication)

Room temperature sensor

SRC - mini BMS controller





# ECOi-LOOP-N EVO C/H · R513A

Water source heat pumps cooling only and reversible.

Cooling capacity: 1,7 to 2,9 kW.

Heating capacity: 2,0 to 3,8 kW.



Optional controller.  
RCS remote control.



Optional controller.  
SRC - mini BMS controller.

+ SEE PAGE 562 FOR MORE DETAILS ABOUT WATER SOURCE HEAT PUMPS CONTROL SYSTEMS

## Operating limits

Air inlet temperature.

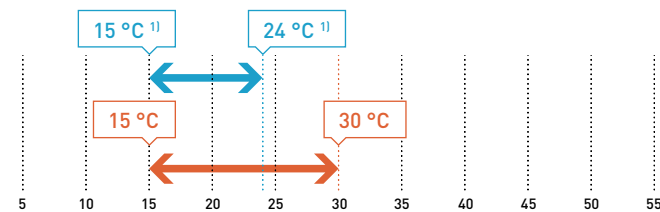

Water inlet temperature.

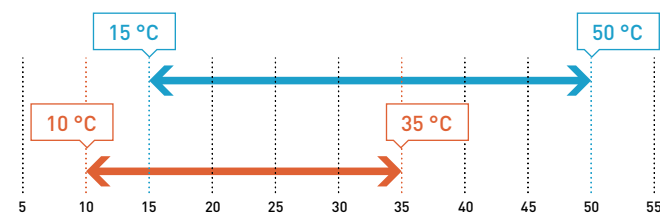

1) From 21 to 33 °C DB. \* Maximum water pressure 10 bars.

## The range at a glance

- Unique size available in C (cooling only) or H (reversible) versions
- Horizontal installation
- Air flow from 290 to 525 m<sup>3</sup>/h
- Inverter compressor technology
- Many air and water configurations available
- 140 Pa maximum external static pressure
- Operating range: from 15 °C to 32 °C ambient air temperature
- Water inlet temperature from 11 °C to 45 °C

## Advantages

- Eco-friendly: R513A refrigerant with very low GWP (631) and low energy consumption EC fan
- Economic: Inverter compressor adapting its speed according to the required capacity
- Extra silent unit: NR<26 at low speed and reinforced insulation
- Very high-performance: EER up to 4,25 and COP up to 4,53
- Low height for an easy integration: only 250 mm
- Highly customisable: many aeraulic configurations and selection of the hydraulic service side
- Increased robustness: coaxial heat exchanger
- Easy access to the internal components: large electrical panel and filter accessible from 3 sides
- 100% factory tested

## Equipment

- The refrigerant circuit comprises an Inverter rotary type hermetic compressor, a cycle reversal valve (for H type), a water/refrigerant heat exchanger, a liquid receiver, a thermostatic expansion valve, a finned coil, HP and LP pressure switches and 2 Schrader valves (HP and LP)
- The Inverter rotary type hermetic compressor, mounted on spring anti-vibration mounts, is integrated in a compartment coated with reinforced acoustic insulation. It is also equipped with internal thermal protection
- The water/refrigerant heat exchanger is of copper/stainless steel coaxial type for an increased efficiency
- The unit is equipped with a complete control system (Modbus RTU or BACnet MSTP protocol communication)
- The casing is made of galvanised steel sheet
- Condensate drain pan with an anti-corrosion treatment
- The electrical box is located on the hydraulic service side with a wide access panel
- The units are equipped with multi-position brackets for easy installation



## Technical features

ECOi-LOOP-N EVO C - cooling only			P-LPVN030CA
ECOi-LOOP-N EVO H - reversible			P-LPVN030HA
Total cooling capacity <sup>1)</sup>	Min - Max <sup>2)</sup>	W	1687 - 2948
Sensible cooling capacity <sup>1)</sup>	Min - Max <sup>2)</sup>	W	1363 - 2337
EER	Min - Max <sup>2)</sup>		4,25 - 3,06
Heating capacity <sup>3)</sup>	Min - Max <sup>2)</sup>	W	2004 - 3769
COP	Min - Max <sup>2)</sup>		4,53 - 3,45
<b>Ventilation</b>			
Number of fans			1
Nominal air flow (at low and high speeds)	Min - Max <sup>2)</sup>	m <sup>3</sup> /h	290 - 525
Motor power (at low and high speeds)	Min - Max <sup>2)</sup>	W	13 - 54
Air filter	Number / efficiency		1 / Basic or G3
<b>Hydraulic circuit</b>			
Water heat exchanger	Number / type		1 / Coaxial
Maximum water pressure		bar	10
Nominal water flow	Cooling Min - Max <sup>2)</sup>	l/h	354 - 662
	Heating Min - Max <sup>2)</sup>	l/h	458 - 789
WPD at nominal water flow <sup>4)</sup>	Cooling Min - Max <sup>2)</sup>	kPa	9 - 19,5
	Heating Min - Max <sup>2)</sup>	kPa	12,3 - 24,6
Connections - inlet/outlet [Ø]		Inch	½ Male gas
Condensate outlet - external [Ø]		mm	16
<b>Refrigerant circuit</b>			
Number of refrigerant circuits			1
Compressor type			Inverter rotary
Load		g	514
<b>Electrical data</b>			
Power supply	Voltage	V	230
	Phase		Single phase
	Frequency	Hz	50 ±10%
Input power <sup>5)</sup>	Cooling Min - Max <sup>2)</sup>	W	397 - 964
	Heating Min - Max <sup>2)</sup>	W	442 - 1093
Electric heating coil <sup>6)</sup>	Number / capacity Min - Max <sup>2)</sup>	- / W	1 / 600 + 600 - 1 / 1000 + 1000
	Input power Min - Max <sup>2)</sup>	W	1200 - 2000
<b>Sound levels - without acoustic options</b>			
Sound power - radiated	Min - Max <sup>2)</sup>	dB(A)	41,9 - 51,5
Sound power - discharge	Min - Max <sup>2)</sup>	dB(A)	47,9 - 62,8
Sound pressure <sup>7)</sup>	Min - Max <sup>2)</sup>	dB(A)	29,3 - 43
NR <sup>7)</sup>	Min - Max <sup>2)</sup>		25,8 - 39,2
<b>Sound levels - with air outlet silencer and insulation around the fan</b>			
Sound power - radiated	Min - Max <sup>2)</sup>	dB(A)	42,3 - 51,6
Sound power - discharge	Min - Max <sup>2)</sup>	dB(A)	33,2 - 44,4
Sound pressure <sup>7)</sup>	Min - Max <sup>2)</sup>	dB(A)	24,5 - 35
NR <sup>7)</sup>	Min - Max <sup>2)</sup>		19,5 - 30,4
<b>Dimension - without air inlet/outlet options</b>			
Length		mm	900
Width		mm	636
Height		mm	250
<b>Weight - without air inlet/outlet options</b>			
Operating weight		kg	51

1) Nominal cooling capacities based on entering air temperature of 27 °C DB, 19 °C WB with entering water temperature of 30 °C. 2) Thermal load. 3) Nominal heating capacities based on entering air temperature of 20 °C DB, 15 °C WB with entering water temperature of 20 °C. 4) Without valve. 5) Input power at nominal conditions (compressor + fan at high speed). 6) Electric heating coil is available as an option. 7) Informative data, considering an hypothetical sound attenuation of the room and installation of 21 dB. In-line configuration with filter.

### Accessories and options

- Air outlet silencer
- Basic or G3M1 filter
- Circuit breaker
- Drain outlet
- Drain pump
- Electric heaters
- Flow switch control

### Accessories and options

- General default report
- Insulation around the fan
- Many air inlet/outlet and water connection configurations
- RCS remote control (for controller with protocol communication)
- Room temperature sensor
- SRC - mini BMS controller



HIGH  
EER  
4,25

HIGH  
COP  
4,53





# ECOi-LOOP HRW H and ECOi-LOOP HRWE H · R407C

Water source heat pumps reversible.

Cooling capacity: 5,3 to 30,0 kW.

Heating capacity: 5,8 to 38,1 kW.



Optional controller.  
RCS remote control.



Optional controller.  
SRC - mini BMS controller.

+ SEE PAGE 562 FOR MORE DETAILS ABOUT WATER SOURCE HEAT PUMPS CONTROL SYSTEMS

## Operating limits

Air inlet temperature.

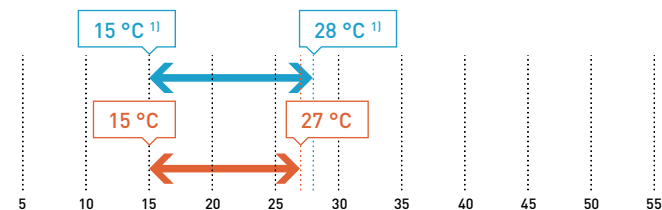

Water inlet temperature.

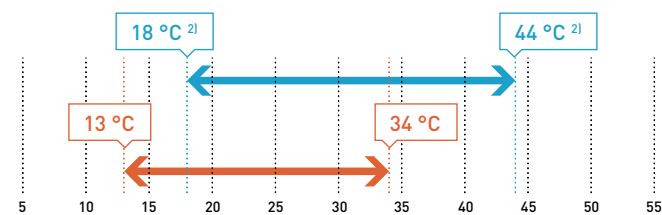

1) From 21 to 38 °C DB. 2) From 20 to 48 °C for 96-120. \* Maximum water pressure 16 bars.

## The range at a glance

- 1 version: H (reversible)
- 10 sizes
- Horizontal installation
- Versions: standard or HE\*\* (very high efficiency)
- Nominal air flow from 1180 to 5600 m<sup>3</sup>/h
- AC fan: 3-speed direct drive fan motor for sizes 19 to 72 and belt drive with variable pitch pulley for sizes 96 and 120
- Operating range: from 15 °C to 38 °C ambient air temperature
- Water inlet temperature from 13°C to 48 °C

## Advantages

- Low sound levels: acoustic insulation between ventilation and compressor compartments
- Very high efficiency versions (HE)\*: EER up to 4,74 and COP up to 4,46
- In-line or perpendicular air flow
- Easy access to components through wide removable panels
- Condensate drain pan with an anti-corrosion treatment and a float-type safety system
- 100% factory tested

## Equipment

- The refrigerant circuit comprises a scroll or rotary type hermetic compressor, a cycle reversal valve (for H type), a water/refrigerant heat exchanger, a liquid receiver, a bi-flow thermostatic expansion valve and a finned coil, HP and LP pressure switches and 2 Schrader valves (HP and LP)
- The rotary or scroll type hermetic compressor, mounted on rubber anti-vibration mounts, is integrated in a compartment coated with reinforced acoustic insulation. It is also equipped with internal thermal protection
- The units are equipped with a control system (POL423) utilising Modbus RTU
- The water/refrigerant heat exchanger is made of brazed stainless steel plates, for improved efficiency
- Condensate drain pan with an anti-corrosion treatment and a float-type safety system
- A G2-M1 air filter is provided within the unit

\* HE versions only available for reversible units.

## AC SELECT.

Smart and user-friendly the new air conditioning selection program: <https://acselect.panasonic.eu/>





Technical features

ECOi-LOOP HRW H - reversible	P-LPHM***HA*** 1)	019	027	—	030	—	036	—	042	—	048	060	—	072	—	096	—	120	
ECOi-LOOP HRWE H - reversible	P-LPHEM***HA*** 1)	—	—	027	—	030	—	036	—	042	—	—	060	—	072	—	096	—	
Total cooling capacity 2)	W	5278	7419	7320	8691	8710	10138	11060	11366	12500	12965	14344	16700	17174	20600	21743	24500	29951	
Sensible cooling capacity 2)	W	4257	5824	5600	6315	6676	7278	9070	8849	9542	10051	10988	13900	13536	17700	17986	19500	24413	
EER		4,20	3,72	4,00	3,77	4,15	3,77	4,31	3,44	4,00	4,03	3,23	4,44	3,26	4,74	3,84	4,61	4,21	
Heating capacity 3)	W	5826	8342	9252	9759	9960	11036	12200	14422	14450	14904	16147	18800	21500	22600	26637	28500	38109	
COP		4,40	3,69	4,21	3,50	4,30	3,38	4,28	3,84	4,36	4,25	3,33	4,20	3,15	4,23	3,54	4,46	4,25	
<b>Ventilation</b>																			
Number of fans		1	1	1	1	1	1	1	1	1	1	1	1	1	1	1	1	1	1
Nominal air flow	m <sup>3</sup> /h	1250	1190	1180	1490	1500	1580	1580	2040	2040	2750	2840	2840	3570	3800	4700	4700	5600	
Motor power	W	450	450	450	950	950	950	950	950	950	1500	1500	1500	1500	736	1100	1100	1500	
Air filter	Number / efficiency	2 / G2-M1	2 / G2-M1	2 / G2-M1	2 / G2-M1	2 / G2-M1	2 / G2-M1	2 / G2-M1	2 / G2-M1	2 / G2-M1	2 / G2-M1	2 / G2-M1	2 / G2-M1	2 / G2-M1	2 / G2-M1	2 / G2-M1	2 / G2-M1	2 / G2-M1	2 / G2-M1
<b>Hydraulic circuit</b>																			
Number of plate heat exchanger		1	1	1	1	1	1	1	1	1	1	1	1	1	1	1	1	1	1
Maximum water pressure	bar	16	16	16	16	16	16	16	16	16	16	16	16	16	16	16	16	16	16
Nominal water flow	l/h	921	1540	1620	1764	1800	2030	2306	2592	2600	2822	3348	3550	3924	4300	4860	4960	6408	
WPD at nominal water flow	kPa	13	17	13	23	20	25	21	33	28	34	40	35	61	50	55	55	80,5	
Connections - inlet/outlet (Ø)	Inch	ISO G ¾ INT	ISO G ¾ INT	ISO G ¾ INT	ISO G ¾ INT	ISO G ¾ INT	ISO G ¾ INT	ISO G ¾ INT	ISO G ¾ INT	ISO G ¾ INT	ISO G ¾ INT	ISO G ¾ INT	ISO G ¾ INT	ISO G 1 ¼	ISO G ¾ INT	ISO G 1 ¼	ISO G 1 ¼	ISO G 1 ¼	ISO G 1 ¼
Condensate outlet - external (Ø)	mm	19	19	19	19	19	19	19	19	19	19	19	19	19	22	22	22	22	
<b>Refrigerant circuit</b>																			
Number of refrigerant circuits		1	1	1	1	1	1	1	1	1	1	1	1	1	1	1	1	1	1
Compressor type		Rotary	Scroll	Scroll	Scroll	Scroll	Scroll	Scroll	Scroll	Scroll	Scroll	Scroll	Scroll	Scroll	Scroll	Scroll	Scroll	Scroll	Scroll
Load	g	1160	1483	2534	1594	1950	1950	3200	3200	2800	3200	3200	3400	2700	3800	5100	5100	5100	
<b>Electrical data</b>																			
Power supply	Voltage	V	230	400	400	400	400	400	400	400	400	400	400	400	400	400	400	400	400
	Phase		Single phase	Three phase	Three phase	Three phase	Three phase	Three phase	Three phase	Three phase	Three phase	Three phase	Three phase	Three phase	Three phase	Three phase	Three phase	Three phase	Three phase
	Frequency	Hz	50 ±10%	50+ Neutral	50+ Neutral	50+ Neutral	50+ Neutral	50+ Neutral	50+ Neutral	50+ Neutral	50+ Neutral	50+ Neutral	50+ Neutral	50+ Neutral	50+ Neutral	50+ Neutral	50+ Neutral	50+ Neutral	50+ Neutral
Input power 4)	Cooling	W	1557	2118	1981	2658	2357	3044	2909	3584	3423	4200	4989	4278	6280	5279	6317	5954	8547
	Heating	W	1611	2332	2382	2983	2475	3460	3203	3920	3479	4300	5150	5098	7347	6188	7895	7115	10224
Electric heating coil	Number / capacity	- / W	2 / 1500 + 750	1 / 3750	1 / 3750	1 / 3750	1 / 3750	1 / 4500	1 / 4500	1 / 5400	1 / 5400	1 / 6500	1 / 7500	1 / 7500	1 / 9000	1 / 9000	1 / 13000	1 / 13000	1 / 16000
<b>Sound levels</b>																			
Sound power - radiated	Lo / Med / Hi	dB(A)	51 / 54 / 58	54 / 56 / 57	54 / 56 / 57	53 / 54 / 57	53 / 54 / 57	53 / 56 / 58	53 / 56 / 58	54 / 56 / 58	54 / 56 / 58	55 / 59 / 63	55 / 59 / 63	55 / 59 / 63	57 / 60 / 63	55 / 59 / 62	70 / 69 / 68	70 / 69 / 68	72 / 69 / 70
NR	Lo / Med / Hi		34 / 37 / 40	33 / 34 / 37	33 / 34 / 37	33 / 35 / 38	33 / 35 / 38	34 / 37 / 41	34 / 37 / 41	36 / 40 / 43	36 / 40 / 43	39 / 43 / 46	39 / 43 / 46	39 / 43 / 46	36 / 39 / 44	36 / 39 / 44	56 / 54 / 52	56 / 54 / 52	56 / 53 / 50
<b>Dimension</b>																			
Length	mm	900	1050	1050	1050	1050	1050	1250	1250	1250	1250	1250	1250	1250	1680	1680	1680	1680	
Width	mm	600	600	660	660	660	660	705	705	705	705	705	705	705	955	955	955	955	
Height	mm	439	460	460	460	460	460	513	513	513	513	513	583	513	770	770	770	770	
<b>Weight</b>																			
Operating weight	kg	80	100	112	100	100	112	133	133	135	140	144	149	149	253	253	259	262	

1) \*\*\* HWA: units without RCS, HRA: units with RCS, HBA: units with RCS + EH, HHA: units with EH. 2) Nominal cooling capacities based on: entering air temperature of 27 °C DB, 19 °C WB with entering water temperature of 30 °C. 3) Nominal heating capacities based on: entering air temperature of 20 °C DB, 15 °C WB with entering water temperature of 20 °C. 4) Absorbed power (compressor + fan) at nominal conditions. Check data and configuration on the technical documentation.

Accessories and options

Circuit breaker
Controller with BACnet MSTP (LON and Modbus TCP/IP available upon request)
EH - Electric heaters
General alarm dry contact
Main switch

Accessories and options

Motorized water valve
RCS remote control (for controller with protocol communication)
Room sensor
SRC - mini BMS controller
G3 filter (available upon request)





# ECOi-LOOP FS H · R407C

Water source heat pumps reversible.

Cooling capacity: 1,9 to 2,7 kW.

Heating capacity: 2,4 to 3,2 kW.



Optional controller.  
RCS remote control.



Optional controller.  
SRC - mini BMS controller.



SEE PAGE 562 FOR MORE DETAILS ABOUT WATER SOURCE HEAT PUMPS CONTROL SYSTEMS

## Operating limits

Air inlet temperature.

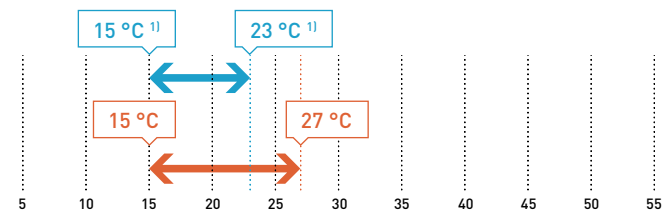

Water inlet temperature.

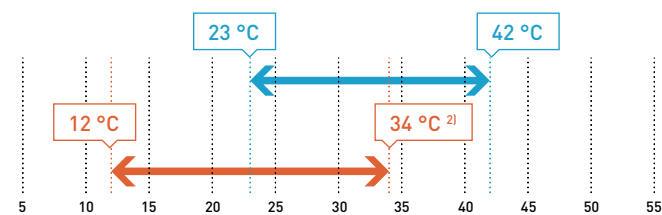

1) From 21 to 32 °C DB. 2) 32 °C for ECOi-LOOP FS 07 in low speed. \* Maximum water pressure 10 bars.

## The range at a glance

- 1 version: H (reversible)
- 1 size
- Vertical installation
- 4 versions: VC (standard version with cabinet), VCL (low height version with cabinet), VN (standard version without cabinet) and VNL (low height version without cabinet)
- EER up to 3,25 and COP up to 3,49
- Nominal air flow from 400 to 510 m<sup>3</sup>/h
- 3-speed AC fan (or optional low consumption EC fan)
- Many hydraulic and electric configurations available
- Front or bottom air intake
- Operating range: from 15 °C to 32 °C ambient air temperature
- Water inlet temperature from 12 °C to 42 °C

## Advantages

- Low sound levels: acoustic insulation between ventilation and compressor compartments
- Design and elaborate finish cabinet enabling harmonious integration (RAL9010)
- Low energy consumption EC fan (option)
- Highly customisable. Many air routing configurations and selection of hydraulic service side
- Easy access to components through a removable front panel
- Brazed stainless steel plate heat exchanger for improved efficiency
- 100% factory tested

## Equipment

- The refrigerant circuit comprises a rotary type hermetic compressor, a cycle reversal valve, a water/refrigerant heat exchanger, a liquid receiver, a finned coil, HP and LP pressure switches and 2 Schrader valves (HP and LP)
- The rotary type hermetic compressor, mounted on spring anti-vibration mounts, is integrated in a compartment coated with reinforced acoustic insulation. It is also equipped with internal thermal protection
- The units are equipped with a control system (POL423) utilising Modbus RTU
- The water/refrigerant heat exchanger is made of brazed stainless steel plates, for improved efficiency
- RAL9010 painted cabinet for versions VC and VCL
- Condensate drain pan with an anti-corrosion treatment
- A G2 air filter is provided within the unit

## AC SELECT.

Smart and user-friendly the new air conditioning selection program: <https://acselect.panasonic.eu/>





## Technical features

ECOi-LOOP FS H - reversible		P-LPFSM12HA	
Total cooling capacity <sup>1)</sup>	W	2743	
Sensible cooling capacity <sup>1)</sup>	W	2340	
EER		3,25	
Heating capacity <sup>2)</sup>	W	3156	
COP		3,49	
<b>Ventilation</b>			
Number of fans		1	
Air flow	Lo / Med / Hi	m <sup>3</sup> /h	400 / 460 / 510
Motor power (with AC / EC fan)		W	75 / 40
Air filter	Number / efficiency		1 / G2
<b>Hydraulic circuit</b>			
Number of plate heat exchanger		1	
Maximum water pressure	bar	10	
Nominal water flow	l/h	616	
WPD at nominal water flow	kPa	12	
Connections - inlet/outlet (ø)	Inch	ISO G ½ INT	
Condensate outlet - external (Ø)	mm	15 x 20	
<b>Refrigerant circuit</b>			
Number of refrigerant circuits		1	
Compressor type		Rotary	
Load	g	750	
<b>Electrical data</b>			
Power supply	Voltage	V	230
	Phase		Single phase
	Frequency	Hz	50 ±10%
Input power - AC fan <sup>3)</sup>	Cooling	W	892
	Heating	W	954
<b>Sound levels - AC fan</b>			
Sound pressure <sup>4)</sup>	Lo / Med / Hi	dB(A)	43 / 45 / 46
NR <sup>4)</sup>	Lo / Med / Hi		38 / 40 / 41
<b>Dimension</b>			
Standard with cabinet (VC)	LxWxH	mm	1138 x 251 x 720 min / 750 max (821 with feet)
Low height with cabinet (VCL)	LxWxH	mm	1323 x 251 x 580 min / 610 max (683 with feet)
Standard without cabinet (VN)	LxWxH	mm	1043,5 (1086 with feet) x 229 x 667,5 min / 697,5 max (769,5 with feet)
Low height without cabinet (VNL)	LxWxH	mm	1182,5 (1183 with feet) x 229 x 525 min / 555 max (627 with feet)
<b>Weight</b>			
Without cabinet / with cabinet - operating		kg	60 / 75

1) Nominal cooling capacities based on: entering air temperature of 27 °C DB/19 °C WB, with entering water temperature of 30 °C. 2) Nominal heating capacities based on: entering air temperature of 20 °C DB/15 °C WB, with entering water temperature of 20 °C. 3) Absorbed power (compressor + fan) at nominal conditions. 4) Sound pressure considering a local of 100 m<sup>3</sup>, a reverberation time of 0,5 sec and a distance of 1 m.

### Accessories and options

Controller with BACnet MSTP (LON and Modbus TCP/IP available upon request)
EC fan
Feet
General remote alarm contact
Low noise

### Accessories and options

Many electric, hydraulic and aeraulic configurations
RCS remote control (for controller with protocol communication)
SRC - mini BMS controller
Thermal overload





# ECOi-LOOP-N FS H · R513A

Water source heat pumps reversible.

Cooling capacity: 1,7 to 2,0 kW.

Heating capacity: 1,8 to 2,6 kW.



Optional controller.  
RCS remote control.



Optional controller.  
SRC - mini BMS controller.

+ SEE PAGE 562 FOR MORE DETAILS ABOUT WATER SOURCE HEAT PUMPS CONTROL SYSTEMS

## Operating limits

Air inlet temperature.

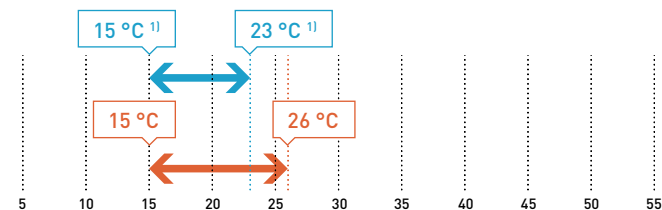

Water inlet temperature.

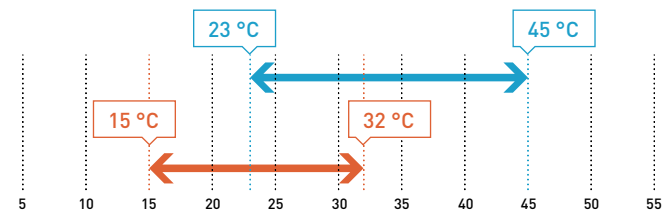

1) From 21 to 32 °C DB. \* Maximum water pressure 10 bars.

## The range at a glance

- 1 version: H (reversible)
- 2 sizes
- Vertical installation
- 4 versions: VC (standard version with cabinet), VCL (low height version with cabinet), VN (standard version without cabinet) and VNL (low height version without cabinet)
- EER up to 4,9 and COP up to 4,6
- Nominal air flow from 250 to 460 m<sup>3</sup>/h
- 3-speed AC fan (or optional low consumption EC fan)
- Many hydraulic and electric configurations available
- Front or bottom air intake
- Operating range: from 15 °C to 32 °C ambient air temperature
- Water inlet temperature from 15 °C to 45 °C

## Advantages

- Low sound levels: acoustic insulation between ventilation and compressor compartments
- Design and Elaborate finish cabinet enabling harmonious integration (RAL9010)
- Low energy consumption EC fan (option)
- Highly customisable. Many air routing configurations and selection of hydraulic service side
- Easy access to components through a removable front panel
- Brazed stainless steel plate heat exchanger for improved efficiency (coaxial exchanger upon request)
- 100% factory tested

## Equipment

- The refrigerant circuit comprises a rotary type hermetic compressor, a cycle reversal valve, a water/refrigerant heat exchanger, a liquid receiver, a capillary expansion device, a finned coil, HP and LP pressure switches and 2 Schrader valves (HP and LP)
- The rotary type hermetic compressor is installed in a compartment covered with a 20 mm thick Isofeutre thermal-acoustic insulation. It is also equipped with internal thermal protection
- The units are equipped with a control system (POL423) utilising Modbus RTU
- The water/refrigerant heat exchanger is made of brazed stainless steel plates, for improved efficiency. A coaxial heat exchanger is available on request
- RAL9010 painted cabinet for versions VC and VCL
- Condensate drain pan with an anti-corrosion treatment
- A G2 air filter is provided within the unit

## AC SELECT.

Smart and user-friendly the new air conditioning selection program: <https://acselect.panasonic.eu/>





## Technical features

ECOi-LOOP-N FS H - reversible			P-LPFSN07HA	P-LPFSN09HA
Total cooling capacity <sup>1)</sup>	W		1690	2040
Sensible cooling capacity <sup>1)</sup>	W		1410	1600
Input power (with EC / AC fan) <sup>2)</sup>	W		345 / 355	480 / 487
EER according to EN14511 (with EC / AC fan)			4,9 / 4,75	4,25 / 4,19
Heating capacity <sup>3)</sup>	W		1790	2630
Input power (with EC / AC fan) <sup>2)</sup>	W		395 / 405	610 / 617
COP according to EN14511 (with EC / AC fan)			4,6 / 4,41	4,31 / 4,26
<b>Ventilation</b>				
Air flow	Min	m <sup>3</sup> /h	250	340
	Nominal	m <sup>3</sup> /h	340	400
	Max	m <sup>3</sup> /h	400	460
Nominal input power (with EC / AC fan)	W		15 / 25	20 / 27
Motor power (with EC / AC fan)	W		40 / 75	40 / 75
Air filter	Number / efficiency		1 / G2	1 / G2
<b>Hydraulic circuit</b>				
Number of plate heat exchanger			1	1
Maximum water pressure	Bar		10	10
Nominal water flow	Cooling <sup>1)</sup>	l/h	351	434
	Heating <sup>3)</sup>	l/h	405	586
Cutoff water flow		l/h	180	180
WPD at nominal water flow	Cooling <sup>1)</sup>	kPa	3,8	5,8
	Heating <sup>3)</sup>	kPa	5,1	10,8
Hydraulic connections - inlet/outlet	Inch		Female ISO G ½ INT	Female ISO G ½ INT
Condensate outlet (Ø)	mm		15 x 20	15 x 20
<b>Refrigerant circuit</b>				
Number of refrigerant circuits			1	1
Type of compressor			Rotary	Rotary
Load	g		500	490
<b>Electrical data</b>				
Power supply	Voltage	V	230	230
	Phase		Single phase	Single phase
	Frequency	Hz	50 ±10%	50 ±10%
Maximum current <sup>4)</sup>	A		4,6	5,7
Starting current <sup>5)</sup>	A		16	16,5
<b>Sound levels</b>				
Sound power Lw	Lo / Med / Hi	dB(A)	47,2 / 49,8 / 51,5	49,8 / 51,5 / 54,3
Sound pressure Lp	Lo / Med / Hi	dB(A)	38,2 / 40,8 / 42,5	40,8 / 42,5 / 45,3
NR	Lo / Med / Hi	dB(A)	32 / 34 / 36	34 / 36 / 40
<b>Sound levels - extra low noise version</b>				
Sound power Lw	Lo / Med / Hi	dB(A)	42,5 / 44,6 / 46,5	44,7 / 46,5 / 48,6
Sound pressure Lp	Lo / Med / Hi	dB(A)	33,5 / 35,6 / 37,5	35,7 / 37,5 / 39,6
NR	Lo / Med / Hi	dB(A)	28 / 30 / 32	30 / 32 / 34
<b>Dimension</b>				
Standard with cabinet (VC)	LxWxH	mm	1138 x 260 x 720 min / 750 max (821 with feet)	1138 x 260 x 720 min / 750 max (821 with feet)
Low height with cabinet (VCL)	LxWxH	mm	1322 x 260 x 582 min / 612 max (683 with feet)	1322 x 260 x 582 min / 612 max (683 with feet)
Standard without cabinet (VN)	LxWxH	mm	1055 (1084 with feet) x 241 x 667 min / 697 max (769 with feet)	1055 (1084 with feet) x 241 x 667 min / 697 max (769 with feet)
Low height without cabinet (VNL)	LxWxH	mm	1185 (1270 with feet) x 241 x 525 min / 555 max (626 with feet)	1185 (1270 with feet) x 241 x 525 min / 555 max (626 with feet)
<b>Weight</b>				
Without cabinet / with cabinet - operating	kg		55 / 70	58 / 73

1) Nominal cooling capacities based on: entering air temperature of 27 °C DB/19 °C WB, with entering water temperature of 30 °C. 2) Absorbed power (compressor + fan) at nominal conditions. 3) Nominal heating capacities based on: entering air temperature of 20 °C DB/15 °C WB, with entering water temperature of 20 °C. 4) Maximum currents are given at +/- 5%. 5) Starting currents are given at +/- 10%.

### Accessories and options

Controller with BACnet MSTP (LON and Modbus TCP/IP available upon request)
EC fan
Feet
General remote alarm contact
Low noise

### Accessories and options

Many electric, hydraulic and aeraulic configurations
RCS remote control (for controller with protocol communication)
SRC - mini BMS controller
Thermal overload



# Water source heat pumps control systems



## SRC - mini BMS controller

### Smart controller. Mini building management system.

With the SRC - mini BMS controller - you can now remotely control multiple units or zones of units with a single interface.

Its time programming function offers you the possibility to fully control and rationalise the energy consumption of your HVAC system.

This smart controller is intuitive and easy to use thanks to its color touch screen, logical structure and clear control icons.

The modern and refined design fits perfectly in to any modern interior.

- Supervise fan coil units, chillers/heat pumps, air handling units and water source heat pumps
- Manage up to 31 units
- Communicate via Modbus protocol
- Time programming function
- A modern and refined design
- 3,5" color touch screen
- Wall mounting

### Used as a mini BMS.

With the SRC you can create up to 15 zones including several Panasonic units belonging to the same product lines.

- Chillers / heat pumps
- Air handling units
- Fan coil units

### Used as a remote control.

The SRC can also control, in a unique zone, one or several units belonging to the same product line.

- Fan coil units
- Water source heat pumps



## Control system with protocol communication

### Ventilation:

- Compatibility: 3-speed AC fan motor or EC fan motor
- Manual speed (3 levels)
- Automatic speed

### Communication:

- Modbus RTU or BACnet MSTP
- Modbus TCP/IP or LON or BACnet IP upon request

### Operating mode:

- OFF / Comfort / ECO

### Function type:

- Summer
- Winter
- Ventilation
- Auto changeover (adjustment of the automatic mode according to the setpoint)

### Setpoint:

- Extract air temperature
- Room thermostat
- BMS



## RCS remote control

### Main functions:

- ON / OFF
- Comfort / ECO modes
- Operating mode setting
- Setpoint adjustment
- Room temperature (OFF)
- Ventilation setting (manual or automatic)
- Time display and setting
- Alarm summary
- Zoning (up to 15 units)
- Scheduling



## Rooftops

A complete mono-bloc solution for large buildings.

With rooftop units, you get a complete compact and mono-bloc solution to heat and cool large buildings such as shopping centers, industries or airports that need high capacities. It is an easy to install, space saving solution, directly on the roof or close to a building.



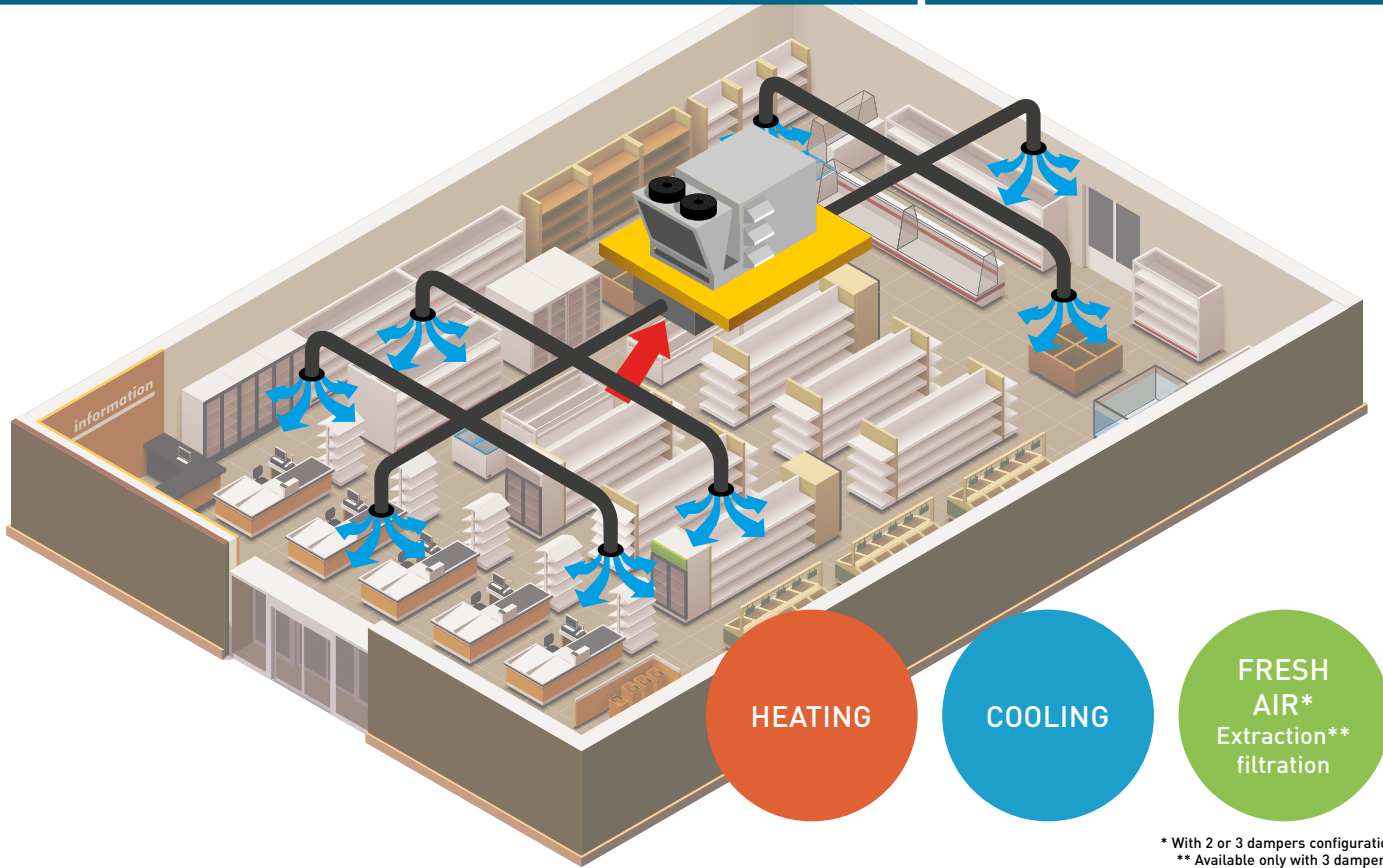

\* With 2 or 3 dampers configurations.  
 \*\* Available only with 3 dampers configuration.



Self-contained solution, compact and mono-bloc.



Capacity range from 50 to 220 kW.

R410A  
R32

Refrigerants: R410A / R32.

HIGH SEER HIGH SCOP

High SEER and SCOP.

HIGH ESP

Very high external static pressure.

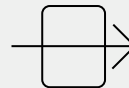

Extractible drain pan.



Many configurations and options.

Ecodesign

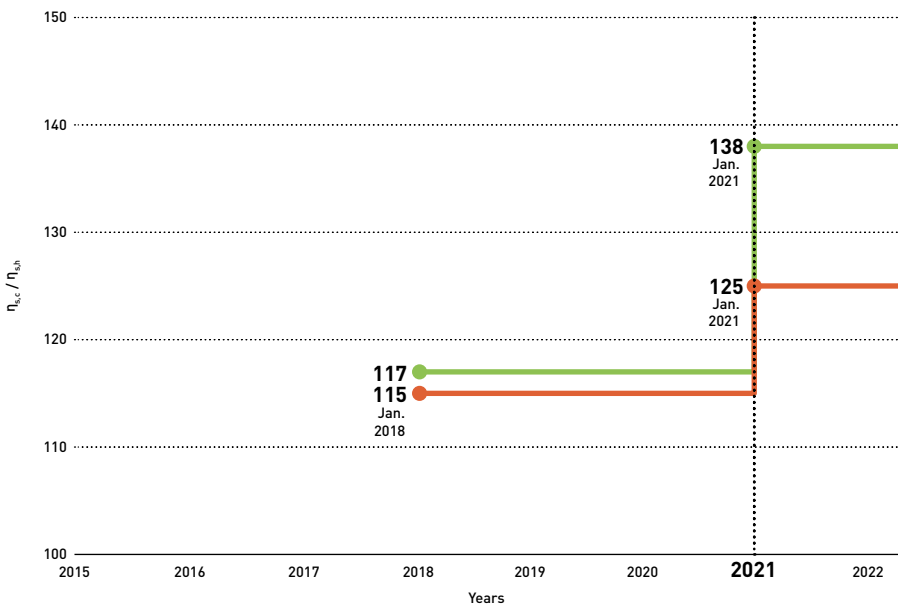

Air to air rooftops cooling only.

Minimum  $\eta_{ec}$  to be Ecodesign compliant. COMMISSION REGULATION (EU) 2016/2281.

Air to air rooftops reversible.

Minimum  $\eta_{e,h}$  to be Ecodesign compliant. COMMISSION REGULATION (EU) No813/2013.

## Quick selection guide - Rooftops cooling only

Page	Size	Cooling capacity (kW)	Nominal air flow (m <sup>3</sup> /h)	Sound power (two - dB(A))	Dimension L x H x W (mm)
P. 570	55	49,60	9720	80	3250 x 1800 x 2030
	65	62,80	11500	83	3250 x 1800 x 2030
	80	79,00	14300	80	3250 x 1800 x 2030
	95	89,27	17500	85	3740 x 2110 x 2285
	105	111,08	19200	85	3740 x 2110 x 2285
	120	119,87	21500	87	3740 x 2110 x 2285
	140	142,09	25500	91	3740 x 2110 x 2285
	160	164,98	28000	91	5505 x 2110 x 2285
	190	197,06	30000	92	5505 x 2110 x 2285
	210	219,12	32000	94	5505 x 2110 x 2285



## Quick selection guide - Rooftops reversible

Page	Size	Cooling and heating capacity (kW)	Nominal air flow (m <sup>3</sup> /h)	Sound power (two - dB(A))	Dimension L x H x W (mm)
P. 568	105	106,0 106,0	19200	79,8	3740 x 2150 x 2285
	120	119,0 117,0	21500	79,8	3740 x 2150 x 2285
	140	139,0 142,0	25500	86,1	3740 x 2150 x 2285
	160	160,1 157,9	28000	91	5505 x 2110 x 2285
P. 570	55	48,1 50,7	9720	80	3250 x 1800 x 2030
	65	61,0 59,7	11500	83	3250 x 1800 x 2030
	80	76,7 76,6	14300	80	3250 x 1800 x 2030
	95	87,2 90,7	17500	85	3740 x 2110 x 2285
	105	107,8 107,0	19200	85	3740 x 2110 x 2285
	120	116,3 117,1	21500	87	3740 x 2110 x 2285
	140	137,9 148,7	25500	91	3740 x 2110 x 2285
	160	160,1 157,9	28000	91	5505 x 2110 x 2285
	190	191,2 187,3	30000	92	5505 x 2110 x 2285
	210	212,6 214,4	32000	94	5505 x 2110 x 2285



R32



\* Heat pump version with EC fans.

# Energy recovery system configurations

## RECO - standard energy recovery (3 dampers)

Energy recovery on the exhaust air.

	Pc	EER	Ph	COP
<b>3 dampers + RECO 30% fresh air</b>	+1%	+2%	+7%	+4%
<b>3 dampers + RECO 60% fresh air</b>	+2%	+4%	+14%	+8%

\* Nominal conditions. Pc: cooling capacity / Ph: heating capacity.

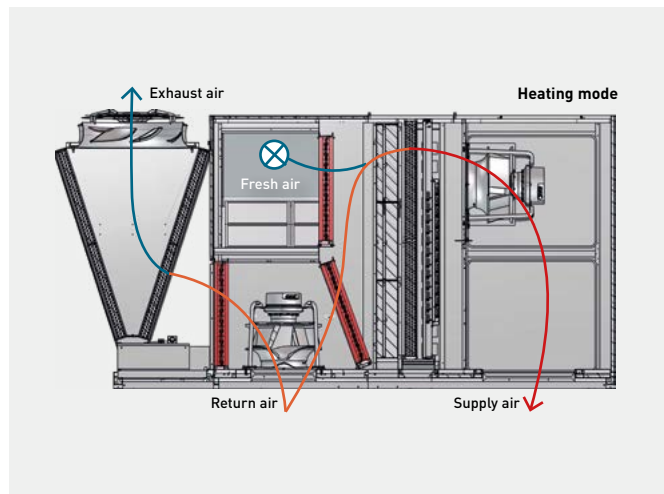

## TRECO - thermodynamic energy recovery (3 dampers)

Active energy recovery between the exhaust air and the fresh air using dedicated thermodynamic system.

	Pc	EER	Ph	COP
<b>3 dampers + TRECO 20% fresh air</b>	+21%	0%	+20%	+3%
<b>3 dampers + TRECO 60% fresh air</b>	+20%	-2%	+21%	+4%

\* Nominal conditions. Pc: cooling capacity / Ph: heating capacity.  
\*\* TRECO is not available for the R32 rooftops.

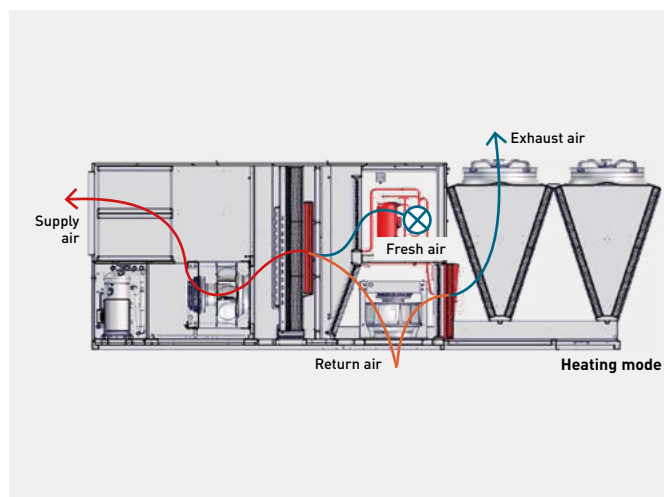

## Supply and return air configurations

<b>Supply air</b>	S1 bottom side supply air
	S2 left side supply air
	S3 front side supply air
	S4 top side supply air
<b>Return air</b>	R1 bottom side return air
	R2 left side return air
	R4 top side return air <sup>1)</sup>

1) Not available with the 3 dampers - RECO system configuration.

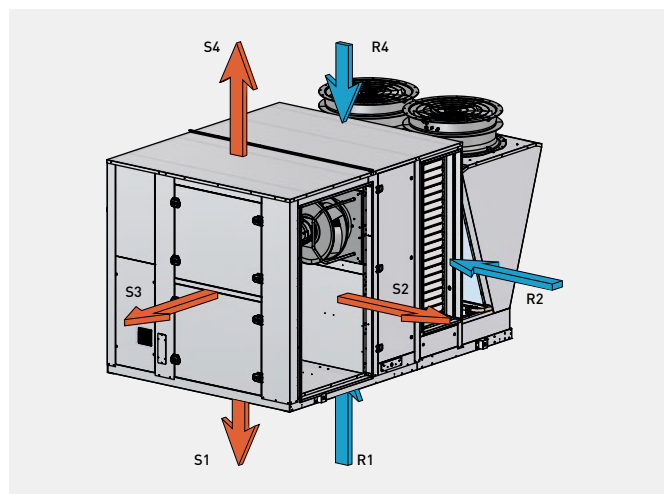

## AC SELECT.

Smart and user-friendly the new air conditioning selection program: <https://acselect.panasonic.eu/>





# ECOi-RT-Z H · R32

Rooftop reversible units.

**Cooling capacity: 106 to 139 kW.**  
**Heating capacity: 106 to 142 kW.**



**CO<sub>2</sub> carbon footprint  
reduced by -80%\***

\* Impact considering only the refrigerants  
and not the units as a whole.

**R32**  
REFRIGERANT

## The range at a glance

- Reversible version
- SEER up to 3,8 and SCOP up to 3,56
- 3 sizes
- Nominal air flow from 19200 to 25500 m<sup>3</sup>/h
- Additional heaters available
- Many supply and return air configurations
- 1 energy recovery system configuration (RECO)

## Advantages

- Low GWP R32 refrigerant (GWP= 675)
- Very low sound levels
- Safety ventilation system
- Low energy consumption EC fans
- Many supply and return air configurations
- Thermal/acoustic insulation: double skin (25 mm glasswool)
- Dehumidification function (option)
- 100% factory tested

## Equipment

- 2 refrigerant circuits for an optimised defrost logic. They are both completely closed in a separate compartment to reduce noise level. Each circuit comprises of 1 Scroll compressor covered with a sound jacket, Indoor and outdoor coils, 4 way reversing valve, filter dryer, sight glass, thermostatic expansion valve, high and low pressure switches, defrosting pressure switch, and temperature sensors
- 2 Scroll compressors - 1 per circuit - covered with sound jackets. Each compressor is equipped with a crankcase heater and mounted on rubber pads to eliminate noise and vibration transmissions. The motors are equipped with an overload protection and have direct start-up. A phase sequence monitor is supplied as standard
- The new advanced control system includes, among others, Modbus protocols, optimised defrost logic, very high security envelope, Modbus control of the indoor fans, and a dehumidification function. The controls are grouped and wired in the unit, factory tested and shipped READY TO USE. They are located in a sealed compartment isolated from the air flow. The electrical equipment is compliant with EC standards and EN60204-1
- The outdoor and indoor heat exchangers are made of seamless copper tubes mechanically expanded into aluminium fins. They have a highly optimised design providing a refrigerant charge reduction of 40% (compared to a unit operating with R410A). Outdoor coils are largely dimensioned to optimise performance and defrost cycles. They are also equipped with a protective grille to prevent shocks - Bluefin treatment
- The unit casing is of heavy duty galvanized steel, painted with a special process to ensure a perfect protection against corrosion (RAL 9001). The complete unit is covered with double skin panels to ensure perfect thermal insulation. For full unit access, all service panels are removable. Under the indoor heat exchanger, an extractable condensate drain pan allows hygienic cleaning
- The indoor fans are plug fan type with EC motors
- A safety ventilation system ensures venting of the refrigerant gas to atmosphere in case of leak

## Operating limits

To be confirmed with AC SELECT:  
<https://acselect.panasonic.eu/>

Ambient temperature (DB).

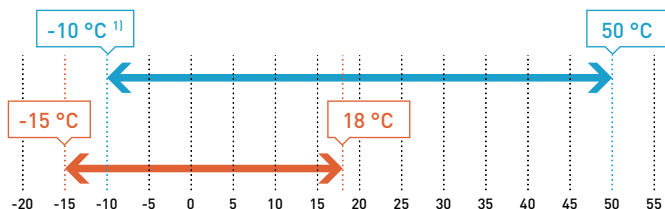

Temperature before indoor coil <sup>2</sup>.

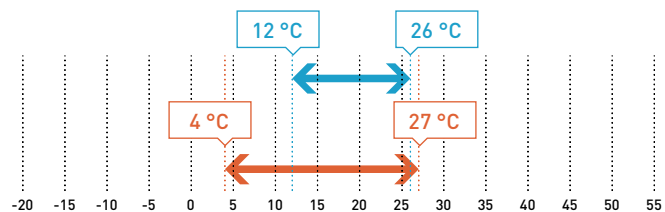

1) Using fan speed control option. 2) Cooling: °C (WB). Heating: °C (DB).

### Accessories and options

2 dampers - for external air inlet
3 dampers RECO - return EC plug fans included (HPF or LFP) + Recovery
Adjustable roofcurb
Anti-vibration mounts
Clogged filter sensor (1 or 2 stages)
Compressor soft starter
Container transportation compatibility
Dehumidification function
Electric heater 48 kW

### Accessories and options

Energy meter
Fan speed control
G4, G4+F7 or G4+F9 filters
Hot water coil
Local and additional remote keyboard
Many aeraulic configurations
Room temperature sensor
Sensors [enthalpy, CO <sub>2</sub> ]
Smoke detector
Supply EC LPF plug fans



## Technical features

Size		105	120	140
<b>ECOi-RT-Z H - reversible</b>		<b>P-RTZ0105HA</b>	<b>P-RTZ0120HA</b>	<b>P-RTZ0140HA</b>
Cooling capacity <sup>1)</sup>	kW	106	119	139
Input power <sup>1)</sup>	kW	31,5	36,8	43,0
EER <sup>1)</sup>		3,37	3,23	3,24
<b>Pdesign <sup>2) 3)</sup></b>	<b>kW</b>	<b>106</b>	<b>119</b>	<b>139</b>
<b>SEER <sup>2) 3)</sup></b>		<b>3,82</b>	<b>3,82</b>	<b>3,67</b>
<b>Energy efficiency class <sup>2) 3)</sup></b>	<b>A+ to E</b>	<b>B</b>	<b>B</b>	<b>B</b>
$\eta_{s,c}$ <sup>2) 3)</sup>		<b>150</b>	<b>150</b>	<b>144</b>
Heating capacity <sup>1)</sup>	kW	106	117	142
Input power <sup>1)</sup>	kW	27,0	30,3	38,0
COP <sup>1)</sup>		3,72	3,89	3,69
<b>Pdesign <sup>2) 3)</sup></b>	<b>kW</b>	<b>100</b>	<b>118</b>	<b>140</b>
<b>SCOP <sup>2) 3)</sup></b>		<b>3,36</b>	<b>3,56</b>	<b>3,32</b>
<b>Energy efficiency class <sup>2) 3)</sup></b>	<b>A+ to E</b>	<b>B</b>	<b>B</b>	<b>B</b>
$\eta_{s,h}$ <sup>2) 3)</sup>		<b>131</b>	<b>130</b>	<b>130</b>
<b>Electrical data</b>				
Power supply	Voltage	V	400	400
	Phase		Three phase	Three phase
	Frequency	Hz	50	50
Maximum operating intensity	A	79,0	85,0	105,0
<b>Refrigerant and compressors</b>				
Number of refrigerant circuits		2	2	2
Compressors	Number / type	2 / Scroll	2 / Scroll	2 / Scroll
Mounting type		Single	Single	Single
Capacity steps	%	0 / 50 / 100	0 / 50 / 100	0 / 50 / 100
<b>Indoor coil</b>				
Coil type		Copper tubes and aluminium fins	Copper tubes and aluminium fins	Copper tubes and aluminium fins
Number of rows		4	4	4
Front surface		m <sup>2</sup>	3,24	3,24
<b>Outdoor coil</b>				
Coil type		Copper tubes and aluminium fins	Copper tubes and aluminium fins	Copper tubes and aluminium fins
Number of rows		3	3	3
Front surface		m <sup>2</sup>	1,50	1,50
<b>Indoor fans - EC type</b>				
Fan type		Backward curved centrifugal	Backward curved centrifugal	Backward curved centrifugal
Number of fans		2	2	2
Air flow rate	Min. / Nominal / Max.	m <sup>3</sup> /h	15360 / 19200 / 23040	17200 / 21500 / 25800
Motor power		kW	4,23	4,60
<b>Outdoor fans</b>				
Fan		Number / type	2 / Axial	2 / Axial
Motor power		kW	1,51	1,51
<b>Sound levels</b>				
Sound power		dB(A)	79,8	79,8
Supply sound power		dB(A)	84,2	84,2
Sound pressure at 10 m		dB(A)	48,8	48,8
<b>Dimension and weight</b>				
Dimension	Length total / floor	mm	3740 / 3295	3740 / 3295
	Width / Height	mm	2285 / 2150	2285 / 2150
Weight (without option)		kg	1685	1805

1) Following EN 14511 2018. 2) Following EN 14825 2017. 3) Following COMMISSION REGULATION (EU) 2016/2281.

### ECOi-RT-Z H · R32 units are available in 3 configurations:

- No damper: unit working with 100% recycled air
- 2 dampers: with outdoor air inlet
- 3 dampers - RECO system: energy recovery system on the exhaust air. This configuration is equipped with 2 return EC plug fans





# ECOi-RT C/H · R410A

Rooftop cooling only and reversible units.

Cooling capacity: 48,1 to 219,1 kW.

Heating capacity: 50,7 to 214,4 kW.



## Operating limits

To be confirmed with AC SELECT:

<https://acselect.panasonic.eu/>

### Ambient temperature (DB).

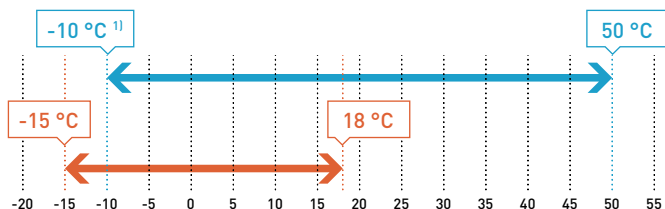

### Temperature before indoor coil <sup>2</sup>.

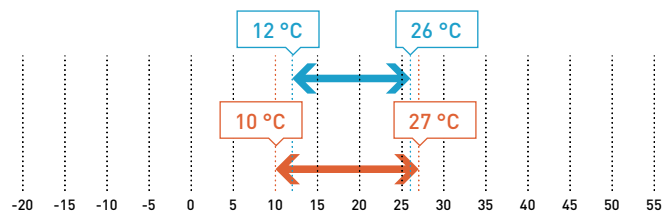

1) Using fan speed control option. 2) Cooling: °C (WB). Heating: °C (DB).

### Accessories and options

AC HP plug fan
Adjustable roof curb
Anti-vibration mounts
Clogged filter sensor (1 or 2 stages)
Compatible container transportation
Compressor soft starter
EC or EC HP plug fan
Electric heaters
Energy recovery system
Epoxy treatment (indoor/outdoor coils)
Fan speed control

### Accessories and options

G4, G4+F7 or G4+F9 filters
Gas heater
Hot water coil
Local additional remote keyboard
Many aeratic configurations (bottom, side, front, top)
Modbus / BACnet
RECO or TRECO energy recovery
Room temperature sensor
Sensors (VOC, enthalpy, CO <sub>2</sub> )
Smoke detector

## The range at a glance

- 2 versions: C (cooling only) and H (reversible)
- SEER up to 3,94 and SCOP up to 3,23
- 10 sizes
- Nominal air flow from 9720 to 32000 m<sup>3</sup>/h
- Additional heaters available
- Many aeratic configurations
- 2 energy recovery system configurations (RECO and TRECO)

## Advantages

- Very high performances: A class EER and COP
- Low energy consumption EC fans
- Wide operating limits
- Thermal/acoustic insulation: double skin (25 mm glasswool)
- 100% factory tested

## Equipment

- 2 refrigerant circuits for optimised defrosting logic. They are both completely closed in a separate compartment to reduce noise level. Each circuit comprises of Scroll compressor(s) (2 per circuit from size 160), indoor and outdoor coils, 4 way reversing valve (H type), filter dryer, sight glass, thermostatic or electronic expansion valve (from 160 to 210), high and low pressure switches, defrosting pressure switch, intake temperature sensor, and a liquid accumulation bottle (for sizes from 160 to 210)
- 2 or 4 Scroll compressors - 1 per circuit from 55 to 140 and 2 per circuit for 160 to 210 assembled together in tandem. Each compressor is equipped with a crankcase heater and mounted on rubber pads to eliminate noise and vibration transmissions. The motors are equipped with overload protection and have direct start-up. A phase sequence monitor is supplied as standard
- The controls are grouped and wired in the unit, factory tested and shipped READY TO USE. They are located in a sealed compartment that is isolated from the air flow. The electrical equipment is compliant with EC standards and EN60204-1
- The outdoor and indoor heat exchangers are made of seamless copper tubes mechanically expanded into aluminium fins. Outdoor coils are largely dimensioned to optimise performance and defrost cycles. They are also equipped with a protective grille to prevent shocks - Bluefin treatment applicable to reversible type
- The unit casing is of heavy duty galvanized steel, painted with a special process to ensure a perfect protection against corrosion (RAL 9001). The complete unit is covered with double skin panels to ensure perfect thermal insulation. For full unit access, all service panels are removable. Under the indoor heat exchanger, an extractable condensate drain pan allows hygienic cleaning
- The indoor fan(s) are plug type with AC or EC motors; low pressure or high pressure according to the configuration selected by the customer.



Technical features

Size		55	65	80	95	105	120	140	160	190	210
<b>ECOi-RT C EC fan - cooling only</b>	<b>P-RTE****CA</b>	<b>0055</b>	<b>0065</b>	<b>0080</b>	<b>0095</b>	<b>0105</b>	<b>0120</b>	<b>0140</b>	<b>0160</b>	<b>0190</b>	<b>0210</b>
Cooling capacity <sup>1)</sup>	kW	49,60	62,80	79,00	89,27	111,08	119,87	142,09	164,98	197,06	219,12
Input power <sup>1)</sup>	kW	15,85	19,44	23,24	28,80	33,56	37,10	47,09	51,19	60,61	71,54
EER <sup>1)</sup>		3,13	3,23	3,40	3,10	3,31	3,23	3,02	3,22	3,25	3,06
<b>Pdesign <sup>2)3)</sup></b>	<b>kW</b>	<b>49,57</b>	<b>62,81</b>	<b>79,00</b>	<b>95,10</b>	<b>111,08</b>	<b>119,87</b>	<b>142,09</b>	<b>164,98</b>	<b>197,06</b>	<b>219,12</b>
<b>SEER <sup>2)3)</sup></b>		<b>3,57</b>	<b>3,58</b>	<b>3,74</b>	<b>3,54</b>	<b>3,66</b>	<b>3,57</b>	<b>3,52</b>	<b>3,91</b>	<b>3,94</b>	<b>3,71</b>
<b>Energy efficiency class <sup>2)3)</sup></b>	<b>A+ to E</b>	<b>B</b>	<b>B</b>	<b>B</b>	<b>B</b>	<b>B</b>	<b>B</b>	<b>B</b>	<b>B</b>	<b>B</b>	<b>B</b>
$\eta_{s,c}$ <sup>2)3)</sup>		<b>140</b>	<b>140</b>	<b>147</b>	<b>139</b>	<b>143</b>	<b>140</b>	<b>138</b>	<b>154</b>	<b>154</b>	<b>145</b>
<b>ECOi-RT H EC fan - reversible</b>	<b>P-RTE****HA</b>	<b>0055</b>	<b>0065</b>	<b>0080</b>	<b>0095</b>	<b>0105</b>	<b>0120</b>	<b>0140</b>	<b>0160</b>	<b>0190</b>	<b>0210</b>
Cooling capacity <sup>1)</sup>	kW	48,10	61,00	76,70	87,21	107,81	116,34	137,88	160,10	191,21	212,60
Input power <sup>1)</sup>	kW	15,82	19,49	23,24	28,97	33,56	37,10	45,69	51,19	60,61	70,47
EER <sup>1)</sup>		3,04	3,13	3,30	3,01	3,21	3,14	3,02	3,13	3,15	3,02
<b>Pdesign <sup>2)3)</sup></b>	<b>kW</b>	<b>48,12</b>	<b>60,95</b>	<b>76,67</b>	<b>92,34</b>	<b>107,81</b>	<b>116,34</b>	<b>137,88</b>	<b>160,10</b>	<b>191,21</b>	<b>212,60</b>
<b>SEER <sup>2)3)</sup></b>		<b>3,53</b>	<b>3,52</b>	<b>3,63</b>	<b>3,52</b>	<b>3,55</b>	<b>3,52</b>	<b>3,52</b>	<b>3,80</b>	<b>3,82</b>	<b>3,65</b>
<b>Energy efficiency class <sup>2)3)</sup></b>	<b>A+ to E</b>	<b>B</b>	<b>C</b>	<b>B</b>	<b>C</b>	<b>B</b>	<b>B</b>	<b>B</b>	<b>B</b>	<b>B</b>	<b>B</b>
$\eta_{s,c}$ <sup>2)3)</sup>		<b>138,12</b>	<b>137,80</b>	<b>142,20</b>	<b>137,80</b>	<b>139,17</b>	<b>138,00</b>	<b>138,00</b>	<b>148,92</b>	<b>149,82</b>	<b>143,15</b>
Heating capacity <sup>1)</sup>	kW	50,65	59,65	76,63	90,66	106,95	117,10	148,70	157,90	187,31	214,37
Input power <sup>1)</sup>	kW	14,81	17,49	21,77	26,59	30,38	34,14	42,85	46,17	54,29	62,68
COP <sup>1)</sup>		3,42	3,41	3,52	3,41	3,52	3,43	3,47	3,42	3,45	3,42
<b>Pdesign <sup>2)3)</sup></b>	<b>kW</b>	<b>48,00</b>	<b>58,00</b>	<b>67,00</b>	<b>85,00</b>	<b>100,00</b>	<b>112,00</b>	<b>145,00</b>	<b>155,00</b>	<b>180,00</b>	<b>210,00</b>
<b>SCOP <sup>2)3)</sup></b>		<b>3,20</b>	<b>3,22</b>	<b>3,22</b>	<b>3,23</b>	<b>3,22</b>	<b>3,21</b>	<b>3,20</b>	<b>3,19</b>	<b>3,23</b>	<b>3,19</b>
$\eta_{s,h}$ <sup>2)3)</sup>		<b>125,00</b>	<b>125,80</b>	<b>125,80</b>	<b>126,20</b>	<b>126,00</b>	<b>125,00</b>	<b>125,00</b>	<b>125,00</b>	<b>126,00</b>	<b>125,00</b>
<b>Electrical data</b>											
Power supply	Voltage	V	400	400	400	400	400	400	400	400	400
	Phase		Three phase	Three phase	Three phase	Three phase	Three phase	Three phase	Three phase	Three phase	Three phase
	Frequency	Hz	50	50	50	50	50	50	50	50	50
Maximum operating intensity	A	46,30	57,60	74,60	83,80	89,80	103,00	123,00	157,80	161,80	178,60
Start intensity (without soft starter)	A	156,10	175,00	184,60	225,80	276,80	290,00	347,00	266,80	303,80	365,60
Start intensity (with soft starter)	A	69,96	85,68	113,60	125,40	139,20	152,40	185,40	198,10	203,40	228,00
<b>Refrigerant and compressors</b>											
Number of refrigerant circuits		2	2	2	2	2	2	2	2	2	2
Compressors	Number / type	2 / Scroll	2 / Scroll	2 / Scroll	2 / Scroll	2 / Scroll	2 / Scroll	2 / Scroll	4 / Scroll	4 / Scroll	4 / Scroll
Mounting type		Single	Single	Single	Single	Single	Single	Single	Tandem	Tandem	Tandem
Capacity steps	%	0 / 50 / 100	0 / 50 / 100	0 / 50 / 100	0 / 50 / 100	0 / 50 / 100	0 / 50 / 100	0 / 50 / 100	0 / 25 / 50 / 75 / 100	0 / 25 / 50 / 75 / 100	0 / 25 / 50 / 75 / 100
Crankcase heater	W	2 x 70	2 x 70	2 x 70	2 x 70	2 x 70	2 x 70	2 x 120	4 x 70	4 x 70	2 x 70 - 2 x 120
<b>Indoor coil</b>											
Coil type		Copper tubes and aluminium fins	Copper tubes and aluminium fins	Copper tubes and aluminium fins	Copper tubes and aluminium fins	Copper tubes and aluminium fins	Copper tubes and aluminium fins	Copper tubes and aluminium fins	Copper tubes and aluminium fins	Copper tubes and aluminium fins	Copper tubes and aluminium fins
Number of rows		3	3	4	3	4	4	4	4	6	6
Front surface	m <sup>2</sup>	1,50	1,80	2,25	2,25	3,24	3,24	3,24	3,24	3,24	3,24
<b>Indoor fan(s) - EC type</b>											
Fan type		Backward curved centrifugal	Backward curved centrifugal	Backward curved centrifugal	Backward curved centrifugal	Backward curved centrifugal	Backward curved centrifugal	Backward curved centrifugal	Backward curved centrifugal	Backward curved centrifugal	Backward curved centrifugal
Number of fans		1	1	2	2	2	2	2	2	2	2
Air flow rate	Minimum	m <sup>3</sup> /h	7760	9200	11440	14000	15600	17200	20400	24000	27500
	Nominal	m <sup>3</sup> /h	9720	11500	14300	17500	19500	21500	25500	28000	32000
	Maximum	m <sup>3</sup> /h	11640	13800	17160	21000	23400	25800	30600	33600	38400
Motor power	kW	3,5	5,7	5,8	7	7	11,4	11,4	13,5	13,5	13,5
<b>Outdoor coil</b>											
Coil type		Copper tubes and aluminium fins	Copper tubes and aluminium fins	Copper tubes and aluminium fins	Copper tubes and aluminium fins	Copper tubes and aluminium fins	Copper tubes and aluminium fins	Copper tubes and aluminium fins	Copper tubes and aluminium fins	Copper tubes and aluminium fins	Copper tubes and aluminium fins
Number of rows		2	2	3	2	3	3	3	2	3	3
Front surface	m <sup>2</sup>	0,76	1,01	1,01	1,50	1,50	1,50	1,50	2,70	2,70	2,70
<b>Outdoor fans</b>											
Fan type		Axial	Axial	Axial	Axial	Axial	Axial	Axial	Axial	Axial	Axial
Number of fans		2	2	2	2	2	2	2	4	4	4
Diameter	mm	630	710	710	800	800	800	800	800	800	800
Air flow rate	Nominal	m <sup>3</sup> /h	9800	13000	13000	20000	20000	20000	20000	15500	15500
Motor power	kW	0,62	0,94	0,94	1,65	1,65	1,65	1,65	0,84	0,84	1,65
<b>Sound levels</b>											
Sound power (lwo) - outside	C type	dB(A)	80	83	80	85	85	87	91	91	92
	H type	dB(A)	80	83	80	81	85	87	91	91	92
Sound power (lwi) - in supply duct	dB(A)	87	94	89	90	91	95	100	91	92	88
<b>Dimension and weight</b>											
Length	Total	mm	3250	3250	3250	3740	3740	3740	3740	5505	5505
	Floor	mm	2895	2895	2895	3295	3295	3295	3295	5050	5050
Width	mm	2030	2030	2030	2285	2285	2285	2285	2285	2285	2285
Height	mm	1800	1800	1800	2110	2110	2110	2110	2110	2110	2110
Weight (without option)	kg	1085	1155	1225	1470	1685	1805	1855	2350	2555	2705

1) Following EN 14511 2018. 2) Following EN 14825 2017. 3) Following COMMISSION REGULATION (EU) 2016/2281.

ErP: ECOi-RT H and ECOi-RT C 105/160/190/210 need to be equipped with EC fans to be ErP compliant.  
Eurovent certification from size 55 to 95.

# Dimensions

## Aquarea

All in One H Series	→ 599
All in One J Series	→ 599
All in One K Series	→ 600
All in One / with Electrical Anode L Series	→ 600
All in One 2 zones L Series	→ 601
Aquarea All in One M Series	→ 601
Hydraulic module H and J Series	→ 602
Hydraulic module K Series	→ 603
Hydraulic Bi-bloc L Series	→ 603
Hydraulic Bi-bloc M Series	→ 604
Aquarea EcoFlex	→ 604
Outdoor units	→ 606
Smart fan coils	→ 610
Buffer tank	→ 611
Enamelled tanks	→ 612
Stainless steel tanks	→ 613
Heat recovery ventilation unit	→ 614
Counter flow ventilation	→ 614
DHW Stand Alone	→ 616

## Domestic

Heatcharge VZ	→ 617
Etherea	→ 618
TZ super-compact	→ 620
BZ super-compact	→ 622
UZ super-compact	→ 623
Floor console	→ 624
Low static pressure hide-away	→ 625
Indoor unit Free Multi system Z - 4 Way 60x60 cassette	→ 626
Outdoor units Free Multi System Z	→ 627
Outdoor units Multi Wall TZ	→ 628

## Commercial

Wall-mounted Professional	→ 629
Wall-mounted	→ 631
4 way 60x60 cassette	→ 632
4 way 90x90 cassette	→ 633
Ceiling	→ 634
Adaptive ducted unit	→ 637
Big PACi NX hide-away	→ 638
Big PACi hide-away	→ 639
Jet Air Stream	→ 640
Outdoor units	→ 641
PACi Water Heat Exchanger	→ 643

## VRF Systems

Mini ECOi LZ2 Series	→ 644
Mini ECOi LE2 / LE1 Series	→ 645
2-Pipe ECOi EX ME2 Series	→ 646
3-Pipe ECOi EX MF3 Series	→ 646
2-Pipe ECO G GE3 Series	→ 647
3-Pipe ECO G GF3 Series	→ 648
3-Pipe Control Box Kit	→ 649
2-Pipe Hybrid EHP / GHP	→ 651
Water heat exchanger	→ 651
U2 type 4 way 90x90 cassette	→ 652
Y3 type 4 way 60x60 cassette	→ 653
L1 type 2 way cassette	→ 654
D1 type 1 way cassette	→ 654
F3 type variable static pressure adaptive duct	→ 655
M1 type slim variable static pressure hide-away concealed duct	→ 656
E2 type high static pressure hide-away	→ 656
T2 type ceiling	→ 657
K2 type wall-mounted	→ 658
G1 type floor console	→ 659
P1 type floor-standing	→ 659
R1 type concealed floor-standing	→ 660
Hydrokit for ECOi, water at 45 °C	→ 660
ERV with DX coil - HRPT Series	→ 661
Heat recovery with DX coil - ZDX Series	→ 662
Smart fan coils	→ 662

## Ventilation

AHU connection kit for PACi, ECOi and ECO G	→ 663
Advanced energy recovery ventilation - ZY Series	→ 663
Energy recovery ventilation - ZDY Series	→ 664
ERV with DX coil - HRPT Series	→ 665
Heat recovery with DX coil - ZDX Series	→ 666
Electric air curtain	→ 666
Air curtain with DX coil	→ 667
E2 type high static pressure hide-away	→ 667
Ceiling mounted air-e nanoe X Generator	→ 668
Heat recovery ventilation unit	→ 668
Counter flow ventilation	→ 669

## Connectivity

VRF Smart Connectivity+	→ 670
Commercial Wi-Fi Adaptor	→ 672
Design wired remote controller	→ 672
Econavi sensor	→ 672
Remote sensor	→ 672
CONEX wired remote controller	→ 672
Intelligent controller (touch screen/web server)	→ 672
Infrared remote controller	→ 672
System controller with weekly timer	→ 673
Mini Seri-Para I/O Unit 0 -10 V	→ 673
Central ON / OFF controller	→ 673
Local adaptor for ON / OFF control	→ 673
Communication adaptor	→ 673

## Refrigeration

CR Series 4,0 kW	→ 674
CR Series 7,5 and 8,0 kW	→ 674
CR Series 15,0 and 16,0 kW	→ 675
CR Series 29,0 kW	→ 675

Aquarea All in One H Series.

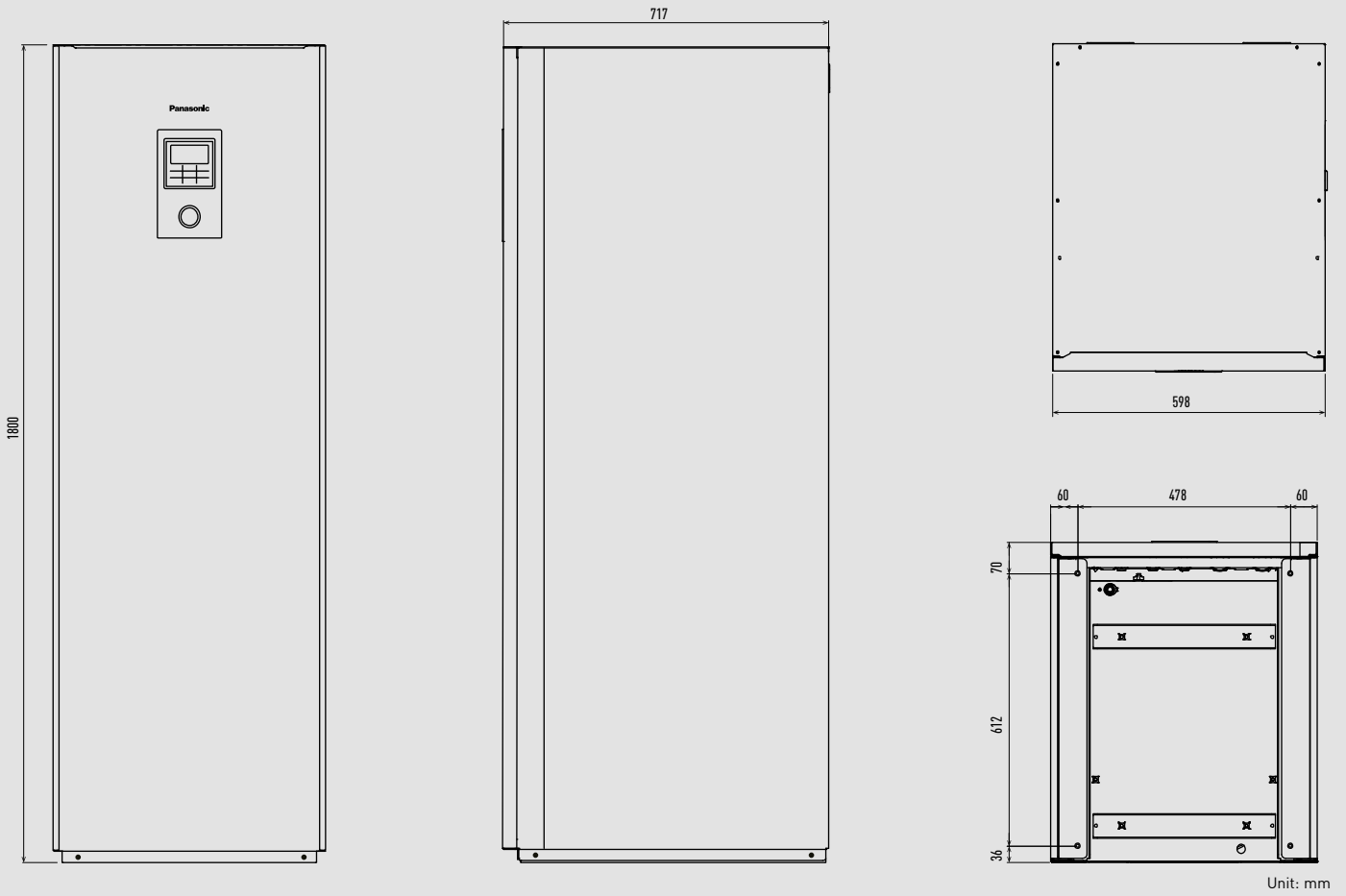

Aquarea All in One J Series.

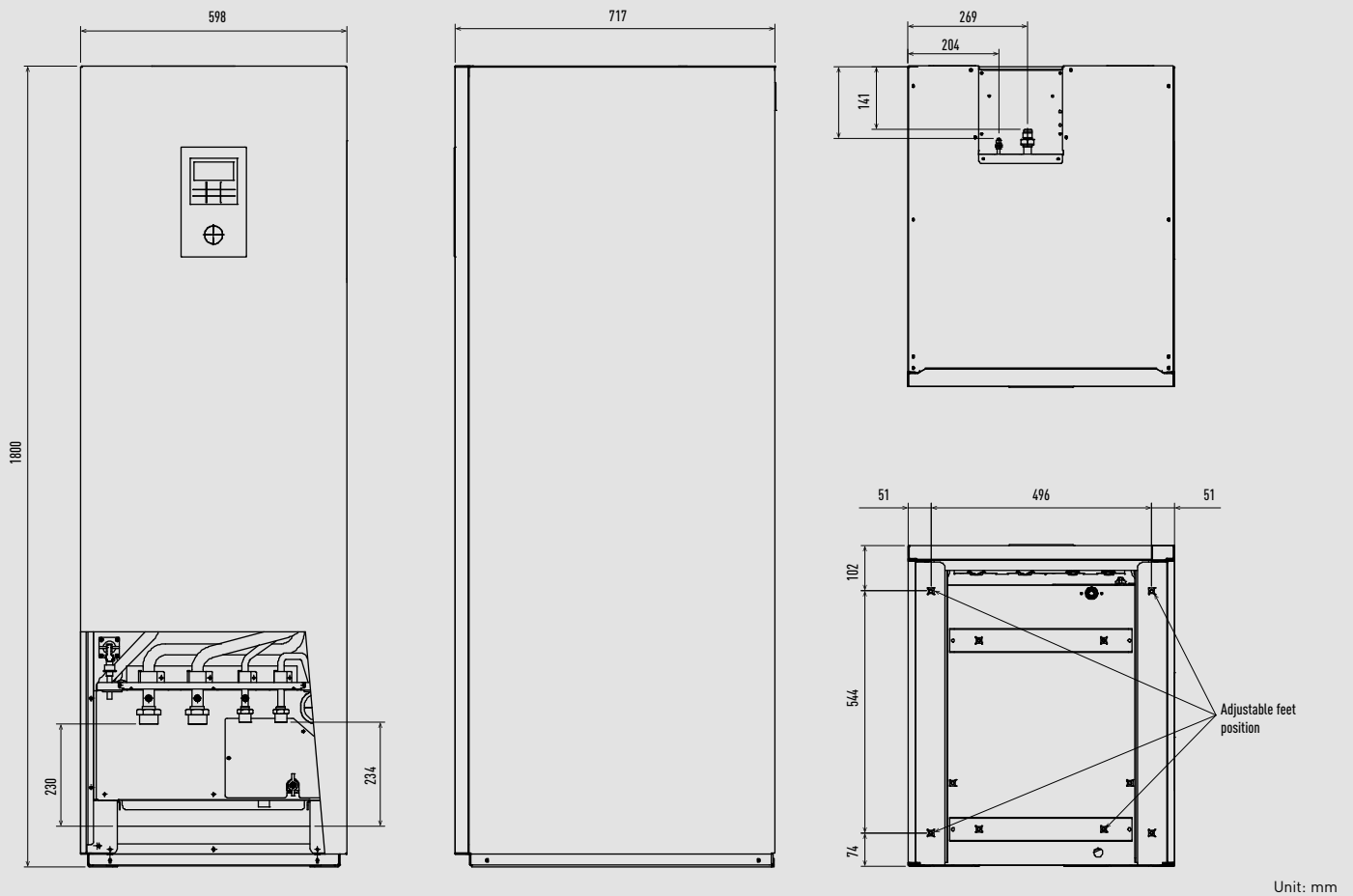

Aquarea All in One K Series.

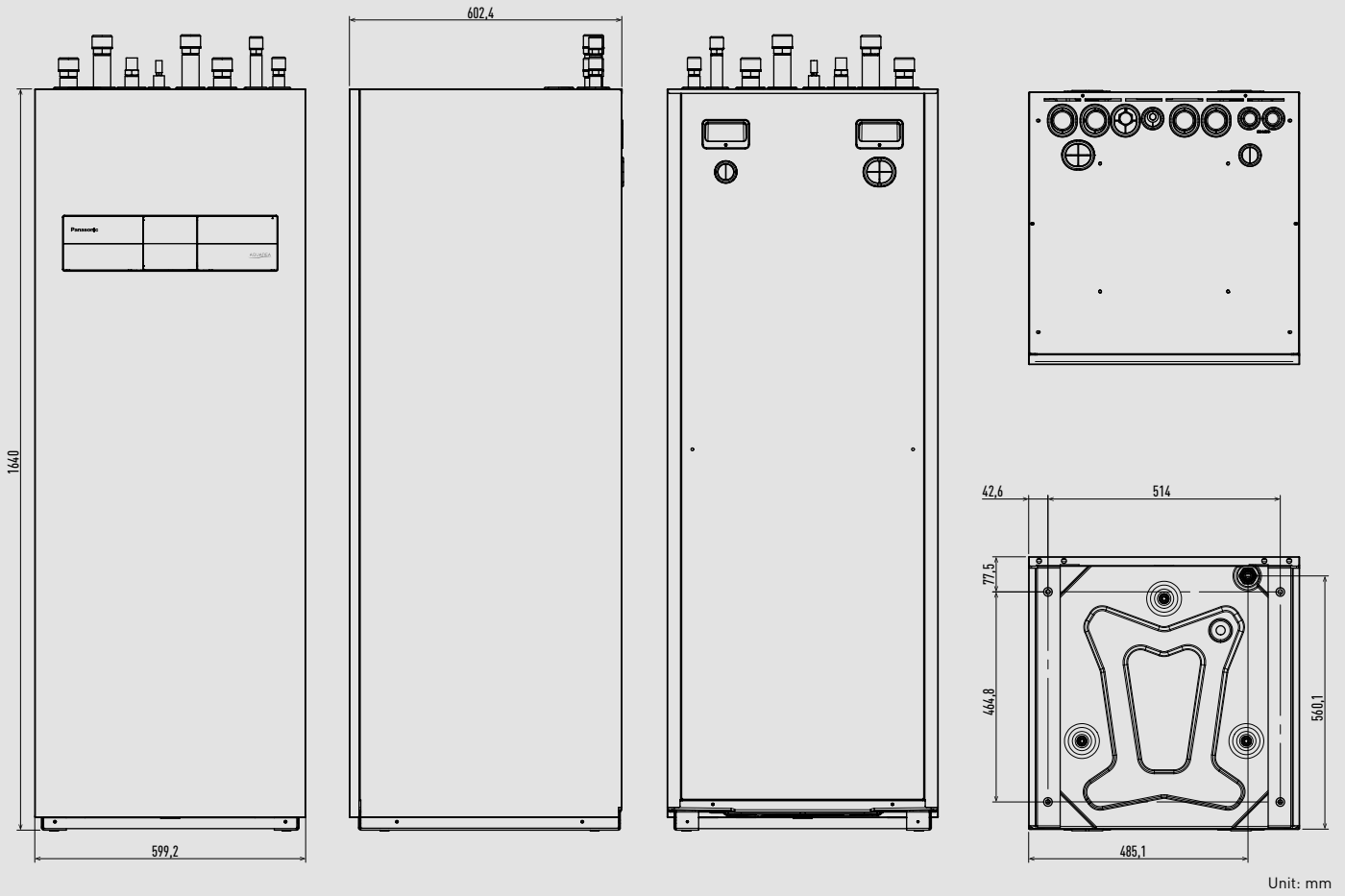

Aquarea High Performance hydraulic All in One / with Electrical Anode L Series.

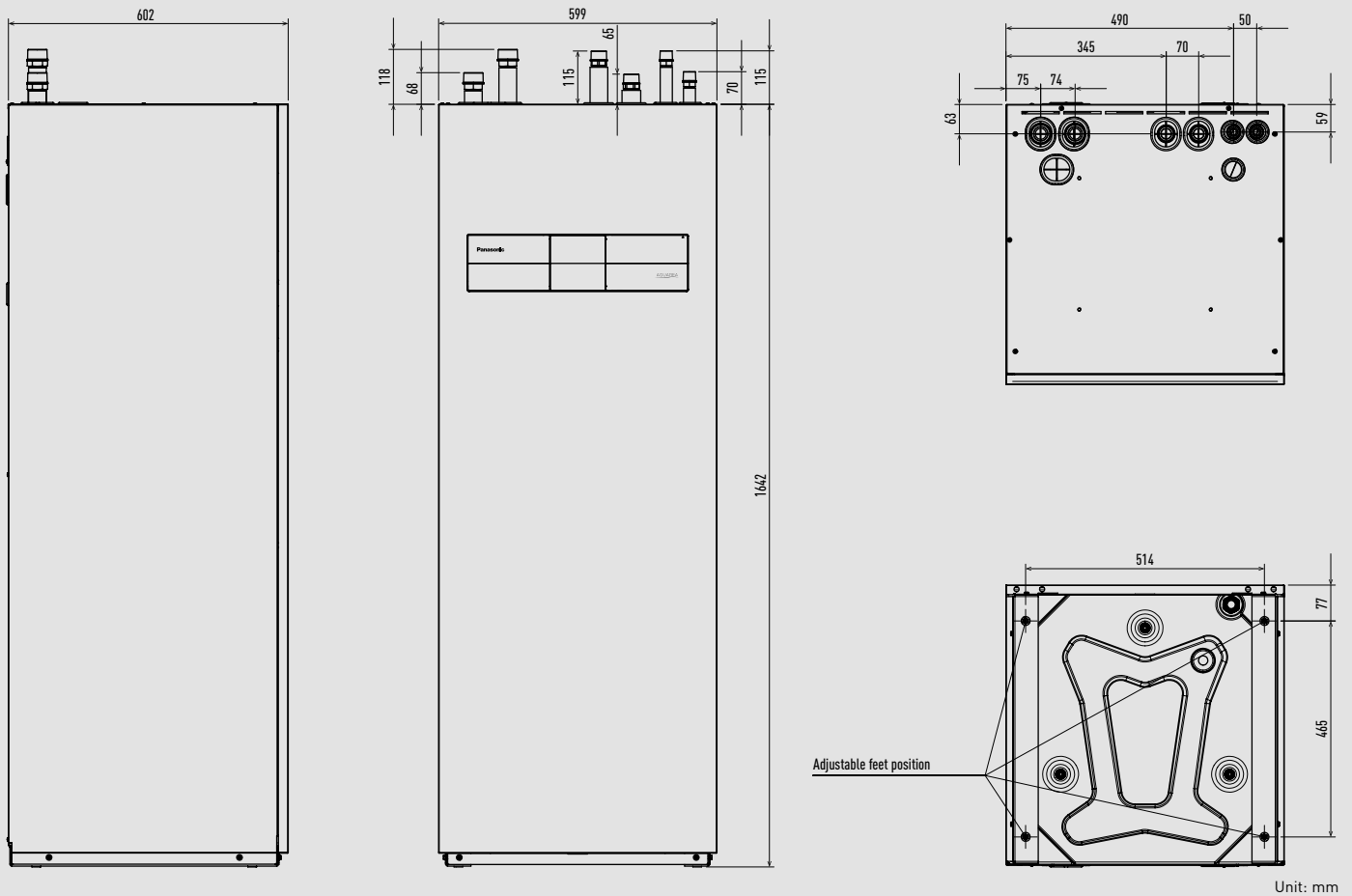



Aquarea High Performance hydraulic All in One 2 zones L Series.

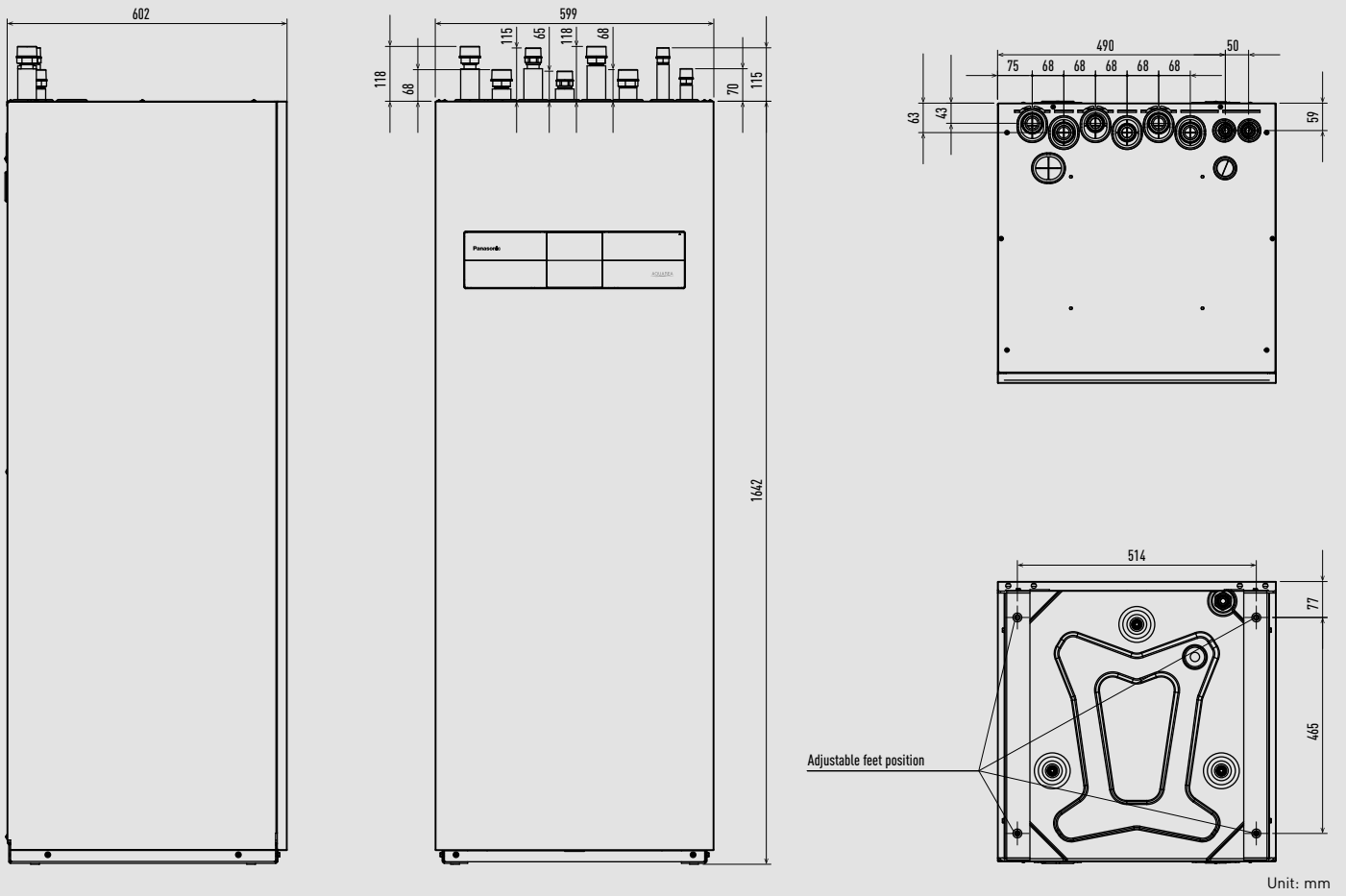

Aquarea All in One M Series (185 L).

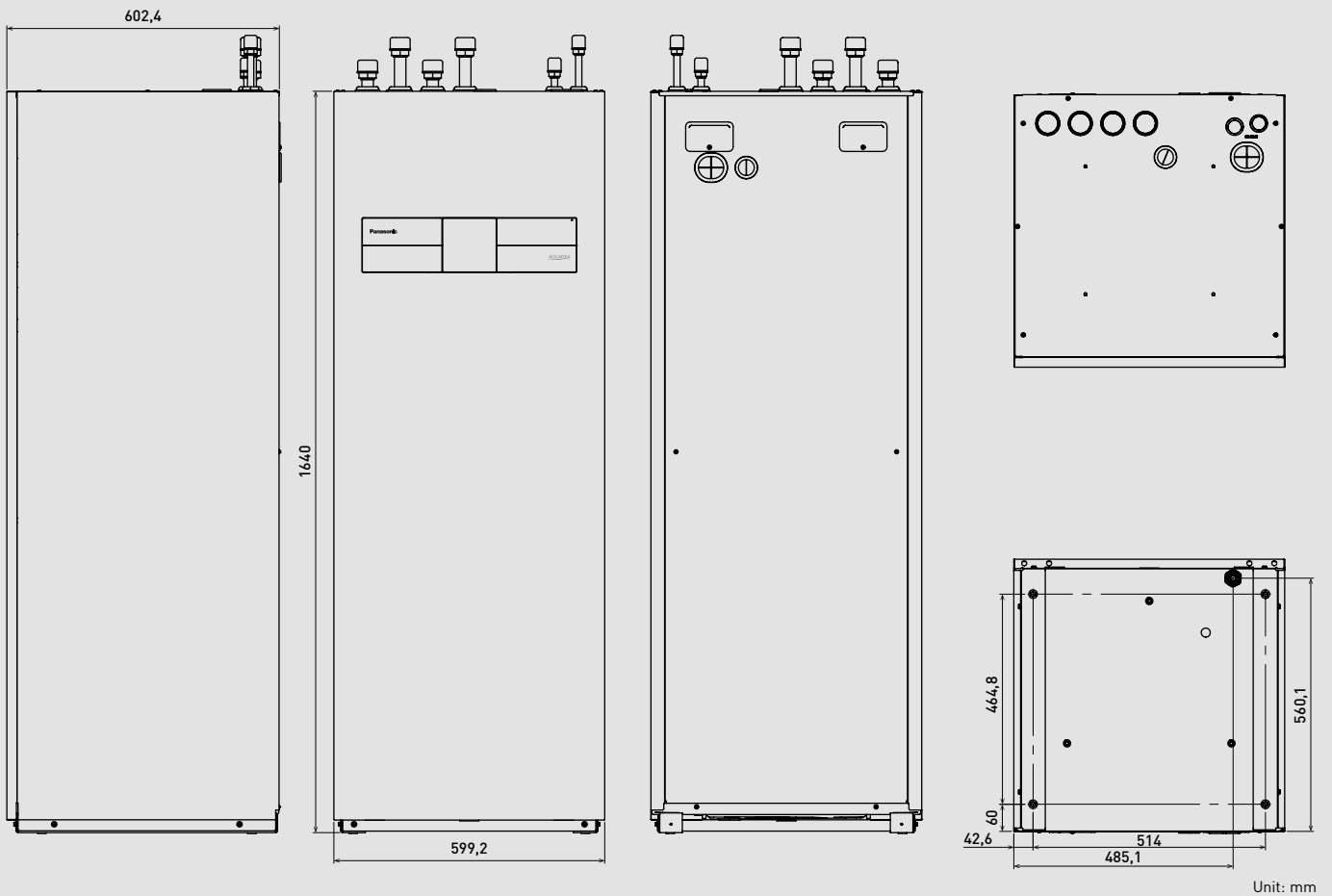

Aquarea All in One M Series (260 L).

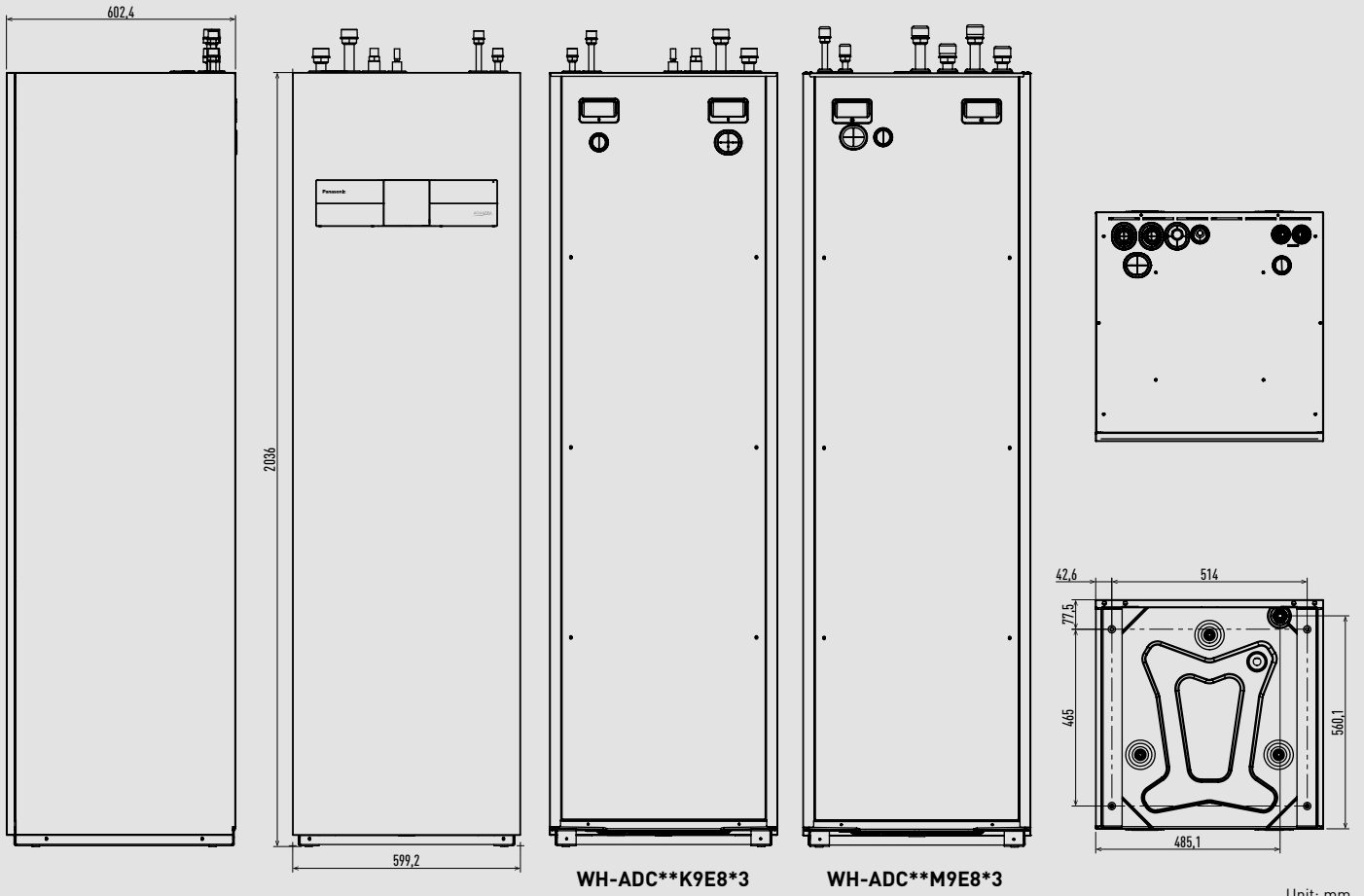

Aquarea hydraulic module H and J Series.

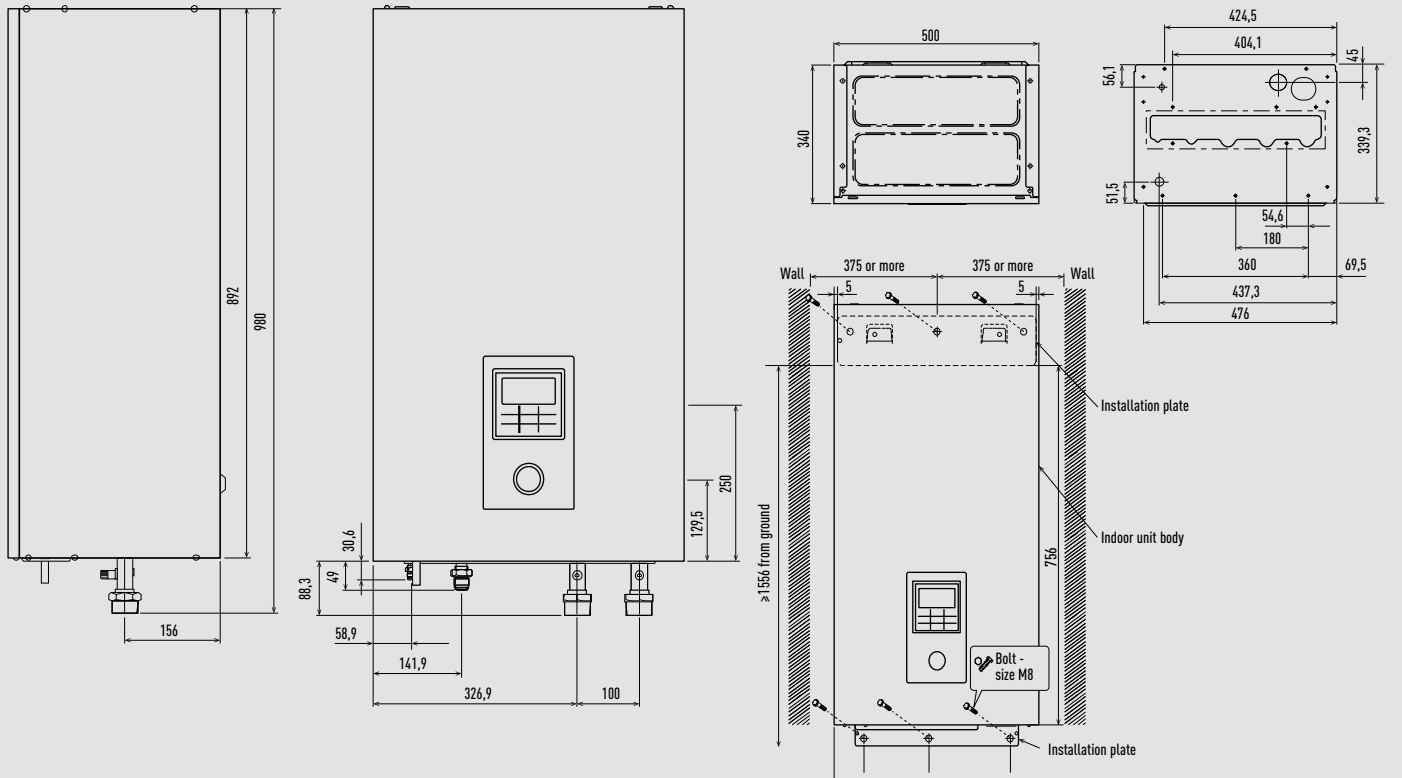

Aquarea hydraulic module K Series.

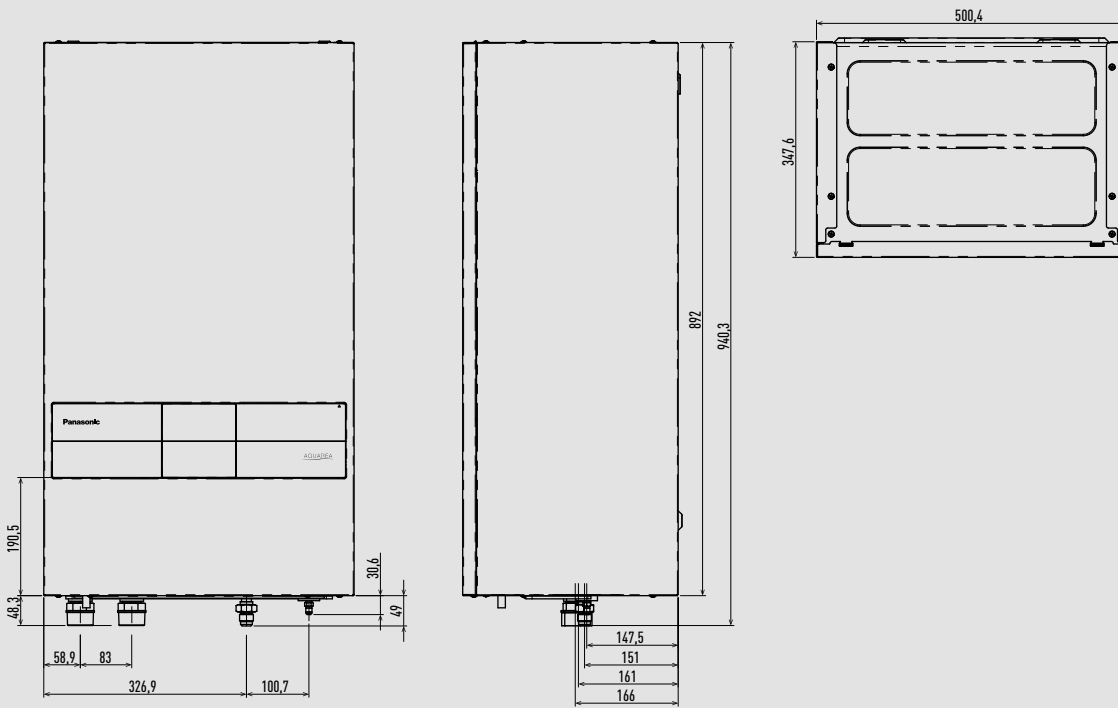

Unit: mm

Aquarea Hydraulic Bi-bloc L Series.

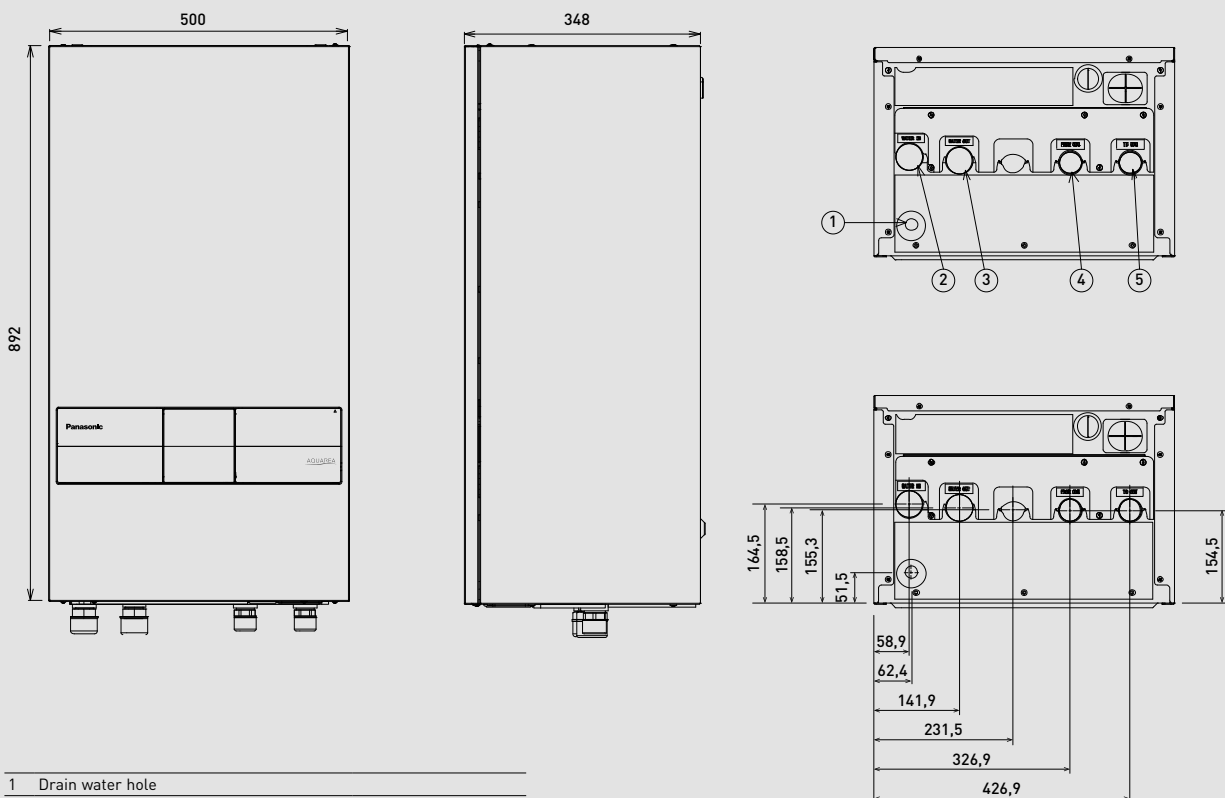

1	Drain water hole	
2	Water inlet	R 1 1/4"
3	Water outlet	R 1 1/4"
4	Water inlet (from outdoor unit)	R 1"
5	Water outlet (to outdoor unit)	R 1"

Unit: mm

Aquarea Hydraulic Bi-bloc M Series.

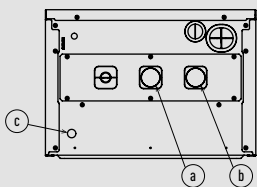
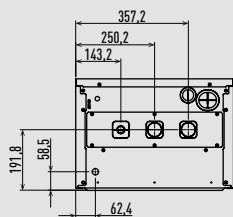
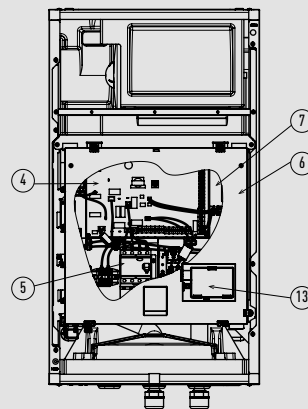
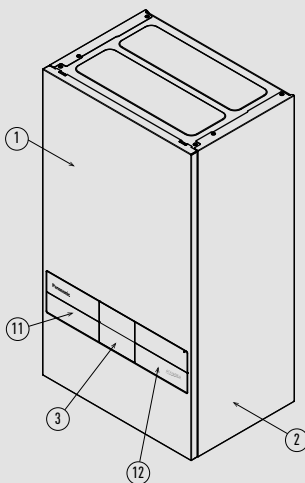
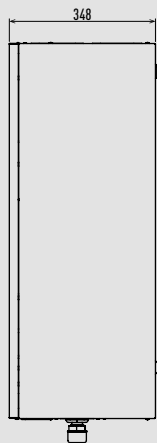
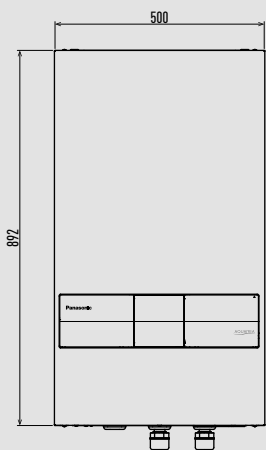

a	Water inlet	R 1 1/4
b	Water outlet	R 1 1/4
c	Drain water hole	

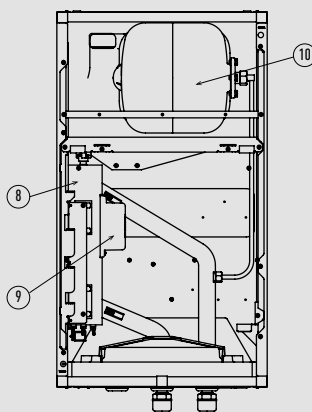

- 1 Cabinet front plate
- 2 Cabinet side plate
- 3 Remote controller
- 4 PCB
- 5 Three phase RCCB/ELCB
- 6 Control board cover
- 7 Control board
- 8 Backup heater
- 9 Overload protector
- 10 Expansion vessel
- 11 Left decoration panel
- 12 Right decoration panel
- 13 Network adaptor holder

Unit: mm

Aquarea EcoFlex tank unit.

Front view

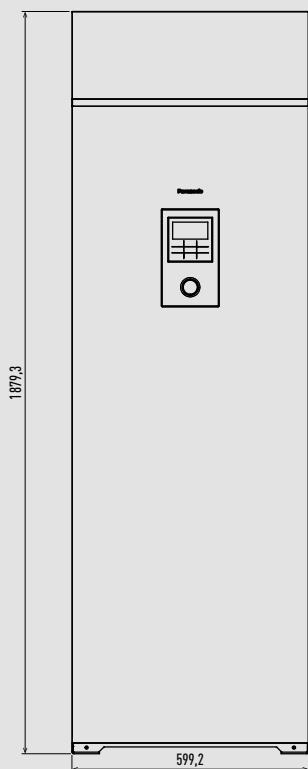

Side view

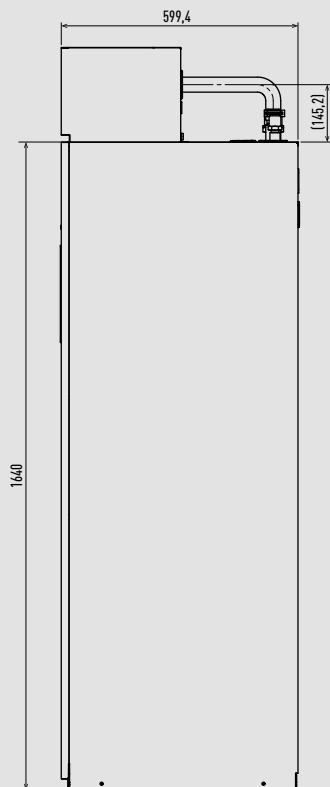

Rear view

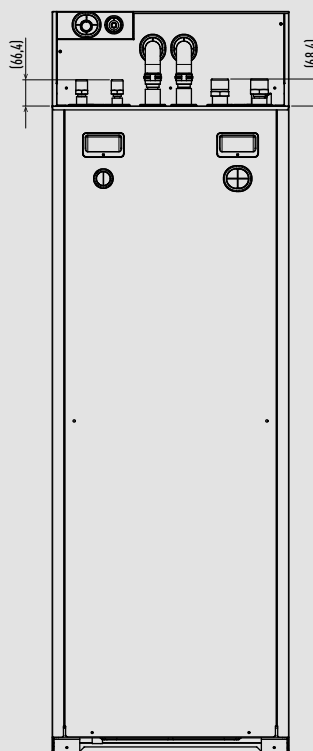

Bottom view

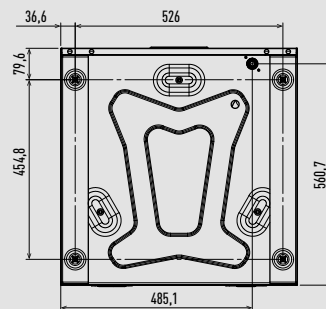

Top view

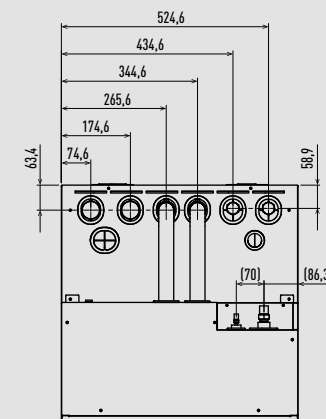

Unit: mm

Aquarea EcoFlex ducted unit.

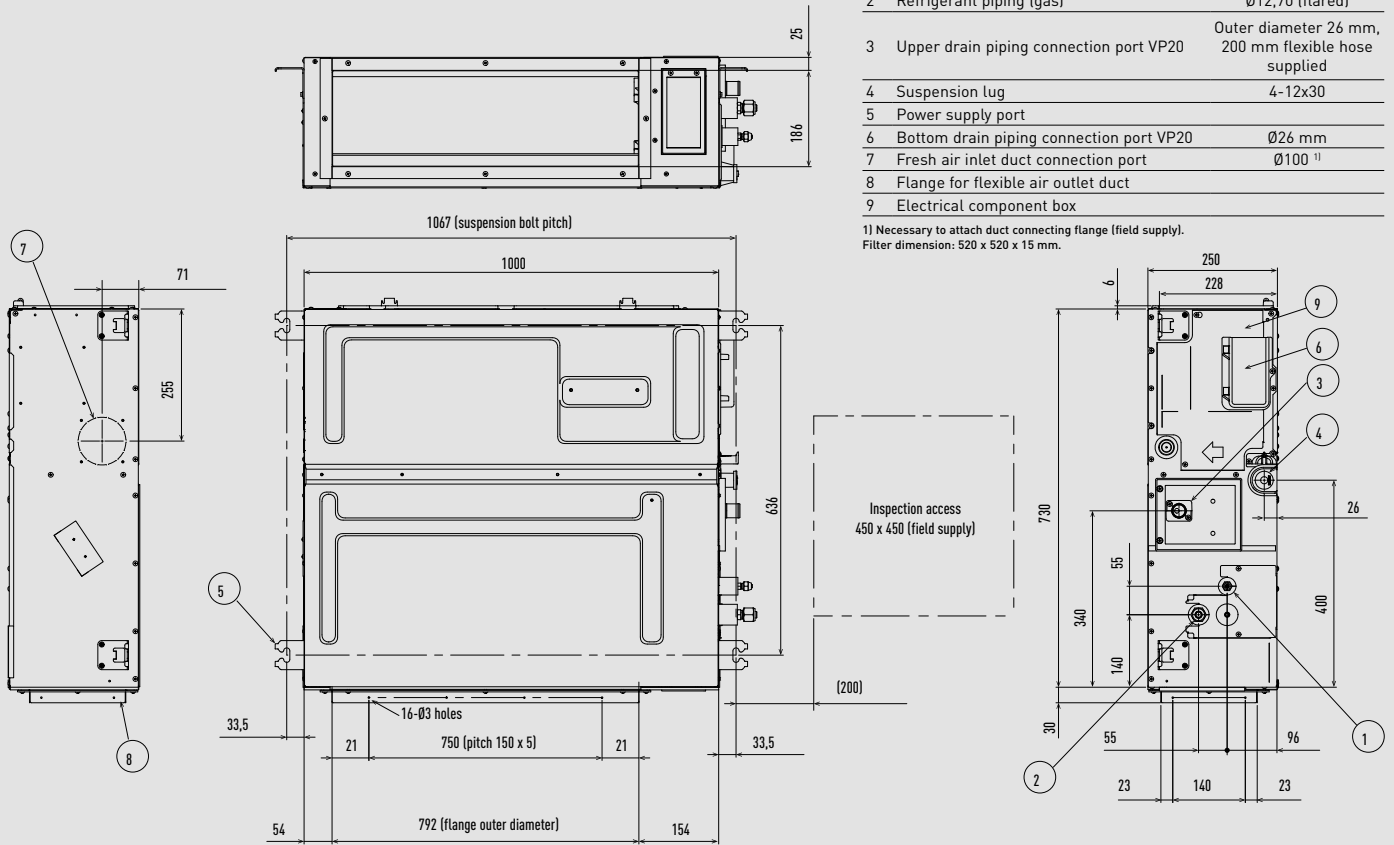

Unit: mm

Aquarea EcoFlex outdoor unit.

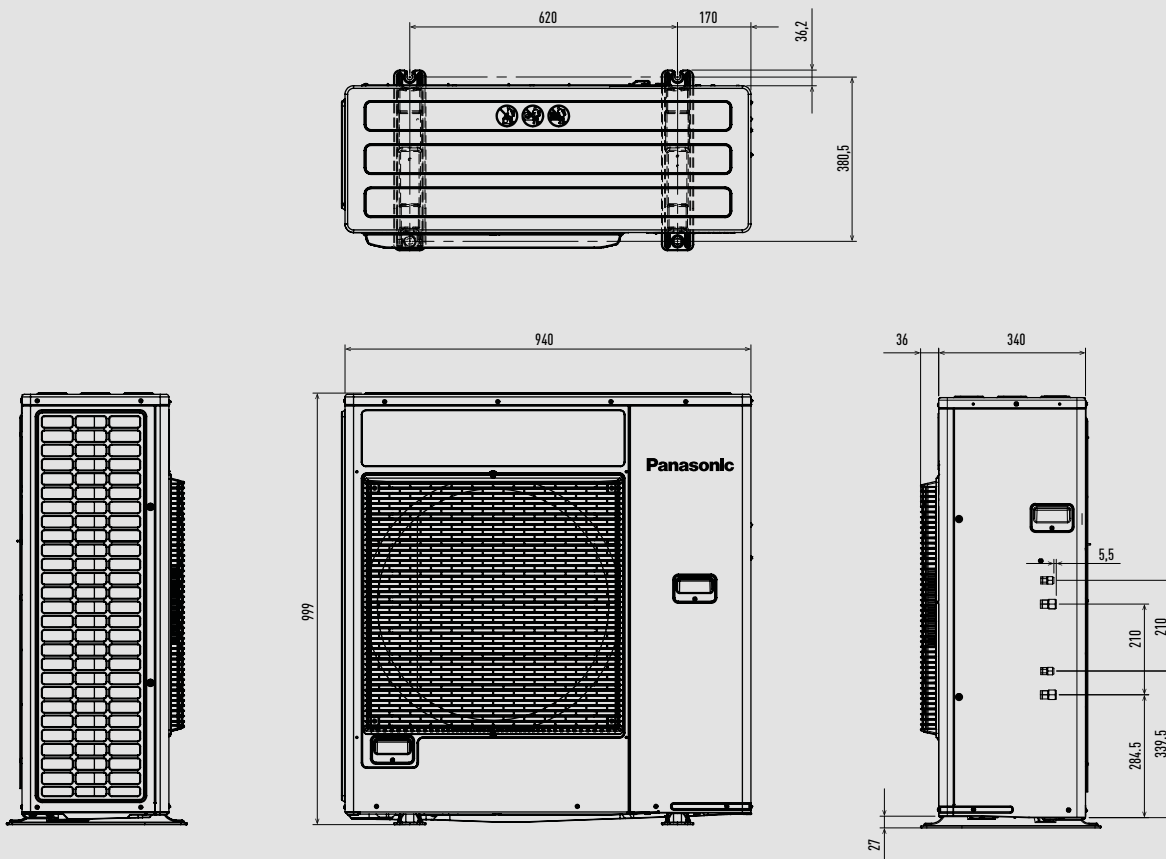

Unit: mm

Aquarea High Performance Bi-bloc outdoor unit 3 kW K Series, 3 and 5 kW H and J Series.

Space necessary for installation

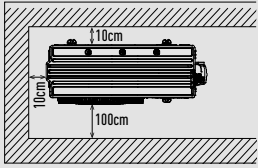

Anchor bolt pitch 355 x 260

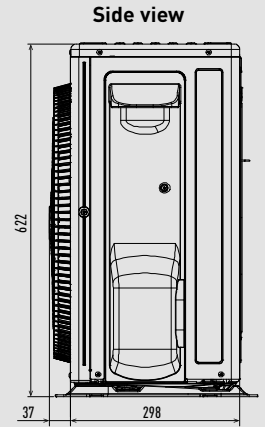
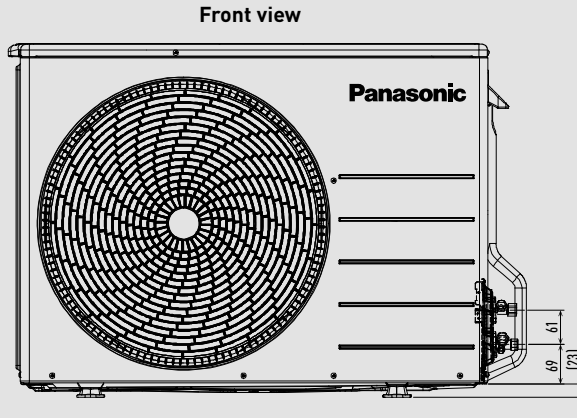
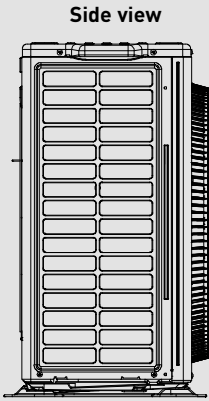
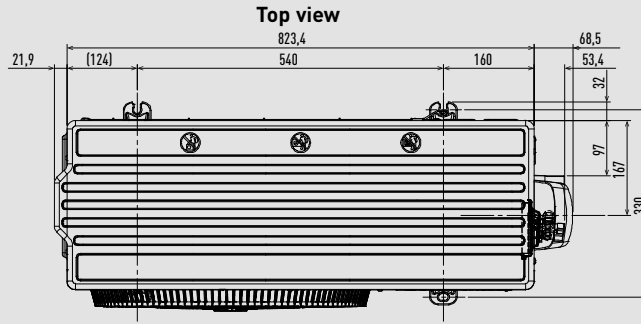

Unit: mm

Aquarea High Performance Bi-bloc outdoor units from 5 to 9 kW K Series.

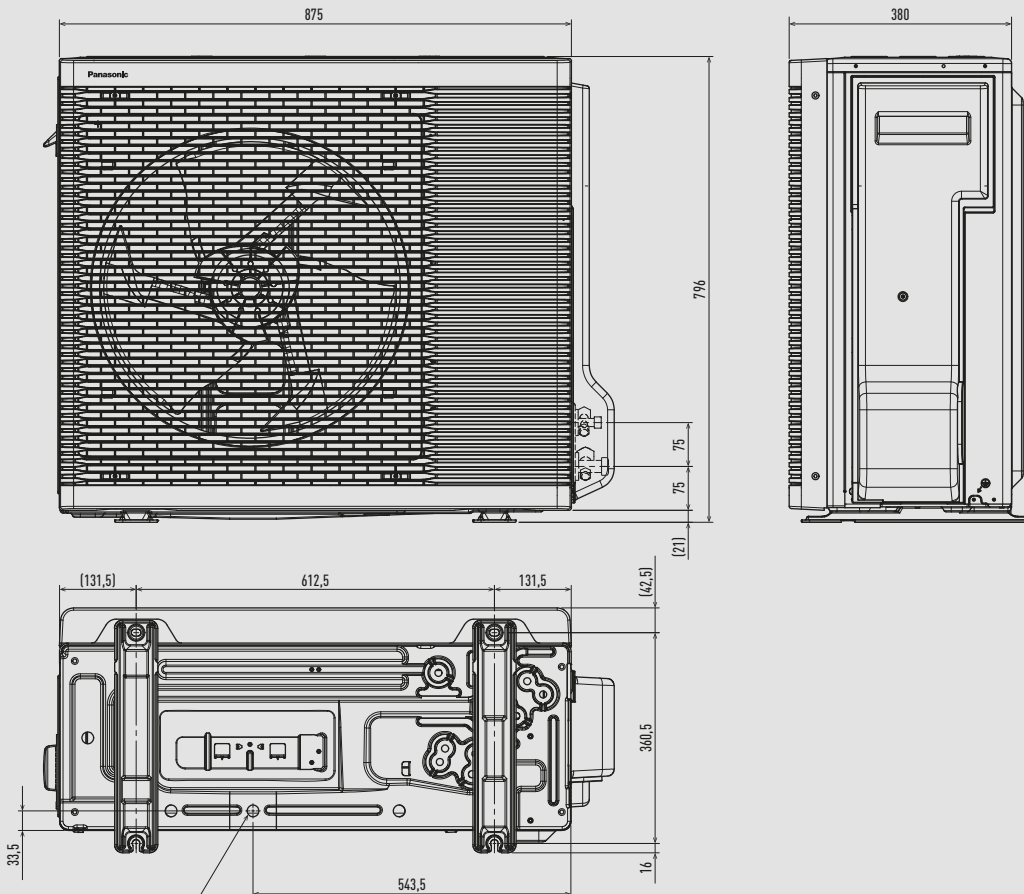

Unit: mm



Aquarea High Performance, T-CAP Bi-bloc outdoor units from 9 to 16 kW.

[Except High Performance 9 kW single phase].

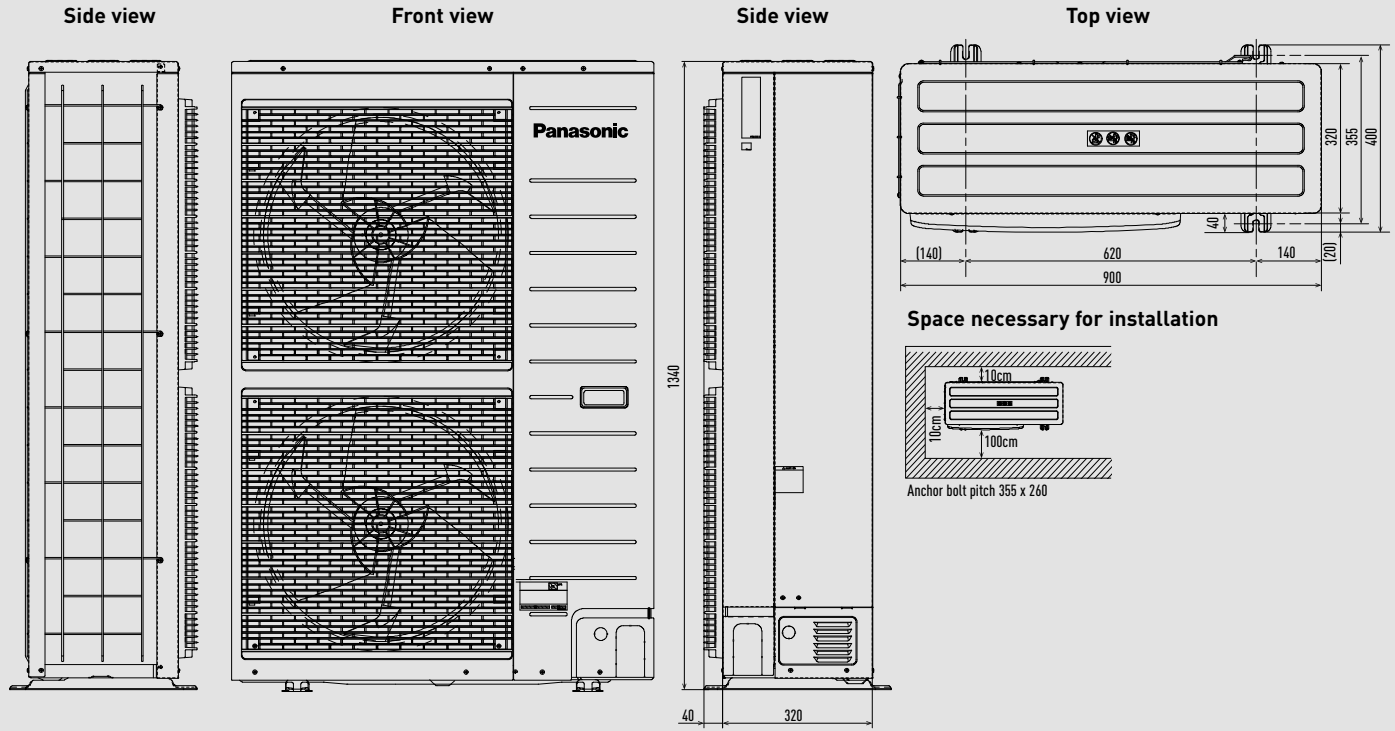

Unit: mm

Aquarea T-CAP Hydraulic M Series outdoor units from 9 to 16 kW.

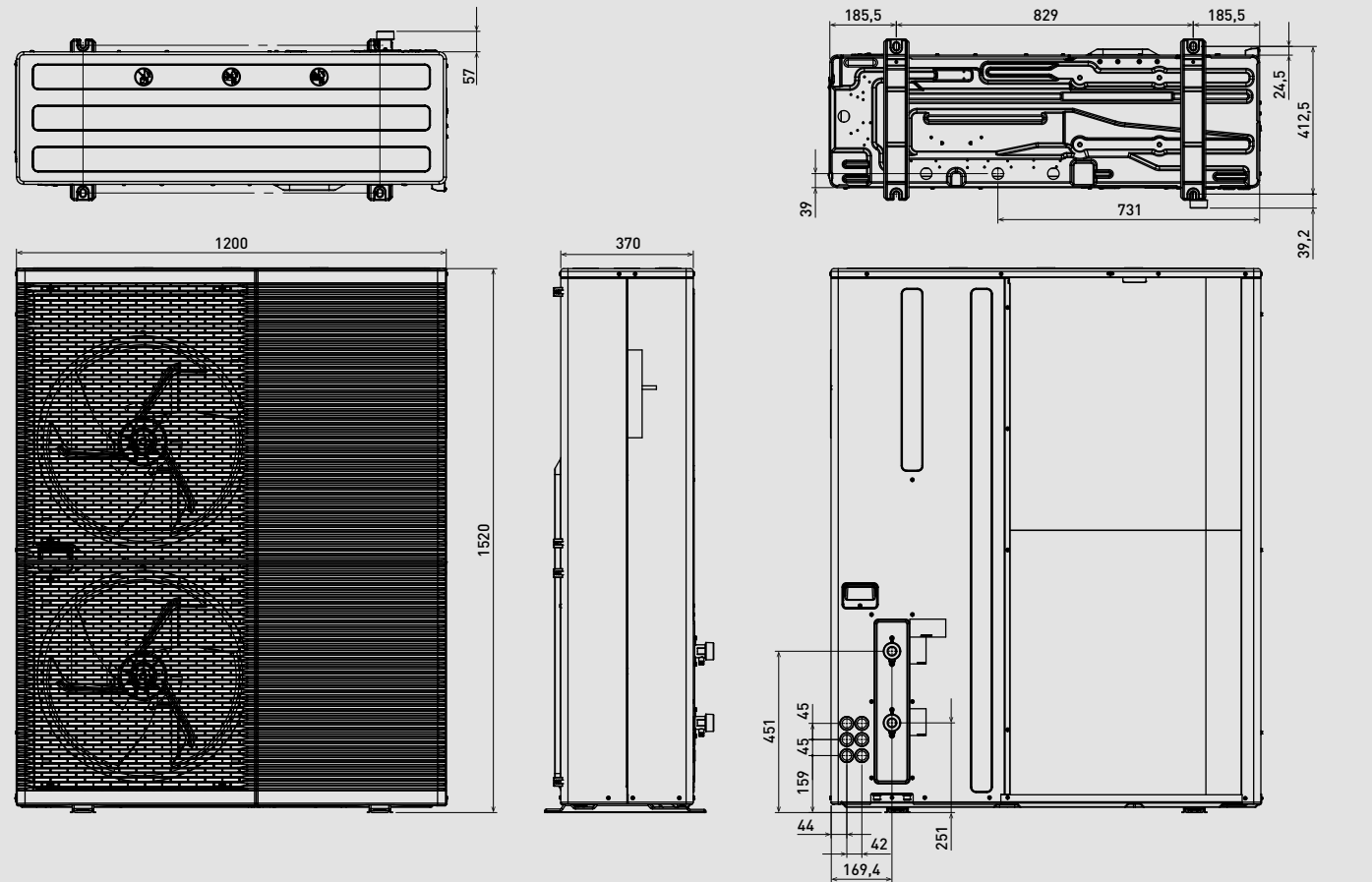

Unit: mm

Aquarea High Performance Mono-bloc outdoor units from 5 to 9 kW.

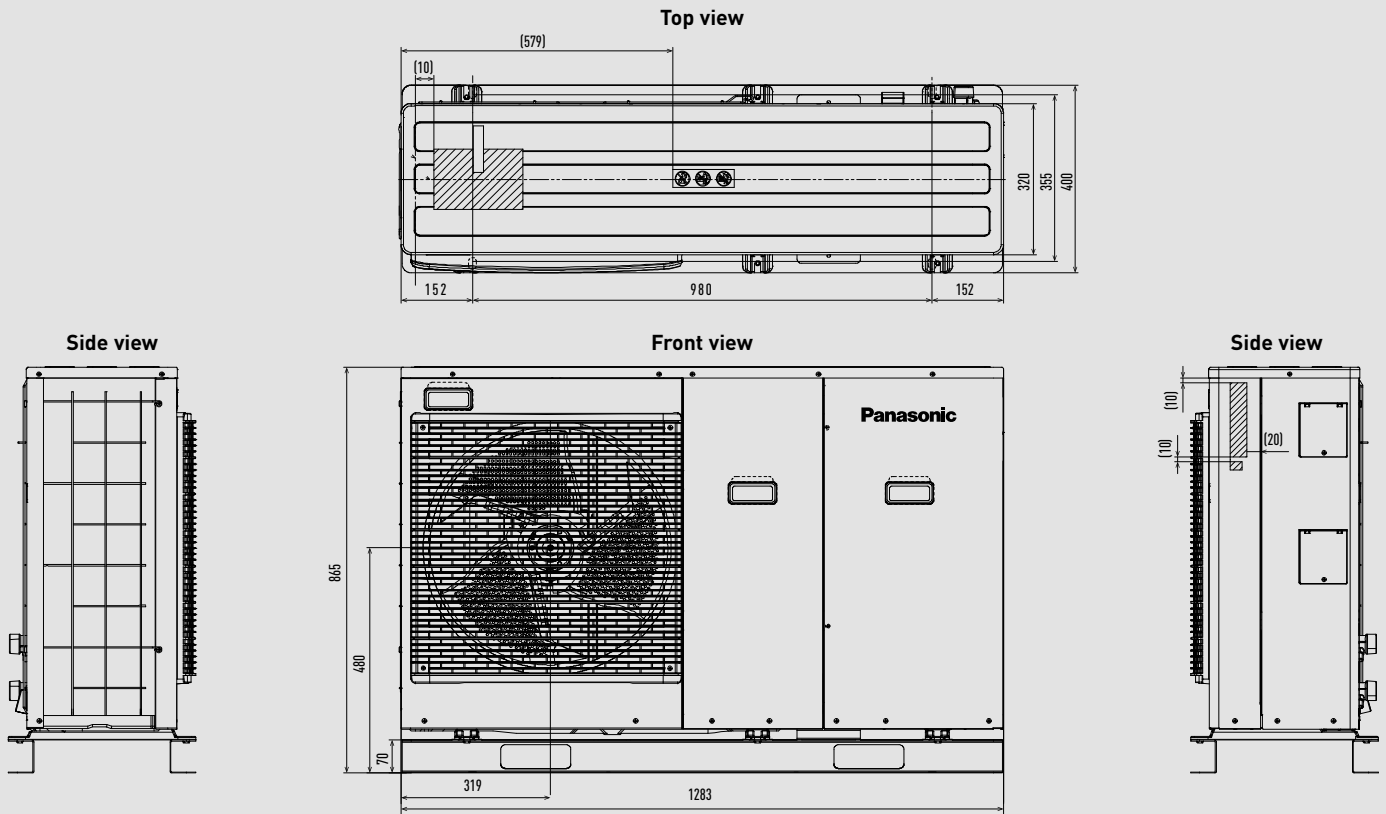

Unit: mm

Aquarea High Performance, T-CAP Mono-bloc outdoor unit and T-CAP Bi-bloc Super Quiet outdoor units from 9 to 16 kW.

(Except High Performance 9 kW).

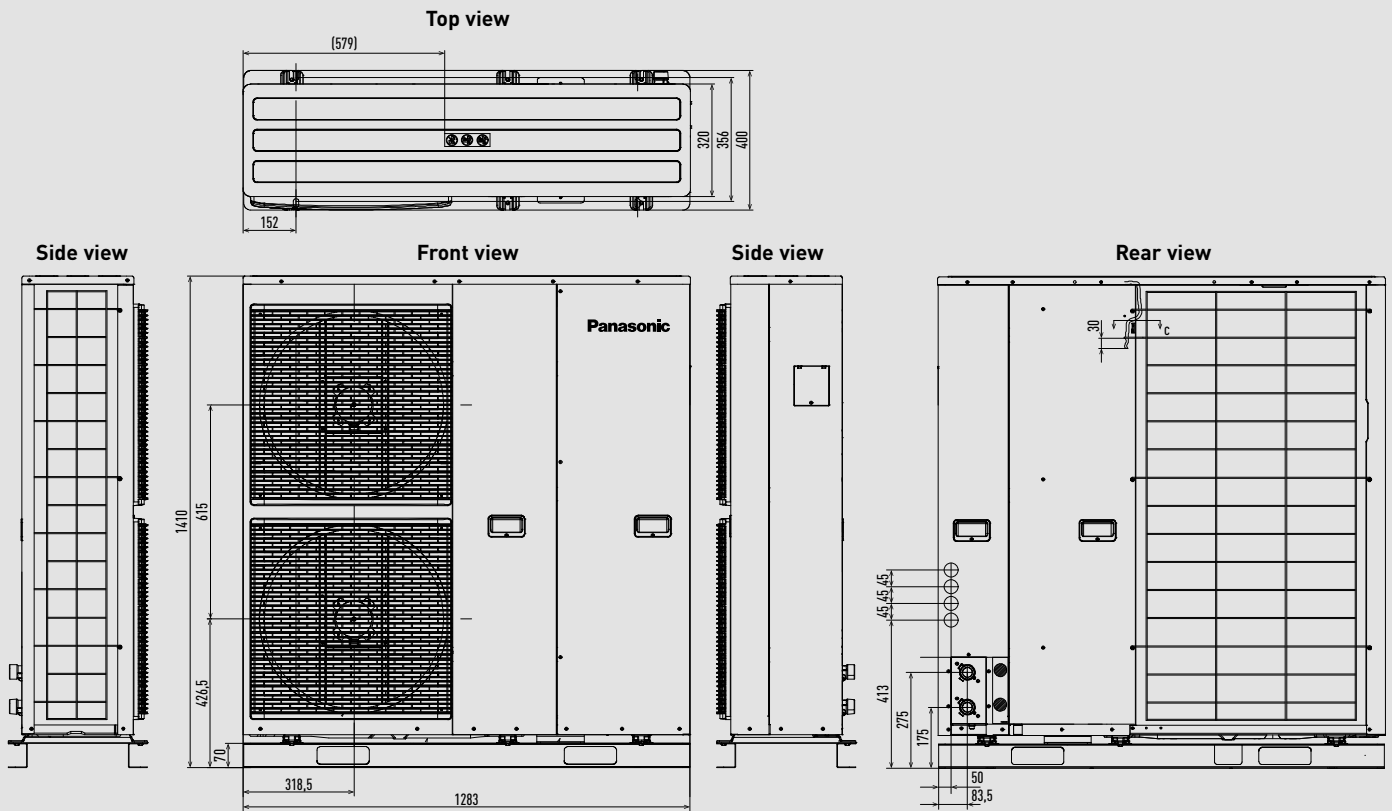

Unit: mm

Aquarea T-CAP Bi-bloc outdoor units from 9 to 12 kW K Series.

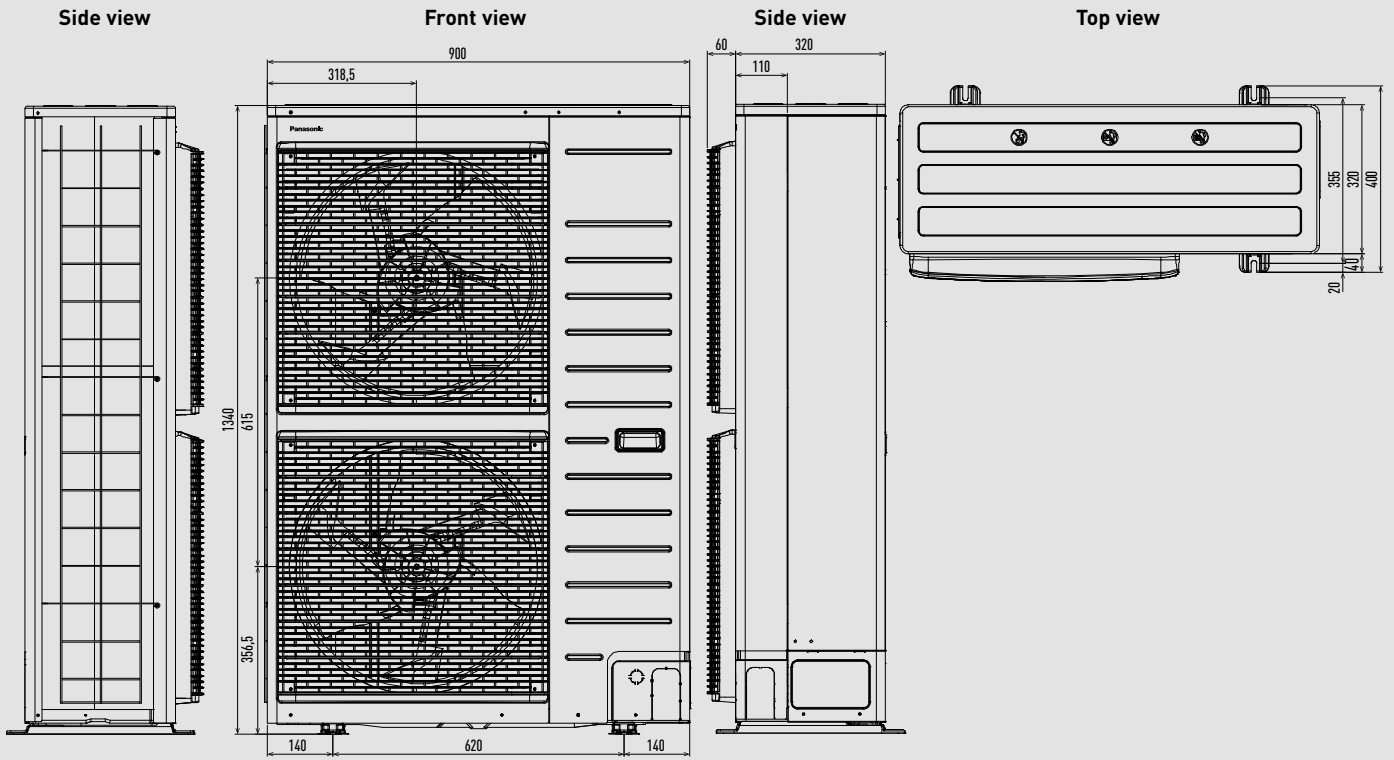

Unit: mm

Smart fan coils.

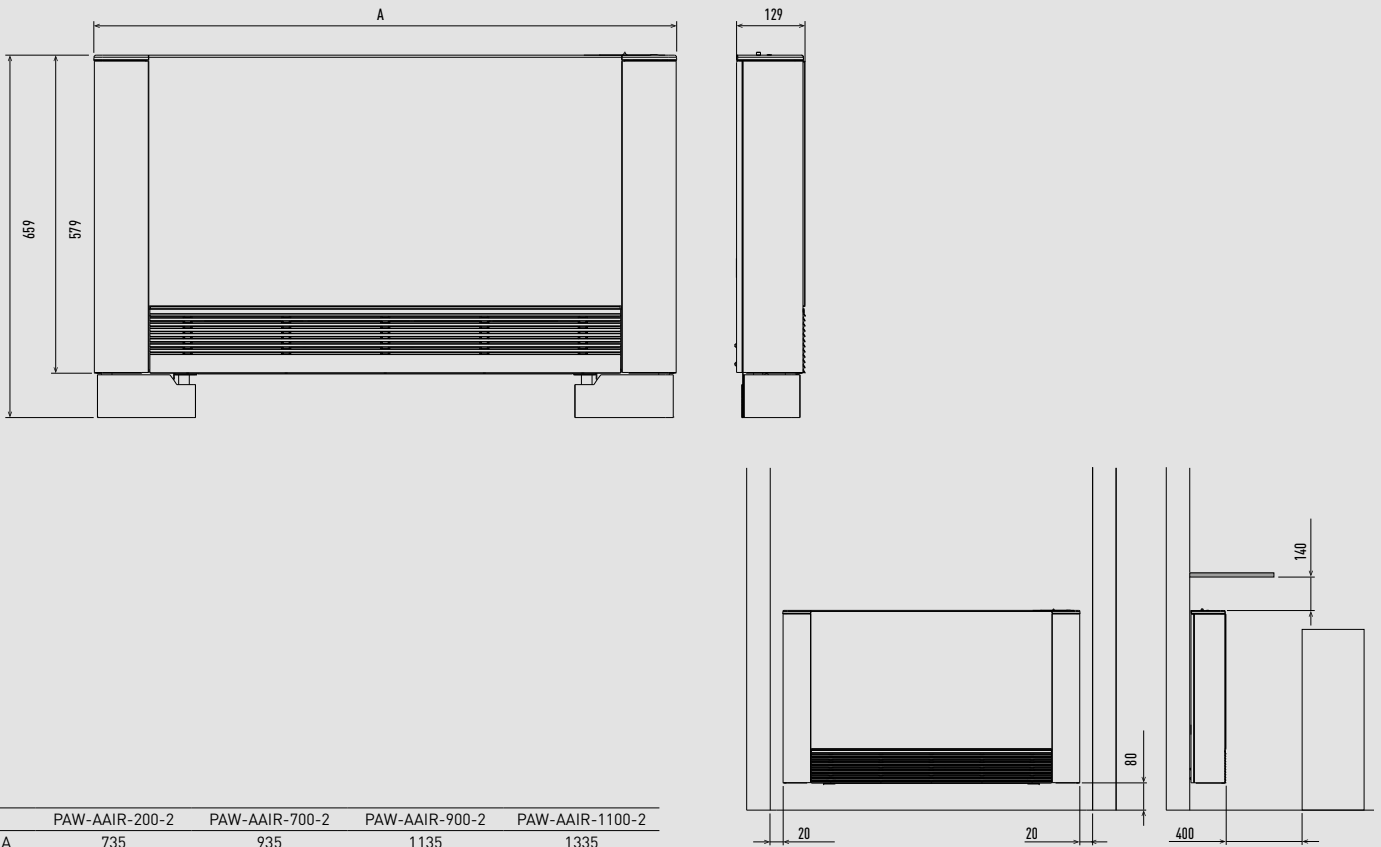

Unit: mm

Buffer tank - PAW-BTANK50L-2 / PAW-BTANK100L.

	A*	B*	C	D	E	Ø
PAW-BTANK50L-2	704	636	422	192	96	435
PAW-BTANK100L	1243	1175	962	192	96	435

Tolerance +/- 5 mm. \* Total height tolerance +0 / -13 mm.

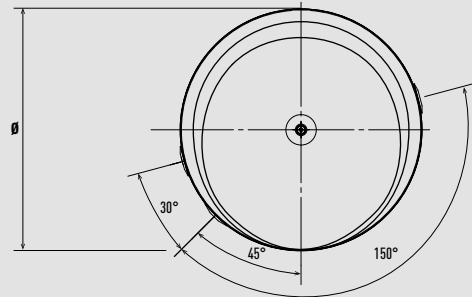
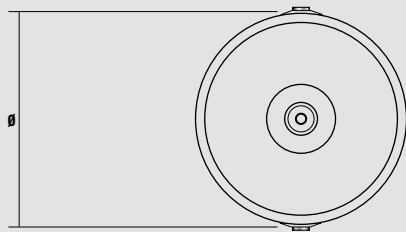
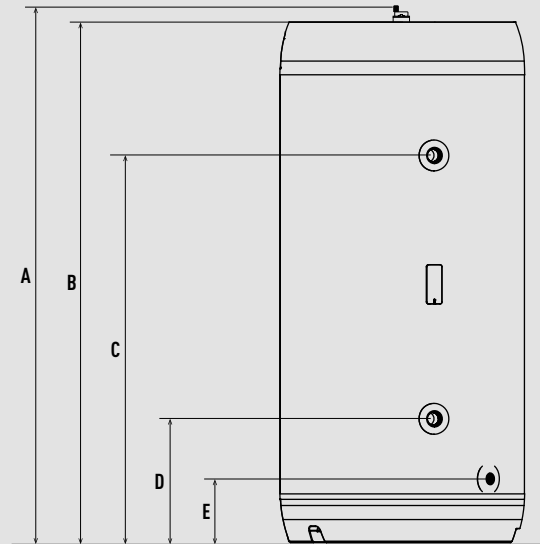
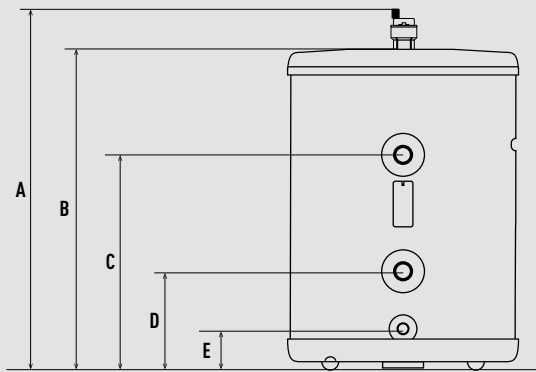

Unit: mm

Buffer tank - PAW-BTANKG200L / PAW-BTANKG260L.

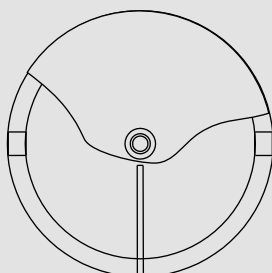
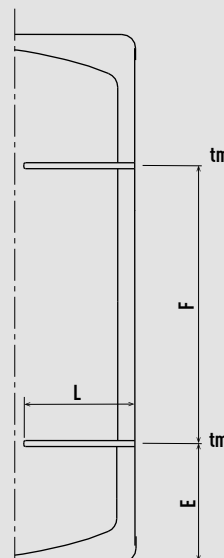
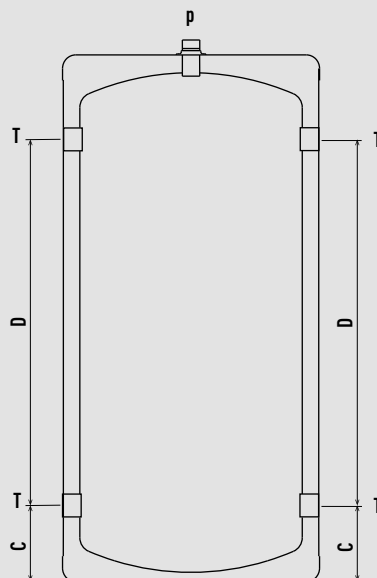
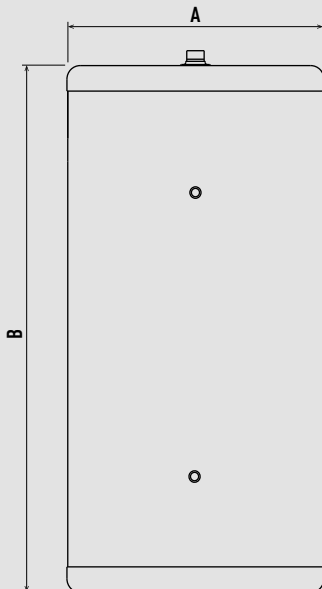

	A: External diameter	B: Overall height	C	D	E	F	L	T: connection	tm: probe tube for sensors	p: Purge
	mm	mm	mm	mm	mm	mm	mm	Inch G/F	Ø int. (mm)	Inch G/M
PAW-BTANKG200L	620	983	168	624	194	566	285	1 1/2	10	1
PAW-BTANKG260L	620	1293	168	873	279	652	285	1 1/2	10	1

Unit: mm

Enamelled tank - PAW-TA15C1E5.

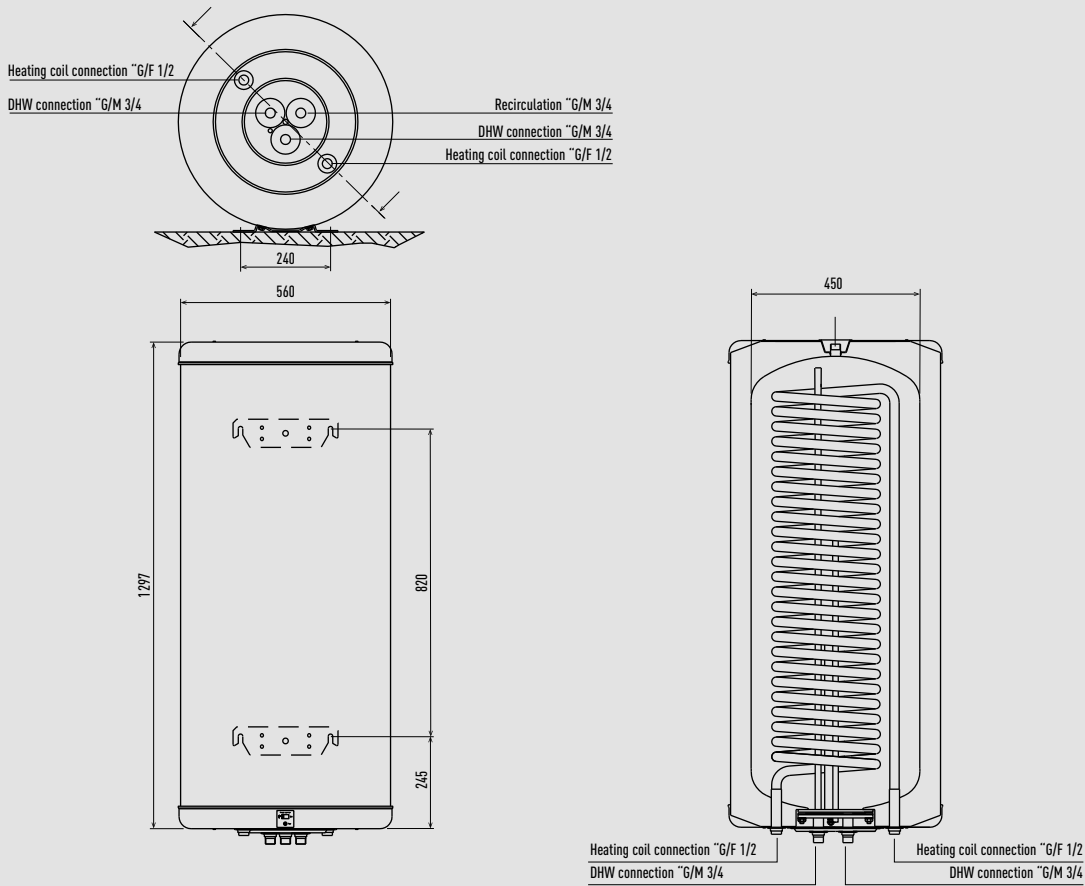

Unit: mm

Enamelled tanks - PAW-TA20C1E5STD / PAW-TA30C1E5STD / PAW-TA40C1E5STD.

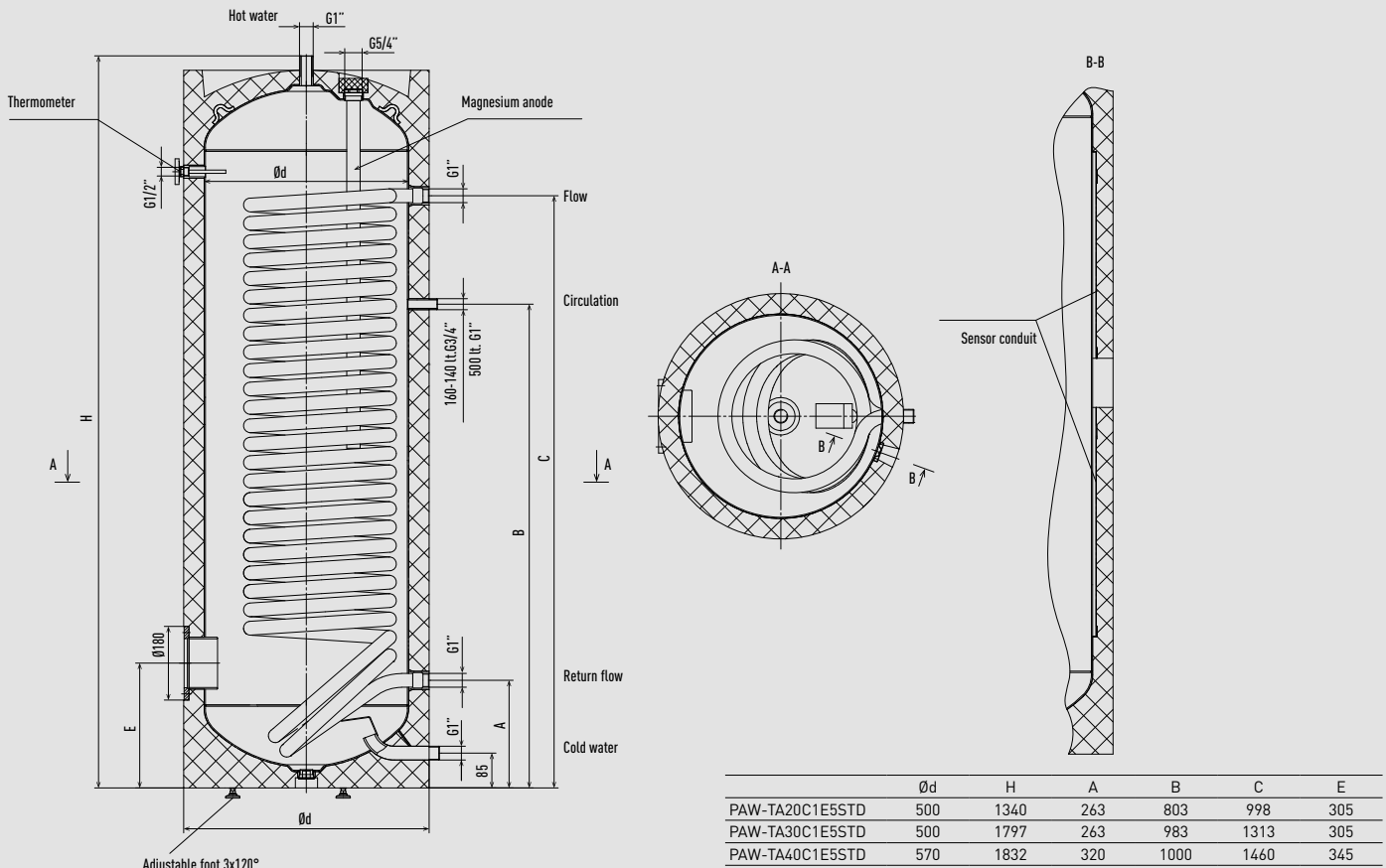

Unit: mm





Counter flow ventilation - PAW-VENTX20H-1 / PAW-VENTX30H-1 / PAW-VENTX40H-1.

PAW-VENTX20H

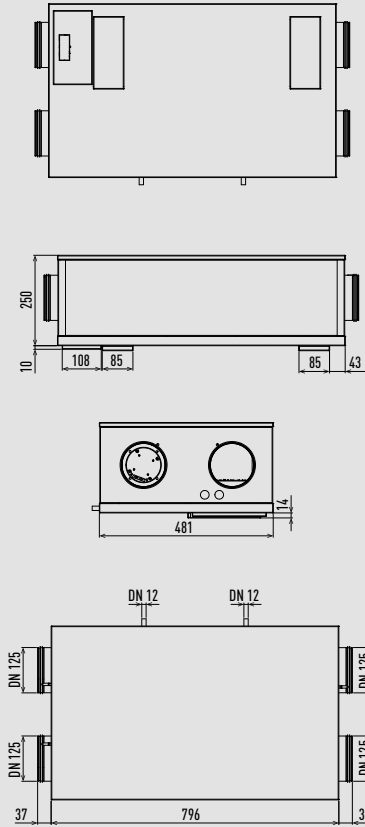

PAW-VENTX30H

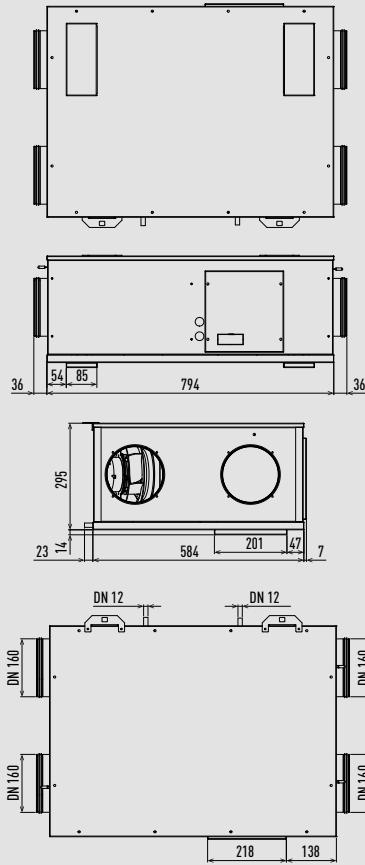

PAW-VENTX40H

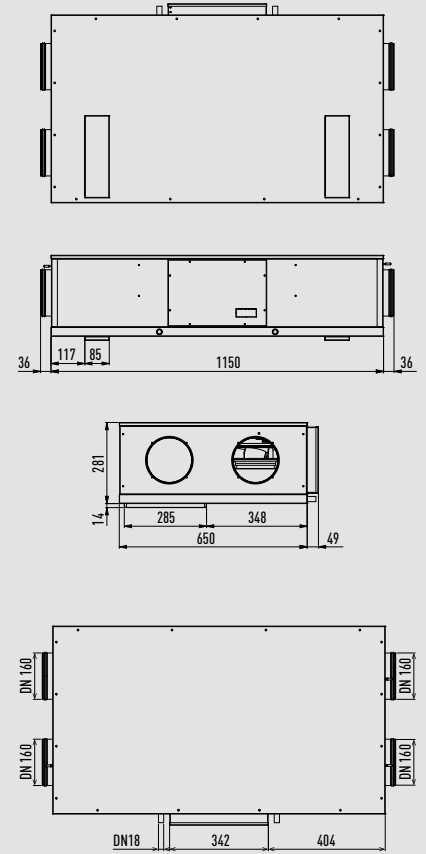

Unit: mm

Counter flow ventilation - PAW-VENTX20V-1 / PAW-VENTX30V-1 / PAW-VENTX40V-1.

PAW-VENTX20V

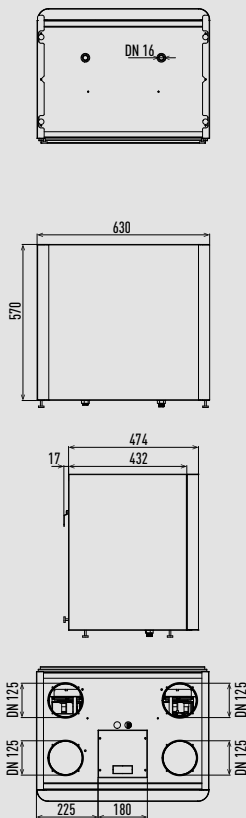

PAW-VENTX30V

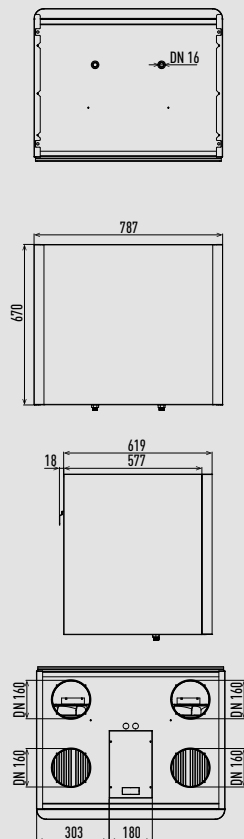

PAW-VENTX40V

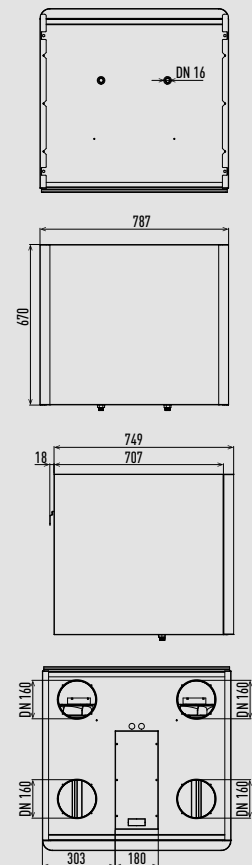

Unit: mm

DHW Stand Alone.

Wall-mounted

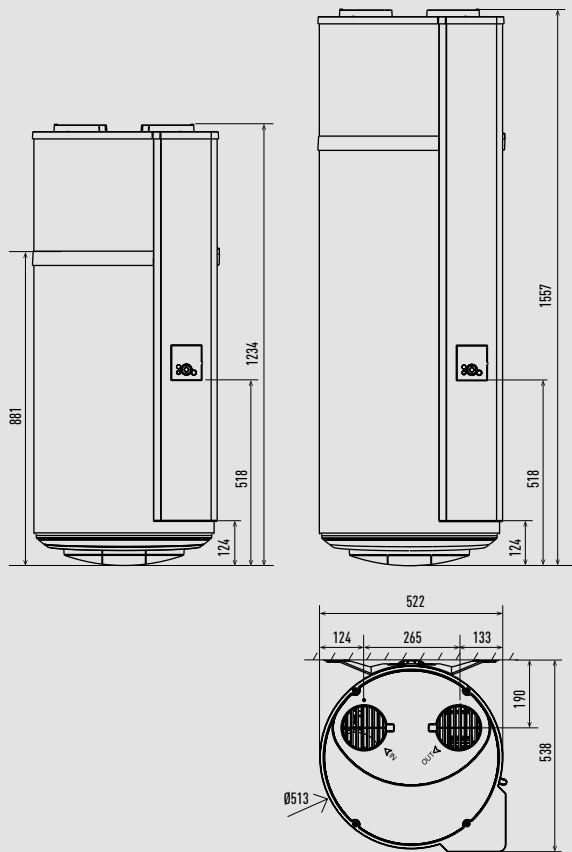

Floor-standing

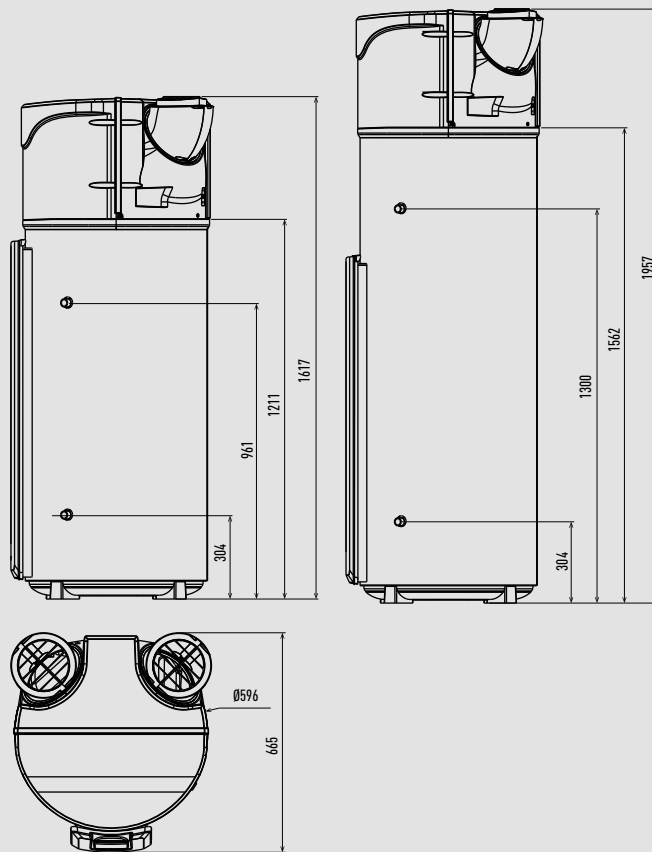

Unit: mm

Wall-mounted Heatcharge VZ.

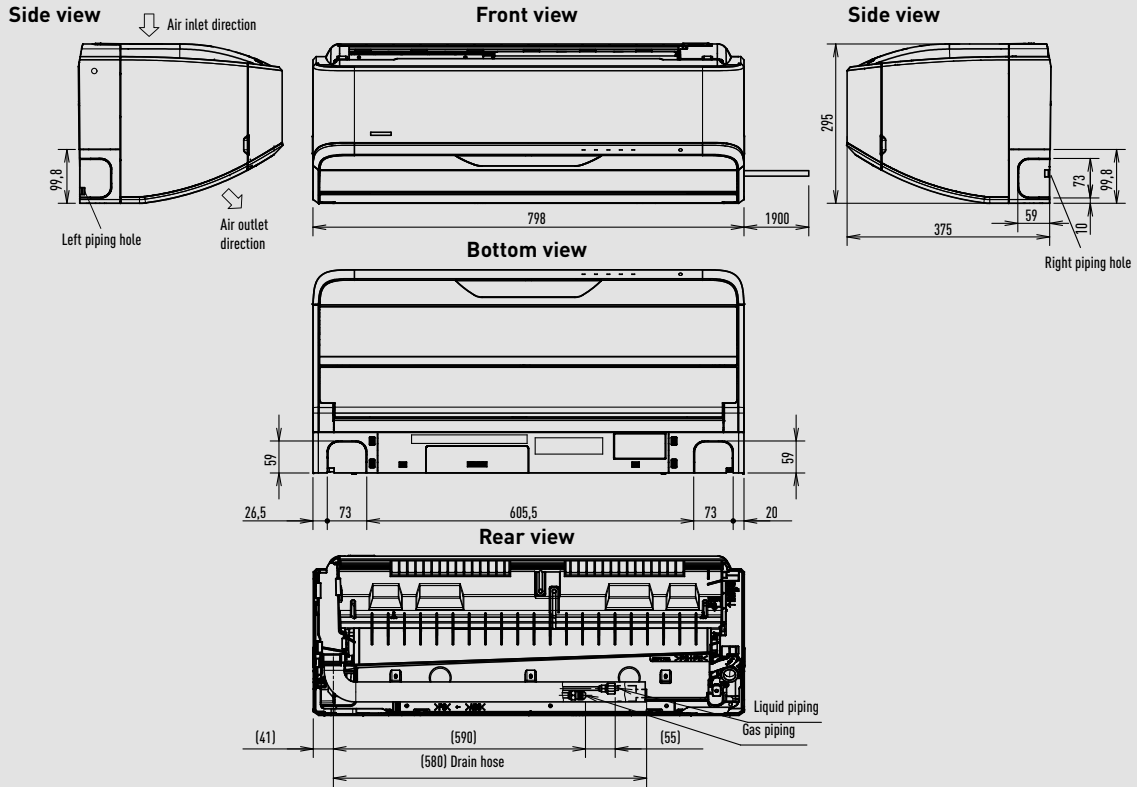

Relative position between the indoor unit and the installation plate

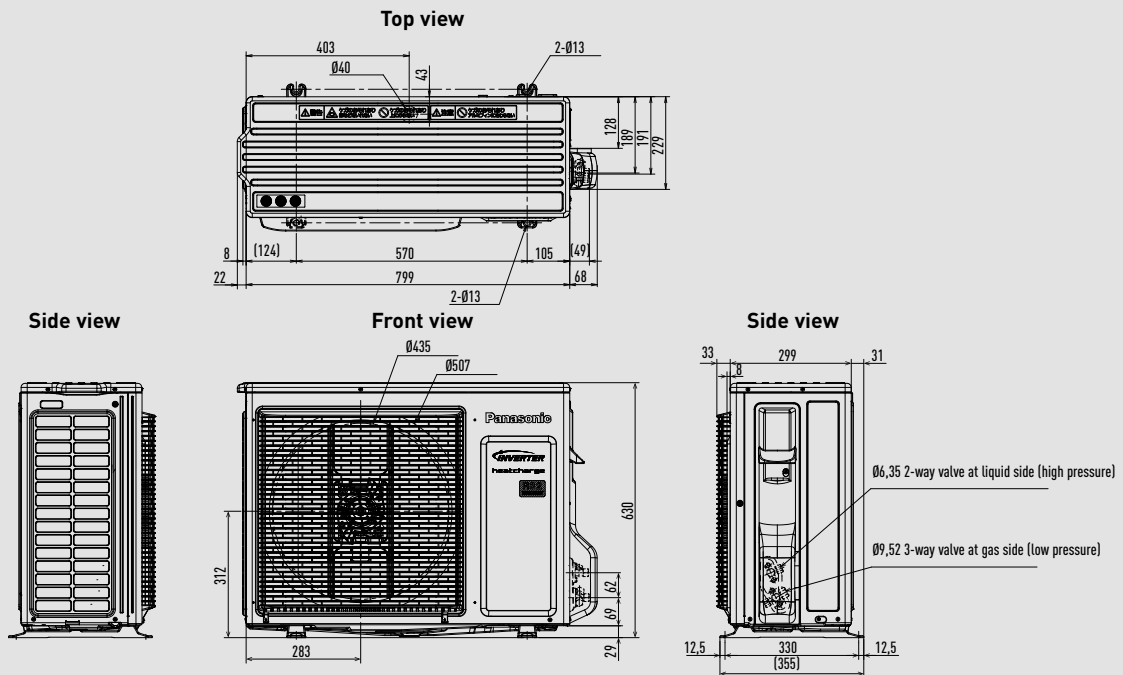
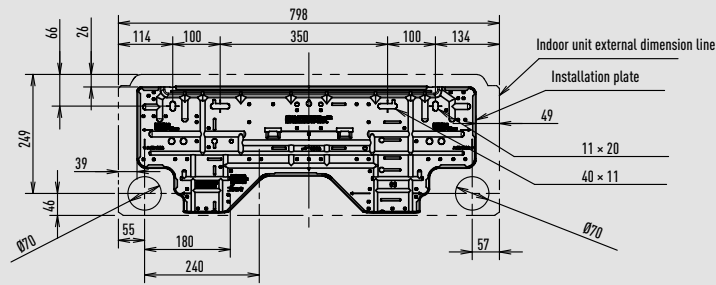

Wall-mounted Etherea (from 1,6 to 4,2 kW).

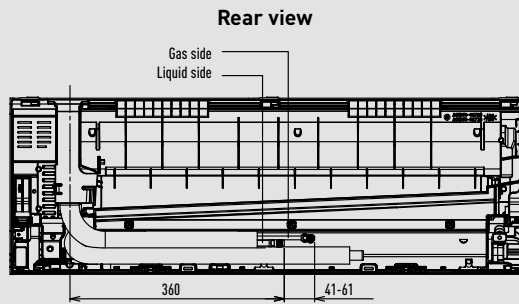
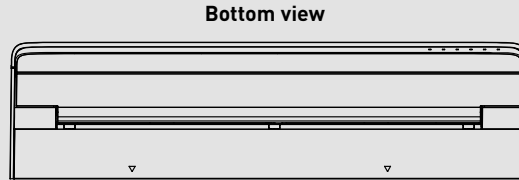
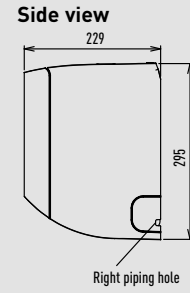
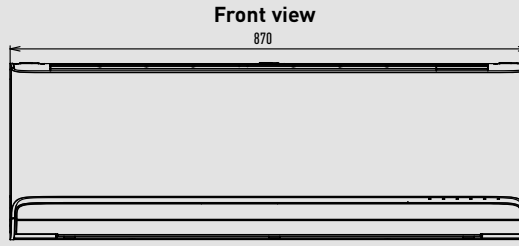
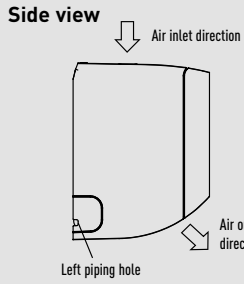

Relative position between the indoor unit and the installation plate

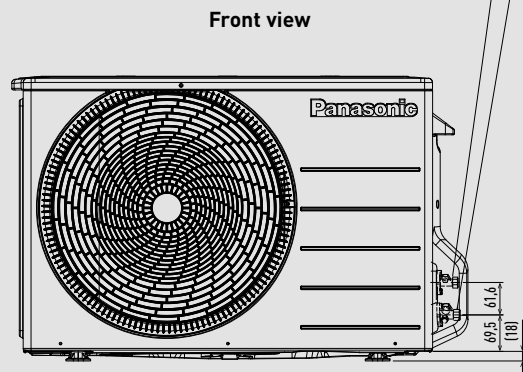
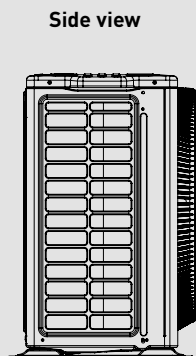
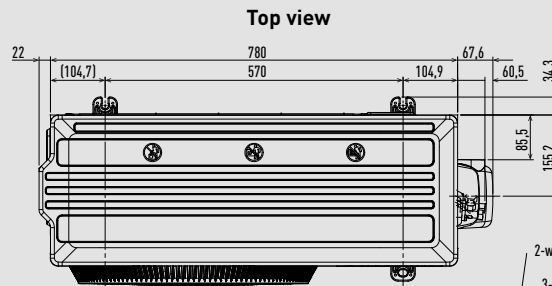
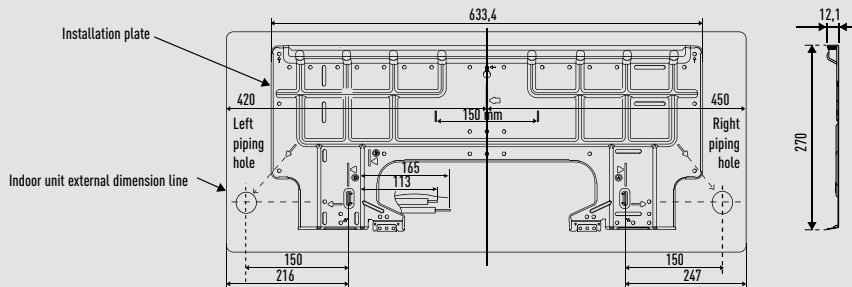

2-way valve at liquid side (high pressure)  
3-way valve at gas side (low pressure)

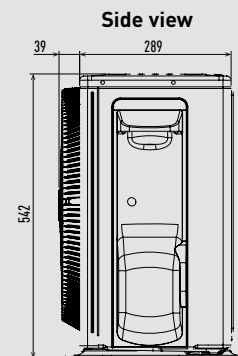

Wall-mounted Etherea (5,0 and 7,1 kW).

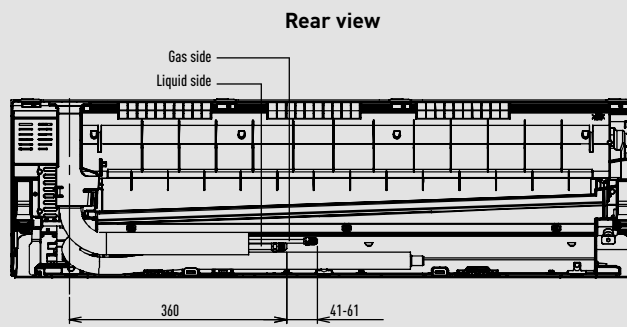
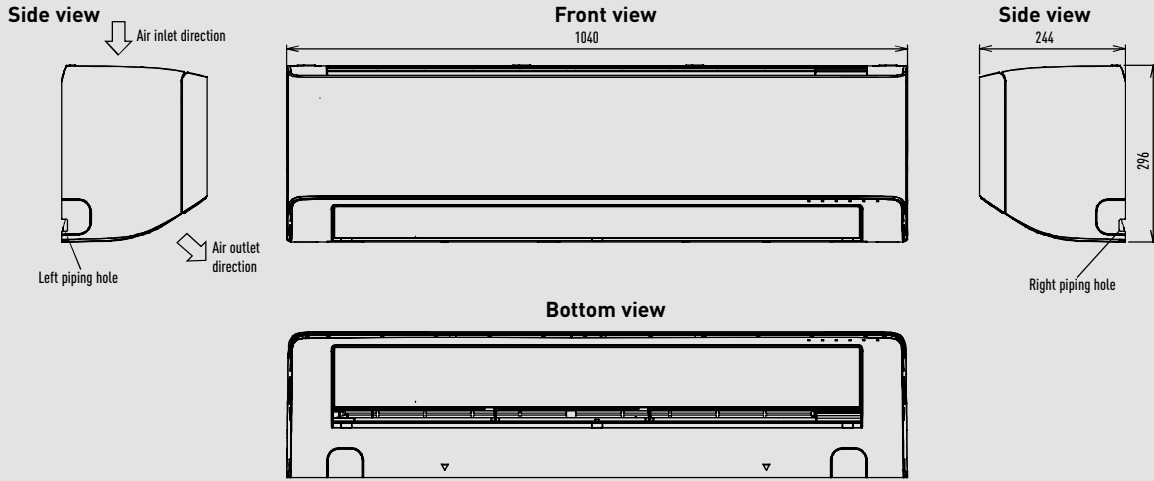

Relative position between the indoor unit and the installation plate

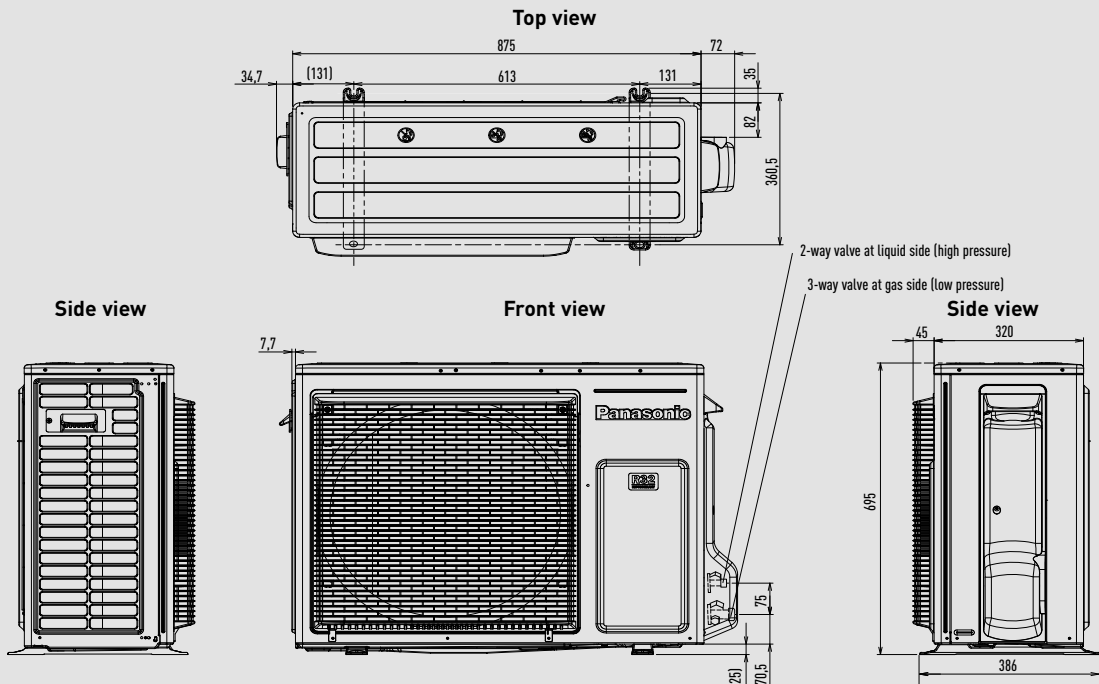
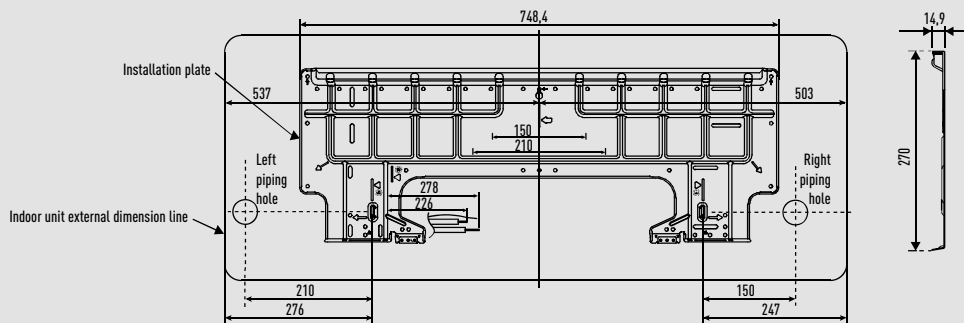

Wall-mounted TZ super-compact (from 1,6 to 5,0 kW).

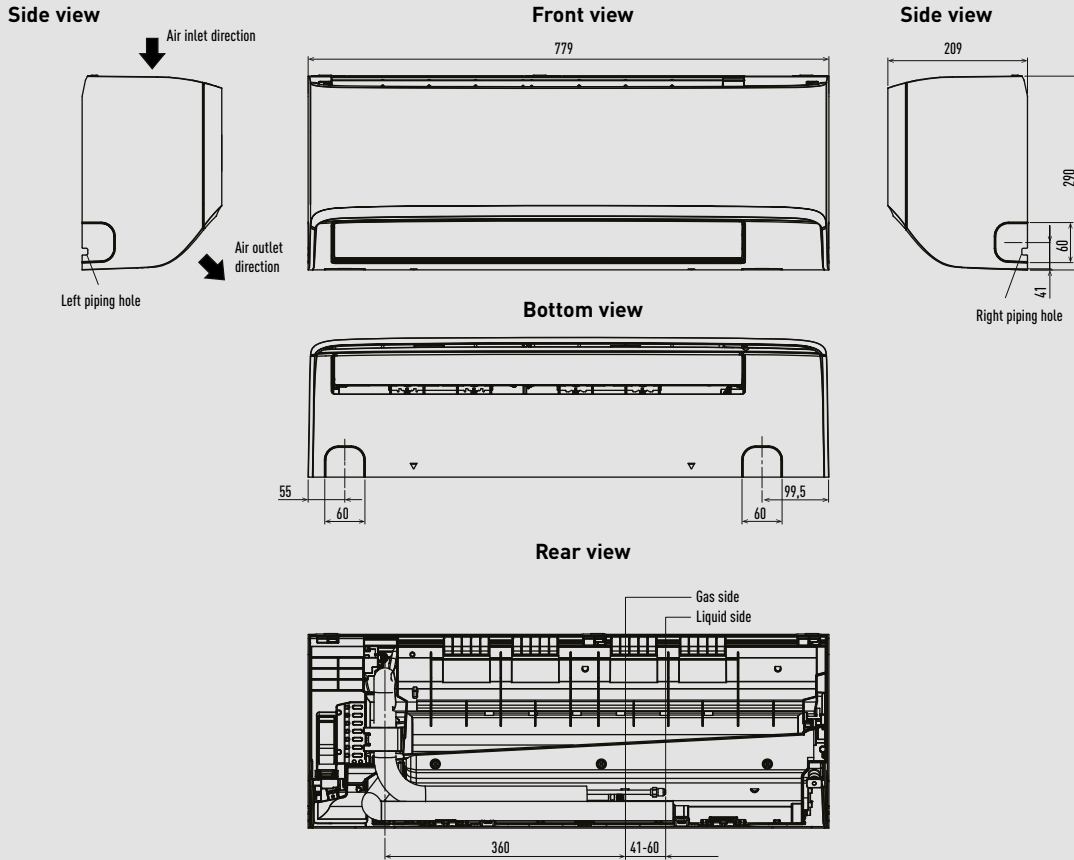

Relative position between the indoor unit and the installation plate

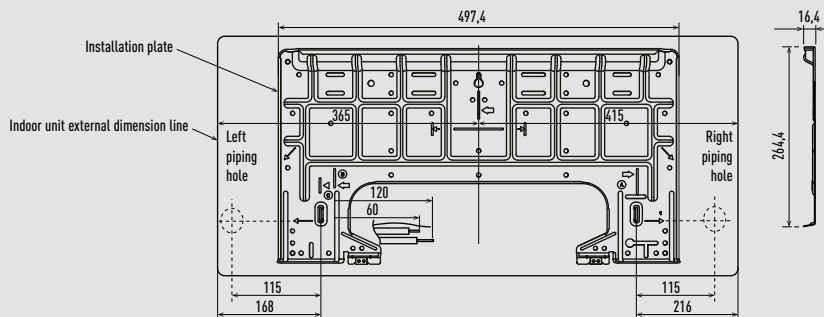

CU-TZ20ZKE / CU-TZ25ZKE / CU-TZ35ZKE / CU-TZ42ZKE

CU-TZ50ZKE

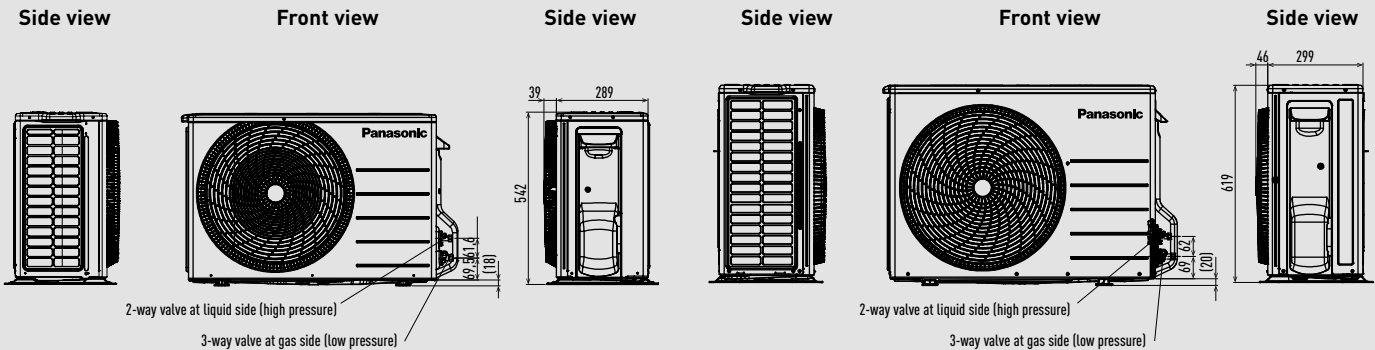
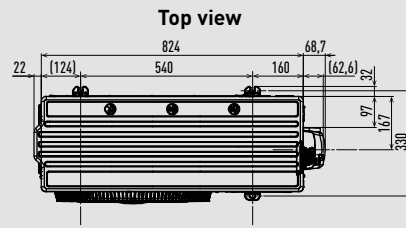
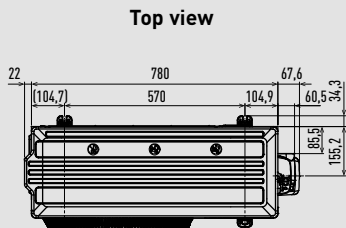

Unit: mm

Wall-mounted TZ super-compact (6,0 and 7,1 kW).

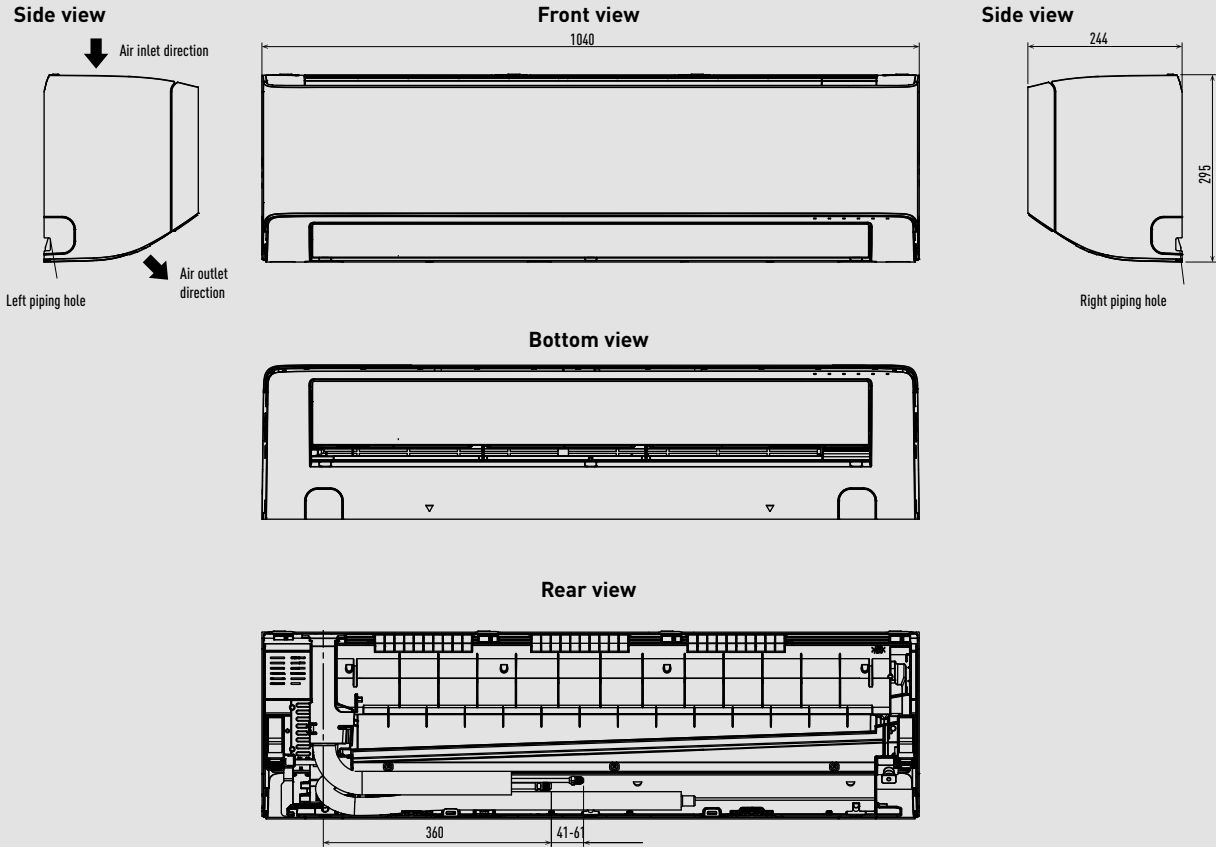

Relative position between the indoor unit and the installation plate

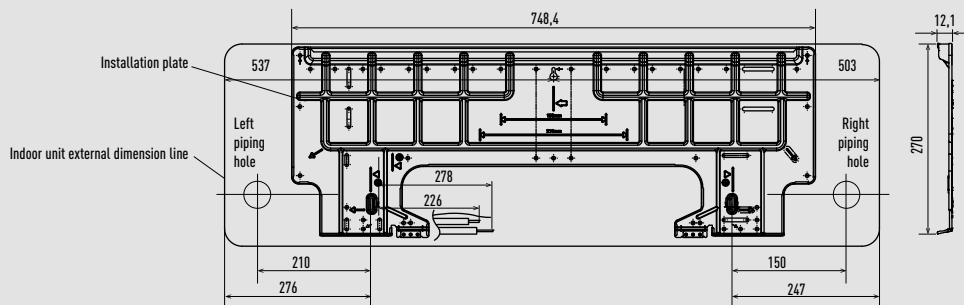

CU-TZ60ZKE

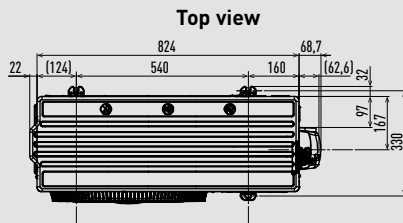

CU-TZ71ZKE

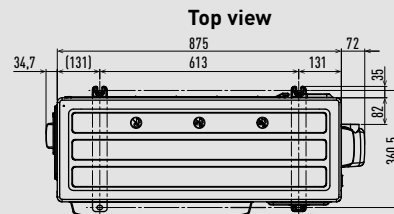

Side view

Front view

Side view

Side view

Front view

Side view

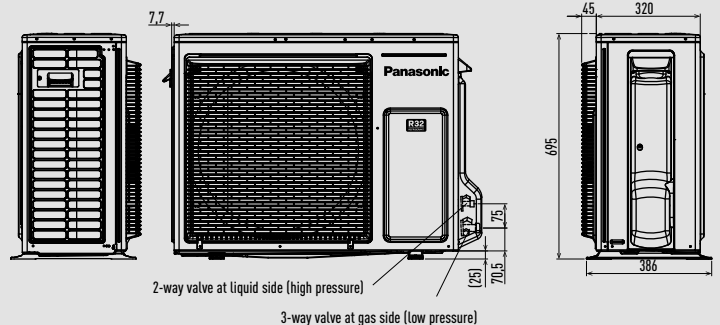
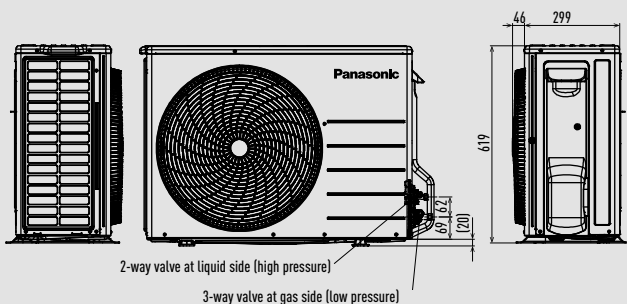

Unit: mm

Wall-mounted BZ super-compact.

Side view

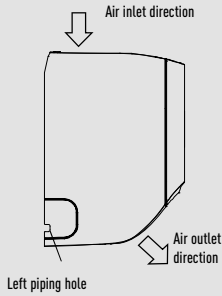

Front view



Side view

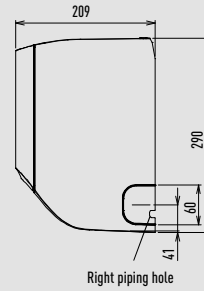

Bottom view

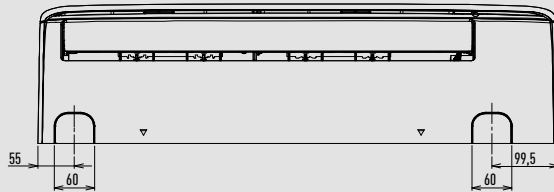

Rear view

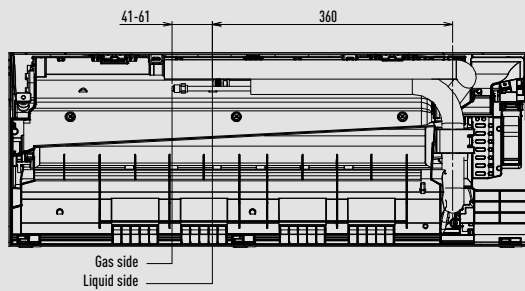

Relative position between the indoor unit and the installation plate

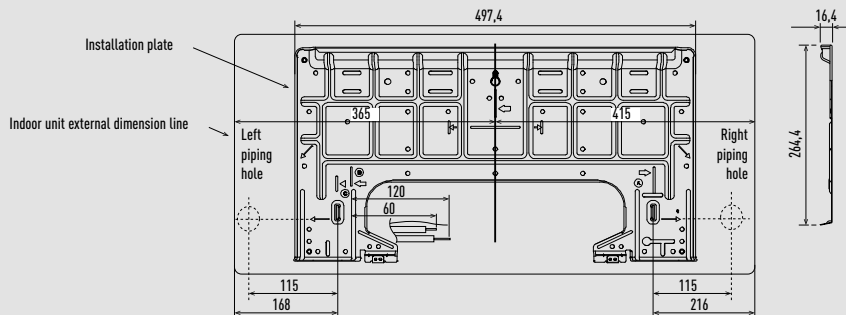

CU-BZ25ZKE / CU-BZ35ZKE

Top view

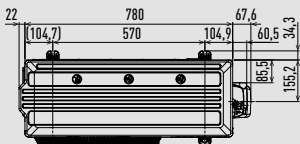

Front view

Side view

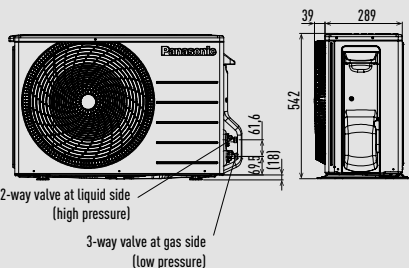

CU-BZ50ZKE

Top view

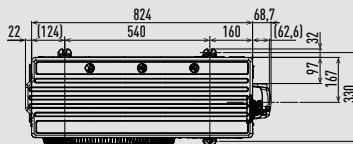

Front view

Side view

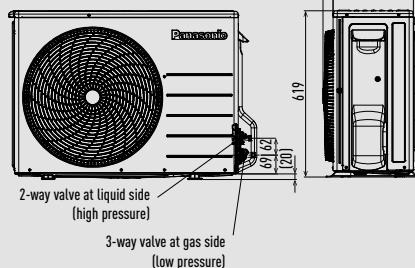

CU-BZ60ZKE

Top view

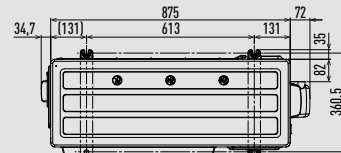

Front view

Side view

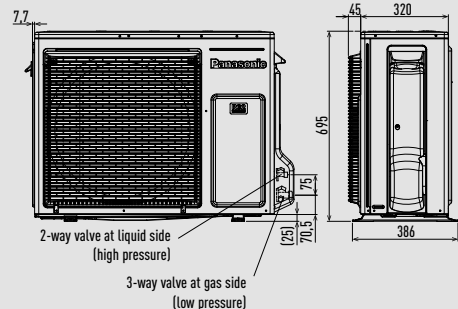

Unit: mm

Wall-mounted UZ super-compact.

Side view

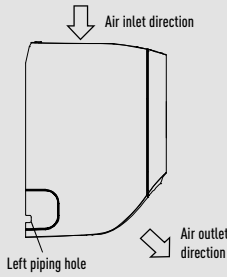

Front view



Side view

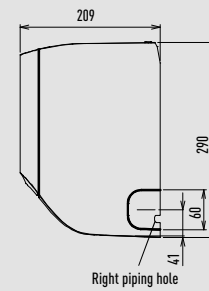

Bottom view

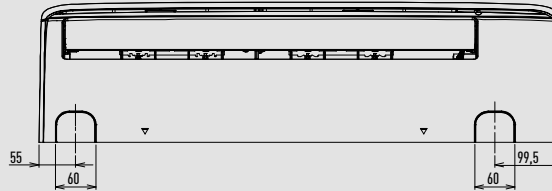

Rear view

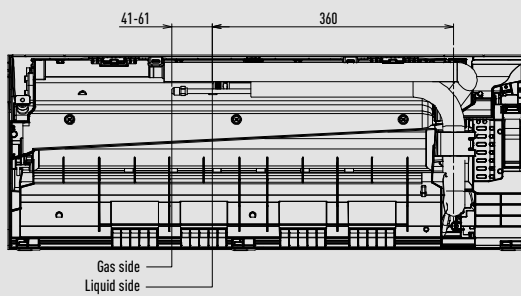

Relative position between the indoor unit and the installation plate

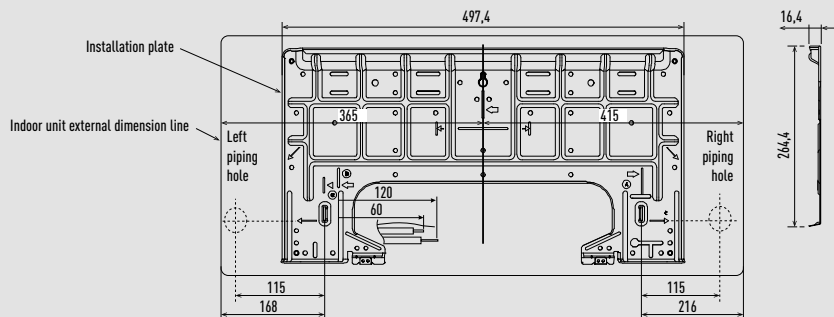

CU-UZ25ZKE / CU-UZ35ZKE

Top view

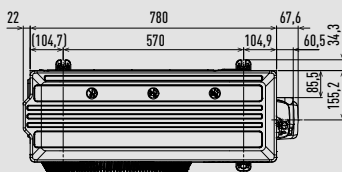

CU-UZ50ZKE

Top view

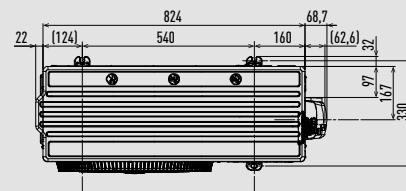

Side view

Front view

Side view

Side view

Front view

Side view

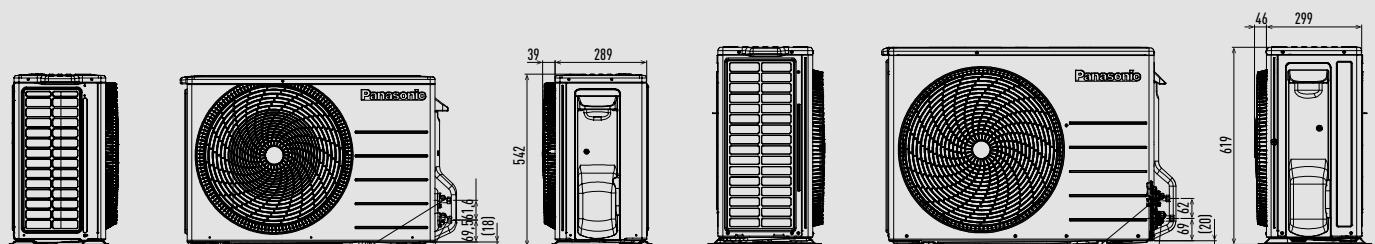

2-way valve at liquid side (high pressure)  
3-way valve at gas side (low pressure)

2-way valve at liquid side (high pressure)  
3-way valve at gas side (low pressure)

Unit: mm

Floor console.

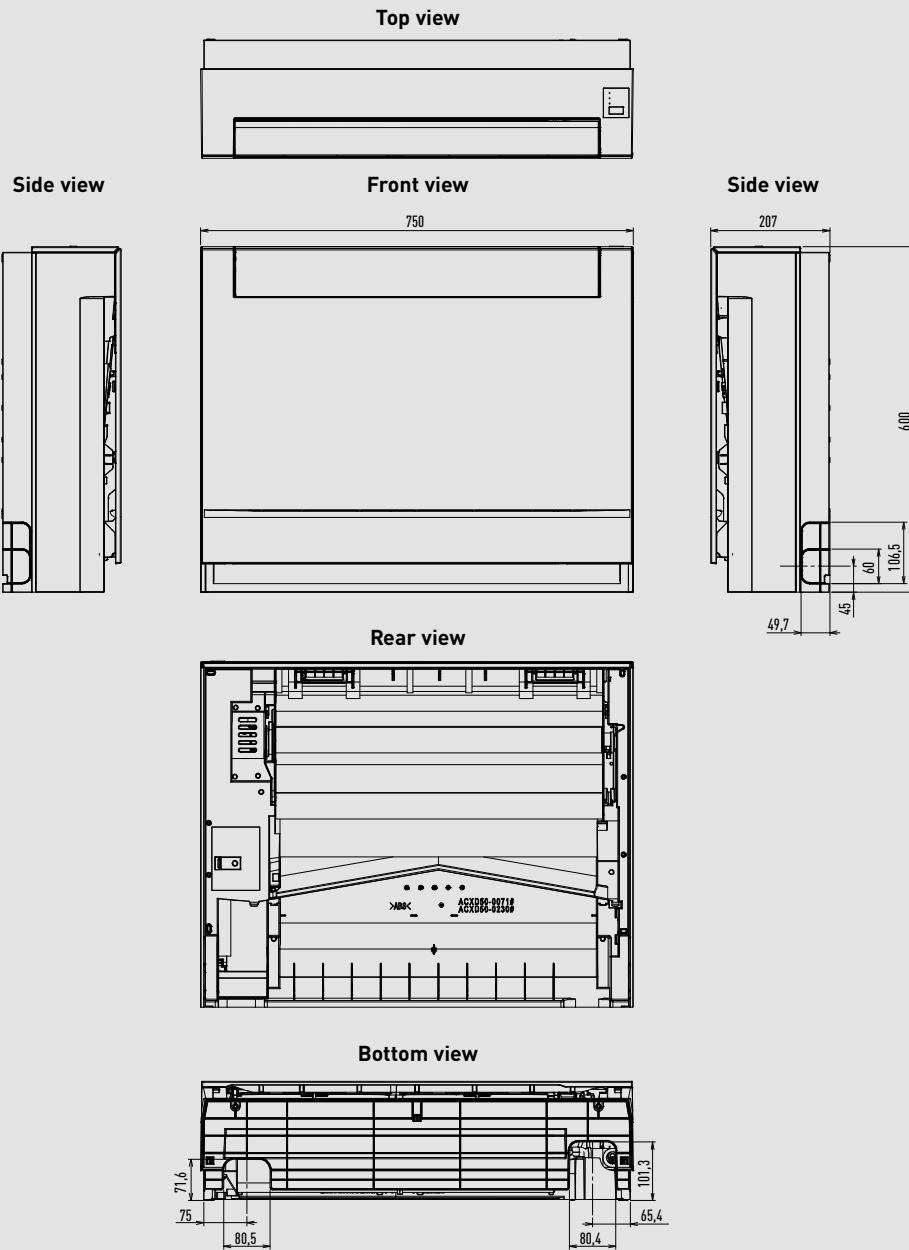

CU-Z25UBEA

CU-Z35UBEA

CU-Z50UBEA

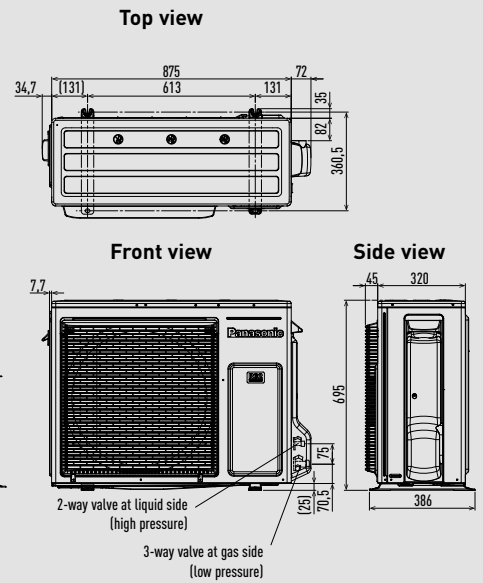
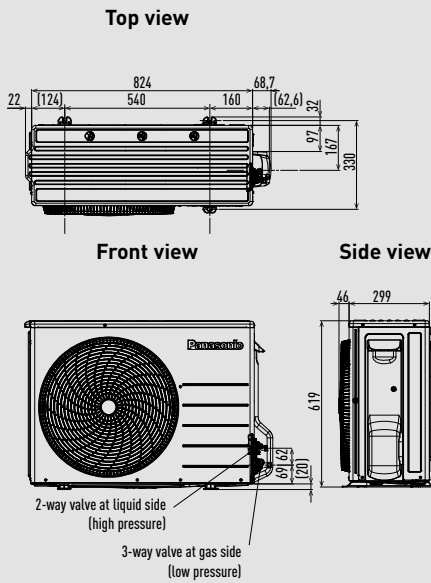
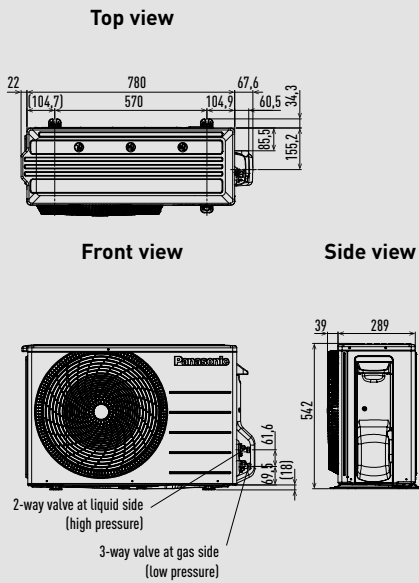

Unit: mm

Low static pressure hide-away.

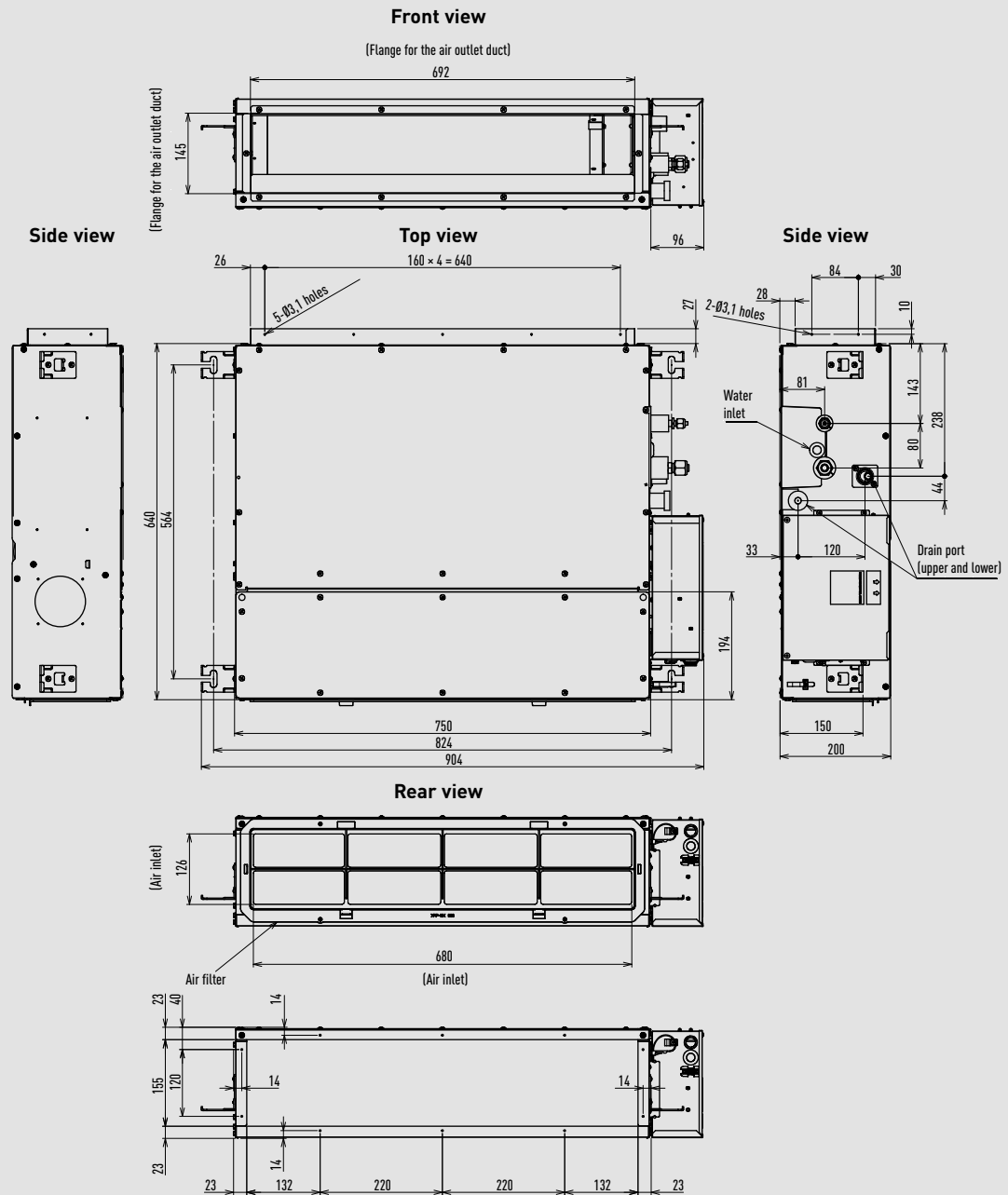

CU-Z25UBEA

CU-Z35UBEA

CU-Z50UBEA / CU-Z60UBEA

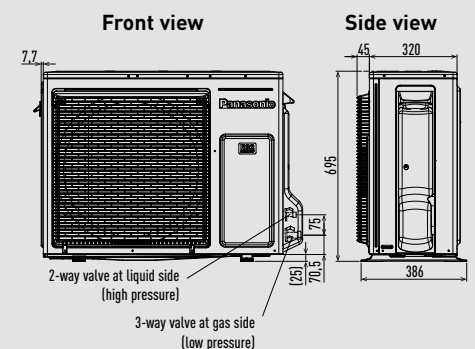
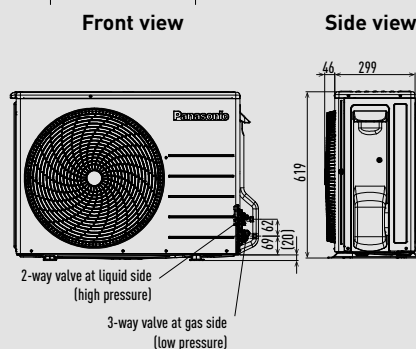
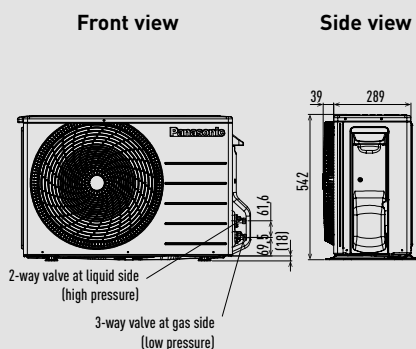
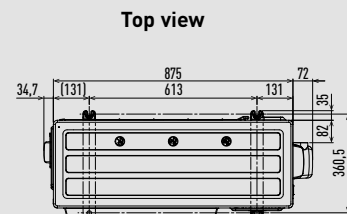
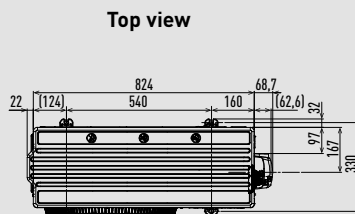
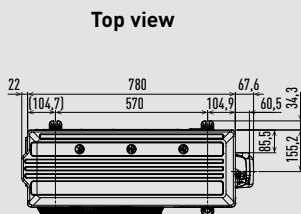

Unit: mm

Indoor unit Free Multi system Z - 4 Way 60x60 cassette.

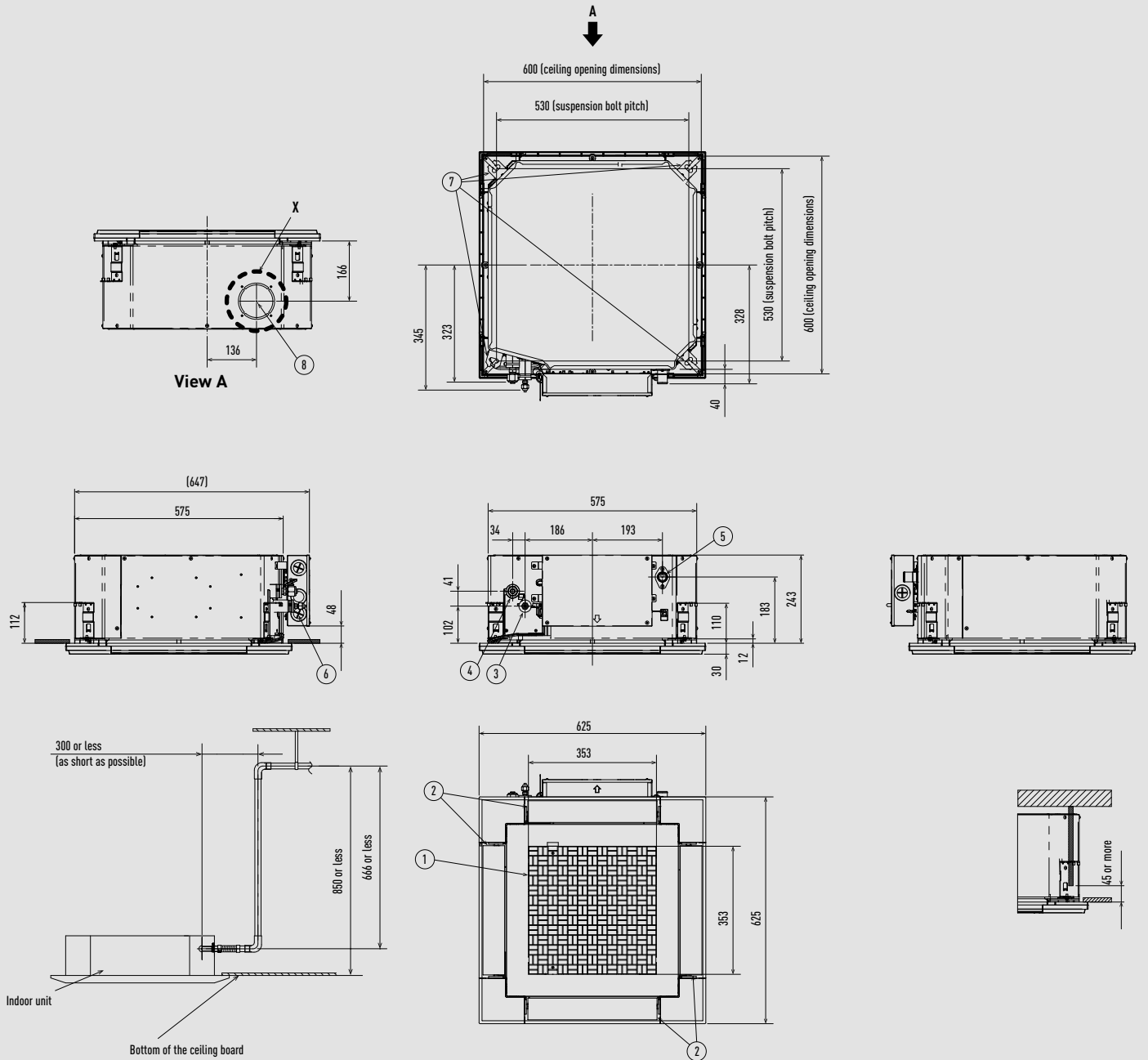

\* Length of supplied drain piping= 250 mm.

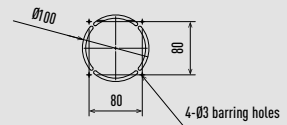

Detailed view X

Type	20-50	60
1 Air inlet		
2 Air outlet		
3 Refrigerant piping (liquid)	Ø6,35 (flared)	Ø9,52 (flared)
4 Refrigerant piping (gas)	Ø12,70 (flared)	Ø15,88 (flared)
5 Drain piping connection port VP20		
6 Power supply port		
7 Suspension bolt hole (4-11x26 slot)		
8 Fresh air inlet duct connection port (Ø100) <sup>1)</sup>		

1) Necessary to attach duct connecting flange (field supply).

Filter dimension: 362 x 362 x 15 mm.

Outdoor units Free Multi System Z.

CU-2Z35TBE / CU-2Z41TBE / CU-2Z50TBE

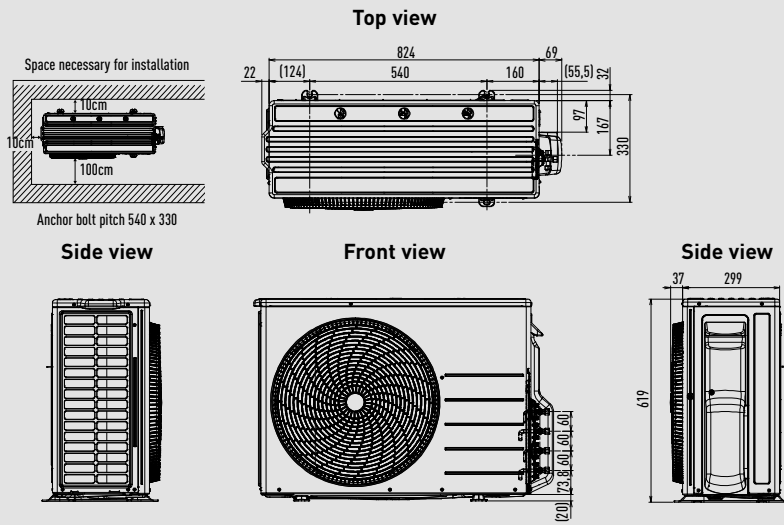

CU-3Z52TBE / CU-3Z68TBE / CU-4Z68TBE

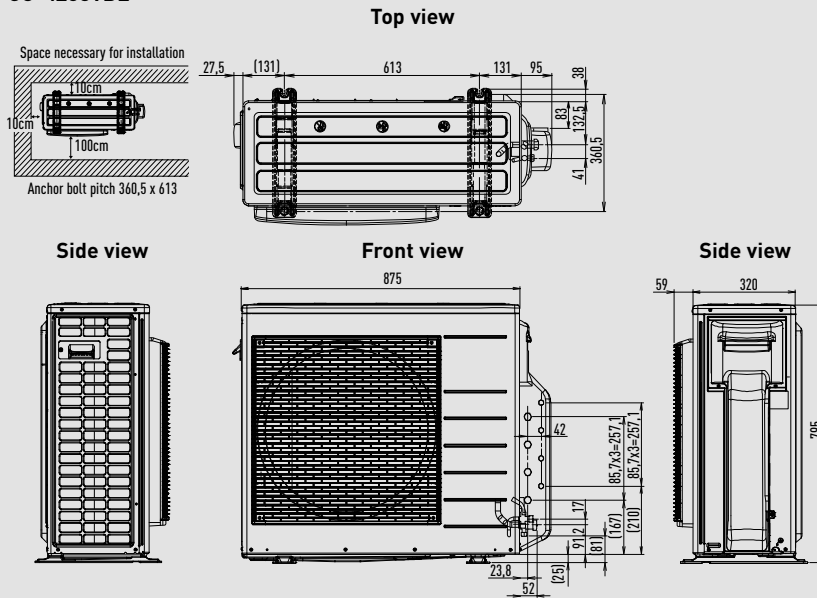

CU-4Z80TBE / CU-5Z90TBE

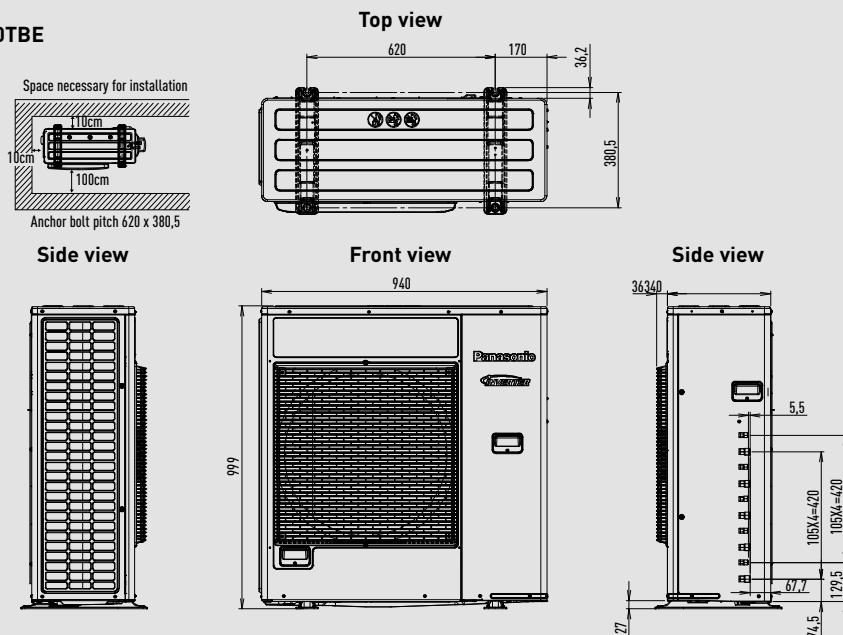

Outdoor units Multi Wall TZ.

CU-2TZ41TBE / CU-2TZ50TBE

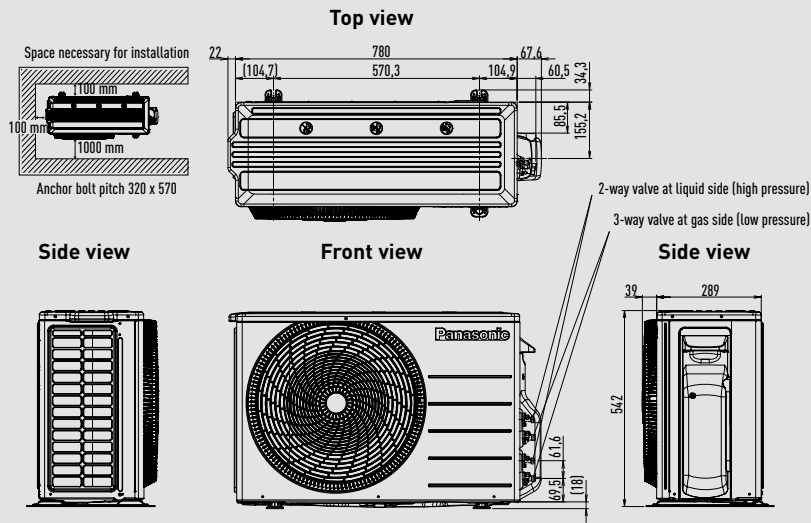

CU-3TZ52TBE

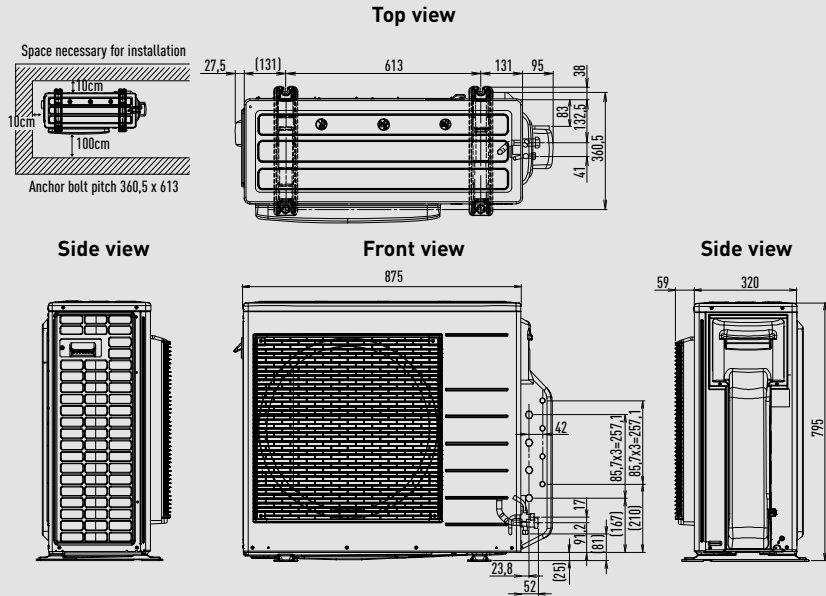

Wall-mounted Professional (from 2,5 to 4,2 kW).

Side view

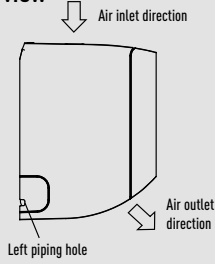

Front view

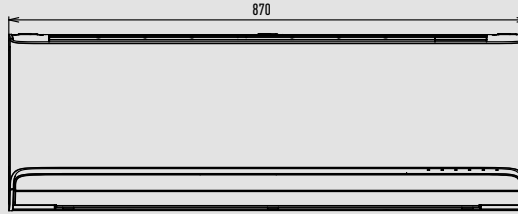

Side view

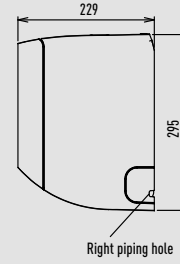

Bottom view

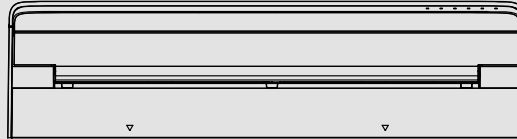

Rear view

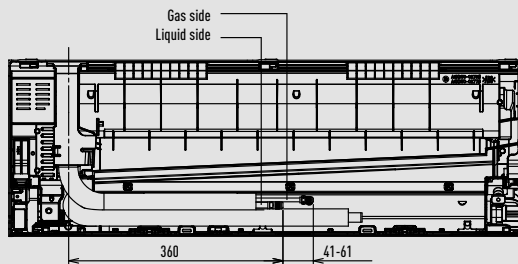

Relative position between the indoor unit and the installation plate

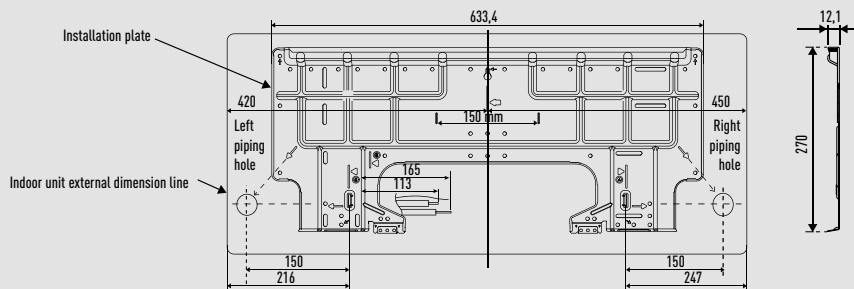

Top view

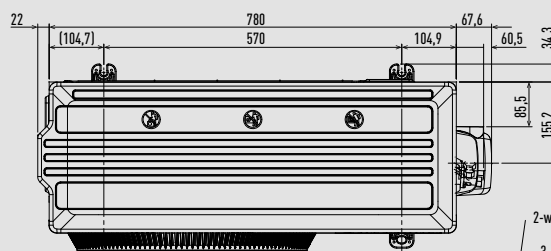

Side view

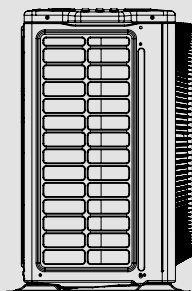

Front view

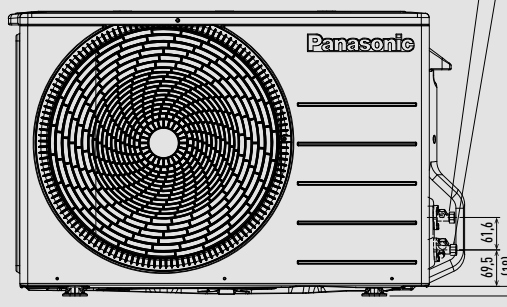

Side view

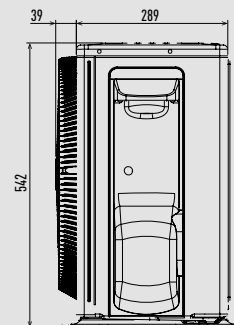

2-way valve at liquid side (high pressure)  
3-way valve at gas side (low pressure)

Wall-mounted Professional (5,0 and 7,1 kW).

Side view

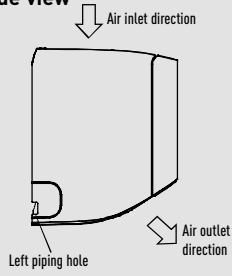

Front view

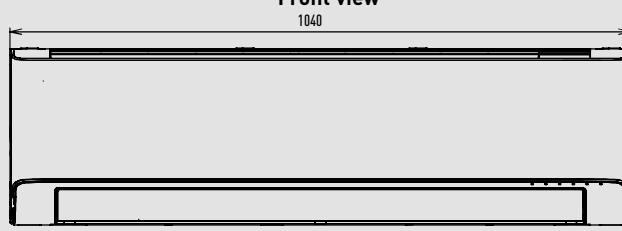

Side view

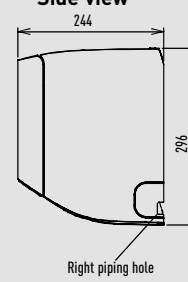

Bottom view

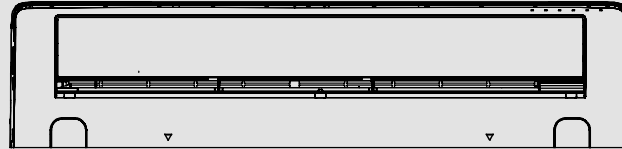

Rear view

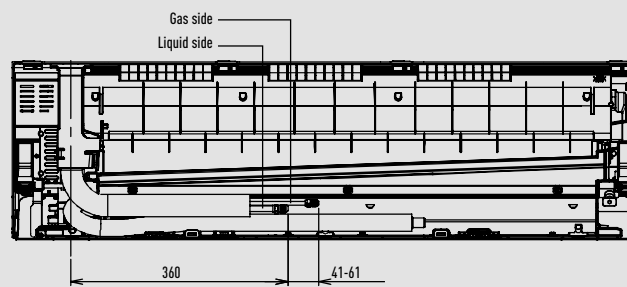

Relative position between the indoor unit and the installation plate

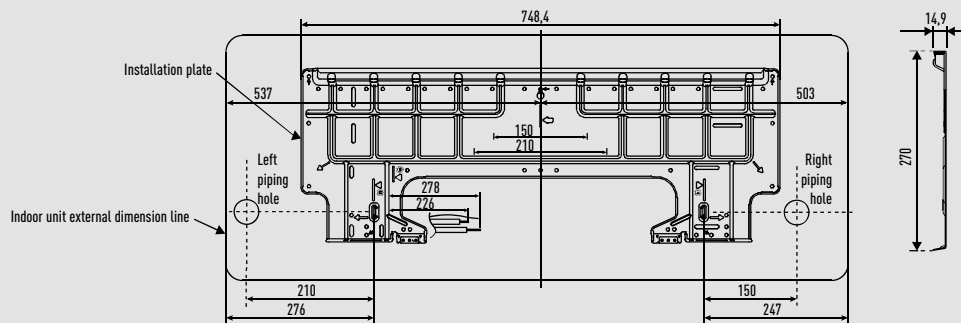

Top view

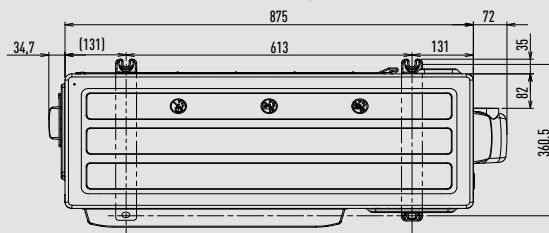

2-way valve at liquid side (high pressure)

3-way valve at gas side (low pressure)

Side view

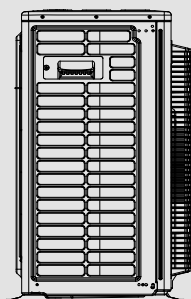

Front view

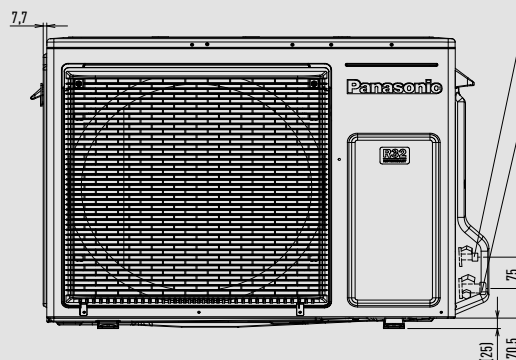

Side view

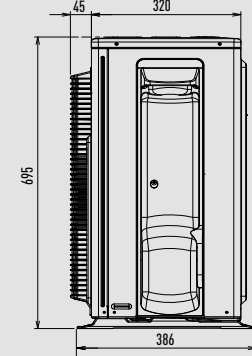

Unit: mm

PACi NX Series wall-mounted.

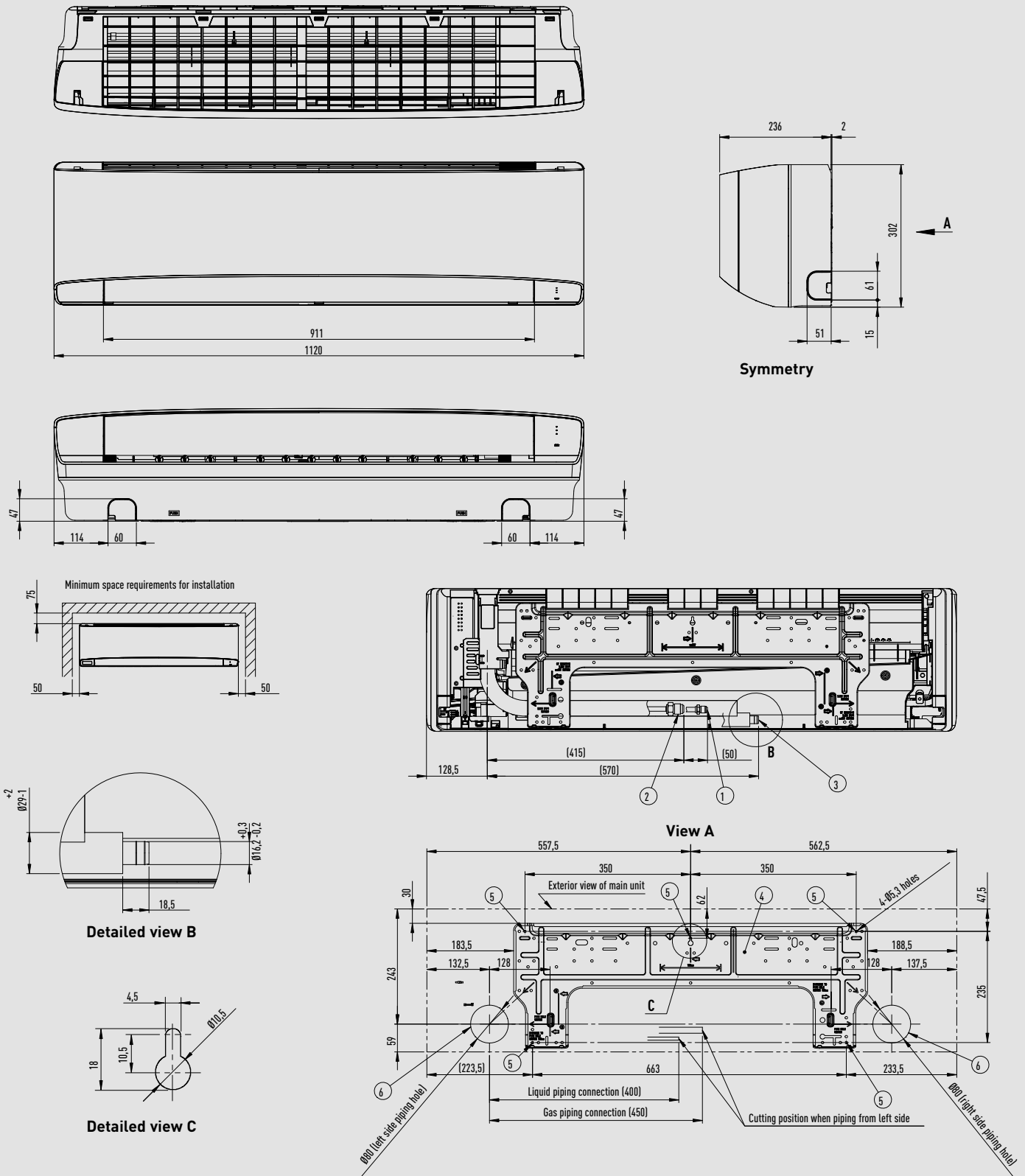

Type	S-3650PK4E	S-6010PK4E
1 Refrigerant piping (liquid)	$\varnothing 6,35$ (flared)	$\varnothing 9,52$ (flared) <sup>1)</sup>
2 Refrigerant piping (gas)	$\varnothing 12,70$ (flared)	60: $\varnothing 15,88$ (flared) <sup>2)</sup> 71: $\varnothing 15,88$ (flared) 100: $\varnothing 15,88$ (flared)
3 Drain hose		
4 Rear panel		
5 Rear panel fixing holes ( $\varnothing 5,3$ holes or as shown in figure "C")		
6 Piping and wiring holes ( $\varnothing 80$ )		

1) When connecting with U-60PZ3E5, U-71PZ3E5 or U-60PZH3E5, connect the liquid socket piping ( $\varnothing 9,52 - \varnothing 6,35$ ) to the liquid piping side indoor unit.  
 2) When connecting with U-60PZ3E5 or U-60PZH3E5, connect the gas socket piping ( $\varnothing 15,88 - \varnothing 12,70$ ) to the gas piping side indoor unit.

PACi NX Series 4 way 60x60 cassette.

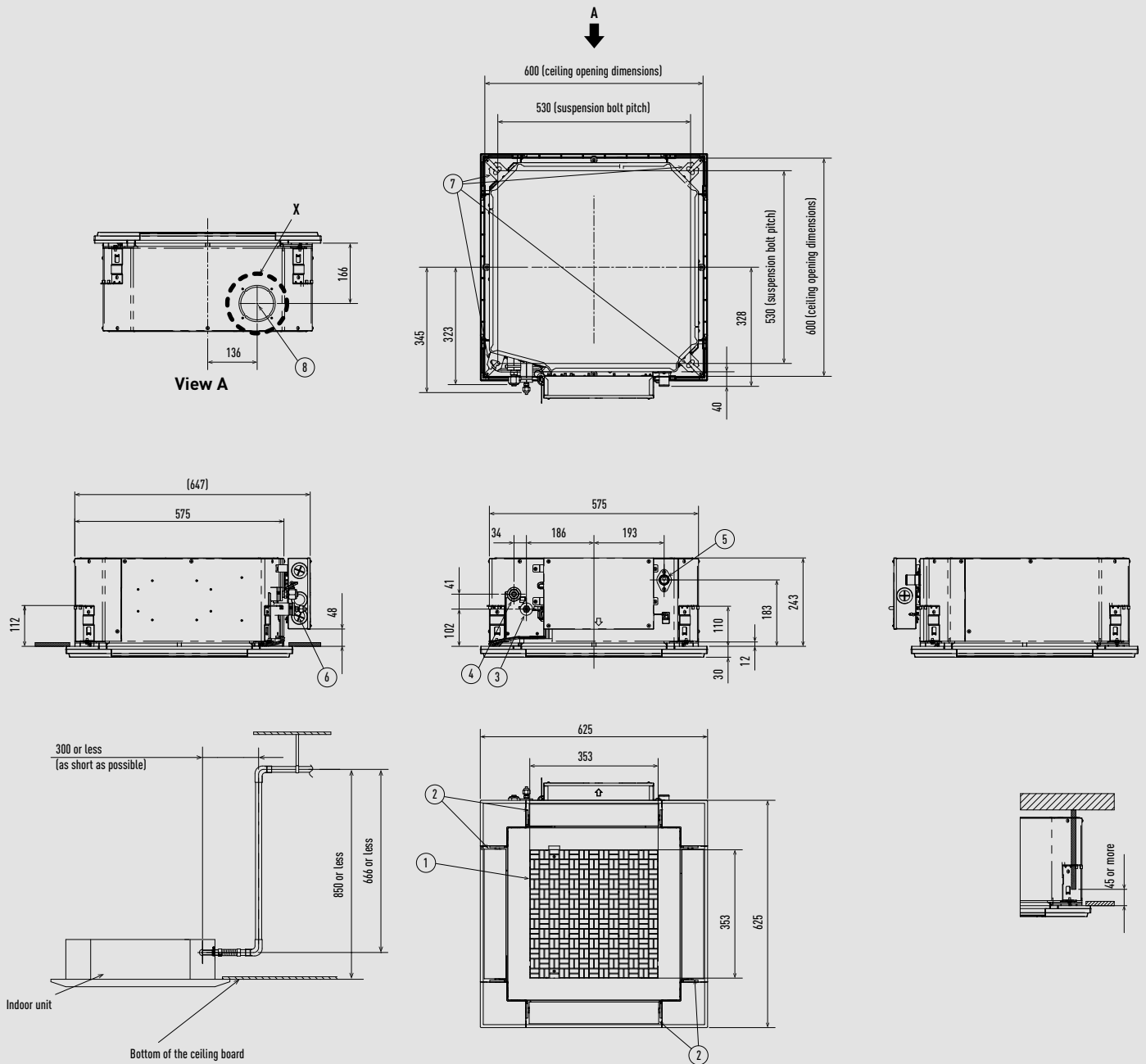

\* Length of supplied drain piping= 250 mm.

Type	25-50	60
1 Air inlet		
2 Air outlet		
3 Refrigerant piping (liquid)	Ø6,35 (flared)	Ø9,52 (flared) <sup>1)</sup>
4 Refrigerant piping (gas)	Ø12,70 (flared)	Ø15,88 (flared) <sup>2)</sup>
5 Drain piping connection port VP20		
6 Power supply port		
7 Suspension bolt hole (4-11x26 slot)		
8 Fresh air inlet duct connection port (Ø100) <sup>3)</sup>		

1) When connecting with U-60PZ3E5A or U-60PZH3E5, connect the liquid socket piping (Ø9,52 - Ø6,35) to the liquid piping side indoor unit.  
 2) When connecting with U-60PZ3E5A or U-60PZH3E5, connect the gas socket piping (Ø15,88 - Ø12,70) to the gas piping side indoor unit.  
 3) Necessary to attach duct connecting flange (field supply).

Filter dimension: 362 x 362 x 15 mm.

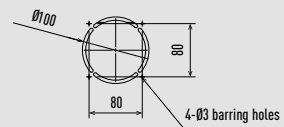

Detailed view X

PACi NX Series 4 way 90x90 cassette.

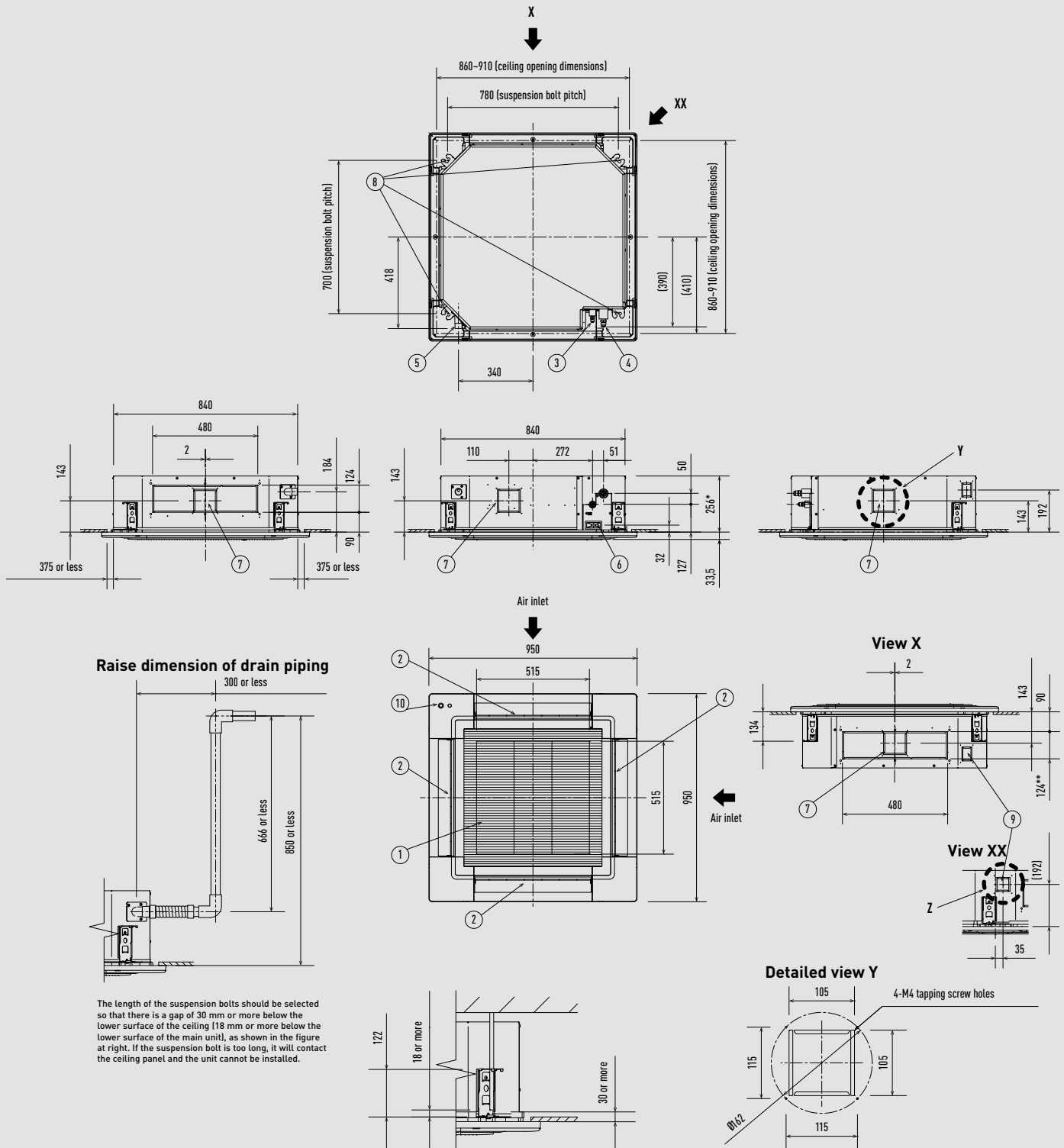

Raise dimension of drain piping

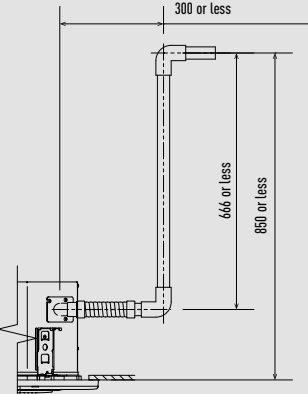

The length of the suspension bolts should be selected so that there is a gap of 30 mm or more below the lower surface of the ceiling (18 mm or more below the lower surface of the main unit), as shown in the figure at right. If the suspension bolt is too long, it will contact the ceiling panel and the unit cannot be installed.

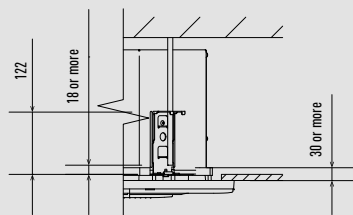

Type	S-3650PU3E	S-6071PU3E	S-1014PU3E
1 Air inlet			
2 Air outlet			
3 Refrigerant piping (liquid)	Ø6,35 (flared)	Ø9,52 (flared) <sup>1)</sup>	Ø9,52 (flared)
4 Refrigerant piping (gas)	Ø12,70 (flared)	60: Ø15,88 (flared) <sup>2)</sup> 71: Ø15,88 (flared)	Ø15,88 (flared)
5 Drain piping connection port VP25		Outer diameter 32 mm	
6 Power supply port			
7 Suspension bolt hole		4-12x30 elongated hole	
8 Fresh air inlet duct connection port		Ø100 <sup>3)</sup>	
9 Suspension bolt hole		4-12x30 elongated hole	
10 Econavi sensor (only CZ-KPU3A or CZ-KPU3AW)			

1) When connecting with U-60PZ3E5, U-71PZ3E5 or U-60PZH3E5, connect the liquid socket piping (Ø9,52 - Ø6,35) to the liquid piping side indoor unit.

2) When connecting with U-60PZ3E5 or U-60PZH3E5, connect the gas socket piping (Ø15,88 - Ø12,70) to the gas piping side indoor unit.

3) Necessary to attach duct connecting flange (field supply).

Filter dimension: 520 x 520 x 15 mm.

\* 319 mm for S-1014PU3E.

\*\* 187 mm for S-1014PU3E.

Unit: mm

PACi NX Series ceiling (S-3650PT3E).

Detailed view of air inlet duct connection port

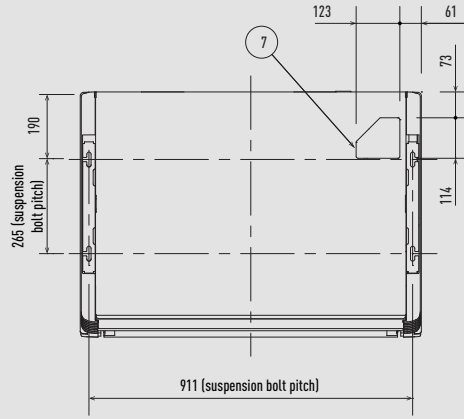
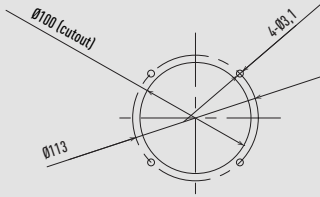

Distance of each exposed bolt must be of equal length within 50 mm

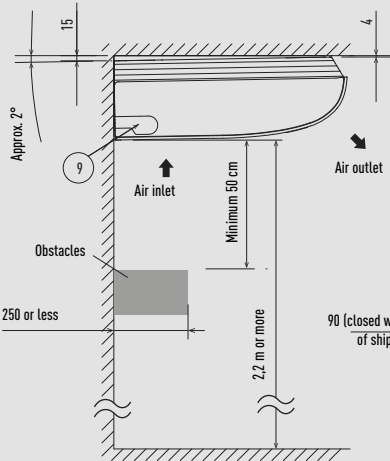
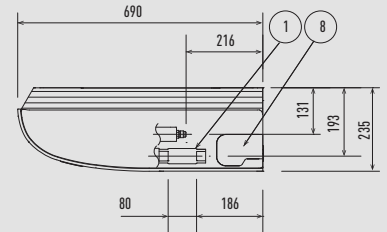
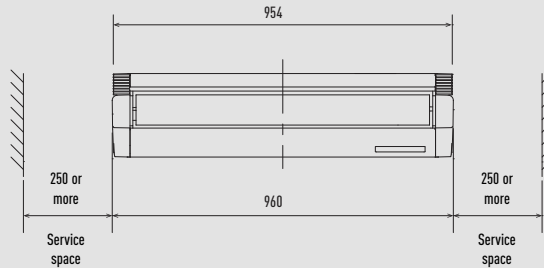
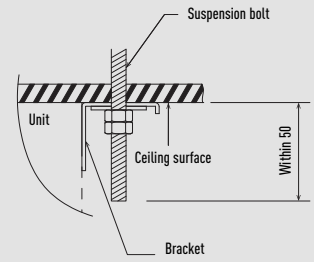

Side view

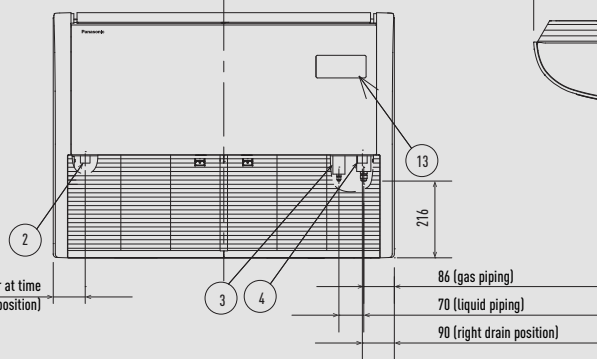

Hole position of indoor unit rear-side (figure shows view from front)

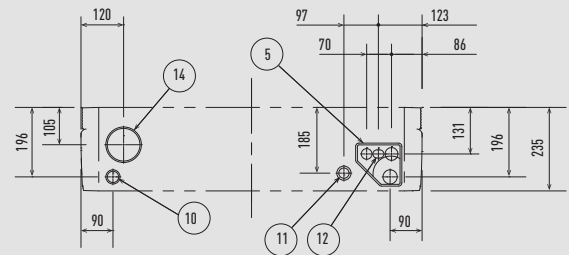

Piping hole position on wall surface (figure shows view from front)

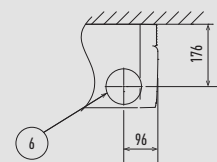

1	Drain piping connection port VP20	Inside diameter 26 mm, drain hose supplied
2	Left drain position	
3	Refrigerant piping (liquid)	Ø6,35mm (flared)
4	Refrigerant piping (gas)	Ø12,7mm (flared)
5	Cover of rear piping hole	
6	Piping hole on wall surface	Ø100 mm
7	Upper side piping port	
8	Right side drain hose outlet port (cutout)	
9	Left side drain hose outlet port (cutout)	
10	Left-rear side drain hose outlet port (cutout)	
11	Power inlet port	
12	Remote control wiring and inter-unit wiring inlet port	
13	Wireless remote controller receiver installation location	
14	Air inlet duct connection port	Ø100 mm (cutout)

Filter dimension: 421 x 250 x 16 mm x 2 pcs.

Unit: mm

PACi NX Series ceiling (S-6071PT3E).

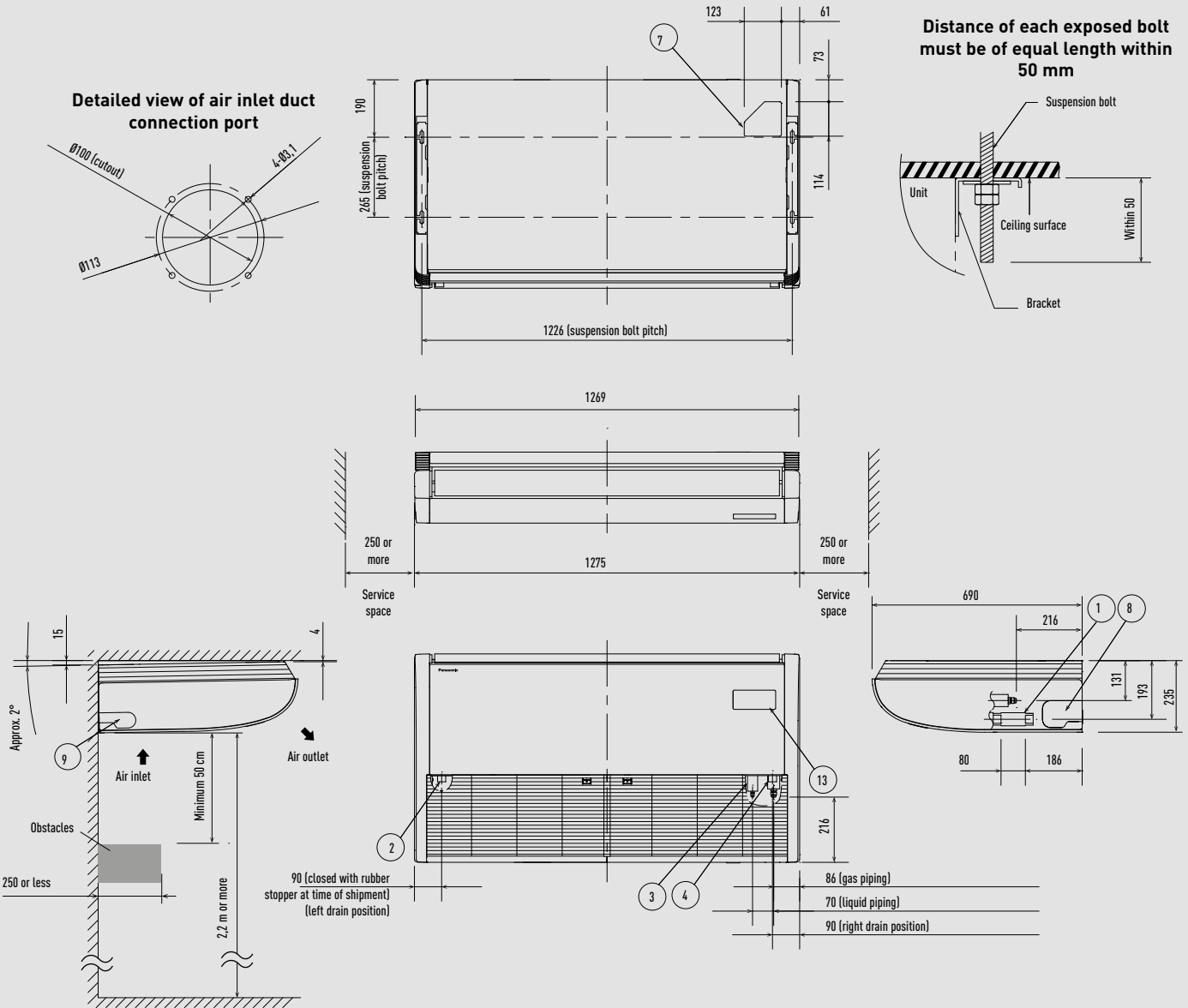

**Hole position of indoor unit rear-side (figure shows view from front)**

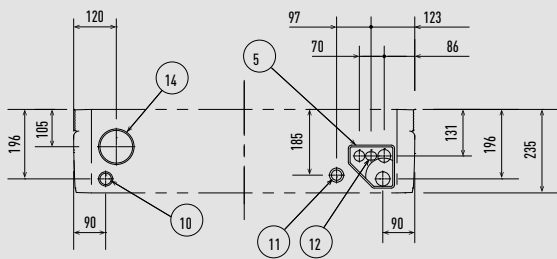

**Piping hole position on wall surface (figure shows view from front)**

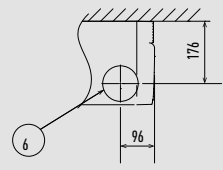

1	Drain piping connection port VP20	Inside diameter 26 mm, drain hose supplied
2	Left drain position	
3	Refrigerant piping (liquid)	Ø9,52 (flared) <sup>1)</sup>
4	Refrigerant piping (gas)	Ø15,88 (flared) <sup>2)</sup>
5	Cover of rear piping hole	
6	Piping hole on wall surface	Ø100 mm
7	Upper side piping port	
8	Right side drain hose outlet port (cutout)	
9	Left side drain hose outlet port (cutout)	
10	Left-rear side drain hose outlet port (cutout)	
11	Power inlet port	
12	Remote control wiring and inter-unit wiring inlet port	
13	Wireless remote controller receiver installation location	
14	Air inlet duct connection port	Ø100 mm (cutout)

1) When connecting with U-60PZ3E5, U-71PZ3E5 or U-60PZH3E5, connect the liquid socket piping (Ø9,52 - Ø6,35) to the liquid piping side indoor unit.  
 2) When connecting with U-60PZ3E5 or U-60PZH3E5, connect the gas socket piping (Ø15,88 - Ø12,70) to the gas piping side indoor unit.

Filter dimension: 579 x 250 x 16 mm x 2 pcs.

Unit: mm

PACi NX Series ceiling (S-1014PT3E).

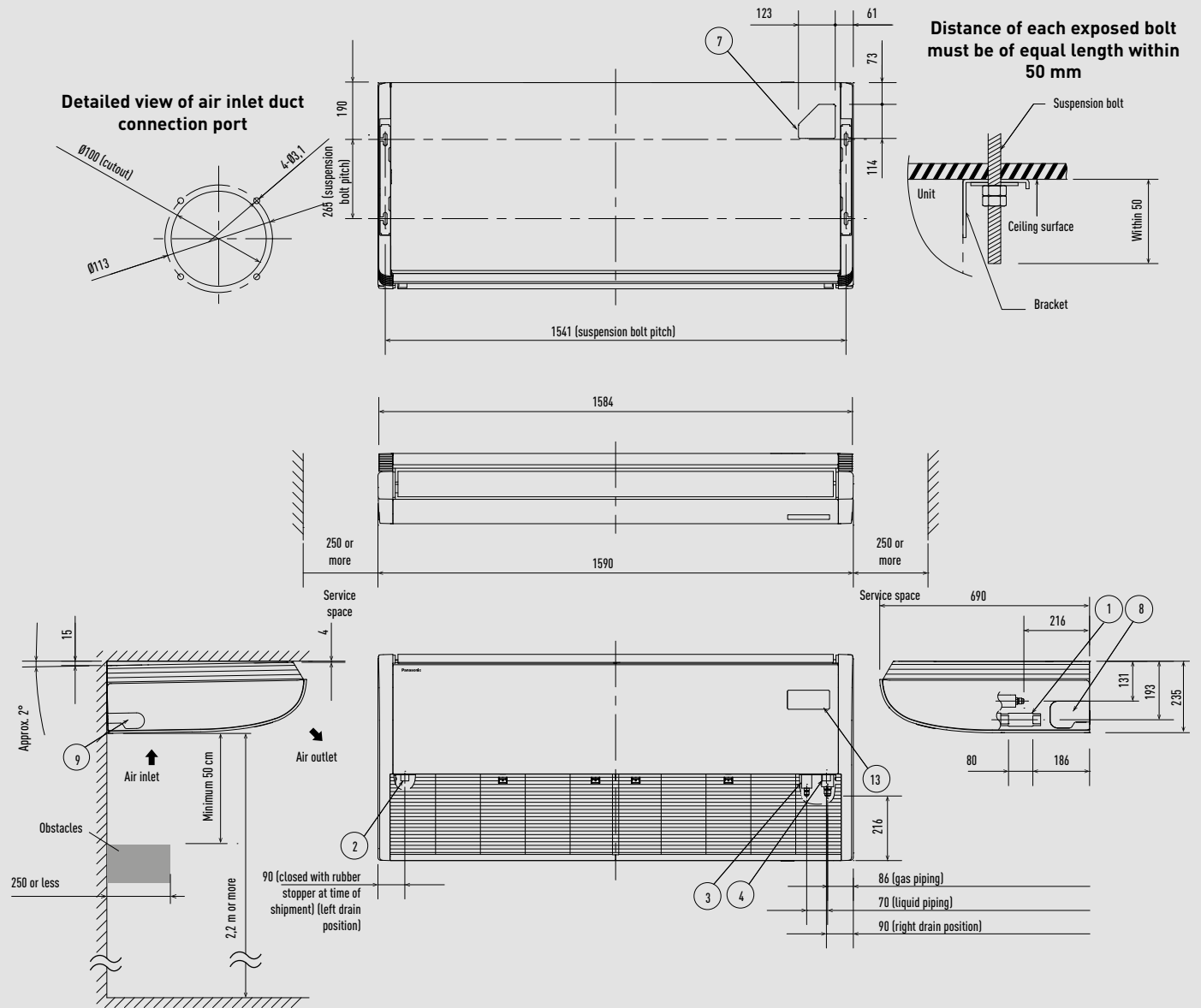

Hole position of indoor unit rear-side (figure shows view from front)

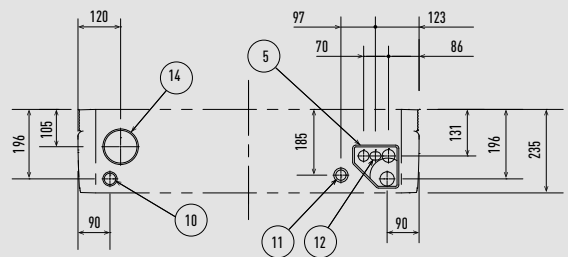

Piping hole position on wall surface (figure shows view from front)

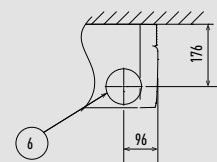

1	Drain piping connection port VP20	Inside diameter 26 mm, drain hose supplied
2	Left drain position	
3	Refrigerant piping (liquid)	Ø9,52 (flared)
4	Refrigerant piping (gas)	Ø15,88 (flared)
5	Cover of rear piping hole	
6	Piping hole on wall surface	Ø100 mm
7	Upper side piping port	
8	Right side drain hose outlet port (cutout)	
9	Left side drain hose outlet port (cutout)	
10	Left-rear side drain hose outlet port (cutout)	
11	Power inlet port	
12	Remote control wiring and inter-unit wiring inlet port	
13	Wireless remote controller receiver installation location	
14	Air inlet duct connection port	Ø100 mm (cutout)

Filter dimension: 736 x 250 x 16 mm x 2 pcs.

Unit: mm

PACi NX Series adaptive ducted unit.

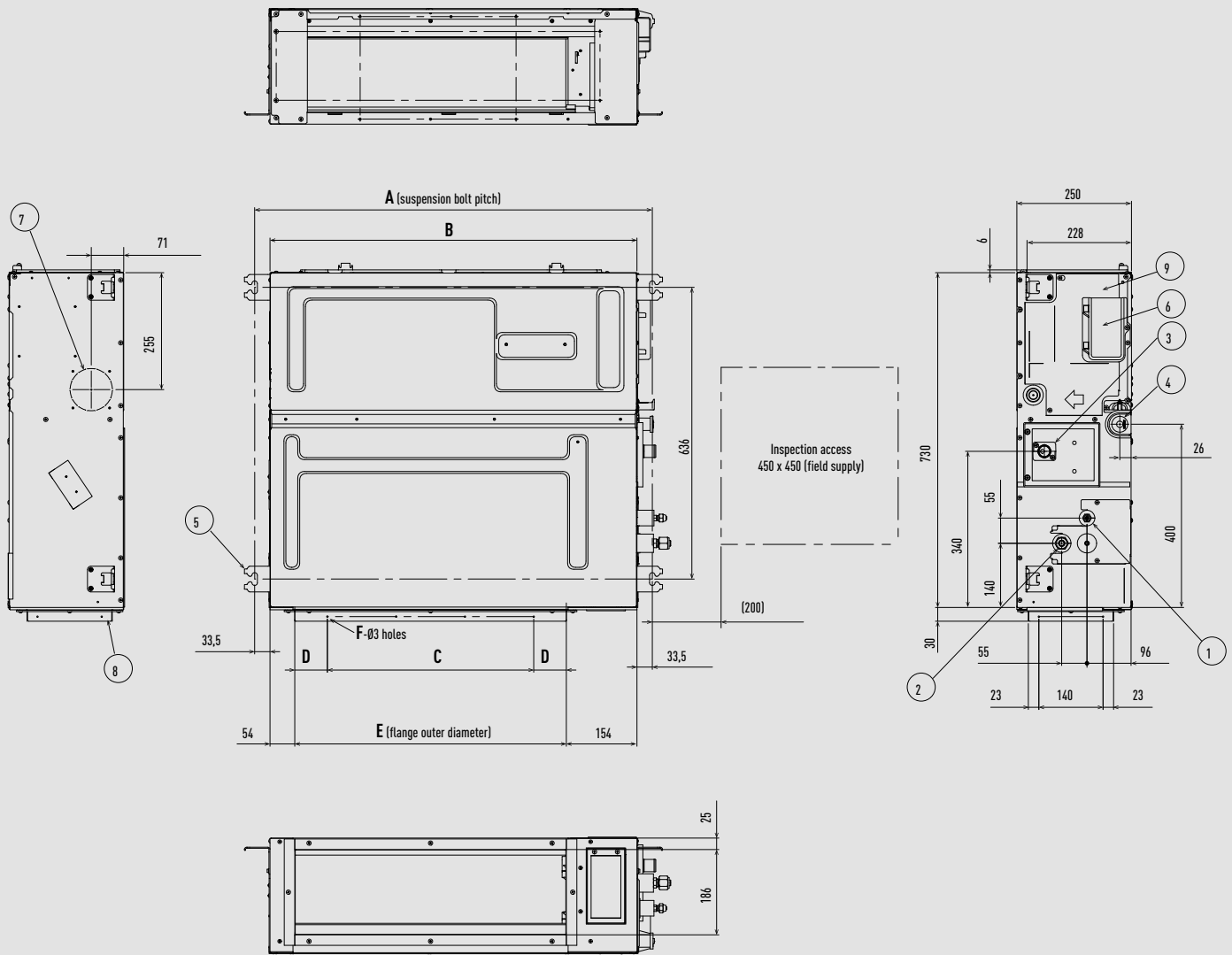

Type	A	B	C	D	E	F
	mm	mm	mm	mm	mm	Q'ty
S-3650PF3E	867	800	450 [pitch 150 x 3]	71	592	12
S-6071PF3E	1067	1000	750 [pitch 150 x 5]	21	792	16
S-1014PF3E	1467	1400	1050 [pitch 150 x 7]	71	1192	20

Type	S-3650PF3E	S-6071PF3E	S-1014PF3E
1 Refrigerant piping (liquid)	Ø6,35 (flared)	Ø9,52 (flared) <sup>1)</sup>	Ø9,52 (flared)
2 Refrigerant piping (gas)	Ø12,70 (flared)	60: Ø15,88 (flared) <sup>2)</sup> , 71: Ø15,88 (flared)	Ø15,88 (flared)
3 Upper drain piping connection port VP20	Outer diameter 26 mm, 200 mm flexible hose supplied		
4 Suspension lug	4-12x30		
5 Power supply port			
6 Bottom drain piping connection port VP20	Ø26 mm		
7 Fresh air inlet duct connection port	Ø100 <sup>3)</sup>		
8 Flange for flexible air outlet duct			
9 Electrical component box			

1) When connecting with U-60PZ3E5, U-71PZ3E5 or U-60PZH3E5, connect the liquid socket piping (Ø9,52 - Ø6,35) to the liquid piping side indoor unit.

2) When connecting with U-60PZ3E5 or U-60PZH3E5, connect the gas socket piping (Ø15,88 - Ø12,70) to the gas piping side indoor unit.

3) Necessary to attach duct connecting flange (field supply).

Filter dimension: 520 x 520 x 15 mm.

Big PACi NX high static pressure hide-away 20,0-25,0 kW.

- 1 Refrigerant piping (liquid) Ø12,70 (flared)
- 2 Refrigerant piping (gas) Ø22,22 (brazed)
- 3 Power supply port
- 4 Communication wiring port
- 5 Drain piping connection port VP25
- 6 Flange for air inlet duct
- 7 Flange for the air outlet duct

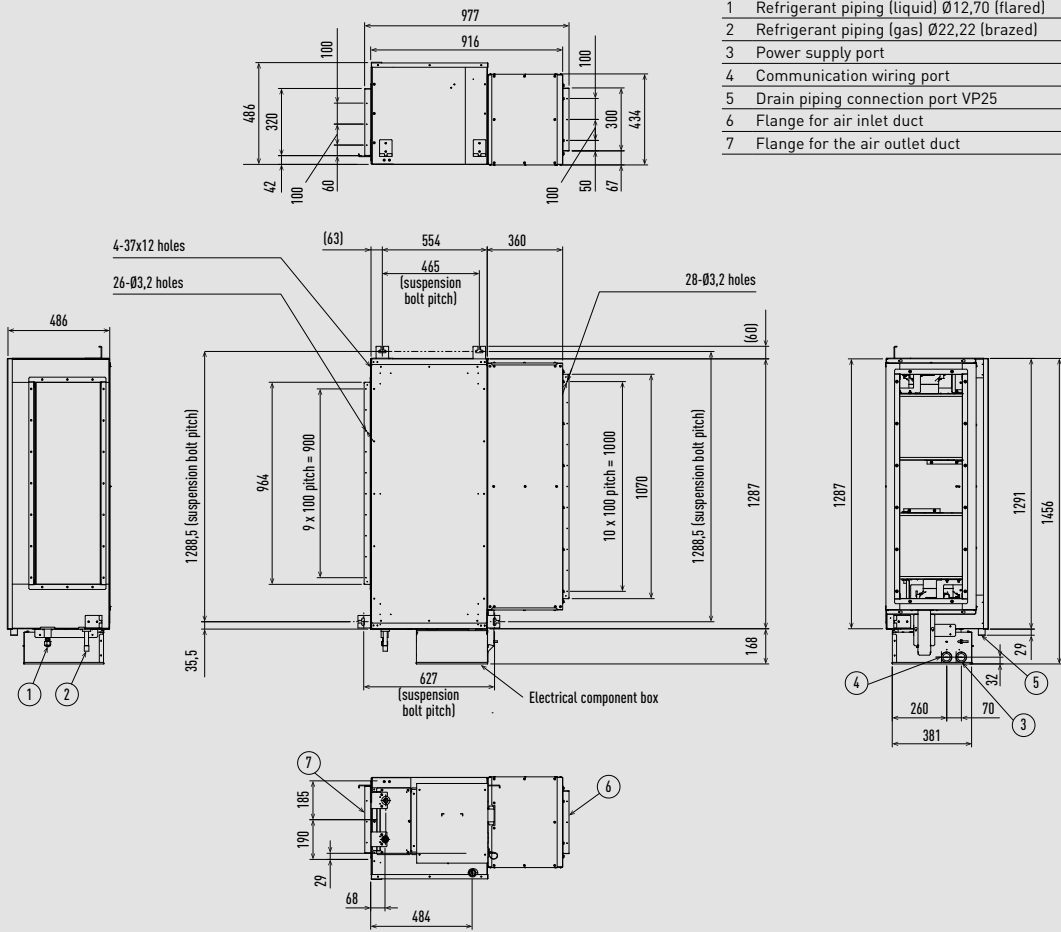

**Dimensions of suspension bolt pitch and unit.  
Required minimum space for installation and service**

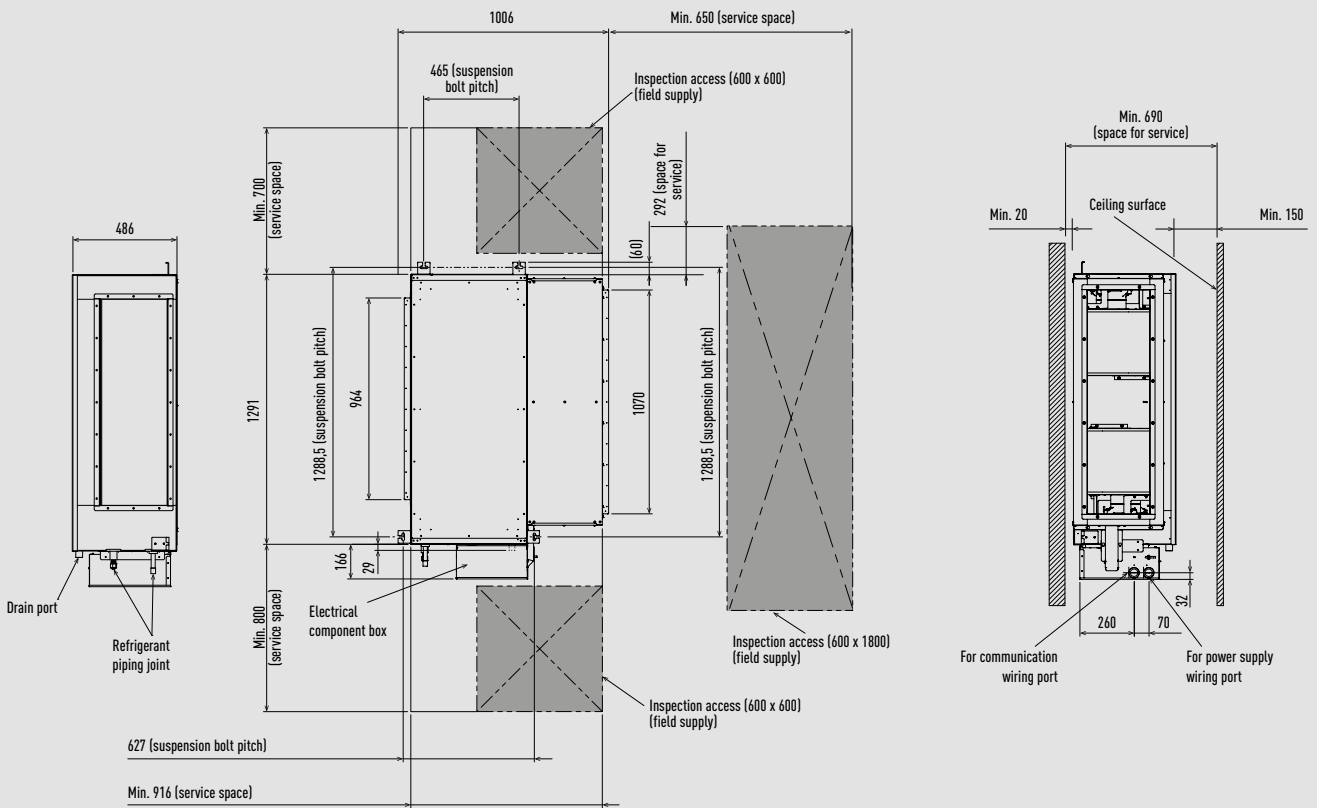

Unit: mm

Big PACi high static pressure hide-away 20,0-25,0 kW.

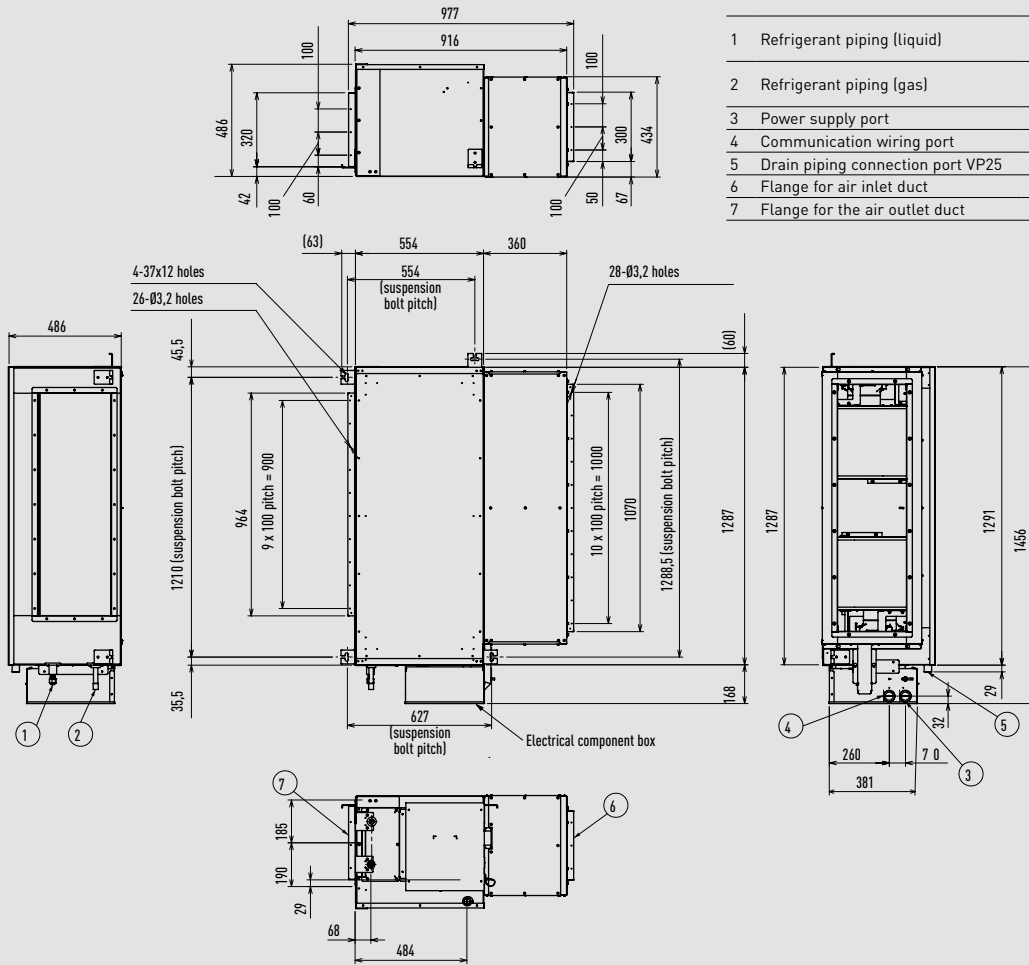

	S-200PE3E5B	S-250PE3E5B
1 Refrigerant piping (liquid)	Connection piping Ø12,70 > Ø9,52	Ø12,70 (flared)
2 Refrigerant piping (gas)	Connection piping Ø19,05 > Ø25,40	Ø19,05 (brazed)
3 Power supply port		
4 Communication wiring port		
5 Drain piping connection port VP25		
6 Flange for air inlet duct		
7 Flange for the air outlet duct		

Dimensions of suspension bolt pitch and unit.  
Required minimum space for installation and service

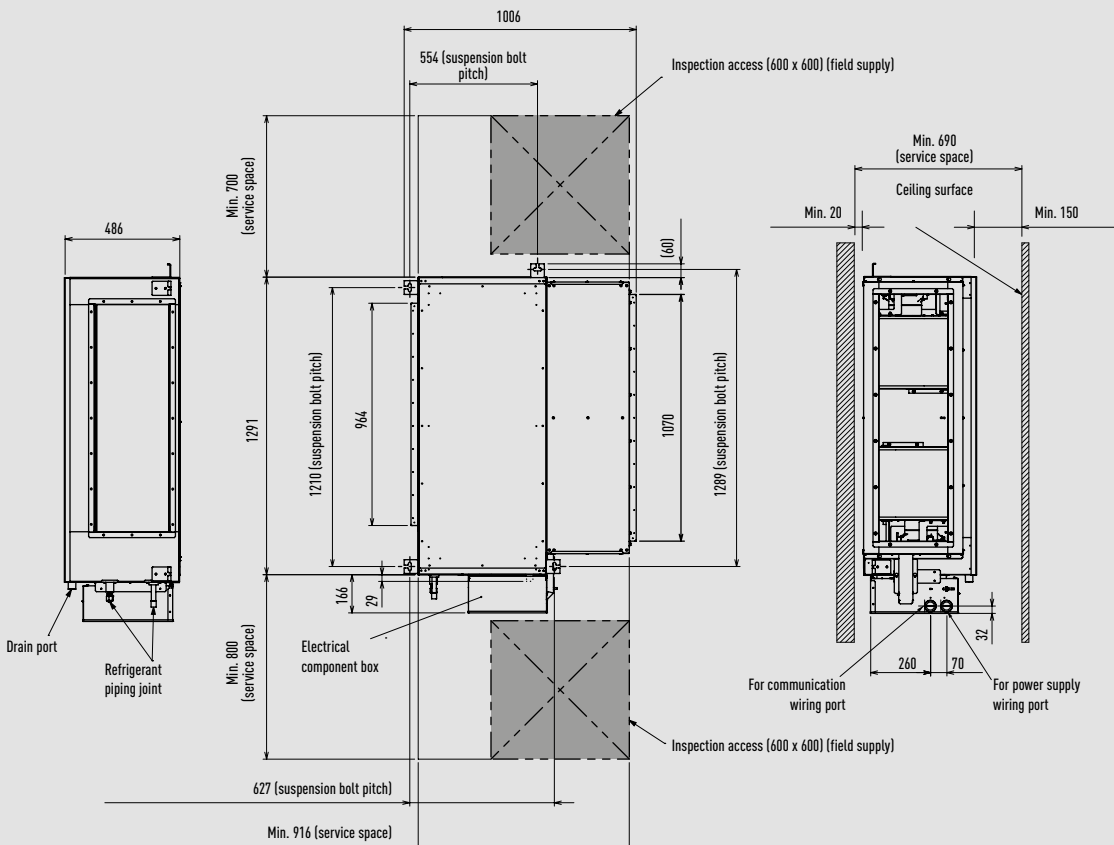

Unit: mm

Jet Air Stream - P-VTVF25MC5-PE / P-VTVF25NC5-PE / P-VTVF25PC5-PE.

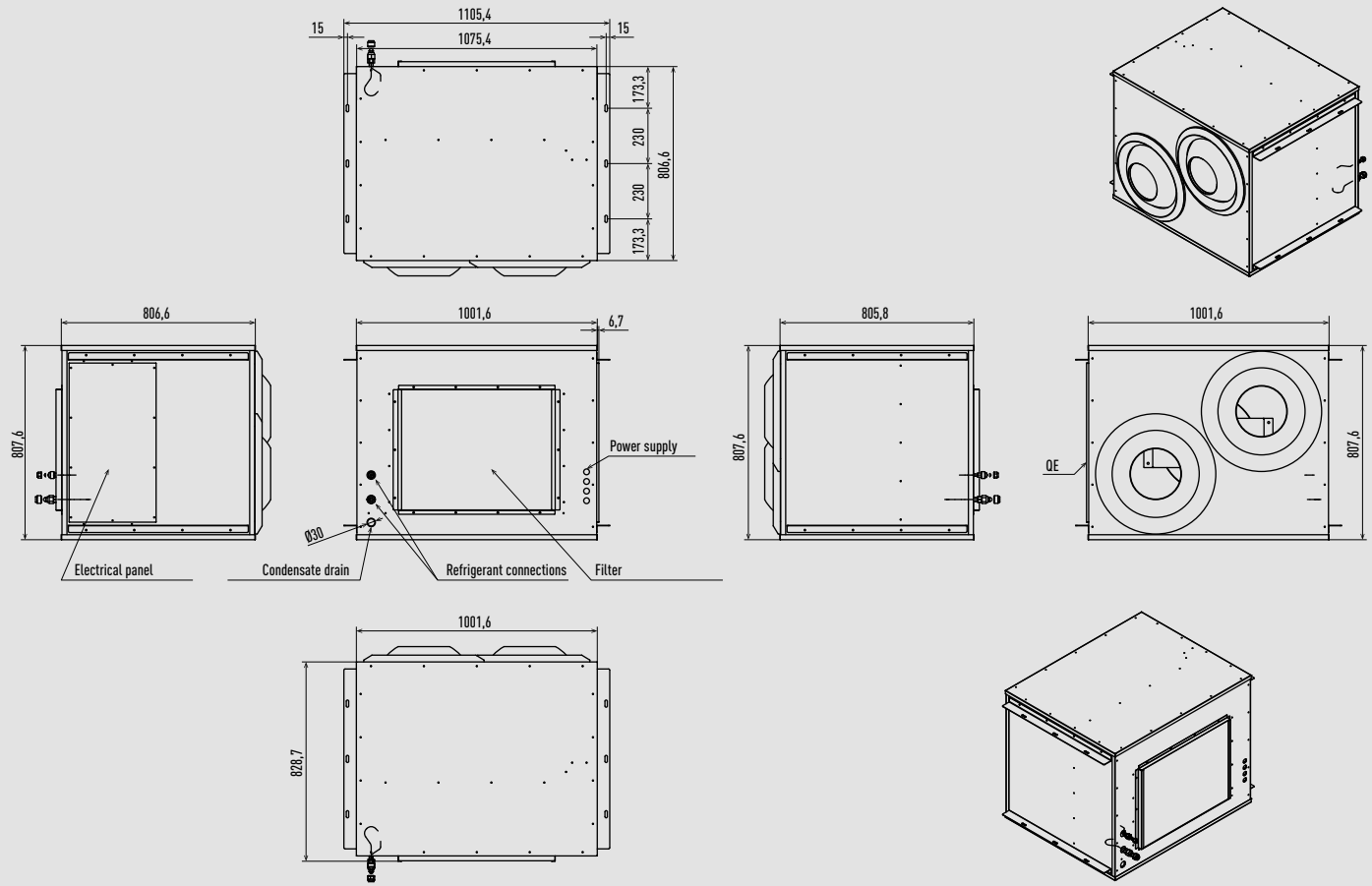

Unit: mm

Jet Air Stream - P-VTVF50MC5-PE / P-VTVF50NC5-PE / P-VTVF50PC5-PE.

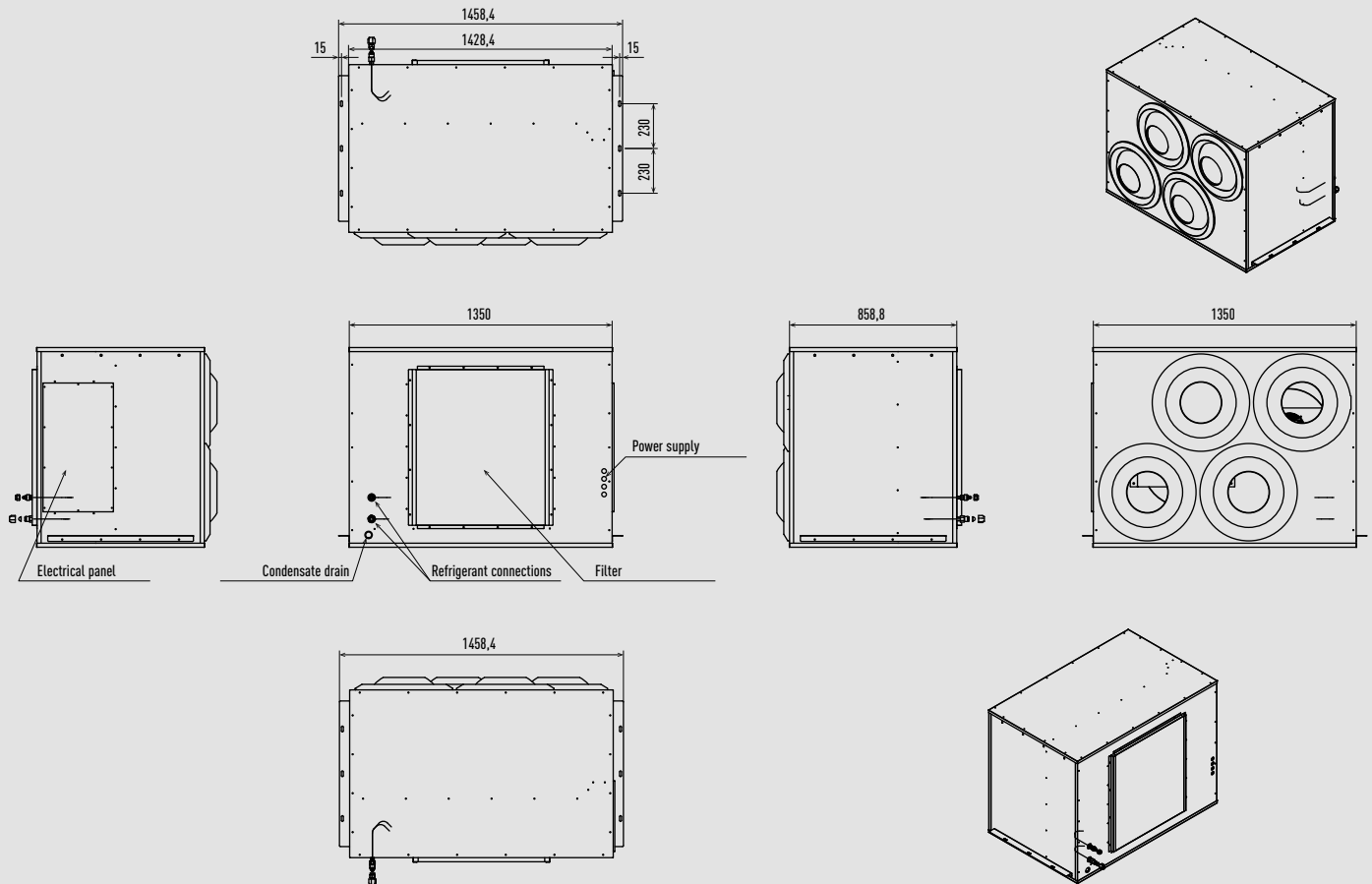

Unit: mm

PACi NX Series Elite outdoor units from 3,6 to 6,0 kW and Standard 6,0 and 7,1 kW.

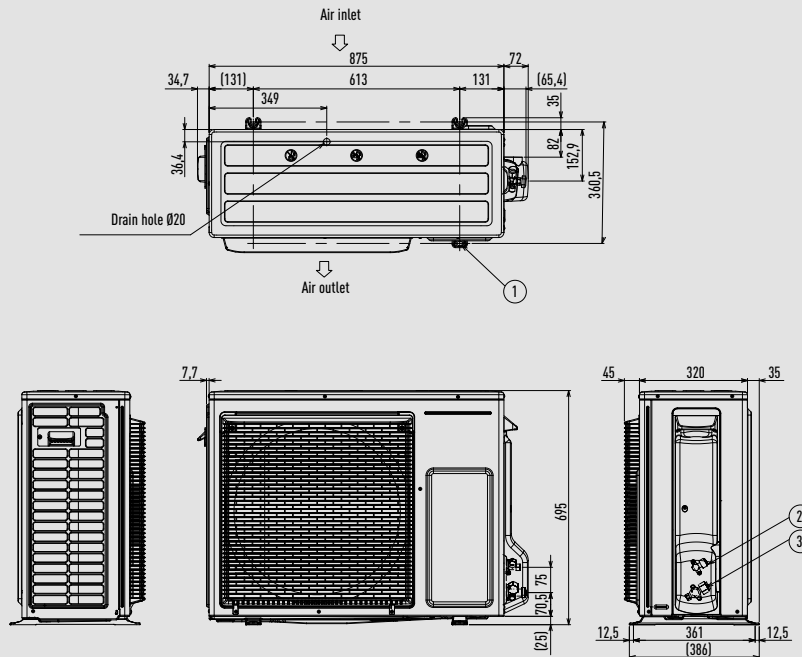

- 1 Mounting hole [4-R6,5], anchor bolt: M10
- 2 Refrigerant piping (liquid), Ø6,35 (flared)
- 3 Refrigerant piping (gas), Ø12,70 (flared). U-71PZ3E5, Ø15,88 (flared)

Unit: mm

PACi NX Series Elite outdoor units from 7,1 kW to 14,0 kW and Standard from 10,0 to 14,0 kW.

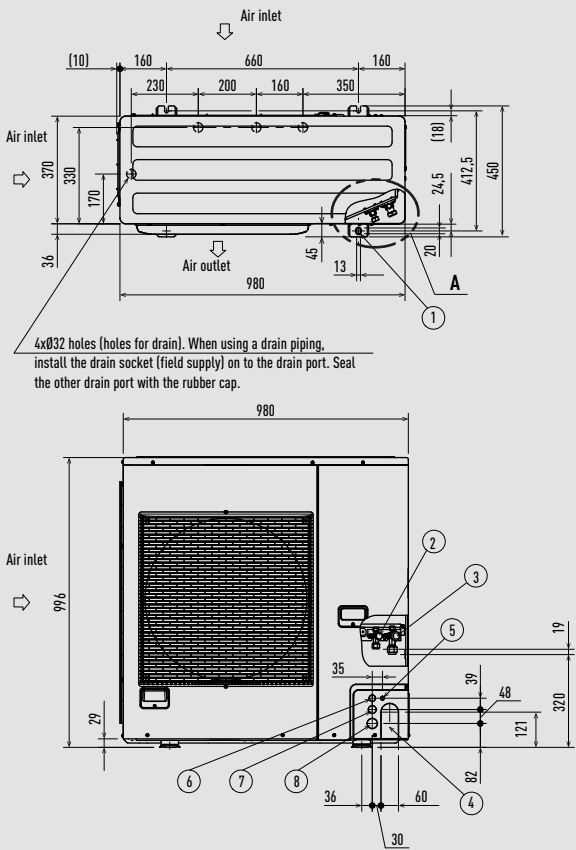

4xØ32 holes (holes for drain). When using a drain piping, install the drain socket (field supply) on to the drain port. Seal the other drain port with the rubber cap.

- 1 Mounting hole, anchor bolt: M10
- 2 Refrigerant piping (liquid), Ø9,52 (flared)
- 3 Refrigerant piping (gas), Ø15,88 (flared)
- 4 Refrigerant piping port
- 5 Electrical wiring port (Ø13)
- 6 Electrical wiring port (Ø22)
- 7 Electrical wiring port (Ø27)
- 8 Electrical wiring port (Ø35)

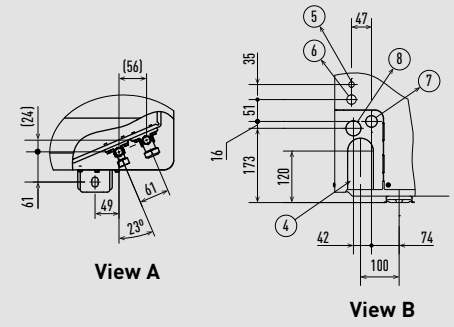

Unit: mm

PACi NX Series Standard outdoor units from 2,5 to 5,0 kW.

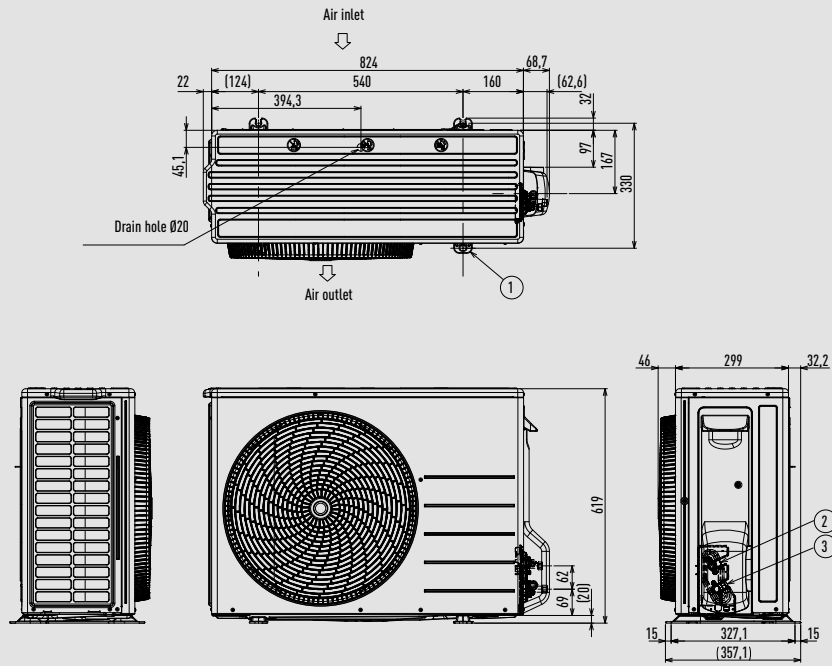

- 1 Mounting hole (4-R6,5), anchor bolt: M10
- 2 Refrigerant piping (liquid), Ø6,35 (flared)
- 3 Refrigerant piping (gas), Ø12,70 (flared)

Unit: mm

Big PACi NX outdoor units 20,0-25,0 kW.

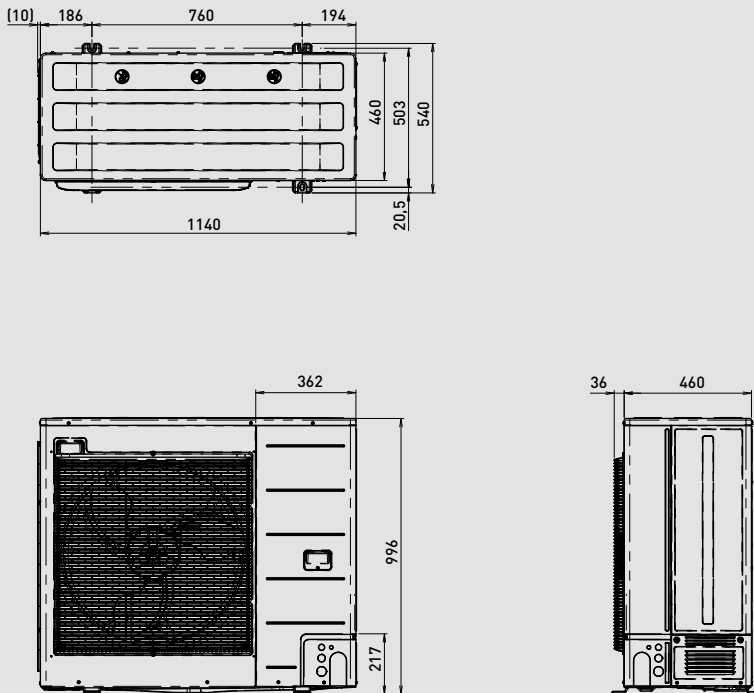

Unit: mm

Big PACi outdoor units 20,0-25,0 kW.

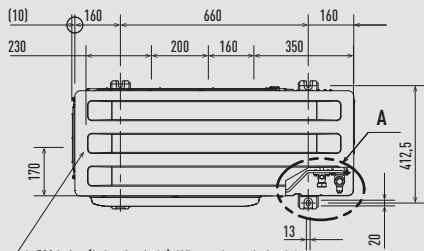

4xØ32 holes (holes for drain). When using a drain piping, install the drain socket (field supply) on to the drain port. Seat the other drain port with the rubber cap.

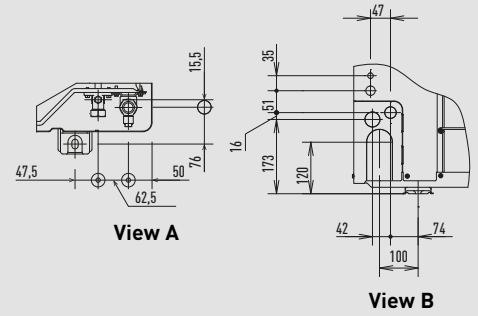
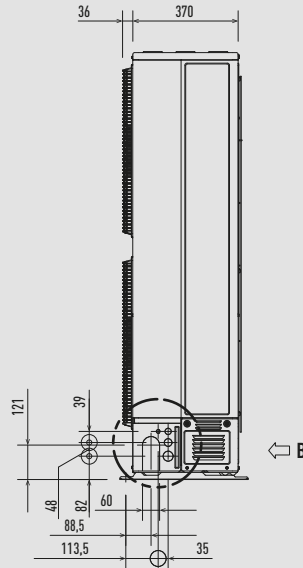
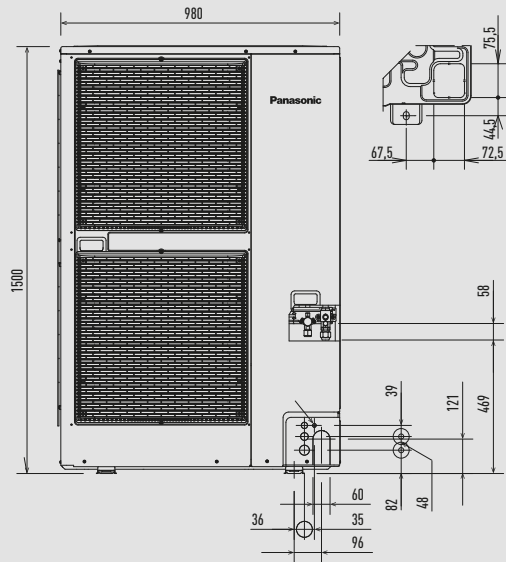

Unit: mm

PACi Water Heat Exchanger.

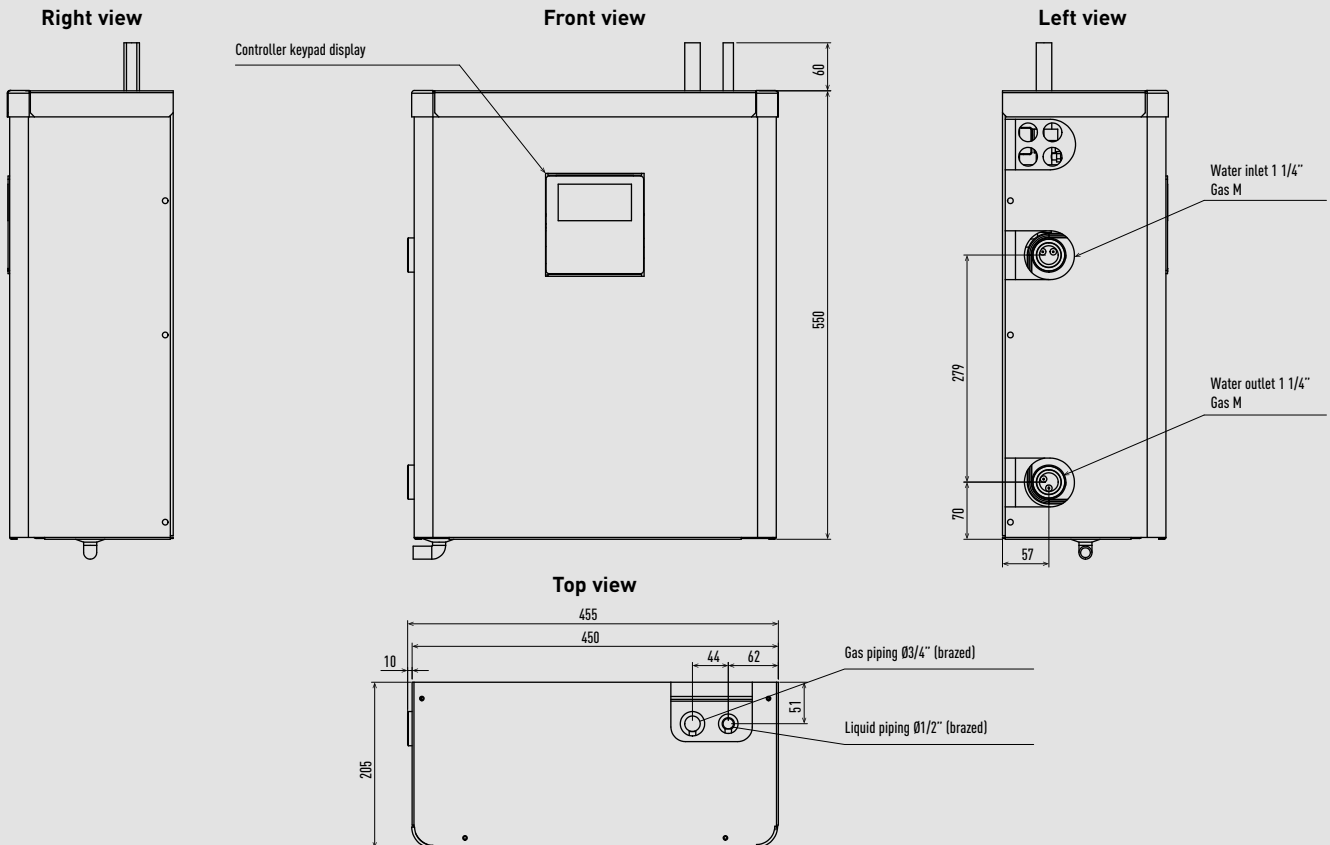

Unit: mm

Mini ECOi LZ2 Series from 4 to 6 HP.

Top view

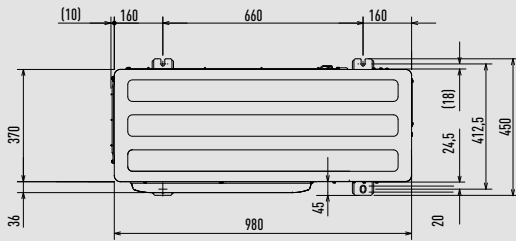

Front view

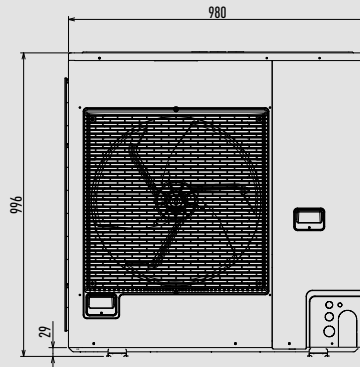

Side view

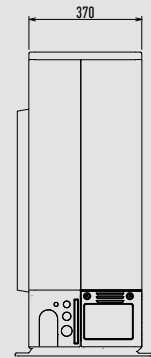

Unit: mm

Mini ECOi LZ2 Series 8 and 10 HP.

Top view

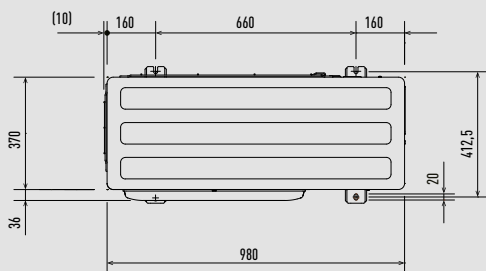

Front view

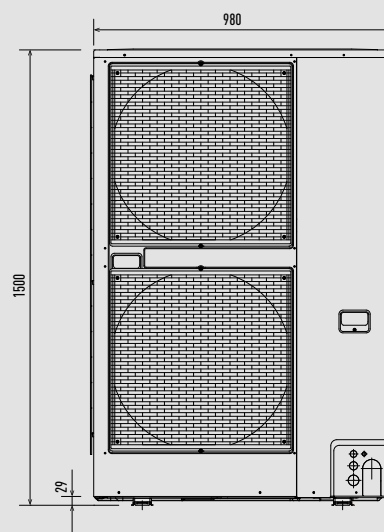

Side view

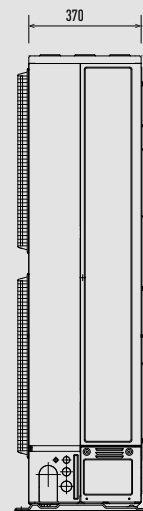

Unit: mm

Mini ECOi LE2 Series from 4 to 6 HP.

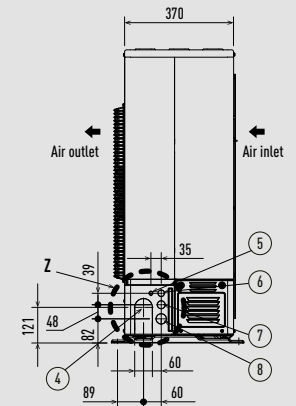
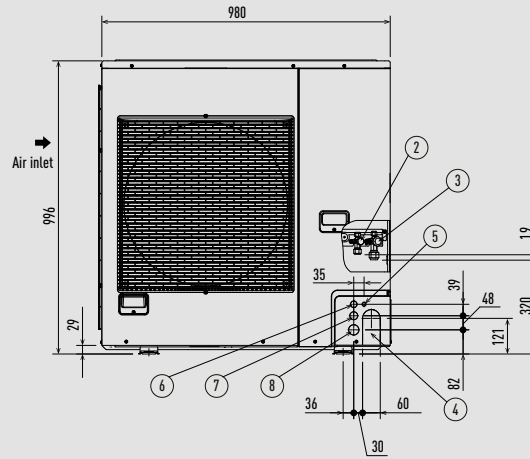
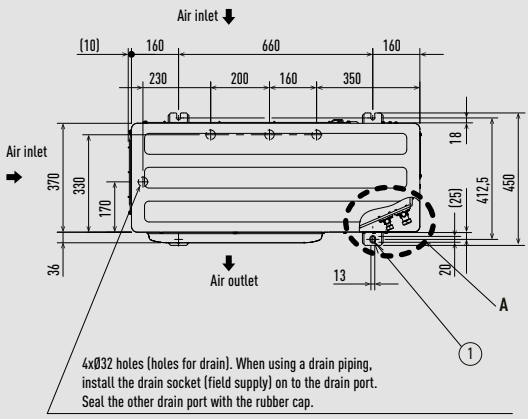

View A

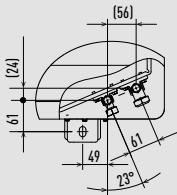

View Z

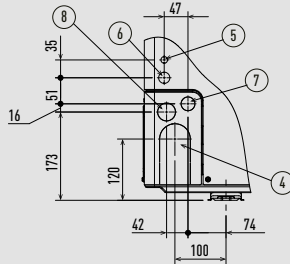

- 1 Mounting hole (4-R6,5), anchor bolt: M10
- 2 Refrigerant piping (liquid), Ø9,52 (flared)
- 3 Refrigerant piping (gas), Ø19,05 (flared)
- 4 Refrigerant piping port
- 5 Electrical wiring port (Ø13)
- 6 Electrical wiring port (Ø22)
- 7 Electrical wiring port (Ø27)
- 8 Electrical wiring port (Ø35)

Unit: mm

Mini ECOi LE1 Series 8 and 10 HP.

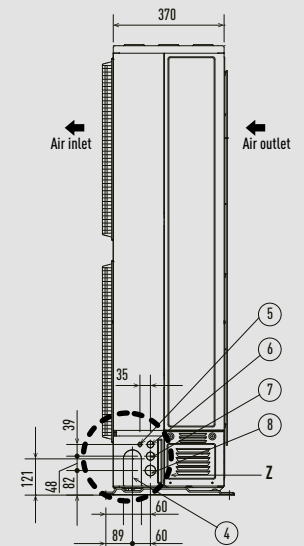
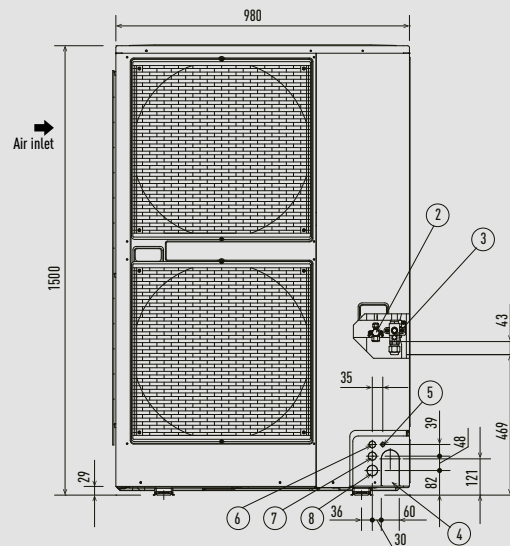
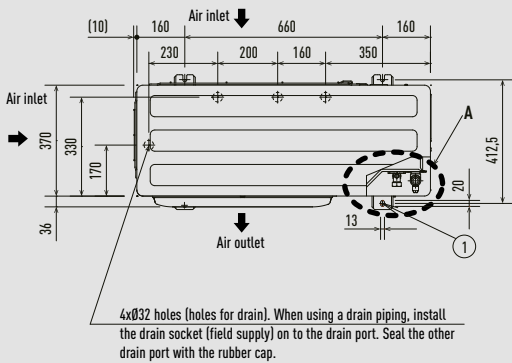

View A

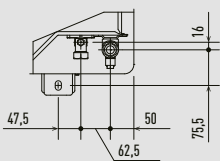

View Z

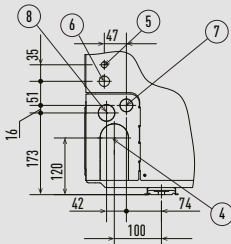

- 1 Mounting hole (4-R6,5), anchor bolt: M10
- 2 Refrigerant piping (liquid), Ø9,52 (flared)
- 3 Refrigerant piping (gas), Ø19,05 (flared)
- 4 Refrigerant piping port
- 5 Electrical wiring port (Ø13)
- 6 Electrical wiring port (Ø22)
- 7 Electrical wiring port (Ø27)
- 8 Electrical wiring port (Ø35)

The piping of the gas main has a diameter of Ø22,22, but the connection to the service valve of the outdoor unit has a diameter of Ø19,05, so a flare has to be used. Consequently, be sure to use the enclosed joint piping B and joint piping A in making connections (brazed).

Unit: mm

2-Pipe ECOi EX ME2 Series 8 and 10 HP.

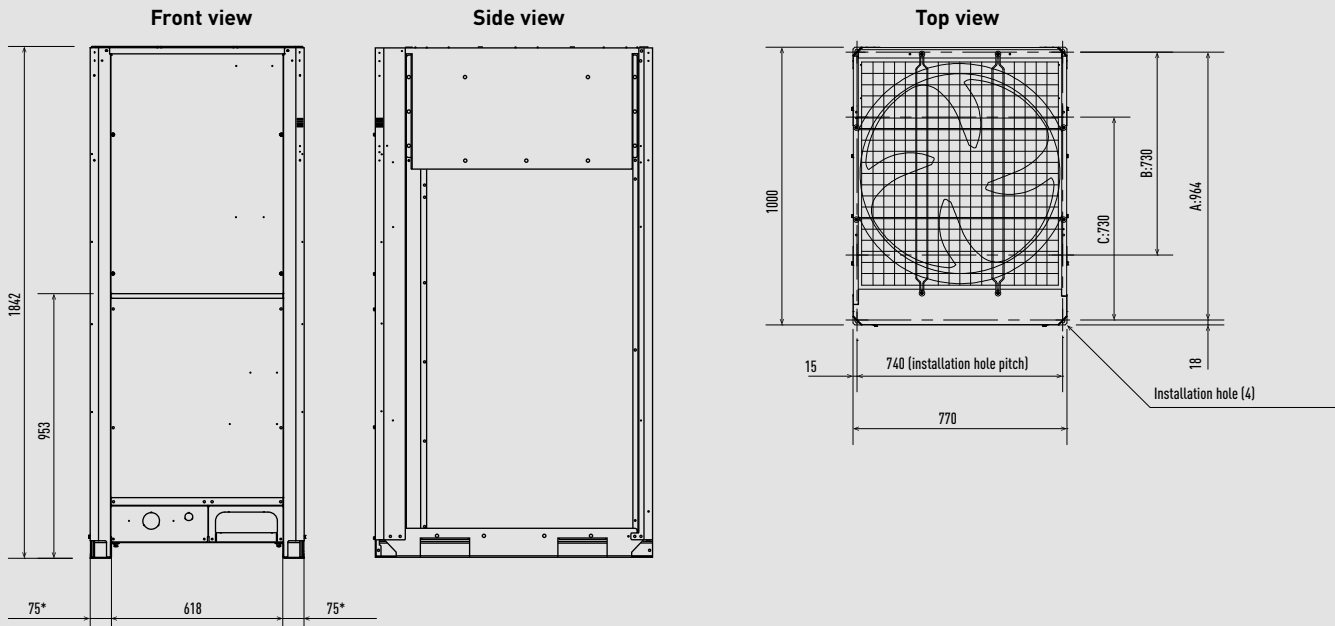

According to the installation site, you may choose the setting position in the depth direction of the anchor bolt from A, B or C.

- A: 964 (installation hole pitch). The piping is routed out from the front.
- B: 730 (installation hole pitch)\*. The piping is routed out from the bottom.
- C: 730 (installation hole pitch).

\* Installation fixing bracket. Installation side.

Unit: mm

2-Pipe ECOi EX ME2 Series 12, 14 and 16 HP / 3-Pipe ECOi EX MF3 Series.

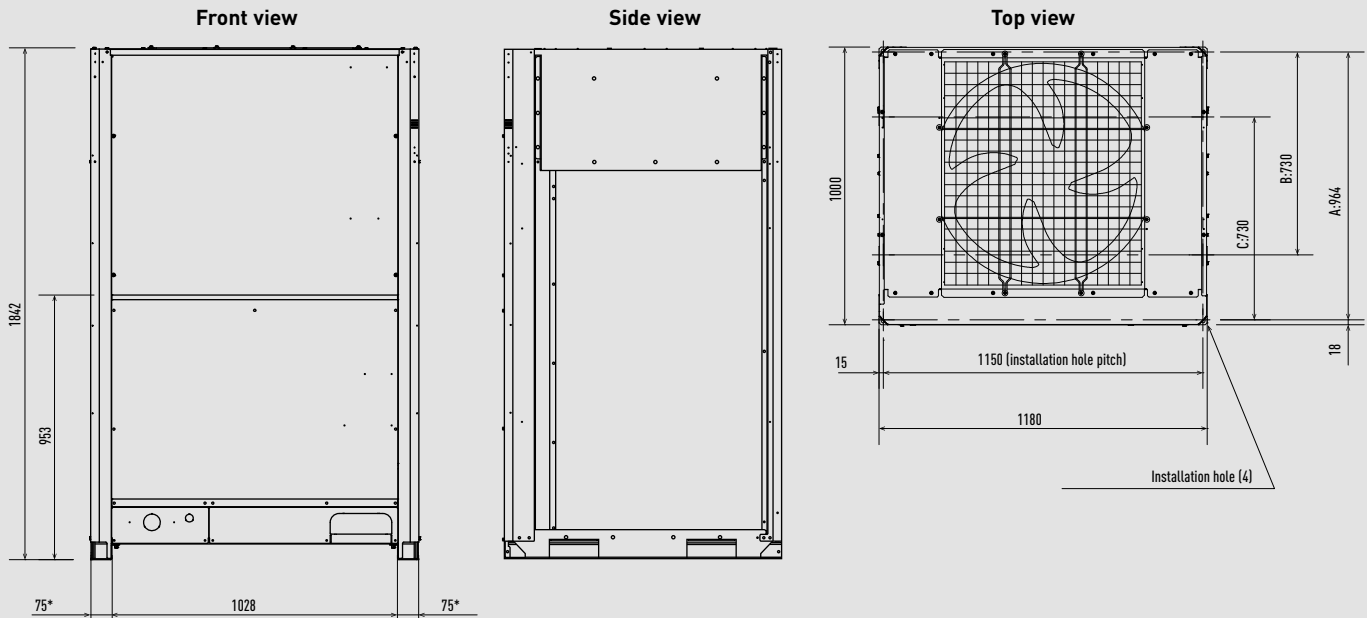

According to the installation site, you may choose the setting position in the depth direction of the anchor bolt from A, B or C.

- A: 964 (installation hole pitch). The piping is routed out from the front.
- B: 730 (installation hole pitch)\*. The piping is routed out from the bottom.
- C: 730 (installation hole pitch).

\* Installation fixing bracket. Installation side.

Unit: mm

2-Pipe ECOi EX ME2 Series 18 and 20 HP.

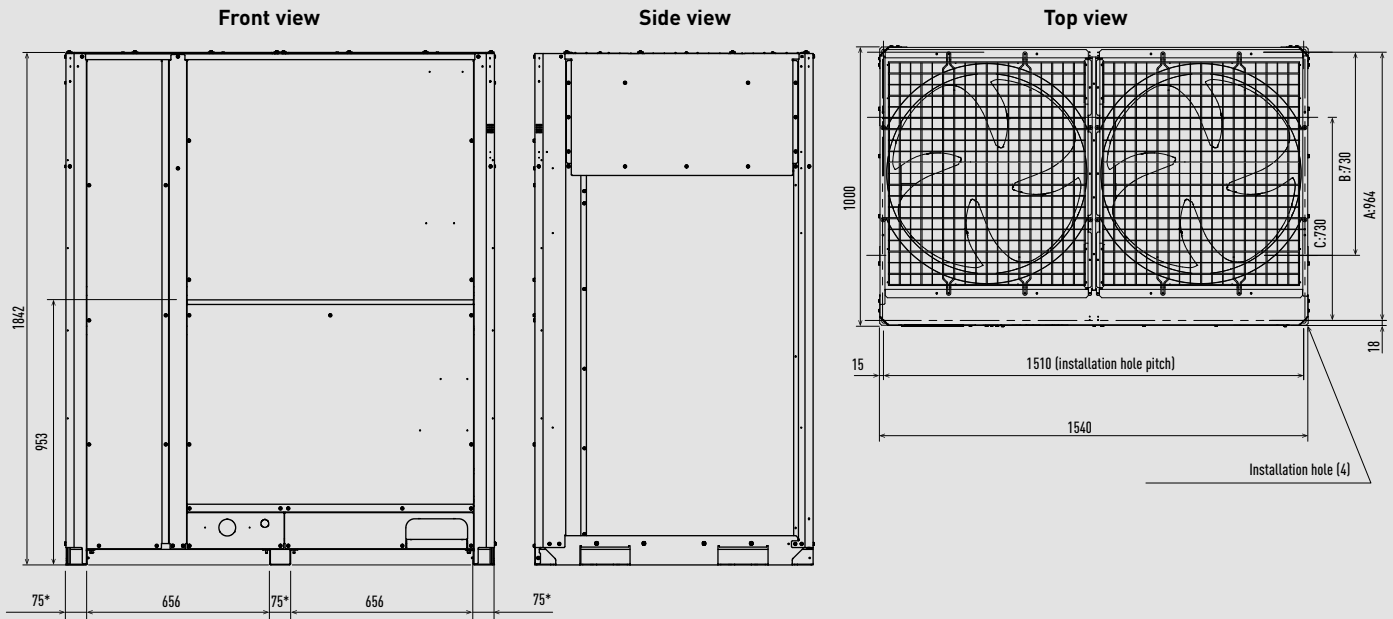

According to the installation site, you may choose the setting position in the depth direction of the anchor bolt from A, B or C.

A: 964 (installation hole pitch). The piping is routed out from the front.  
 B: 730 (installation hole pitch)\*. The piping is routed out from the bottom.  
 C: 730 (installation hole pitch).

\* Installation fixing bracket. Installation side.

Unit: mm

2-Pipe ECO G GE3 Series 16 and 20 HP.

Type	16 HP	20 HP
1 Refrigerant piping (gas)		Ø28,58
2 Refrigerant piping (liquid)	Ø12,70	Ø15,88
3 Exhaust gas drain port	Hose outer diameter: Ø25 (accessory)	
4 Electrical power supply port		Ø28
5 Inter-unit cable port		Ø28
6 Fuel gas port		R3/4
7 Condensation drain opening		Ø20
8 Rain and condensation outlet		

Type	16 HP	20 HP
9 Engine re Exhaust outlet		
10 Suspension holes 4-Ø20x30		
11 Anchor holes 4-22x30		
12 Segmented display		
13 Coolant intake (top)		
14 Air inlet		
15 Coolant level		
16 Hot water inlet		Rp3/4
17 Hot water outlet		Rp3/4

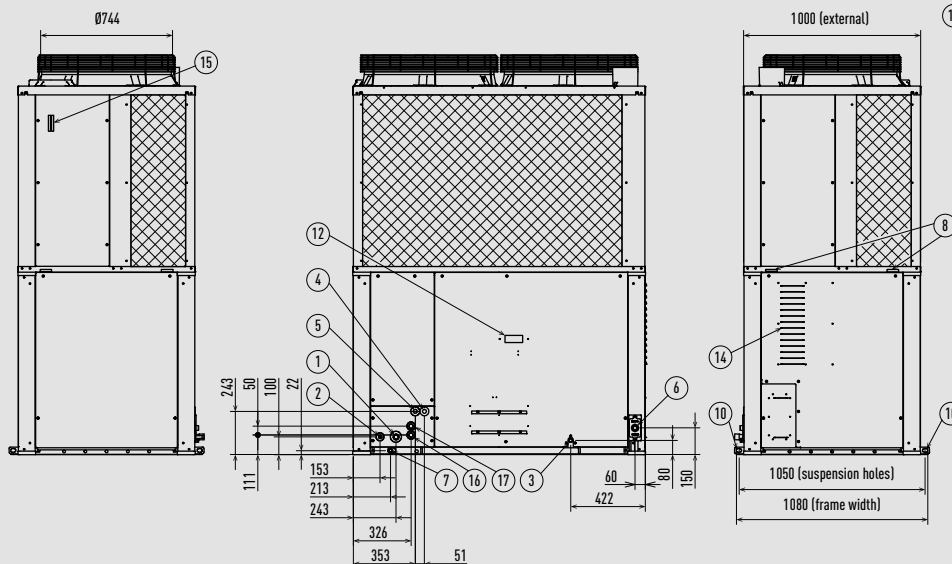
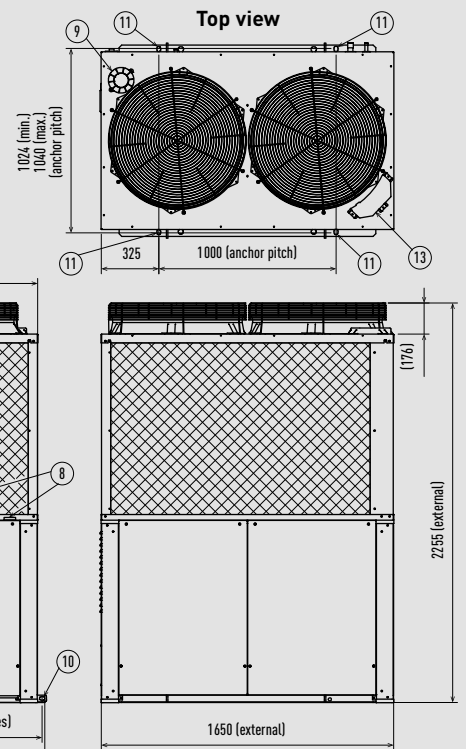

Right view

Rear view

Left view

Front view

Unit: mm

### 2-Pipe ECO G GE3 Series 25 and 30 HP.

Type	25 HP	30 HP
1 Refrigerant piping (gas)	Ø28,58	Ø31,75
2 Refrigerant piping (liquid)	Ø15,88	Ø19,05
3 Exhaust gas drain port	Hose outer diameter: Ø25 (accessory)	
4 Electrical power supply port	Ø28	
5 Inter-unit cable port	Ø28	
6 Fuel gas port	R3/4	
7 Condensation drain opening	Ø20	
8 Rain and condensation outlet		

Type	25 HP	30 HP
9 Engine exhaust outlet		
10 Suspension holes 4-Ø20x30		
11 Anchor holes 4-22x30		
12 Segmented display		
13 Coolant intake (top)		
14 Air inlet		
15 Coolant level		
16 Hot water inlet	Rp3/4	
17 Hot water outlet	Rp3/4	

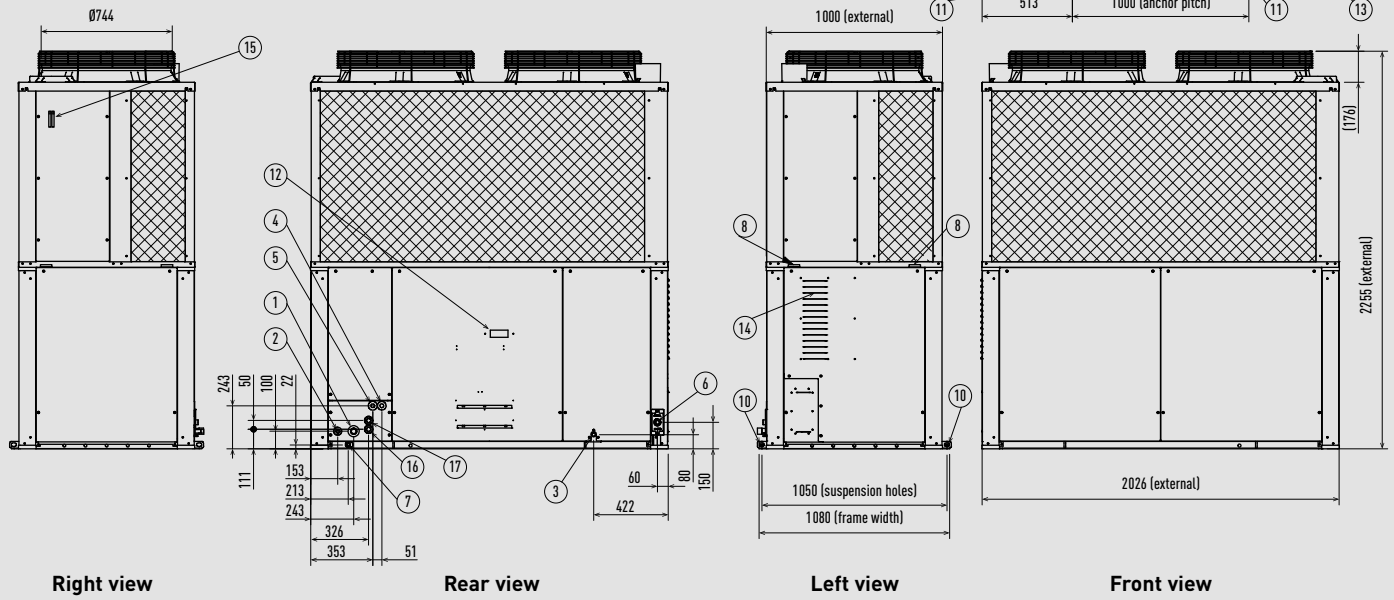

Unit: mm

### 3-Pipe ECO G GF3 Series 16 and 20 HP.

Type	16HP	20HP
1 Suction refrigerant piping (gas)	Ø28,58	
2 Discharge refrigerant piping (gas)	Ø22,22	Ø25,40
3 Refrigerant piping (liquid)	Ø19,05	
4 Exhaust gas drain port	Hose outer diameter: Ø25 (accessory)	
5 Electrical power supply port	Ø28	
6 Inter-unit cable port	Ø28	
7 Fuel gas port	R3/4	
8 Condensation drain opening	Ø20	

Type	16HP	20HP
9 Rain and condensation outlet		
10 Engine exhaust outlet		
11 Suspension holes 4-Ø20x30		
12 Anchor holes 4-22x30		
13 Segmented display		
14 Coolant intake (top)		
15 Air inlet		
16 Coolant level		
17 Hot water inlet	Rp3/4	
18 Hot water outlet	Rp3/4	

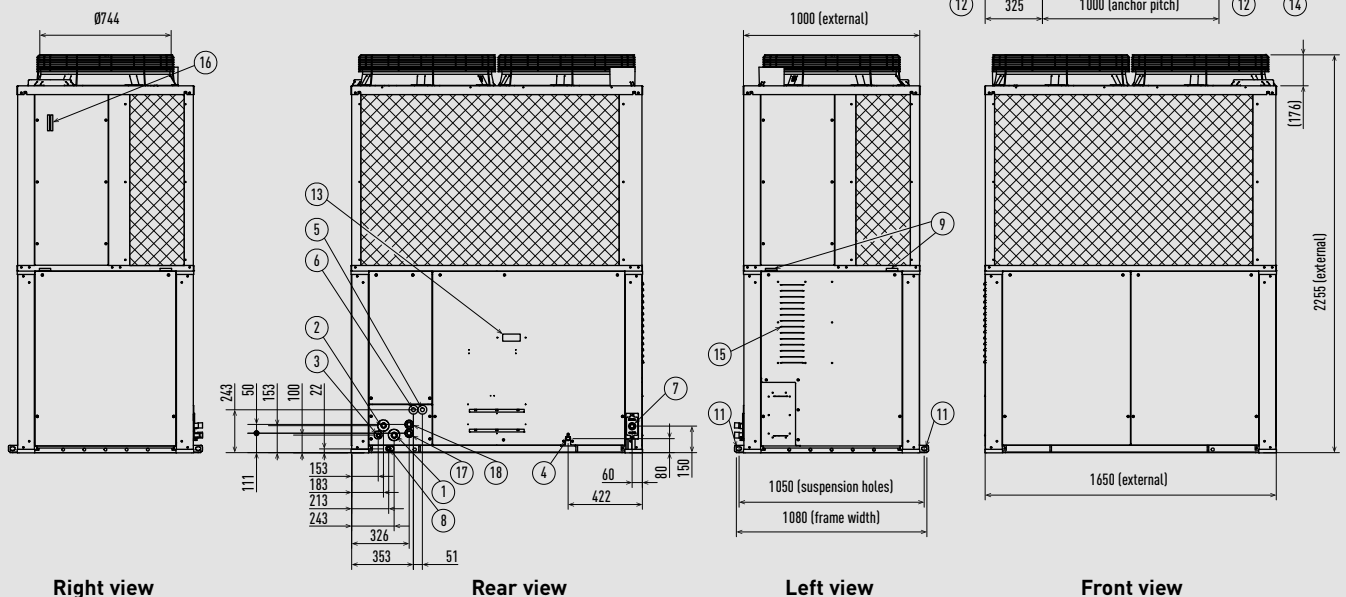

Unit: mm



## 2-Pipe Hybrid EHP - U-10MES2E8.

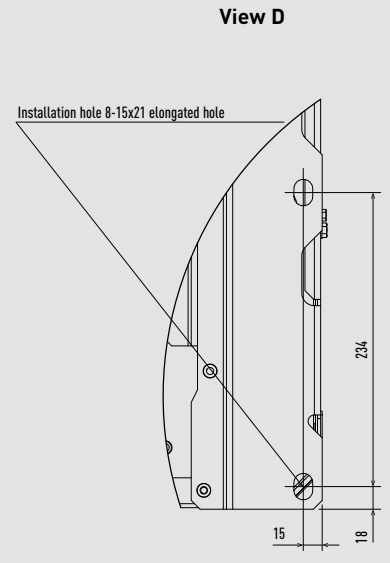
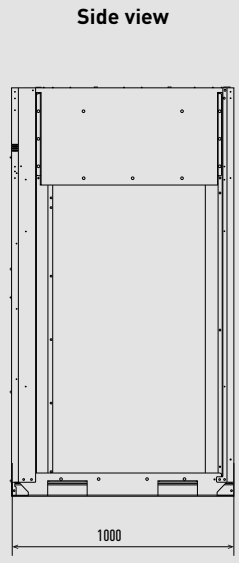
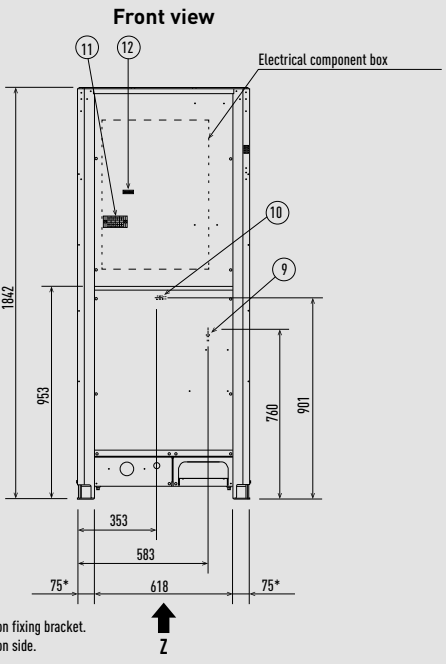
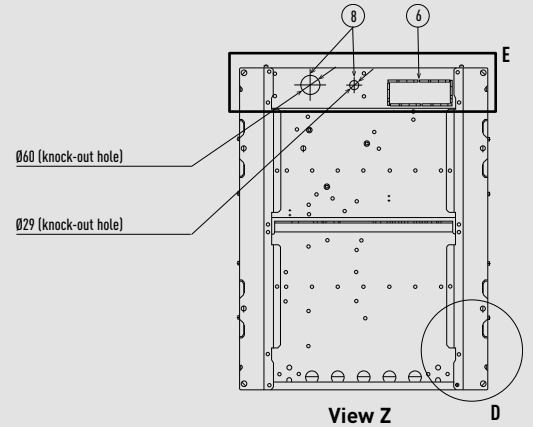
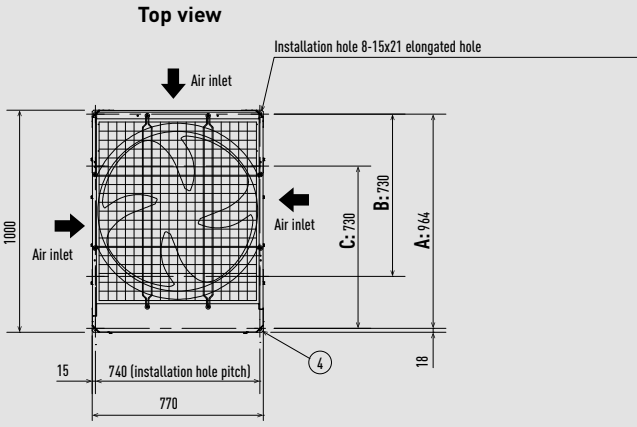

\* Installation fixing bracket. Installation side.

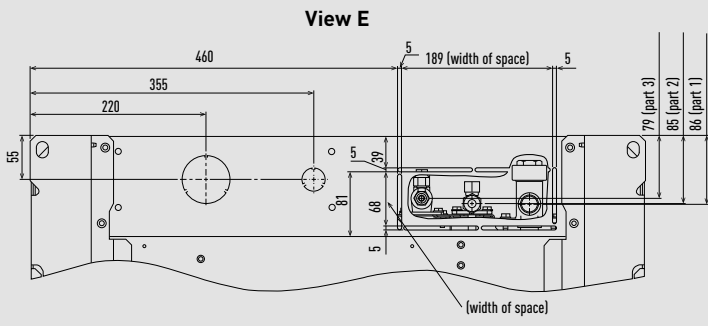

### Position of refrigerant piping connection

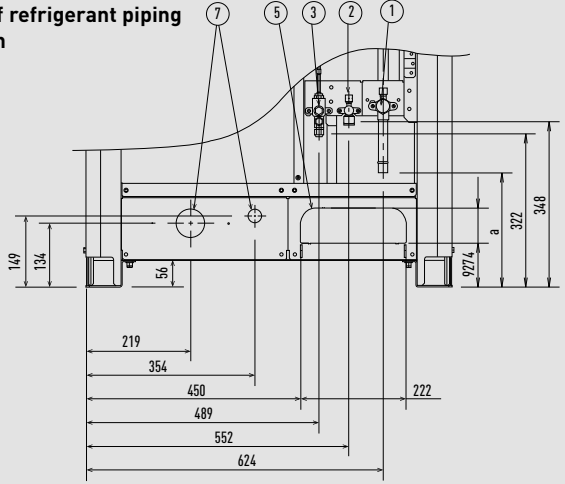

- 1 Refrigerant piping (gas), Ø22,22 (brazed)
- 2 Refrigerant piping (liquid), Ø9,52 (flared)
- 3 Refrigerant piping (balance), Ø6,35 (flared)
- 4 Installation hole [8-15x21 elongated holes], anchor bolts M12 or larger
- 5 Refrigerant piping port (front: knock-out hole)
- 6 Refrigerant piping port (bottom: slit hole)
- 7 Electrical wiring port (front: Ø60, Ø29 knock-out hole - for conduit connection)
- 8 Electrical wiring port (bottom: Ø60, Ø29 knock-out hole - for conduit connection)
- 9 Pressure outlet port (for high pressure: Ø7,94 Schrader type connection)
- 10 Pressure outlet port (for low pressure: Ø7,94 Schrader type connection)
- 11 Terminal plate
- 12 Terminal plate for inter-unit control wiring and/or inter-outdoor unit control wiring

According to the installation site, you may choose the setting position in the depth direction of the anchor bolt from A, B or C.

A: 964 (installation hole pitch). The piping is routed out from the front.  
 B: 730 (installation hole pitch)\*. The piping is routed out from the bottom.  
 C: 730 (installation hole pitch).

\* Installation fixing bracket. Installation side.

### 2-Pipe Hybrid GHP - U-20GES3E5.

1 Refrigerant piping (gas), Ø28,58	10 Engine exhaust outlet
2 Refrigerant piping (liquid), Ø15,88	11 Suspension holes 4-Ø20x30
3 Knock-out hole. Refrigerant piping (balance)	12 Anchor holes 4-22x30
4 Exhaust gas drain port. Hose outer diameter: Ø25 (accessory)	13 7 segmented display
5 Electrical power supply port, Ø28	14 Coolant intake (top)
6 Inter-unit cable port, Ø28	15 Air inlet
7 Fuel gas port, R3/4	16 Coolant level
8 Condensation drain opening, Ø20	17 Hot water inlet, Rp3/4
9 Rain and condensation outlet	18 Hot water outlet, Rp3/4

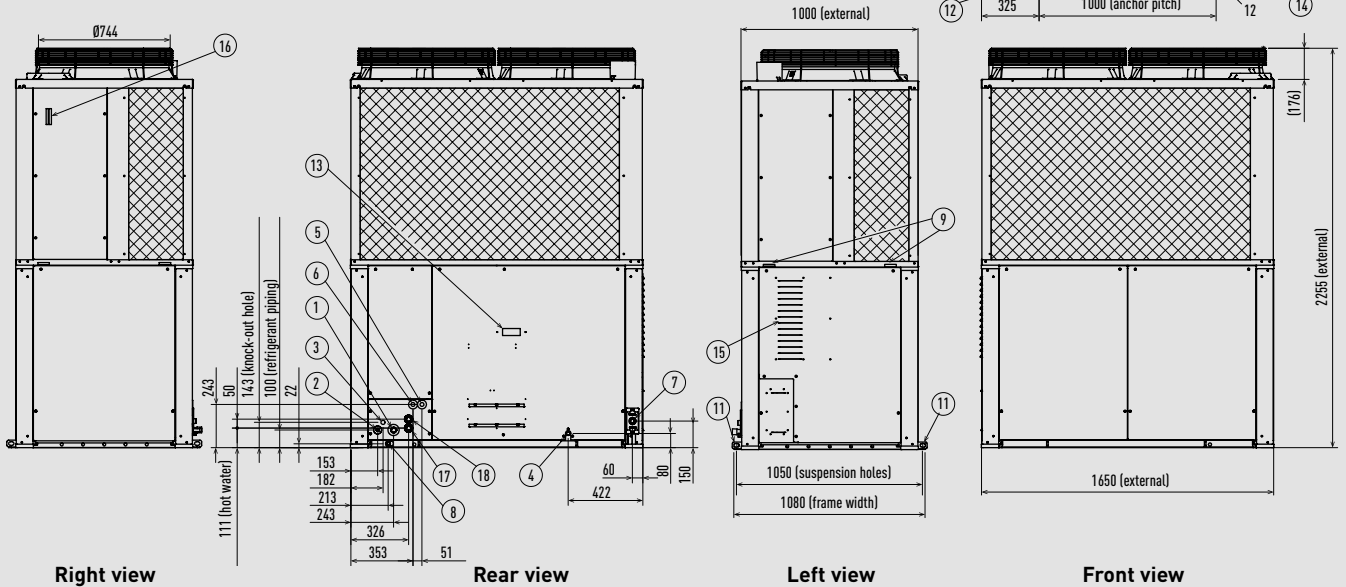

Unit: mm

### Water heat exchanger for chilled and hot water production.

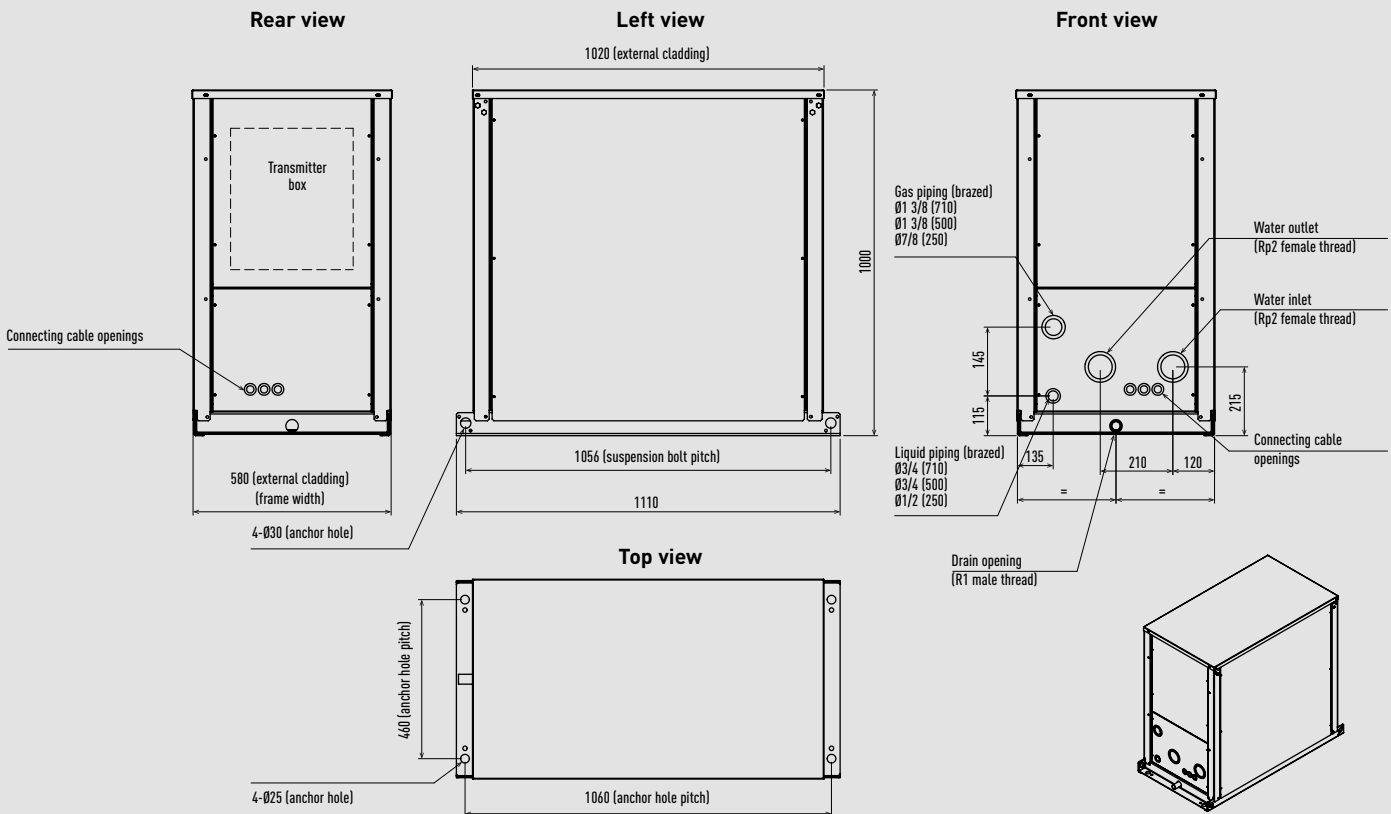

Unit: mm

U2 type 4 way 90x90 cassette.

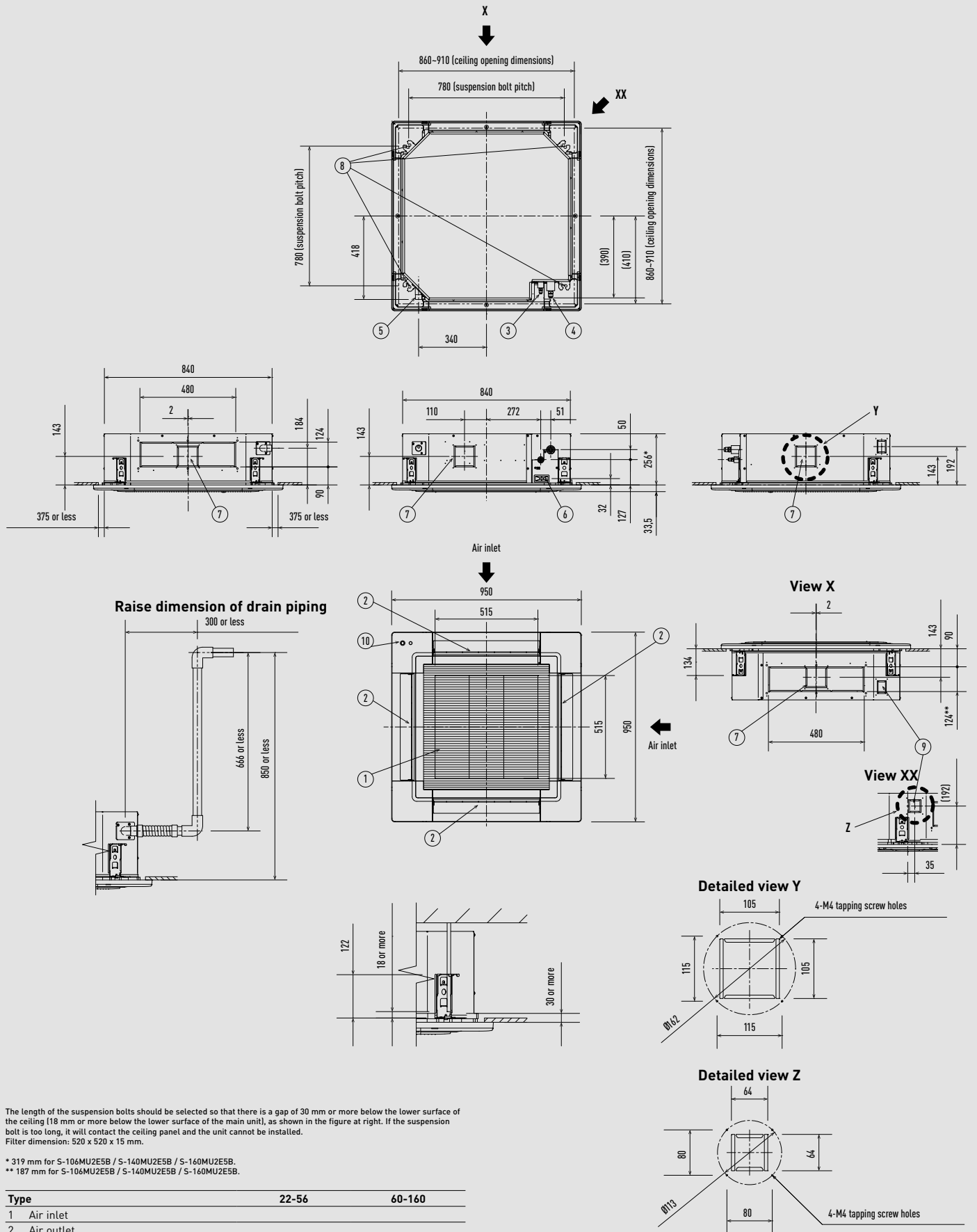

The length of the suspension bolts should be selected so that there is a gap of 30 mm or more below the lower surface of the ceiling (18 mm or more below the lower surface of the main unit), as shown in the figure at right. If the suspension bolt is too long, it will contact the ceiling panel and the unit cannot be installed.  
Filter dimension: 520 x 520 x 15 mm.

\* 319 mm for S-106MU2E5B / S-140MU2E5B / S-160MU2E5B.  
\*\* 187 mm for S-106MU2E5B / S-140MU2E5B / S-160MU2E5B.

Type	22-56	60-160
1 Air inlet		
2 Air outlet		
3 Refrigerant piping (liquid)	$\varnothing 6,35$ (flared)	$\varnothing 9,52$ (flared)
4 Refrigerant piping (gas)	$\varnothing 12,70$ (flared)	$\varnothing 15,88$ (flared)
5 Drain piping connection port VP25	Outer diameter 32 mm	
6 Power supply port		
7 Suspension bolt hole	4-12x30 elongated hole	
8 Fresh air inlet duct connection port	$\varnothing 100$ <sup>1)</sup>	
9 Suspension bolt hole	4-12x30 elongated hole	
10 Econavi sensor [only CZ-KPU3A]		

1) Necessary to attach duct connecting flange (field supplied).

Unit: mm

Y3 type 4 way 60x60 cassette.

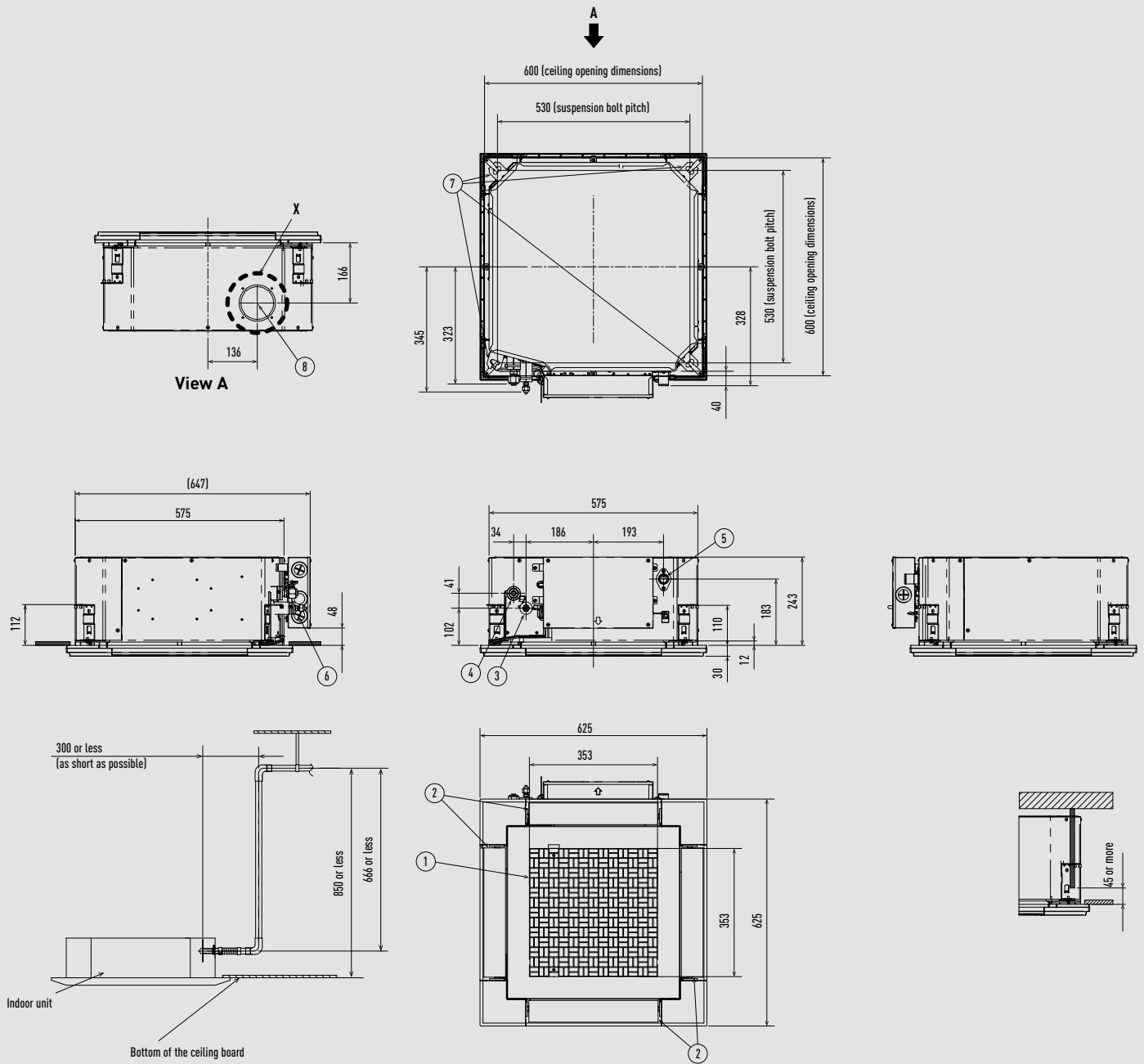

\* Length of supplied drain piping= 250 mm.

1	Air inlet	
2	Air outlet	
3	Refrigerant piping (liquid)	Ø6,35 (flared)
4	Refrigerant piping (gas)	Ø12,70 (flared)
5	Drain piping connection port VP20	
6	Power supply port	
7	Suspension bolt hole [4-11x26 slot]	
8	Fresh air inlet duct connection port (Ø100) <sup>1)</sup>	

1) Necessary to attach duct connecting flange (field supply).

Filter dimension: 362 x 362 x 15 mm.

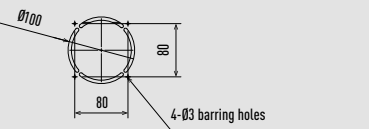

Detailed view X

L1 type 2 way cassette.

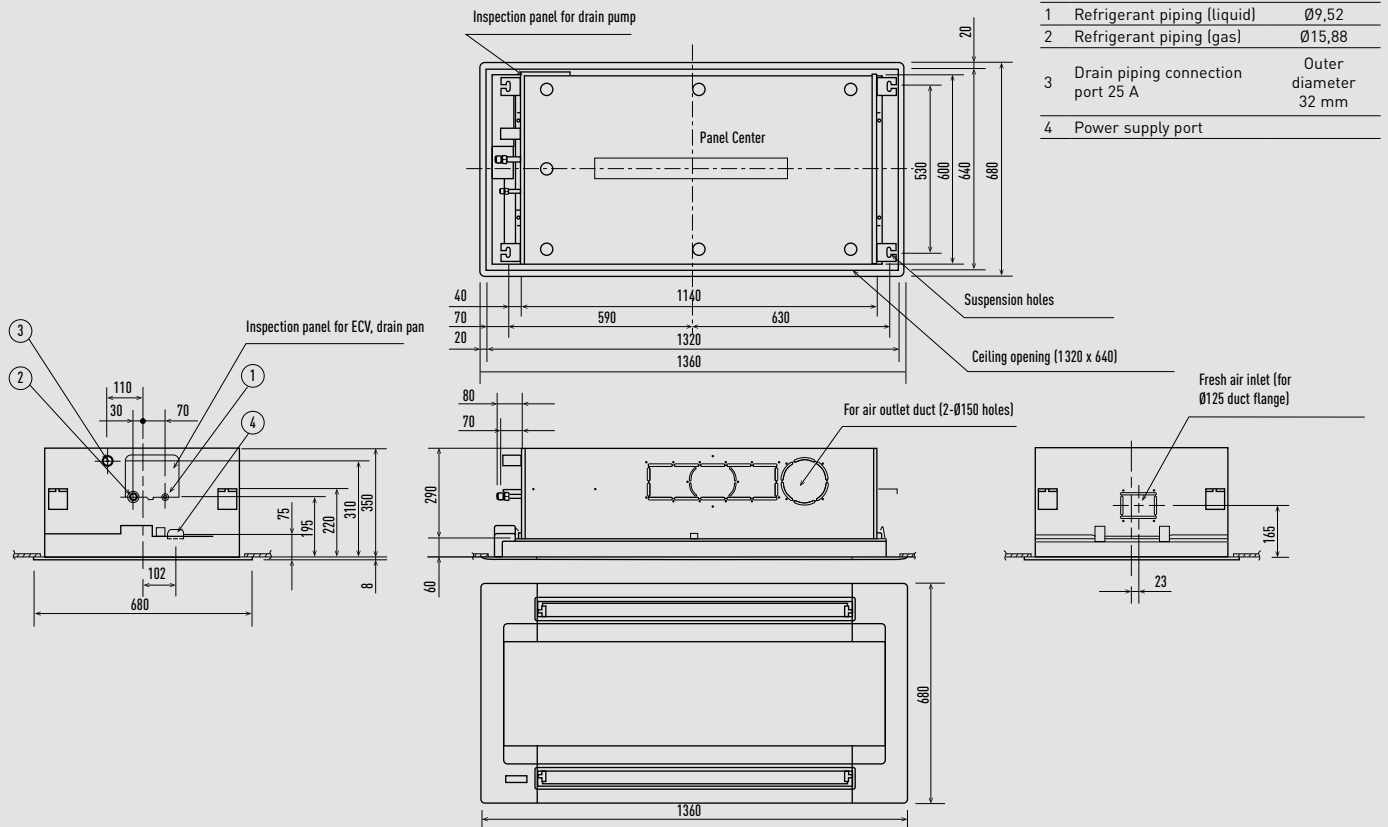

Unit: mm

D1 type 1 way cassette.

	28-56	73
1	Air inlet	
2	Air outlet	
3	Ø6,35 (flared)	Ø9,52 (flared)
4	Ø12,70 (flared)	Ø15,88 (flared)
5	Drain piping connection port VP25	Outer diameter 32 mm
6	Power supply port	
7	Air outlet duct connection port (for descending ceiling)	
8	Fresh air inlet duct connection port Ø100	
9	Wireless remote controller receiver installation location	
10	Suspension bolt hole 4-12x30 mm	

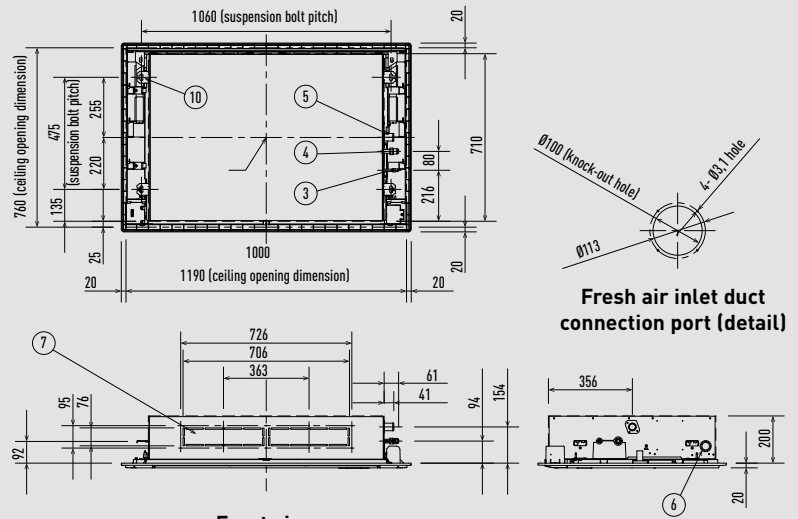

Space necessary for installation

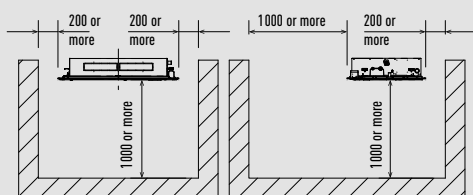

Front view

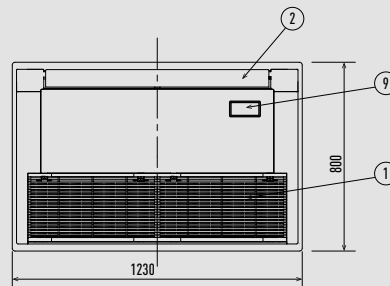

Unit: mm

F3 type variable static pressure adaptive duct.

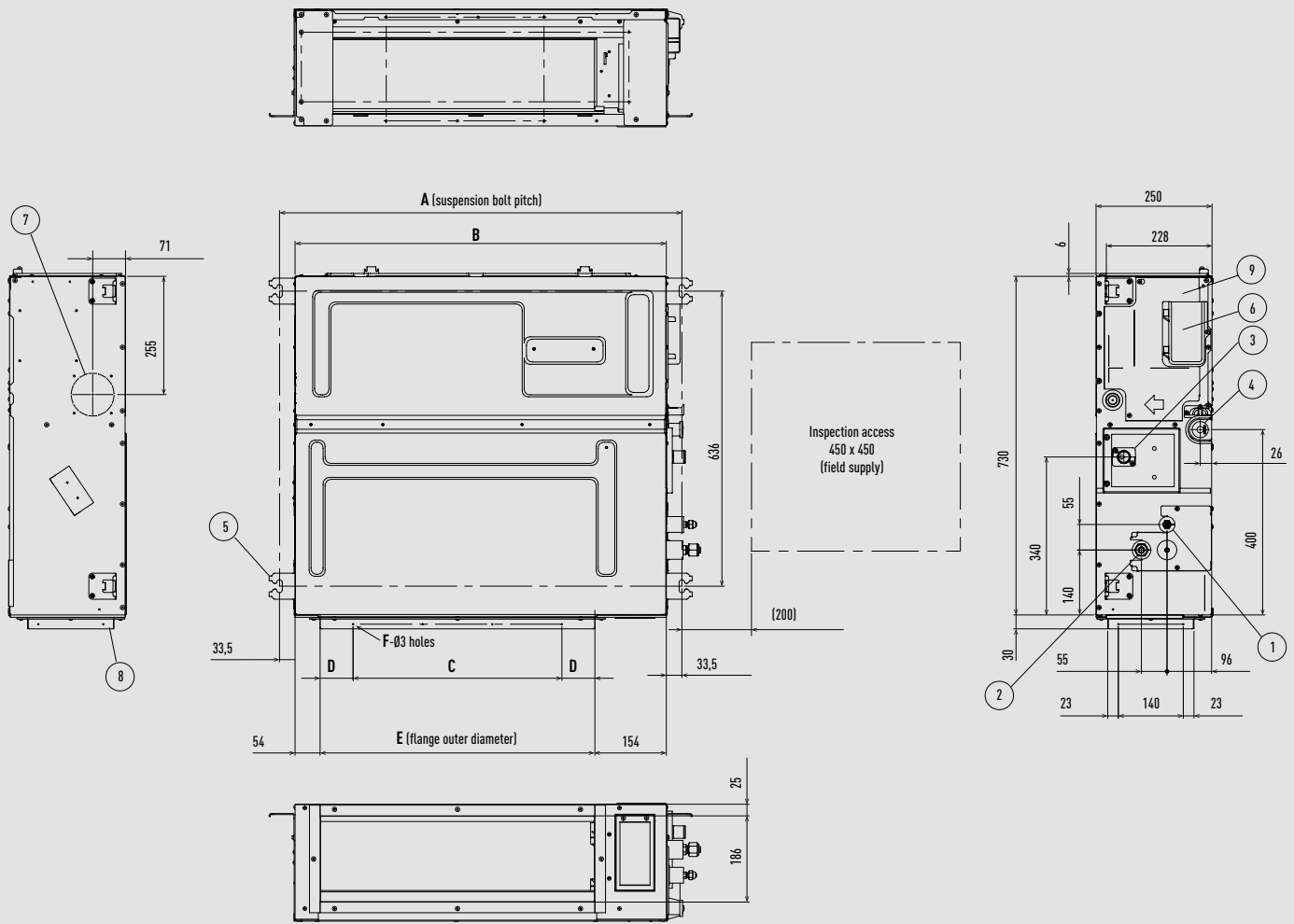

	A	B	C	D	E	F
	mm	mm	mm	mm	mm	Q'ty
S-15MF3E5BN, S-22MF3E5BN, S-28MF3E5BN, S-36MF3E5BN, S-45MF3E5BN, S-56MF3E5BN S-15MF3E5AN, S-22MF3E5AN, S-28MF3E5AN, S-36MF3E5AN, S-45MF3E5AN, S-56MF3E5AN	867	800	450 (pitch 150 x 3)	71	592	12
S-60MF3E5BN, S-73MF3E5BN, S-90MF3E5BN S-60MF3E5AN, S-73MF3E5AN, S-90MF3E5AN	1067	1000	750 (pitch 150 x 5)	21	792	16
S-112MF3E5BN, S-140MF3E5BN, S-160MF3E5BN S-112MF3E5AN, S-140MF3E5AN, S-160MF3E5AN	1467	1400	1050 (pitch 150 x 7)	71	1192	20

Type	15-90	106-160	15-56	60-160
1 Refrigerant piping (liquid)	Ø6,35 (flared)	Ø9,52 (flared)	Ø12,70 (flared)	Ø15,88 (flared)
2 Refrigerant piping (gas)				
3 Upper drain piping connection port VP20		Outer diameter 26 mm, 200 mm flexible hose supplied		
4 Bottom drain piping connection port VP20		Outer diameter 26 mm		
5 Suspension lug		4-12x30 mm		
6 Power supply port				
7 Fresh air inlet duct connection port		Ø100 mm*		
8 Flange for flexible air discharge duct				
9 Electrical component box				

\* Necessary to attach duct connecting flange (field supply).

### M1 type slim variable static pressure hide-away concealed duct.

1	Refrigerant piping (narrow piping)	
2	Refrigerant piping (wide piping)	
3	Upper and bottom drain port	Outer diameter 26 mm
4	Suspension lug	
5	Power supply port	2-Ø30
6	Flange for air inlet duct	
7	PL cover	
8	Electrical component box	
9	Frame filter	
10	Signal output board	ACC-SG-AGB: optional

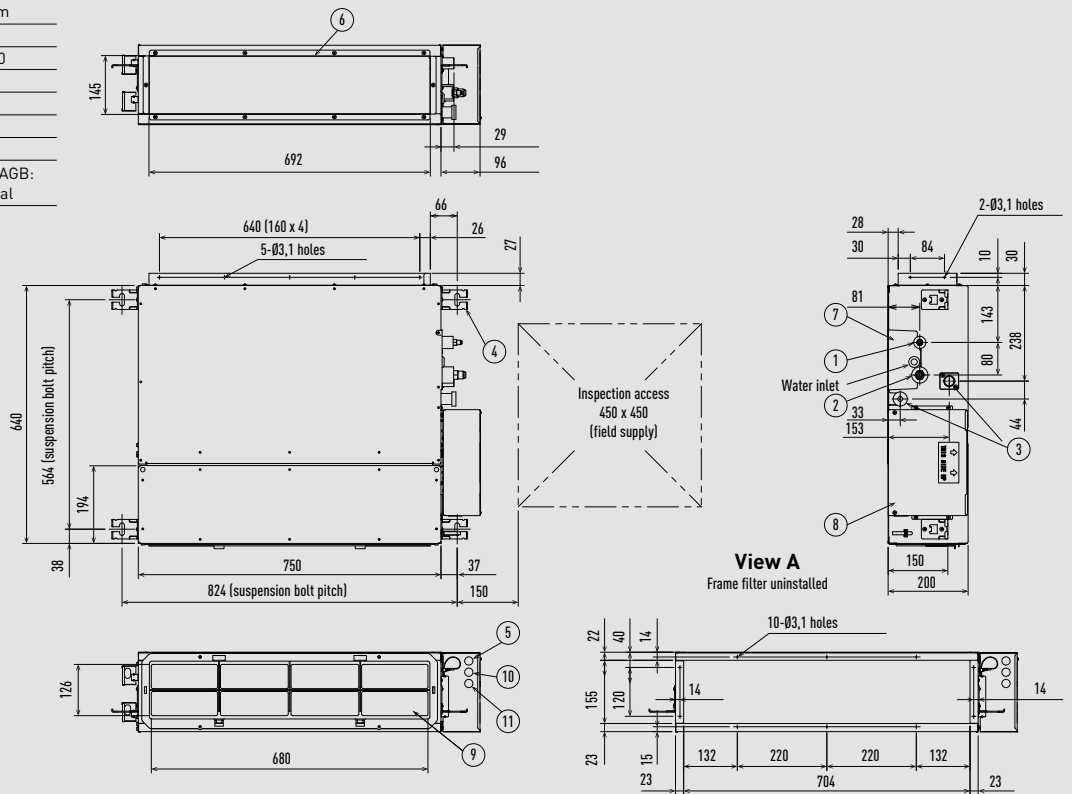

Unit: mm

### E2 type high static pressure hide-away.

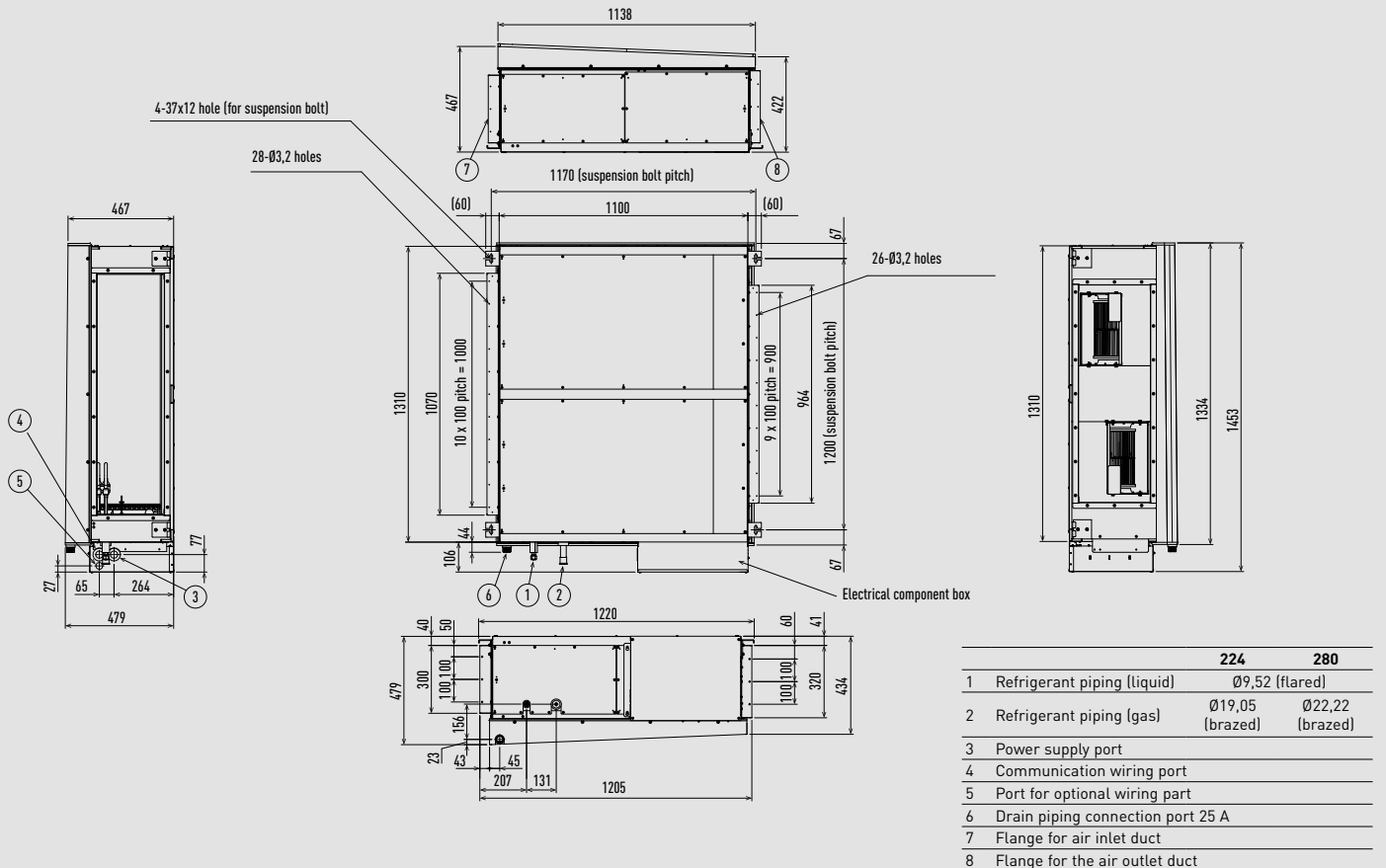

Unit: mm

T2 type ceiling.

S-36MT2E5A / S-45MT2E5A / S-56MT2E5A

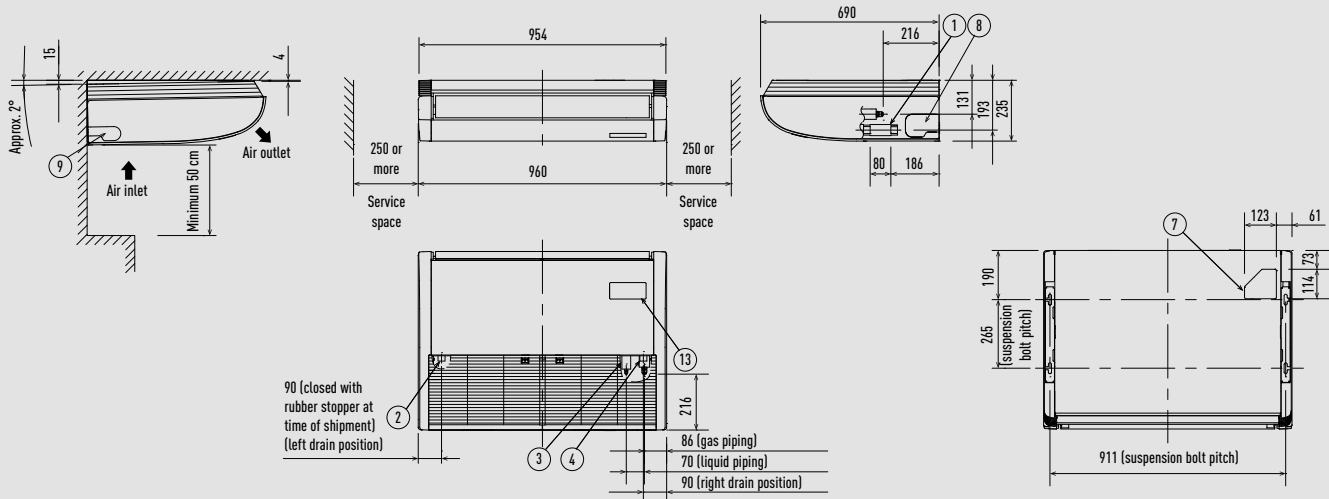

S-73MT2E5A

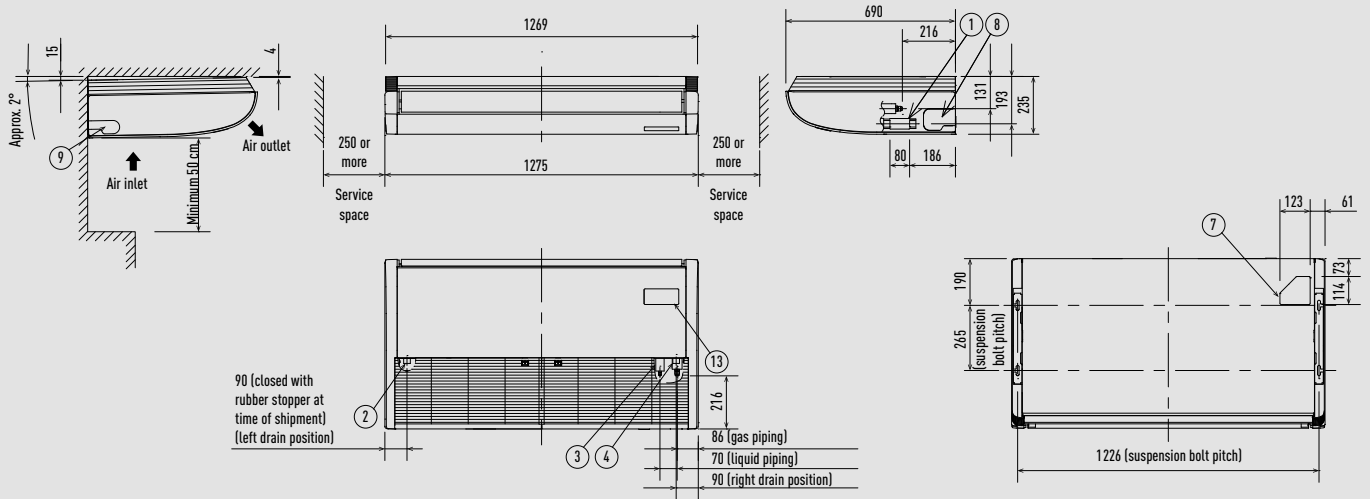

S-106MT2E5A / S-140MT2E5A

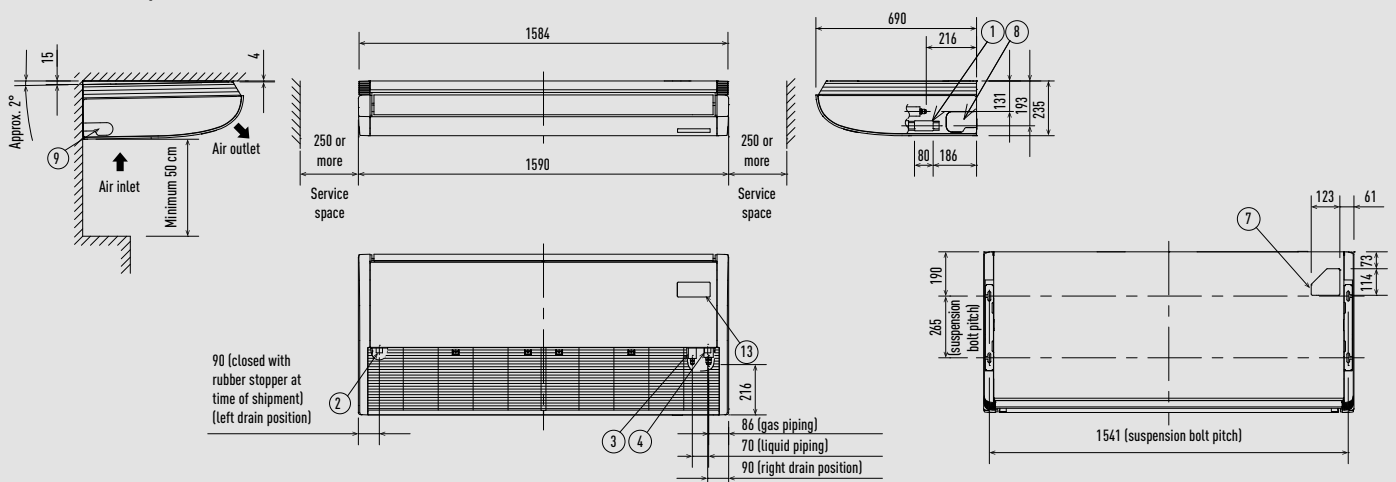

1	Drain piping connection port VP20	Inside diameter 26 mm, drain hose supplied
2	Left drain position	
3	Refrigerant piping (liquid)	Ø9,52 (flared)
4	Refrigerant piping (gas)	Ø15,88 (flared)

5	Left side drain hose outlet port (cutout)	
6	Piping hole on wall surface	Ø100 mm
7	Upper side piping port	
8	Right side drain hose outlet port (cutout)	
9	Wireless remote controller receiver installation location	

Unit: mm



G1 type floor console.

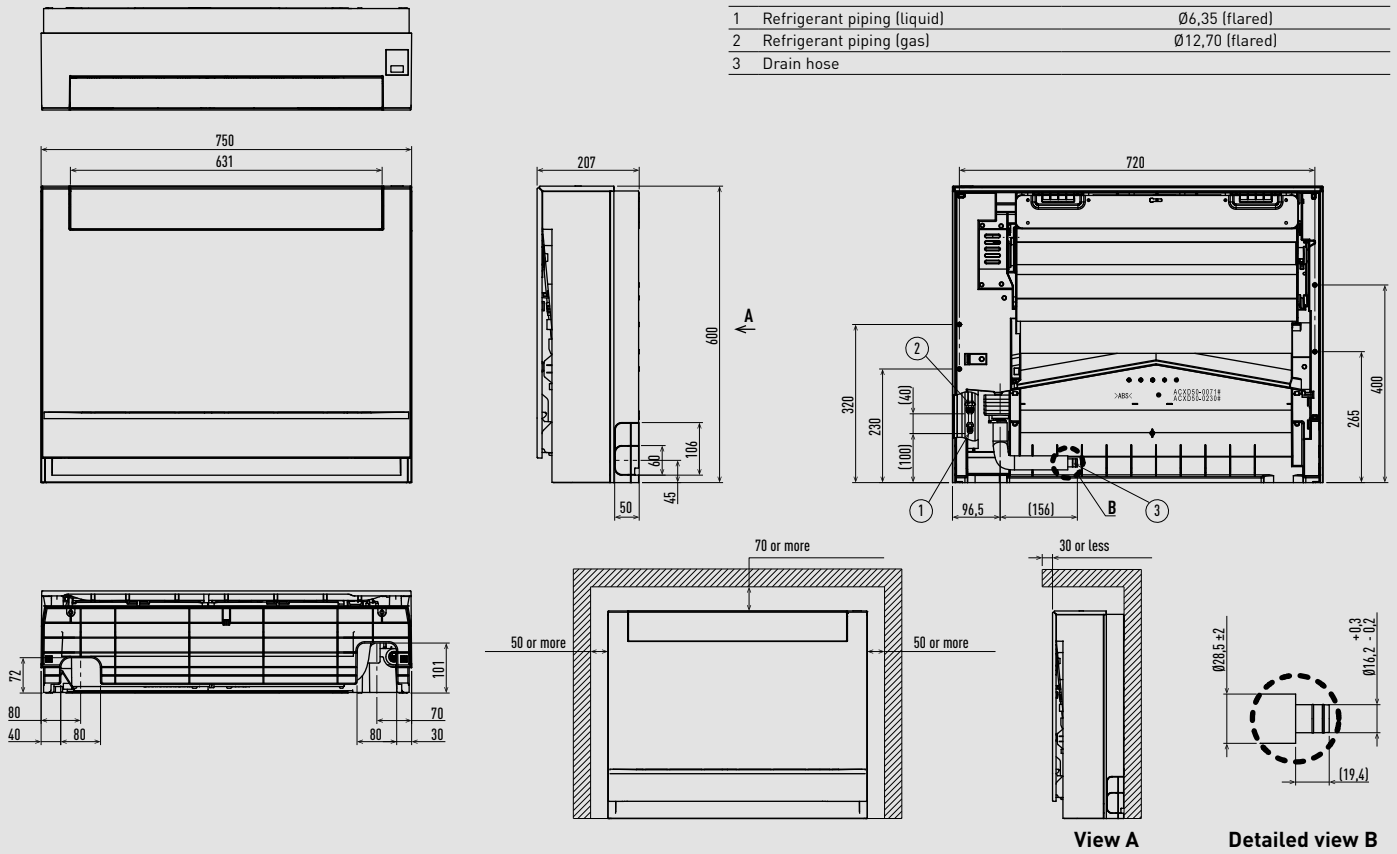

Unit: mm

P1 type floor-standing.

- 1 4-Ø12 holes (for fastening the indoor unit to the floor with screws)
- 2 Air filter
- 3 Refrigerant piping (liquid)
- 4 Refrigerant piping (gas)
- 5 Level adjusting bolt
- 6 Drain piping connection port 20 A
- 7 Power cord outlet (downward, rear)
- 8 Refrigerant piping outlet (downward, rear)
- 9 Location for mounting the remote controller (remote controller can be attached within the room)

	A	B	C	Liquid piping	Gas piping
22-36	1065	665	632		
45				Ø6,35	Ø12,70
56	1380	980	947		
71				Ø9,52	Ø15,88

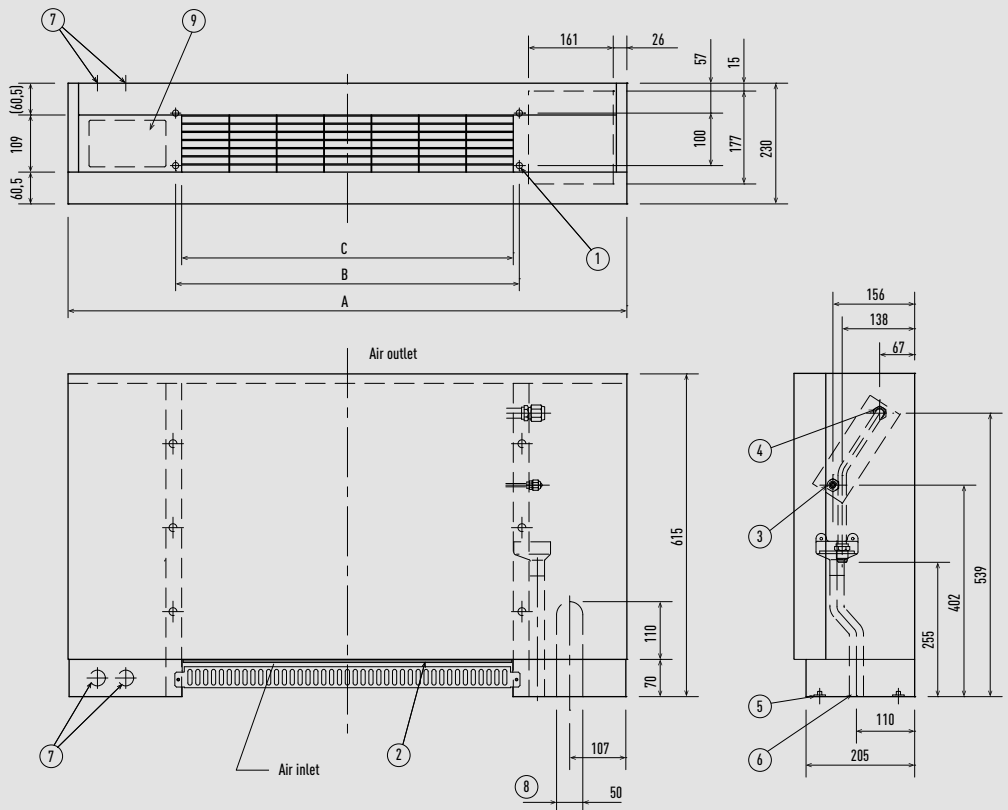

Unit: mm

R1 type concealed floor-standing.

- 1 4-Ø12 holes (for fastening the indoor unit to the floor with screws)
- 2 Air filter
- 3 Refrigerant piping (liquid)
- 4 Refrigerant piping (gas)
- 5 Level adjusting bolt
- 6 Drain piping connection port 20 A
- 7 Flange for the air outlet duct

	22-36	45	56	71
A	904		1219	
B	692		1007	
C	672		1002	
D	665		980	
E	500		900	
F	86		51	
Liquid piping	Ø6,35		Ø9,52	
Gas piping	Ø12,70		Ø15,88	

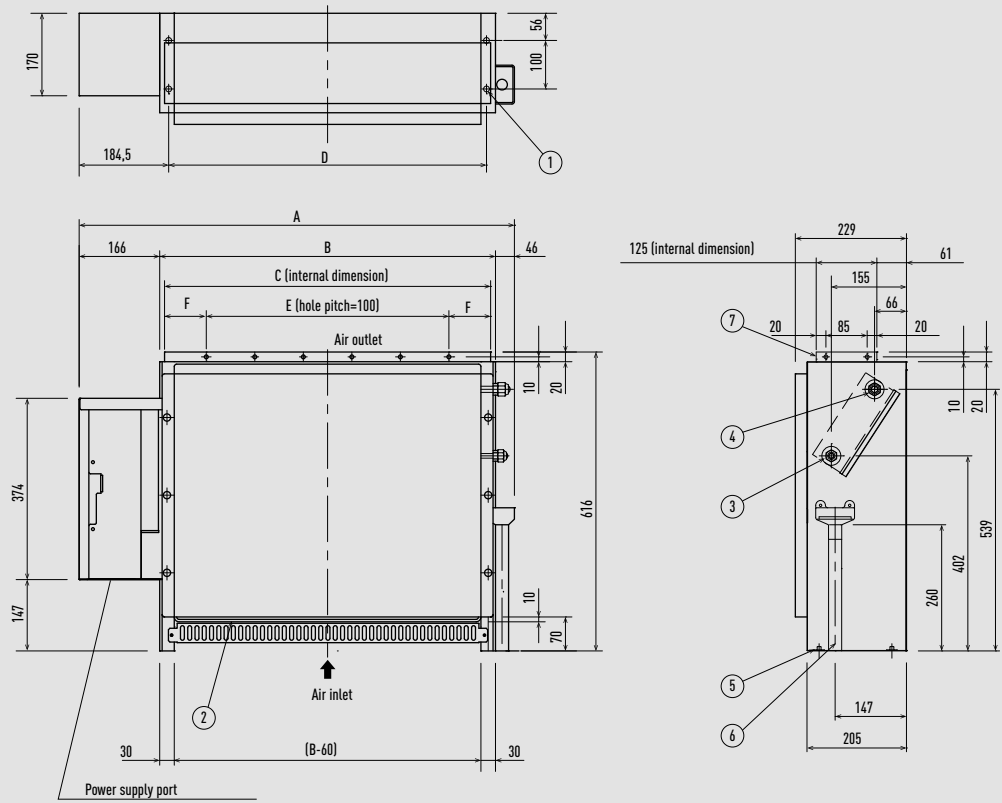

Unit: mm

Hydrokit for ECOi, water at 45 °C.

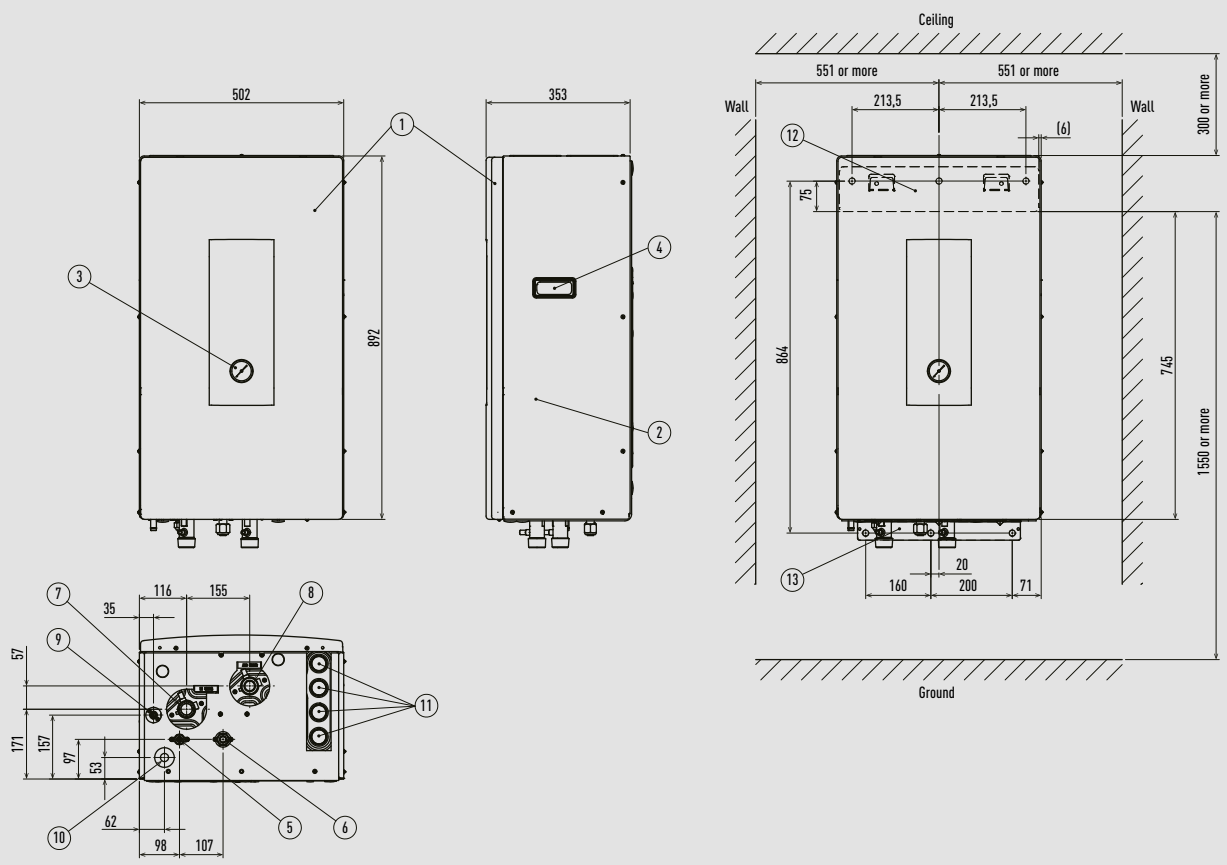

Unit: mm

ERV with DX coil - HRPT Series - PAW-HRPT40HX.

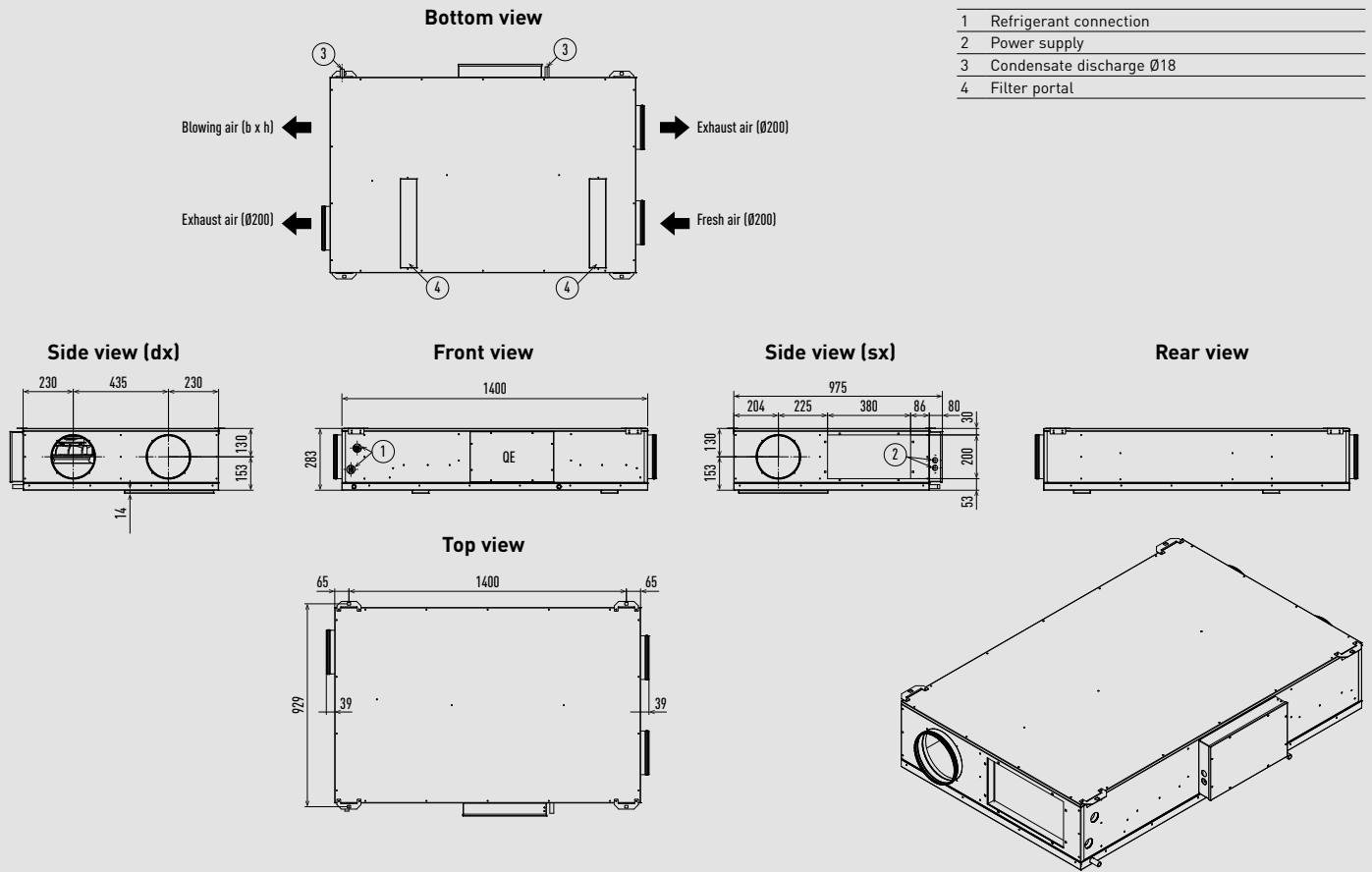

Unit: mm

ERV with DX coil - HRPT Series - PAW-HRPT80HX / PAW-HRPT120HX / PAW-HRPT160HX / PAW-HRPT200HX.

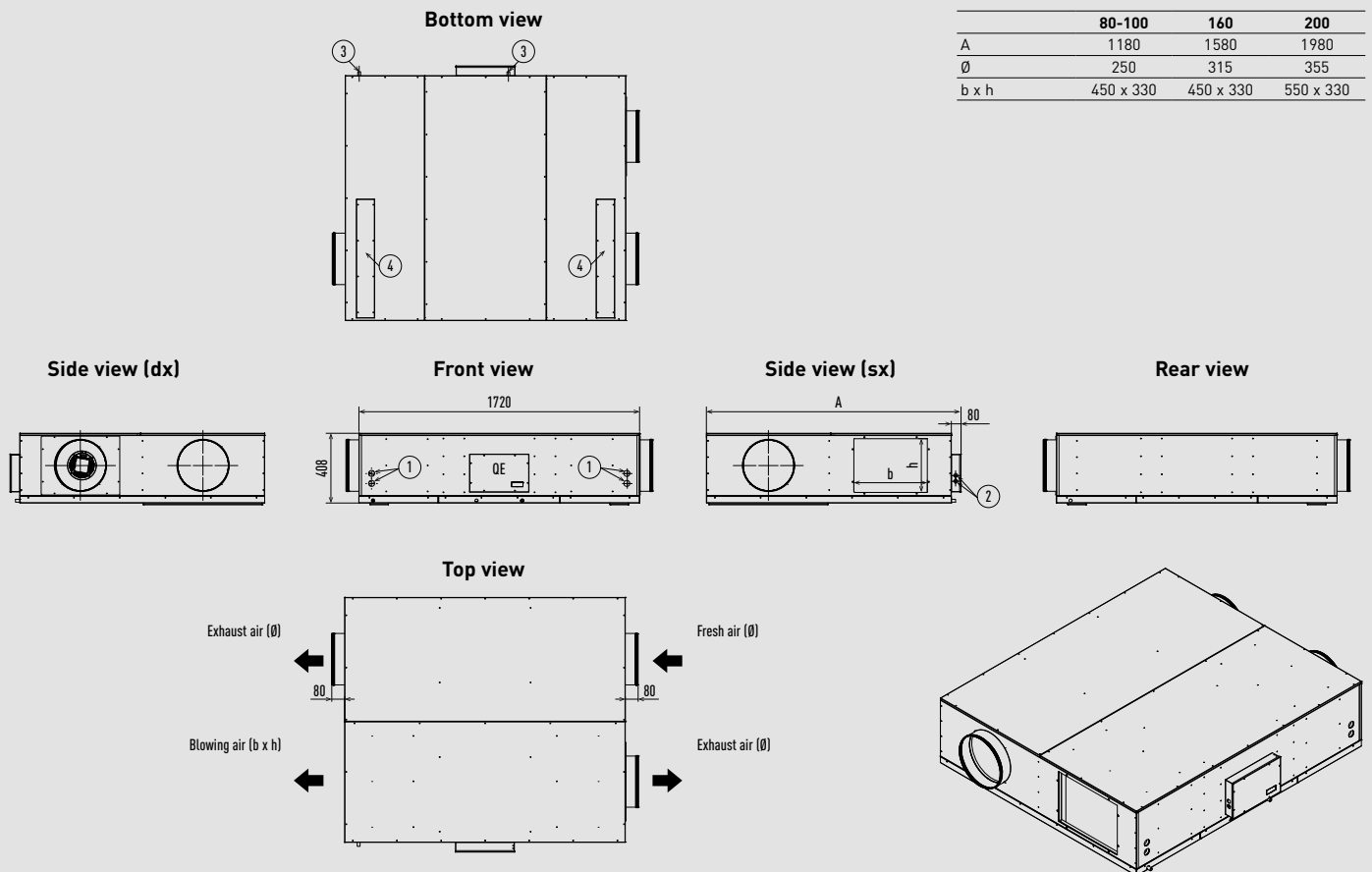

Unit: mm

Heat recovery with DX coil - ZDX Series.

	A	B	C	D	E	E1	F	F1	G	L	T	K	M	N	P	R	S	Y	Z	Net weight
<b>PAW-500ZDX3N</b>	904	1400	107	200	825	1395	960	830	19	955	500	135	270	350	135	135	202	350	135	90 - 98
<b>PAW-800ZDX3N</b>	1134	1745	85	250	1115	1735	1190	1060	19	1200	678	170	388	500	170	170	228	415	195	100 - 110
<b>PAW-01KZDX3N</b>	1216	1700	85	250	1130	1700	1273	1140	19	1290	621	171	388	550	146	241	151	415	195	105 - 120

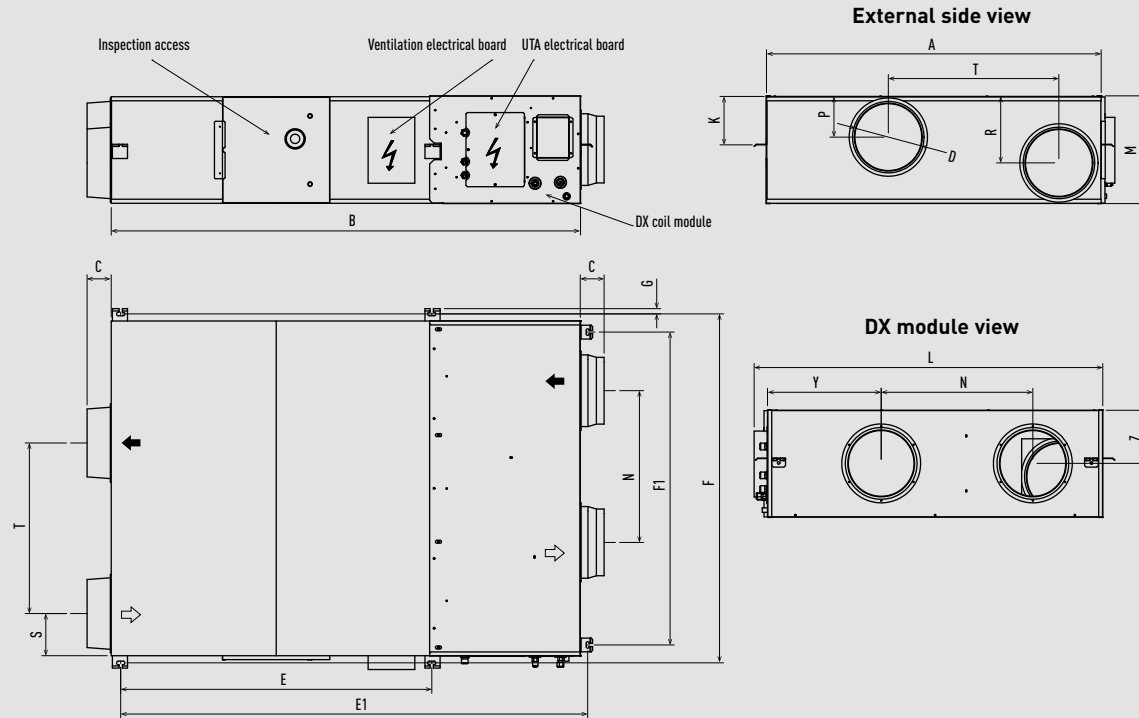

Unit: mm

Smart fan coils.

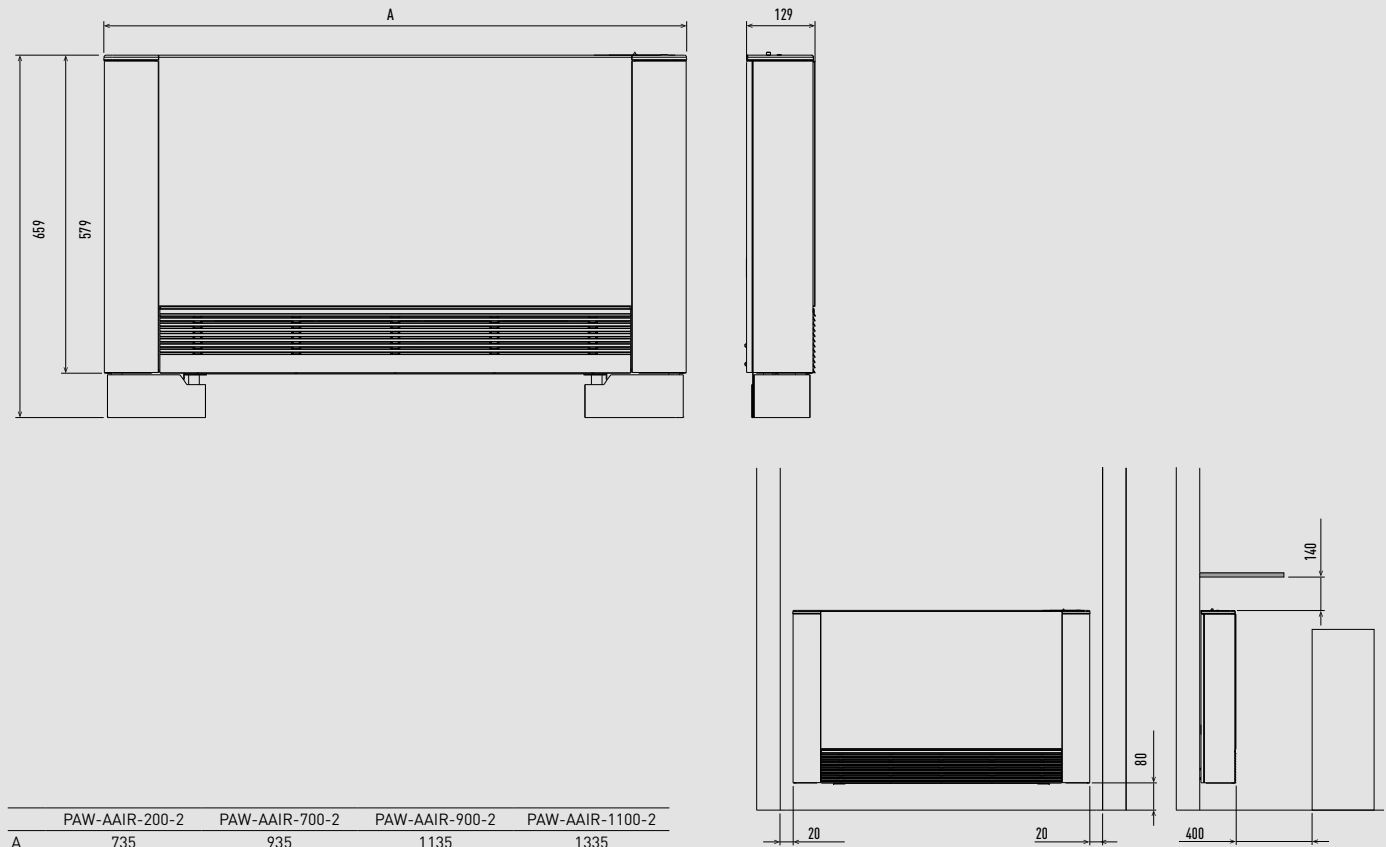

Unit: mm

AHU connection kit for PACi, ECOi and ECO G.

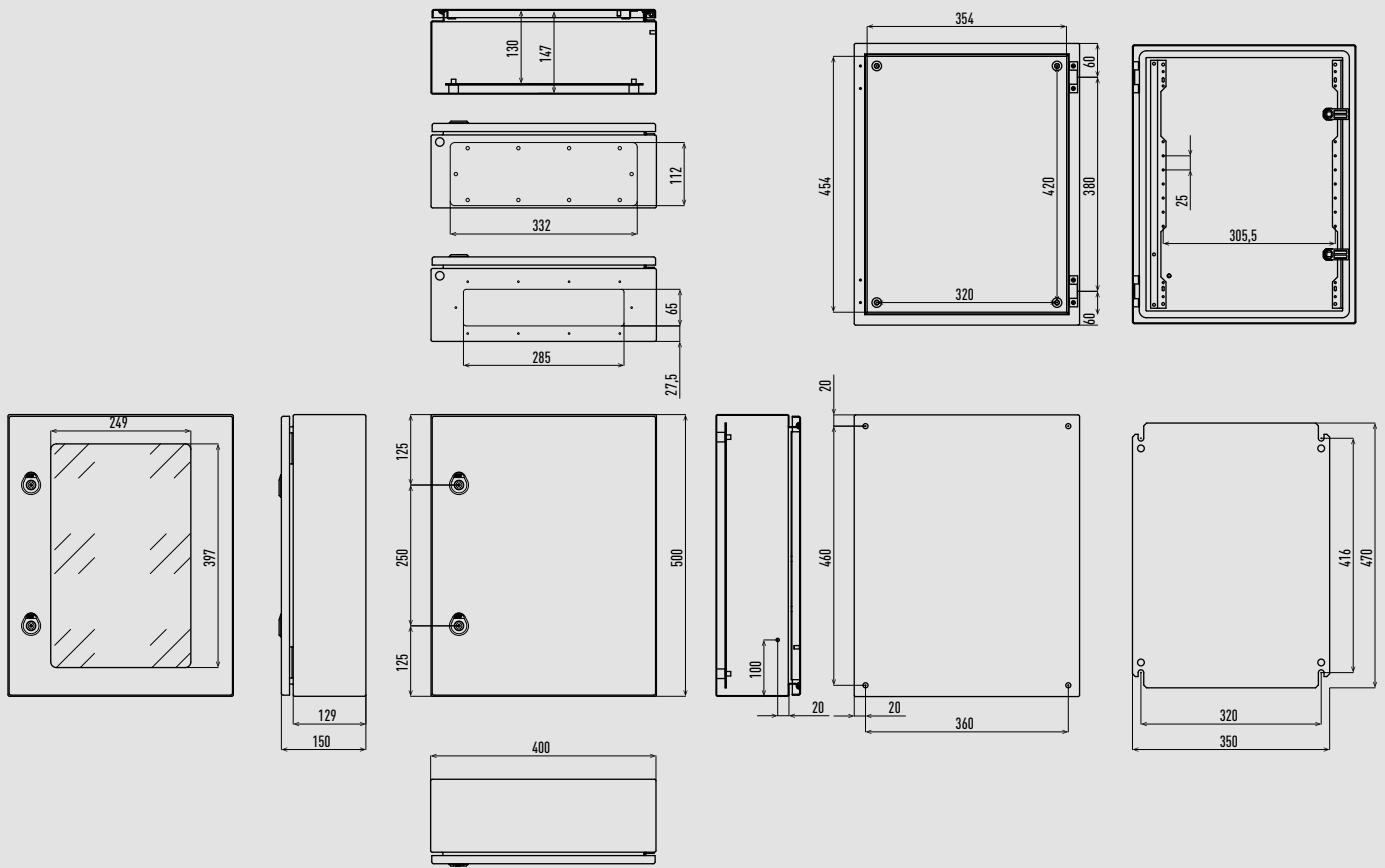

Unit: mm

Advanced energy recovery ventilation - ZY Series.

FV-15ZY1G / FV-25ZY1G / FV-35ZY1G / FV-50ZY1G / FV-65ZY1G / FV-80ZY1G / FV-1KZY1G

	A	B	C	D	E	F	G	H	J	K	L	M	N	Duct diameter
<b>FV-15ZY1G</b>	860	666	786	610	289	144,5	102	Ø97,6	Ø150	395	107,5	116	168	Ø100
<b>FV-25ZY1G</b>	860	791	786	735	289	144,5	102	Ø145	Ø200	470	132,5	116	168	Ø150
<b>FV-35ZY1G</b>	968	930	895	874	331	165,5	102	Ø145	Ø200	609	132,5	115	168	Ø150
<b>FV-50ZY1G</b>	968	1072	895	1016	331	165,5	114	Ø195	Ø250	665	175,5	115	168	Ø200
<b>FV-65ZY1G</b>	1008	1010	934	954	404	202	114	Ø195	Ø250	638	158	121	168	Ø200
<b>FV-80ZY1G</b>	1224	1060	1148	1004	404	202	122	Ø245	Ø300	633	185,5	121	168	Ø250
<b>FV-1KZY1G</b>	1224	1287	1148	1231	404	202	122	Ø245	Ø300	860	185,5	121	168	Ø250

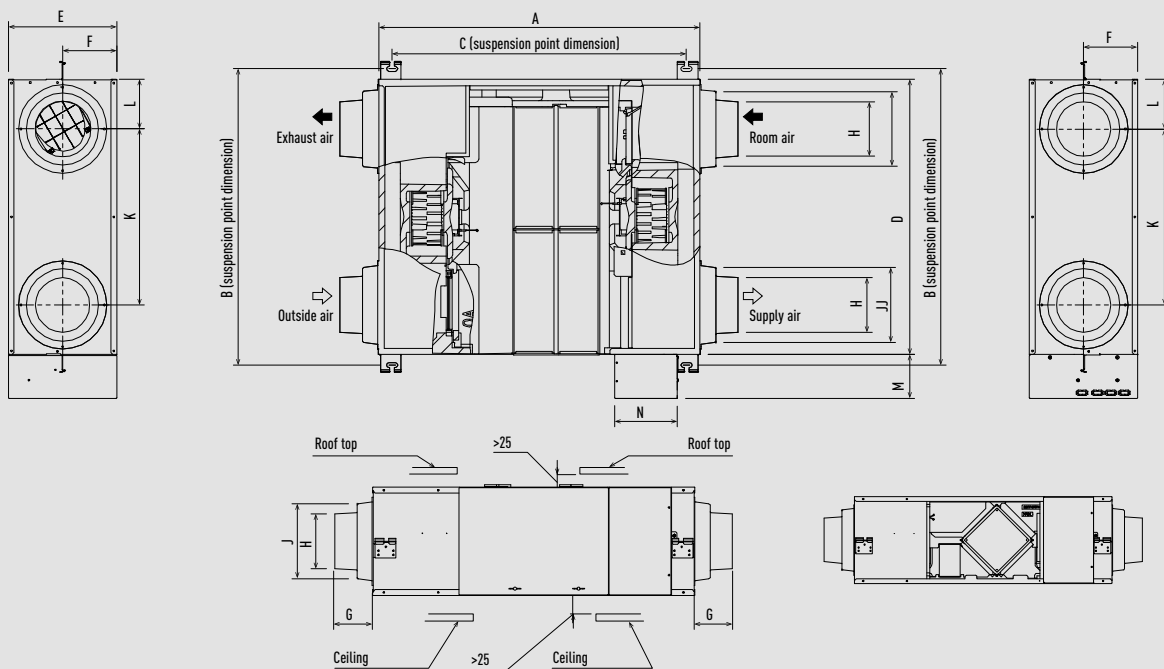

Unit: mm

### Advanced energy recovery ventilation - ZY Series.

FV-1HZY1G / FV-2KZY1G

	A	B	C	D	E	F	G	H	J	K	L	M	N	Duct diameter
FV-1HZY1G	1224	1141	1127	1004	808	202	122	Ø245	Ø300	663	185.5	121	168	Ø250
FV-2KZY1G	1224	1368	1127	1231	808	202	122	Ø245	Ø300	860	185.5	121	168	Ø250

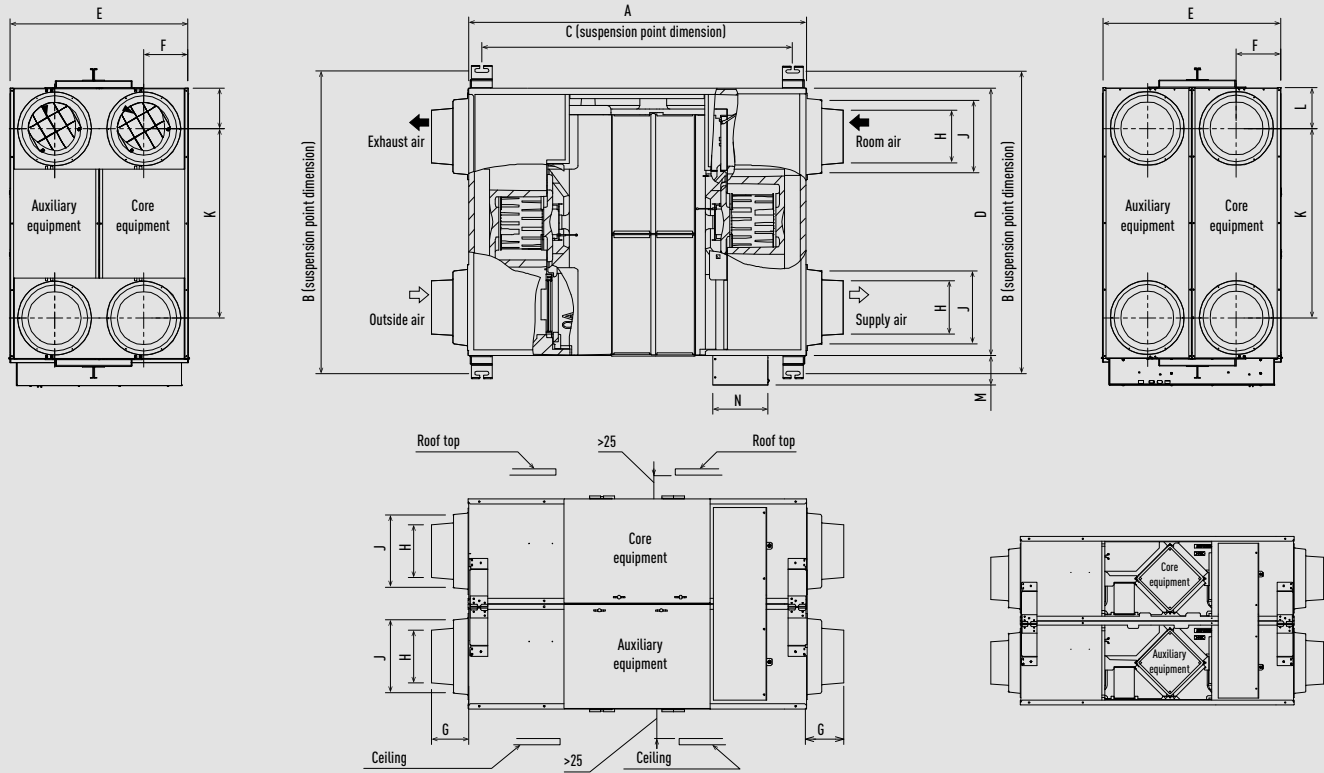

Unit: mm

### Energy recovery ventilation - ZDY Series.

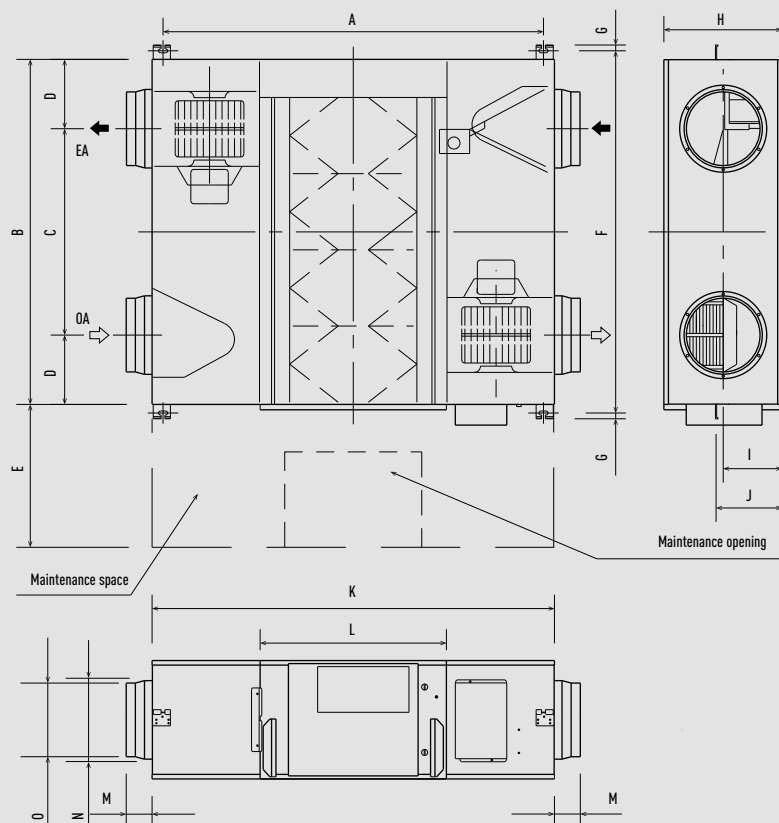

	FY-250ZDY8R	FY-350ZDY8R	FY-500ZDY8R	FY-800ZDY8R	FY-01KZDY8R
A	810	978	1018	1250	1250
B	599	804	904	884	1134
C	315	580	640	428	678
D	142	112	132	228	228
E	600	600	600	600	600
F	655	860	960	940	1190
G	19	19	19	19	19
H	270	317	317	388	388
I	135	159	159	194	194
J	159	182	182	218	218
K	882	1050	1090	1322	1322
L	414	470	470	612	612
M	95	70	70	85	85
N	164	164	210	258	258
O	144	144	194	242	242

Unit: mm

ERV with DX coil - HRPT Series - PAW-HRPT40HX.

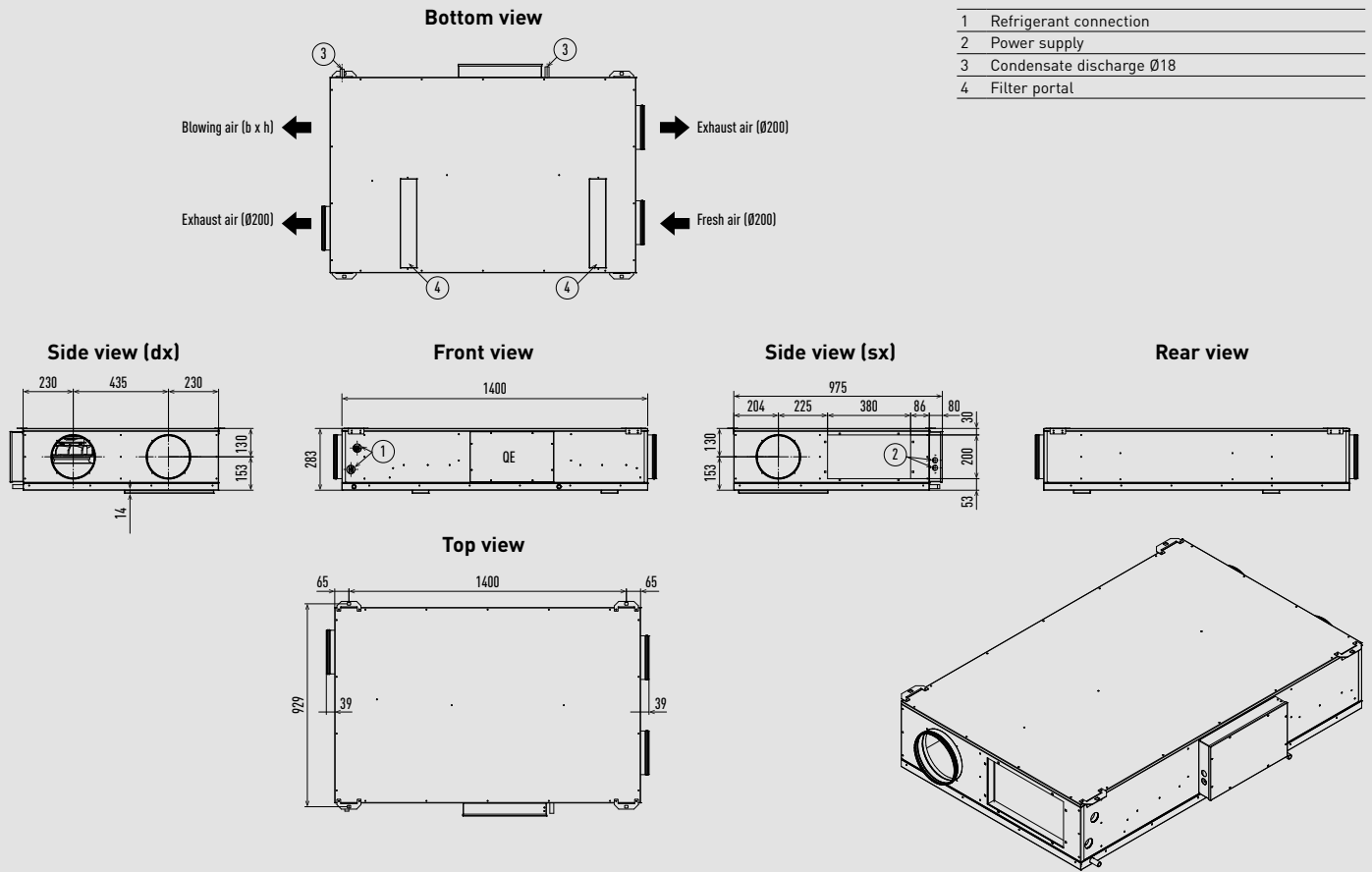

Unit: mm

ERV with DX coil - HRPT Series - PAW-HRPT80HX / PAW-HRPT120HX / PAW-HRPT160HX / PAW-HRPT200HX.

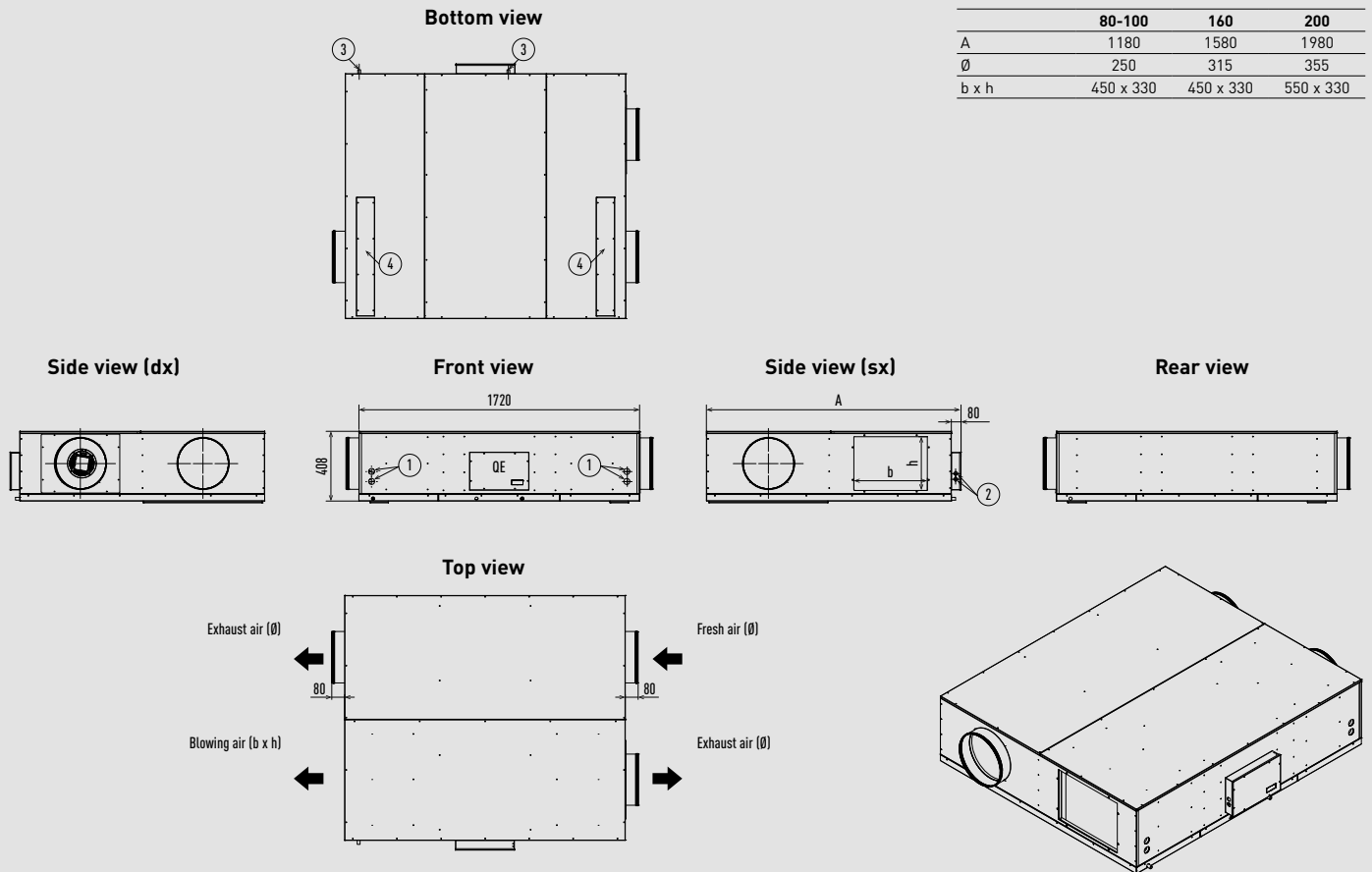

Unit: mm

Heat recovery with DX coil - ZDX Series.

	A	B	C	D	E	E1	F	F1	G	L	T	K	M	N	P	R	S	Y	Z	Net weight
PAW-500ZDX3N	904	1400	107	200	825	1395	960	830	19	955	500	135	270	350	135	135	202	350	135	90 - 98
PAW-800ZDX3N	1134	1745	85	250	1115	1735	1190	1060	19	1200	678	170	388	500	170	170	228	415	195	100 - 110
PAW-01KZDX3N	1216	1700	85	250	1130	1700	1273	1140	19	1290	621	171	388	550	146	241	151	415	195	105 - 120

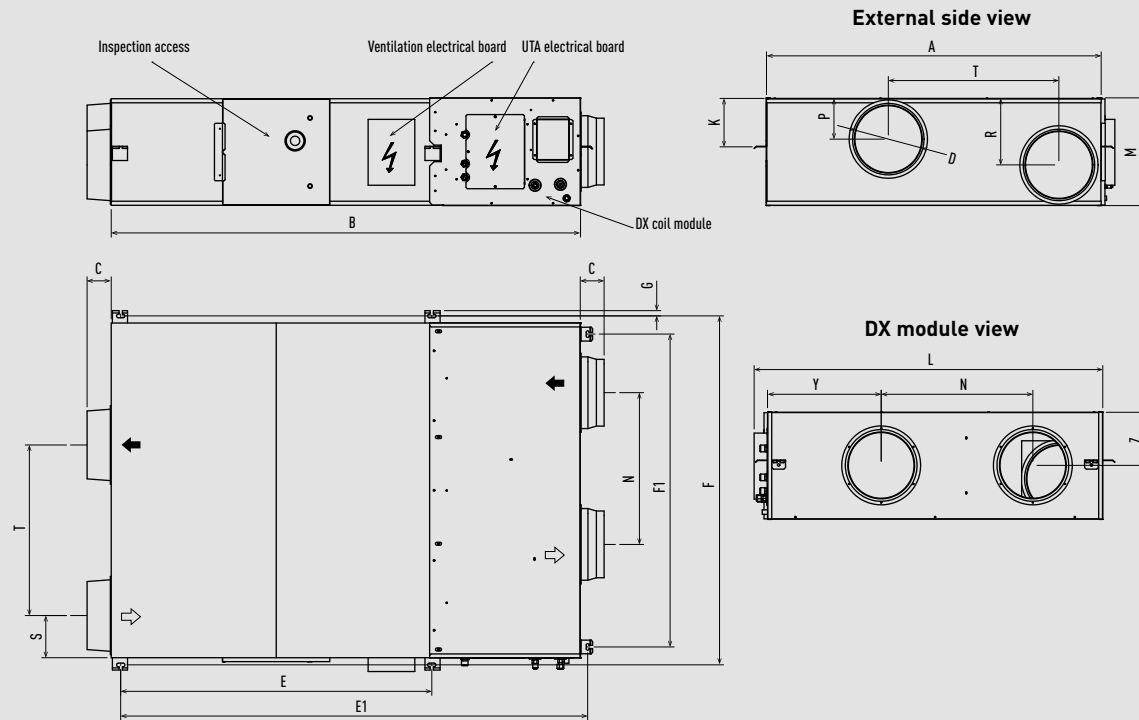

Unit: mm

Electric air curtain.

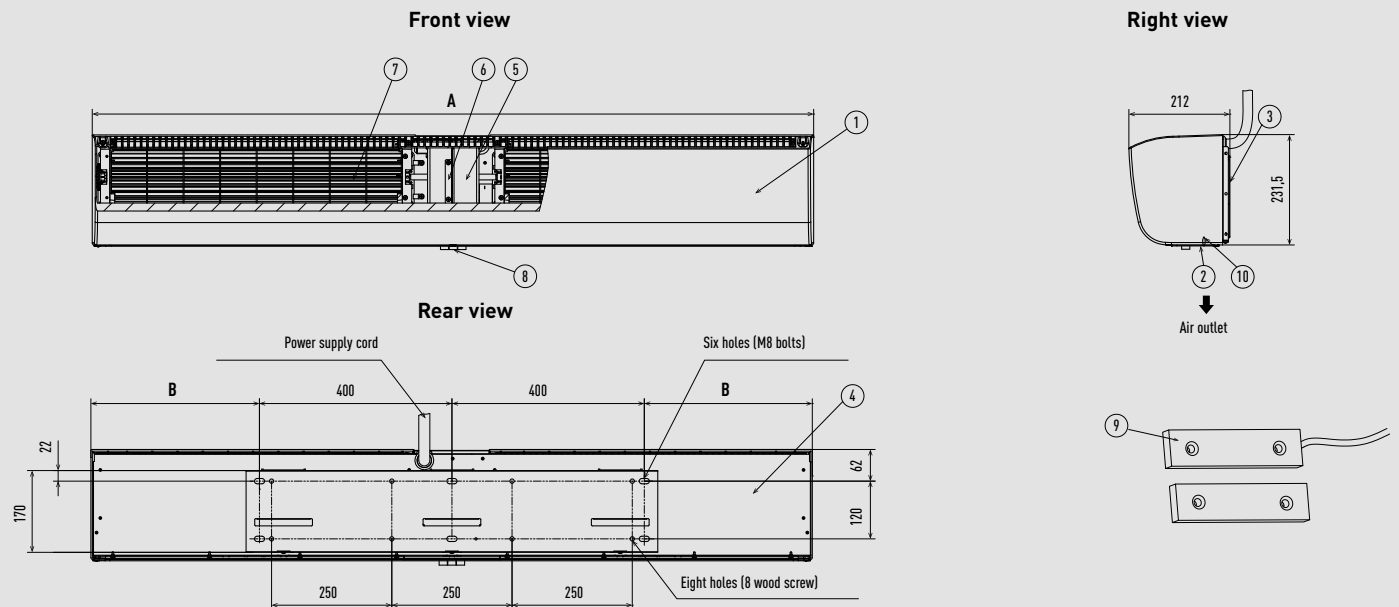

- |                  |                        |
|------------------|------------------------|
| 1 Front panel    | 6 Motor support        |
| 2 Air outlet     | 7 Cross-flow impeller  |
| 3 Mounting plate | 8 Push-button switch   |
| 4 Back panel     | 9 Gate magnetic switch |
| 5 Motor          | 10 Guide plate         |

	FY-3009U1	FY-3012U1	FY-3015U1
A	900	1200	1500
B	50	200	350

Unit: mm

Air curtain with DX coil.

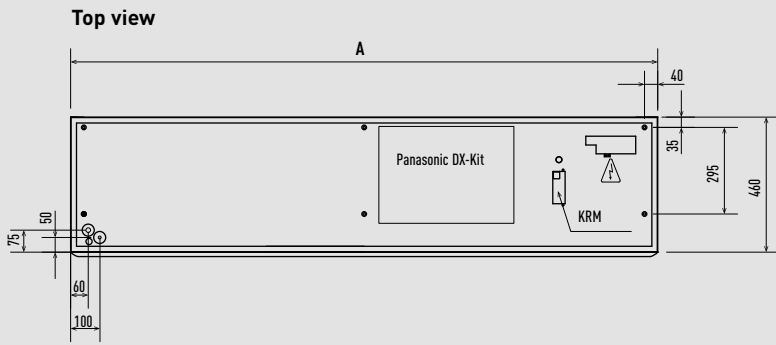

Side view

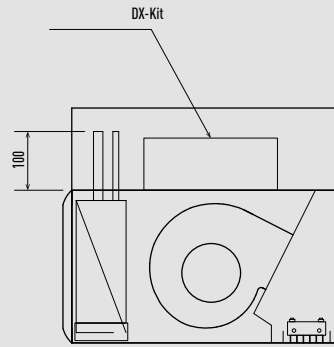

Front view

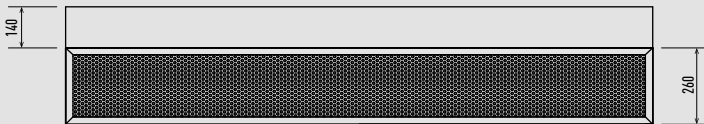

Bottom view

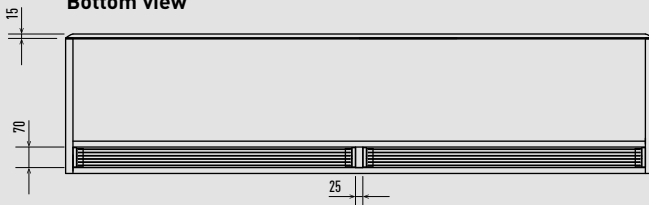

PAW-10PAIRC-LS	PAW-15PAIRC-LS	PAW-20PAIRC-LS	PAW-25PAIRC-LS	
PAW-10PAIRC-HS	PAW-15PAIRC-HS	PAW-20PAIRC-HS	PAW-25PAIRC-HS	
PAW-10EAIRC-LS	PAW-15EAIRC-LS	PAW-20EAIRC-LS	PAW-25EAIRC-LS	
PAW-10EAIRC-HS	PAW-15EAIRC-HS	PAW-20EAIRC-HS	PAW-25EAIRC-HS	
A	1,0m	1,5m	2,0m	2,5m

Unit: mm

E2 type high static pressure hide-away.

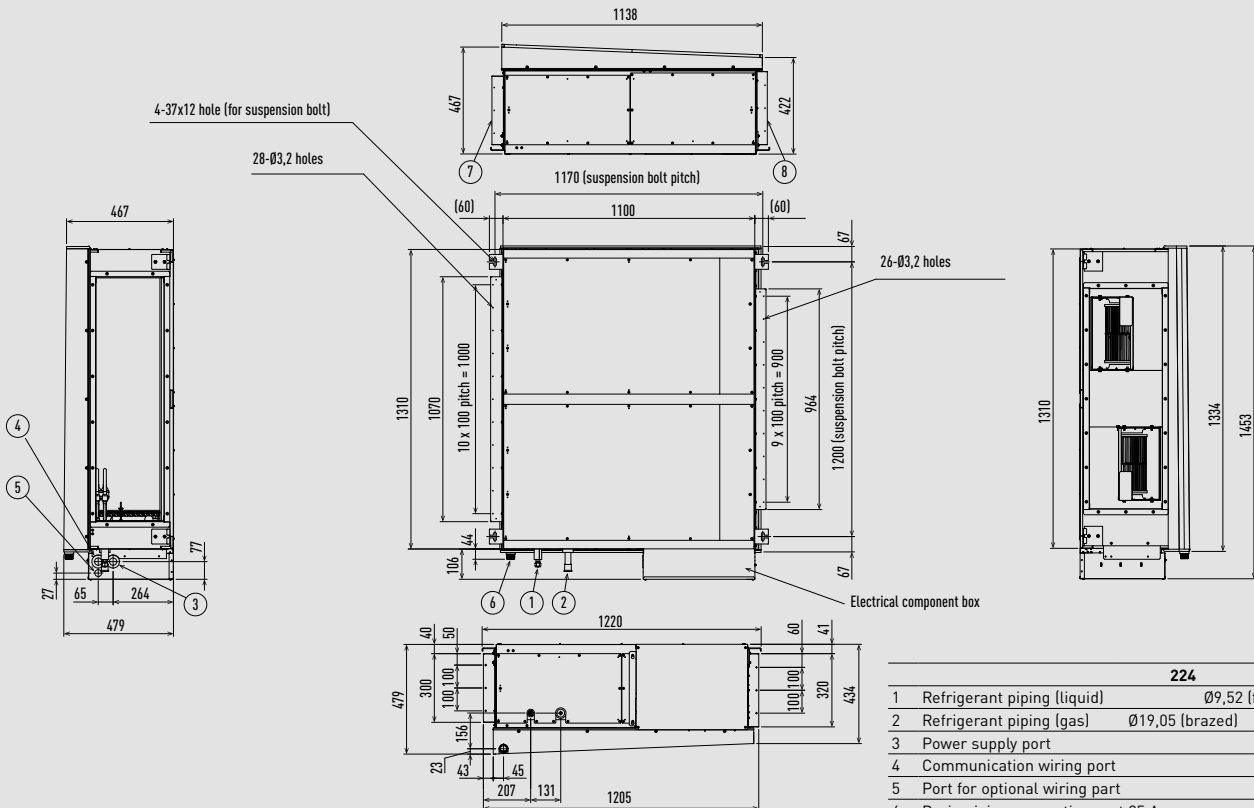

	224	280
1 Refrigerant piping (liquid)	Ø9,52 (flared)	
2 Refrigerant piping (gas)	Ø19,05 (brazed)	Ø22,22 (brazed)
3 Power supply port		
4 Communication wiring port		
5 Port for optional wiring part		
6 Drain piping connection port 25 A		
7 Flange for air inlet duct		
8 Flange for the air outlet duct		

Unit: mm

Ceiling mounted air-e nanoe X Generator.

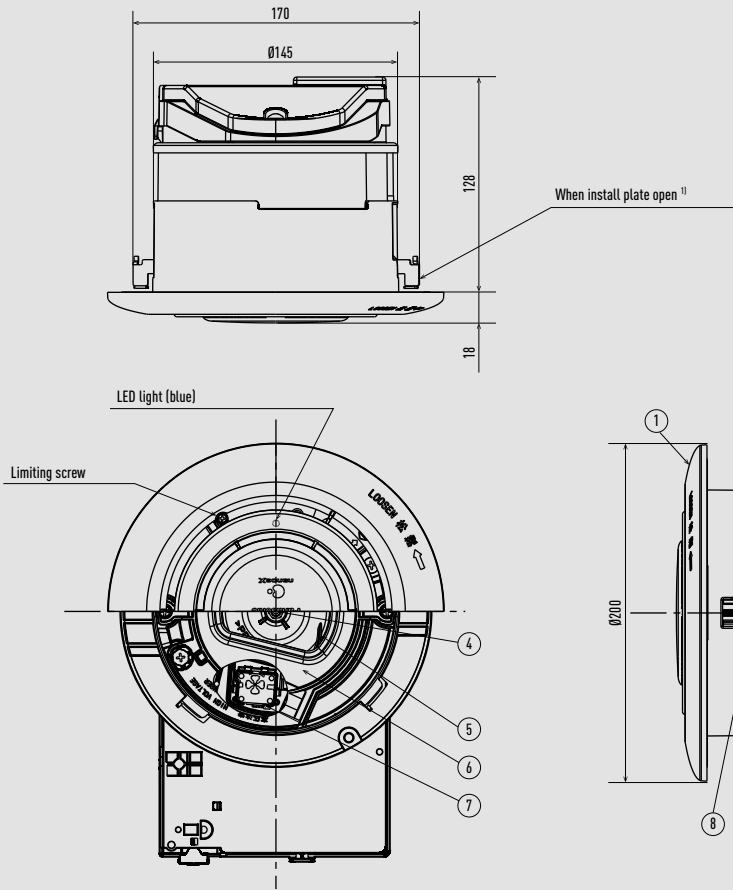

	Quantity
1 Louvre	1
2 Frame	1
3 Electric case assy	1
4 Motor	1
5 Fan	1
6 Orifice assy	1
7 nanoe™ X unit	1
8 Install screw	2
9 Install plate	2

1) Initial position of install plate is closed.

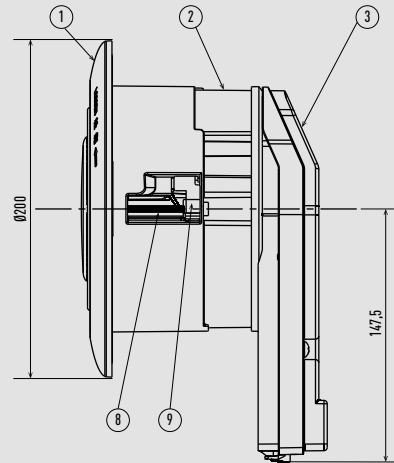

Unit: mm

Heat recovery ventilation unit.

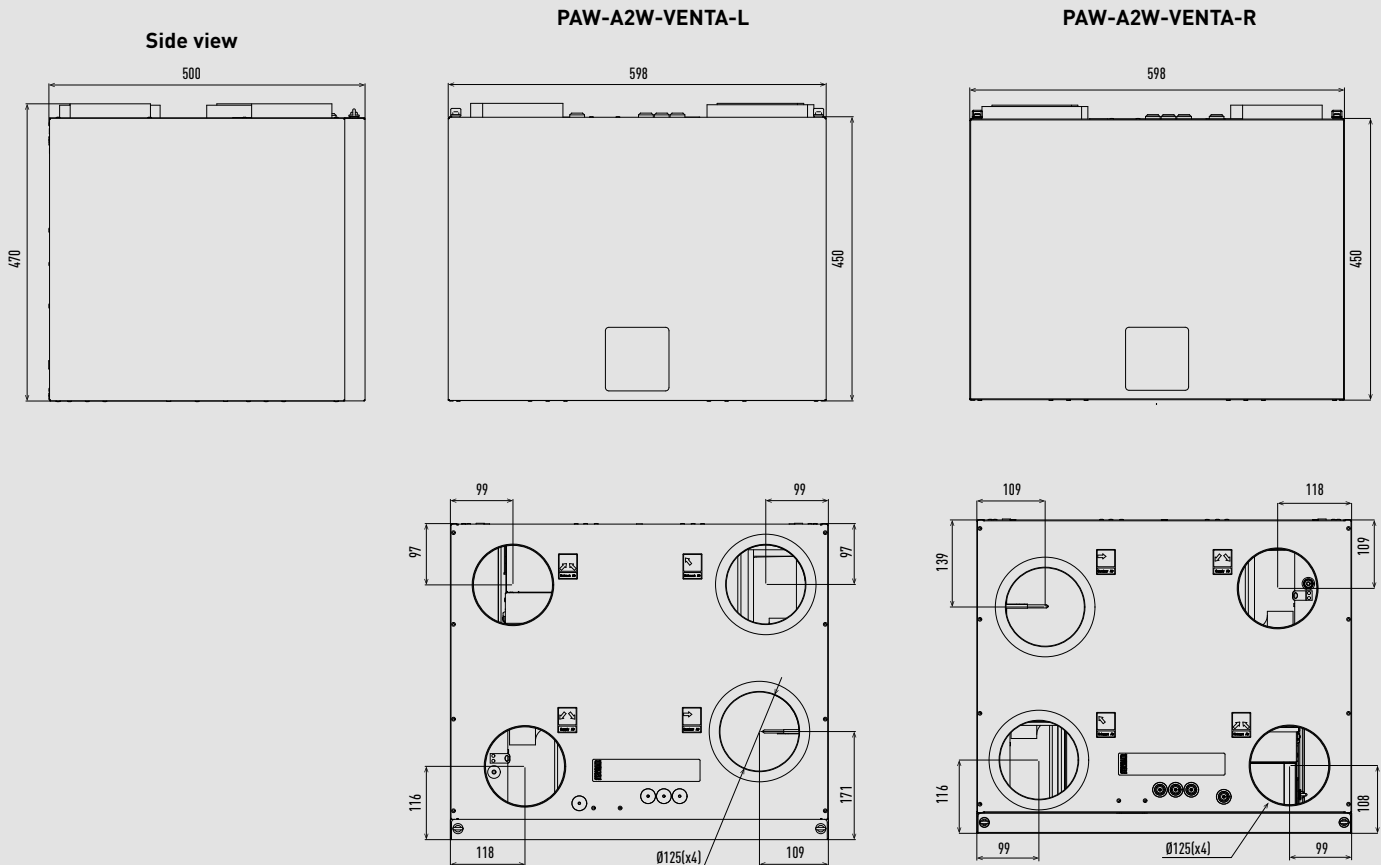

Unit: mm

Counter flow ventilation - PAW-VENTX10Z / PAW-VENTX15Z.

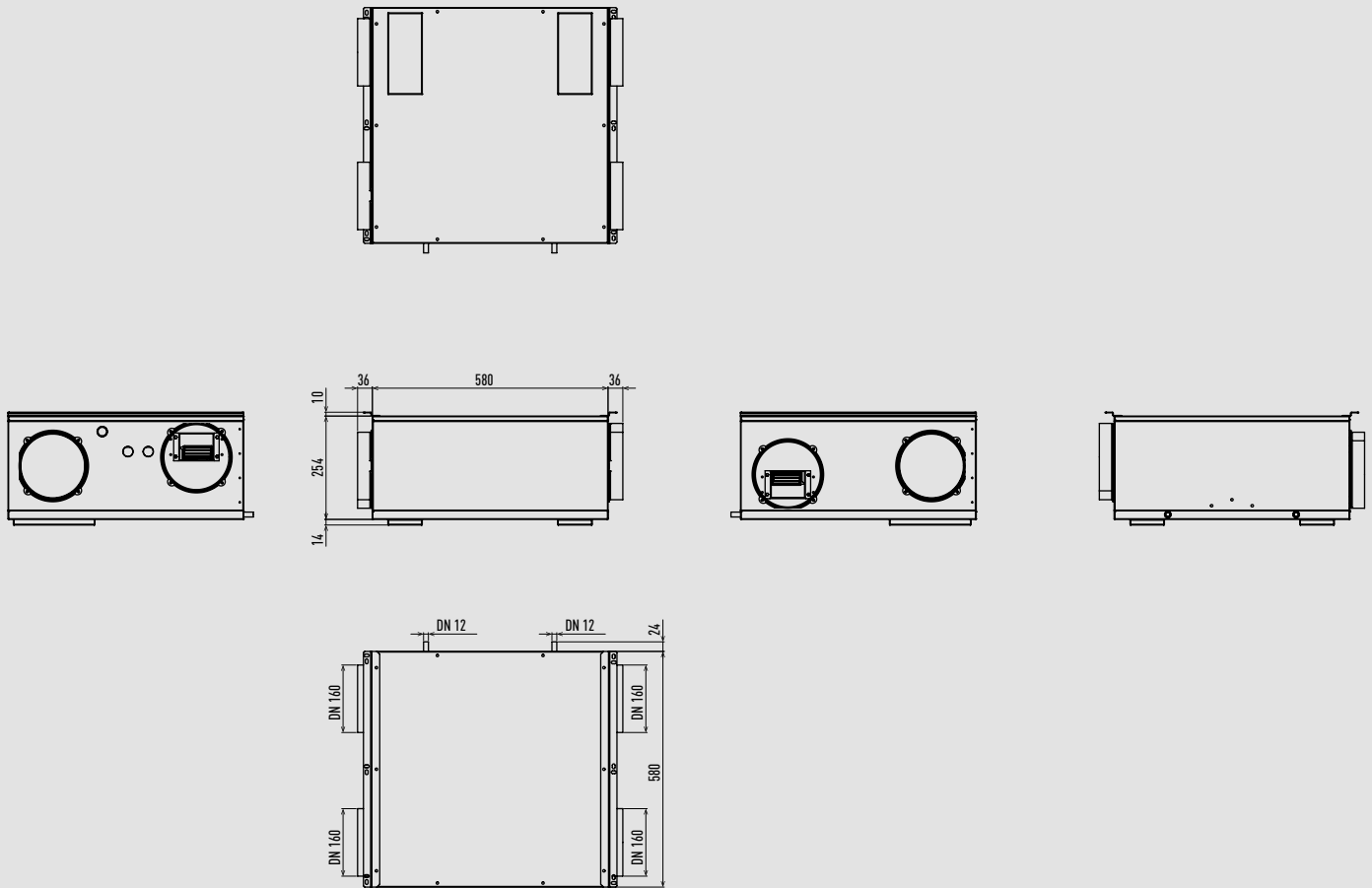

Unit: mm

Counter flow ventilation - PAW-VENTX20H / PAW-VENTX30H / PAW-VENTX40H.

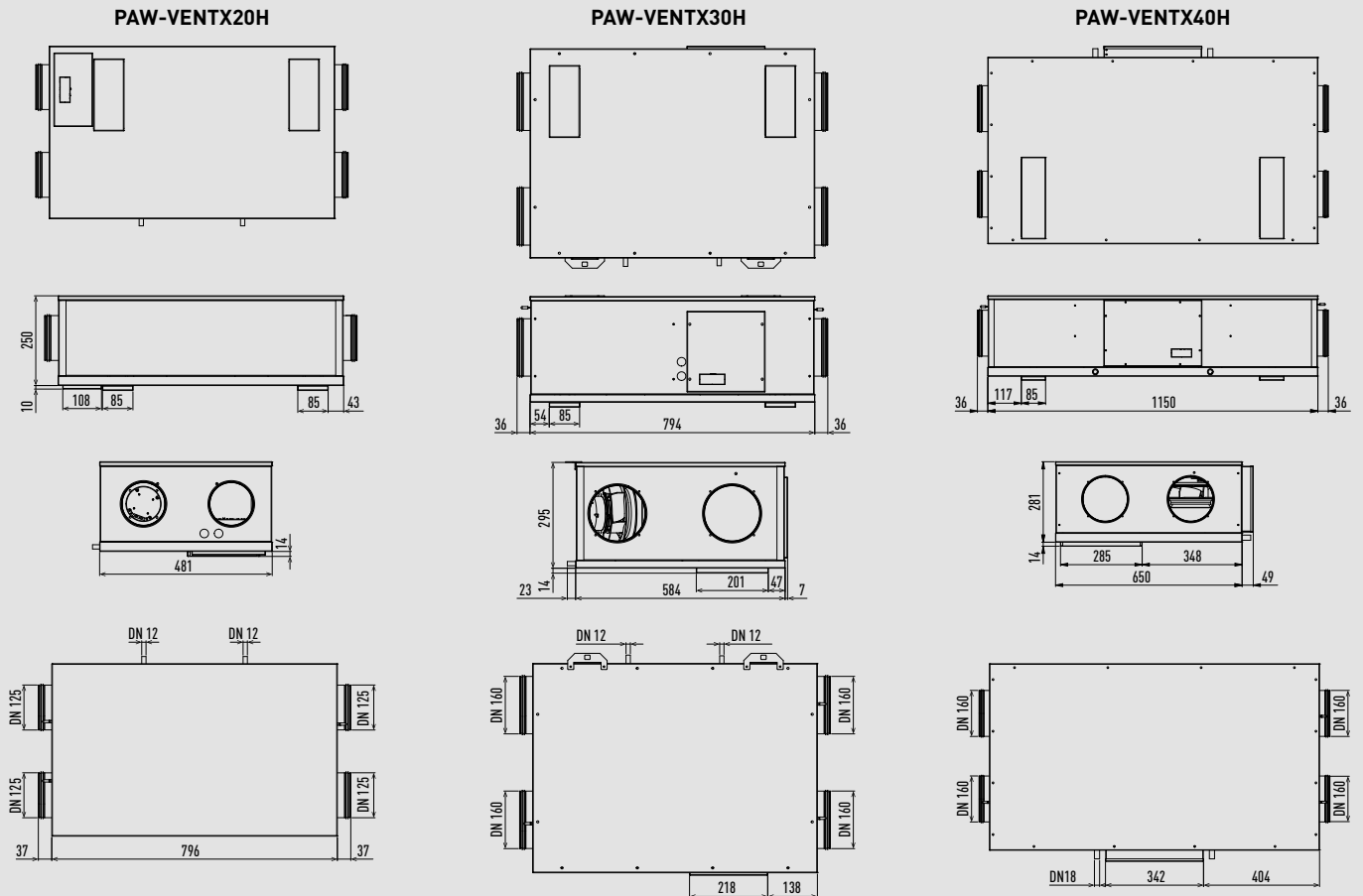

Unit: mm

Counter flow ventilation - PAW-VENTX20V / PAW-VENTX30V / PAW-VENTX40V.

PAW-VENTX20V

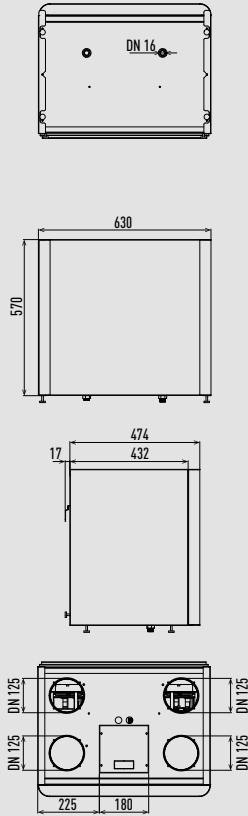

PAW-VENTX30V

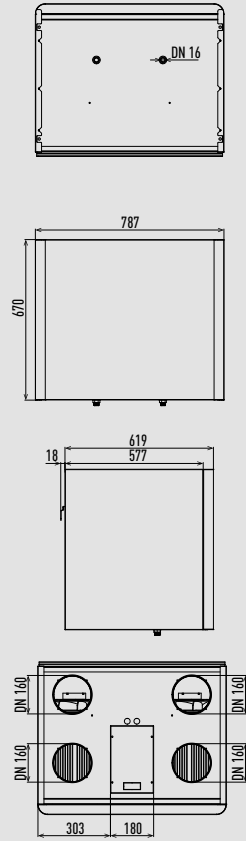

PAW-VENTX40V

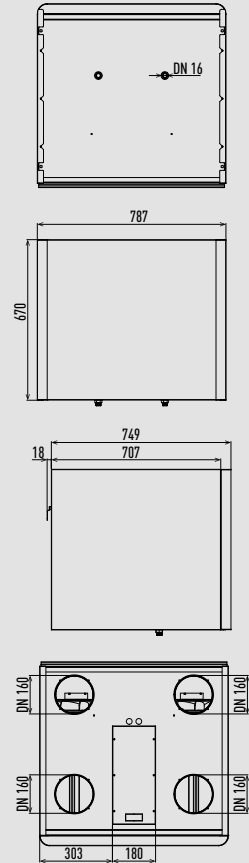

Unit: mm

Room controller for SE8000.

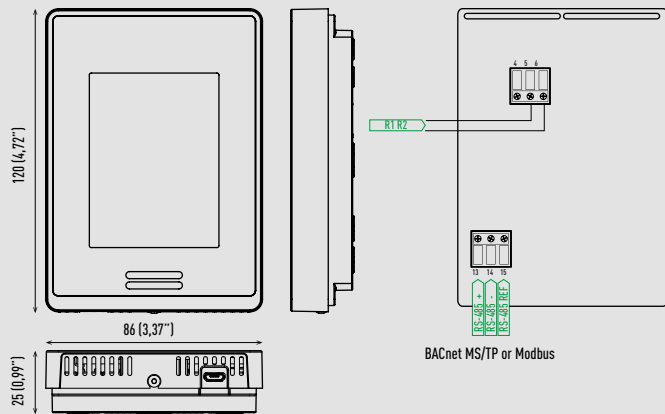

Check with your local government for instruction on disposal of these products.

THIS PRODUCT FOR COMMERCIAL USE ONLY.



**Dimensions:**

Height: 12 cm/4,72 in.  
Width: 8,6 cm/3,39 in.  
Depth: 2,7 cm/1,06 in.

**Power requirements:**

16 V DC from Panasonic R-R IDU connectors.  
50/60 Hz, 4 VA, Class 2 Supply.

**Range from indoor unit:**

Recommended 500 ft (150 m).

**Operating conditions:**

0 °C to 50 °C [32 °F to 122 °F].  
0% to 95% R.H. non-condensing.

**Storage conditions:**

-30 °C to 50 °C [-22 °F to 122 °F].  
0% to 95% R.H. non-condensing.

**Temperature sensor:**

Local 10 K NTC type 2 thermistor.

**Temperature sensor resolution:**

± 0,1 °C (± 0,2 °F).

**Temperature sensor accuracy:**

± 0,5 °C (± 0,9 °F) @ 21 °C [70 °F] typical calibrated.

**Humidity sensor and calibration:**

Single point calibrated bulk polymer type sensor.

**Humidity sensor precision:**

Reading range from 10% to 90% R.H. non-condensing.  
10% to 20% precision: 10%.  
20% to 80% precision: 5%.  
80% to 90% precision: 10%.

**Humidity sensor stability:**

Less than 1,0% yearly (typical drift).

**Wiring:**

Maximum wire length between last indoor unit to SER8150Rx1194 equals 490 ft (150 m) with AWG #18 wire (0,82 mm<sup>2</sup>). Refer to Panasonic VRF guidelines "Wiring system diagram for remote controller" for this limitation.

**Approximate shipping weight:**

0,34 kg (0,75 lb)

Unit: mm

SED-MTH-G-5045 wall/ceiling wireless sensor.

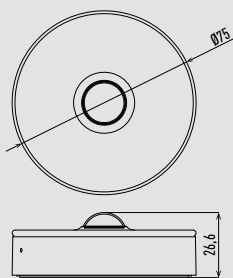

**Dimensions:**  
70 mm diameter x 26,6 mm.

**Colour:**  
White.

**Weight:**  
59 g.

**Communication:**  
ZigBee 3,0 HA.

**Detection range:**  
Ceiling: Ø4m (installation height 2,5 m).  
Wall: R5m (installation height 1,2 m).

**Battery voltage:**  
3 V.

**Battery cell:**  
LR03 AAA (2 pcs).

**Battery life:**  
Up to 5 years.

**Ambient temperature:**  
-10 °C ~ +50 °C.



Check with your local government for instruction on disposal of these products.

SED-WDC-G-5045 door/window wireless sensor.

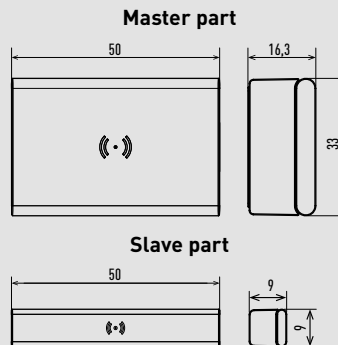

**Dimensions:**  
Master part: 50 x 33 x 16,3 mm.  
Slave part: 50 x 9 x 9 mm.

**Colour:**  
White / transparent.

**Weight:**  
30 g

**Communication:**  
ZigBee 3,0 HA.

**Detection range:**  
Trigger 'close': wood 30 mm, metal 18 mm.  
Trigger 'open': wood 32 mm, metal 20 mm.

**Battery voltage:**  
3 V.

**Battery cell:**  
CR2450.

**Battery life:**  
Up to 5 years.

**Ambient temperature:**  
-10 °C ~ +50 °C.



Check with your local government for instruction on disposal of these products.

Unit: mm

SED-CO2-G-5045 CO<sub>2</sub> sensor.

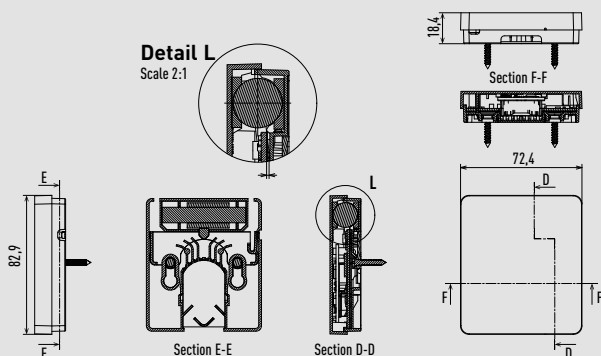

**Dimensions:**  
3,26 x 2,85 x 0,72 inches.  
82,9 x 72,4 x 18,4 mm.

**Operating temperature:**  
0 °C to 50 °C (32 °F to 122 °F).

**Temperature accuracy:**  
±0,3 °C (0,54 °F) typical within operating range.

**Humidity range:**  
0% to 100%.

**Humidity accuracy:**  
± 3% RH (typical within 0% to 80% RH).

**Measurement range:**  
0 to 5000ppm.

**Measurement/Transmission intervals:**  
2,5 minutes (day), 10 minutes (evening).  
Note: Battery life will be reduced should interval be shortened (i.e, using remote temperature/humidity functions).

**CO<sub>2</sub> accuracy at NTP:**  
±60 ppm +3% of reading (400 - 2,000 ppm range).

**Communication:**  
Zigbee 3,0 Green Power (encrypted, bi-directional).

**Battery voltage:**  
3,6 V.

**Battery cell:**  
AA Lithium ion.

**Battery life:**  
10+ years (non-replaceable).  
Note: Battery life can be reduced when sensor is operated at temperatures approaching the operating limits.

**Ambient temperature:**  
-30 °C to 70 °C.



Check with your local government for instruction on disposal of these products.

Unit: mm

Hotel room controller (HRC).

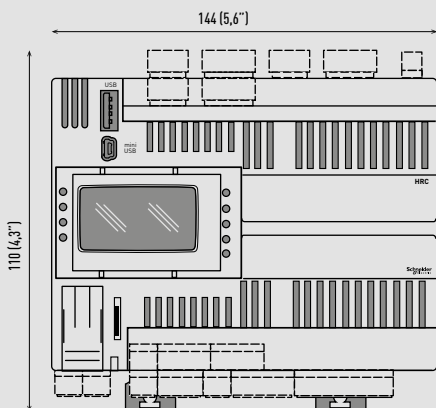

**Dimensions:**  
5,6 x 4,3 x 2,4 inches.  
144 x 110 x 60,5 mm.

**Digital inputs:**  
12.

**High voltage relay digital outputs:**  
10 x 3 A SPST +250 V AC relays.

**Analog inputs:**  
2 x configurable analog inputs.  
DI: voltage free DI, 10 kΩ input impedance.  
0-20 mA: range 0,1000, < 150 Ω impedance.  
0-10 V: range 0,1000 > 10 kΩ impedance.

**Analog outputs:**  
6 x 0-10 V outputs,  
load impedance > 700 Ω.

**Supply voltage:**  
24 V AC + 10% NOT ISOLATED.  
+20...38 V DC NOT ISOLATED.

**Supply frequency:**  
50/60 Hz.

**Power cycle:**  
35 VA / 15 W.

**Operating temperature:**  
-20 to 60 °C (-4 to 140 °F) conforming to UL 60730-1.

**Storage temperature:**  
-30 to 70 °C (-22 to 158 °F).

\* Power supply is not included.

Certification



Check with your local government for instruction on disposal of these products.

Unit: mm

CZ-CAPWFC2 Commercial Wi-Fi Adaptor.

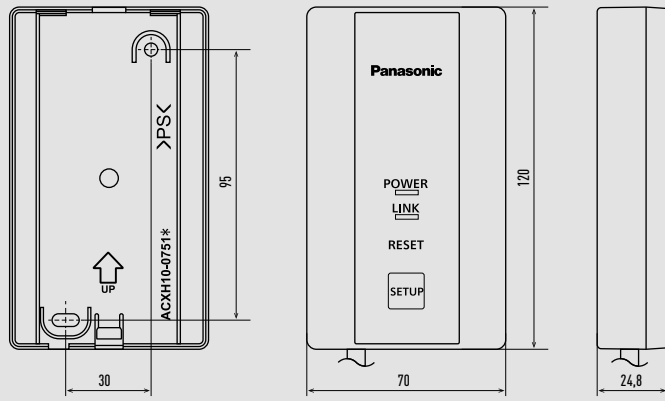

CZ-RTC6W/WBL/WBLW2 and CZ-RTC6/BL/BLW2 CONEX wired remote controller.

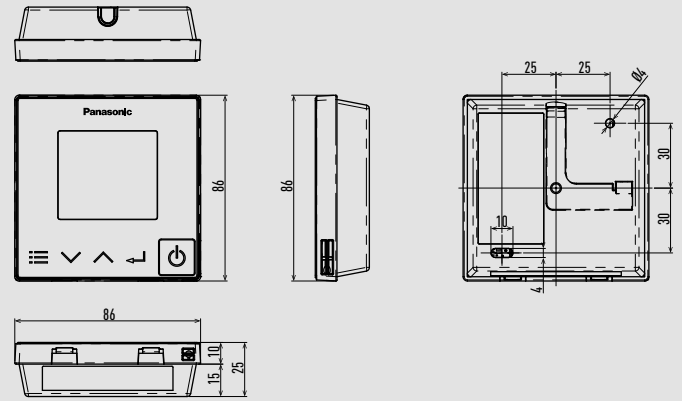

CZ-RTC5B design wired remote controller.

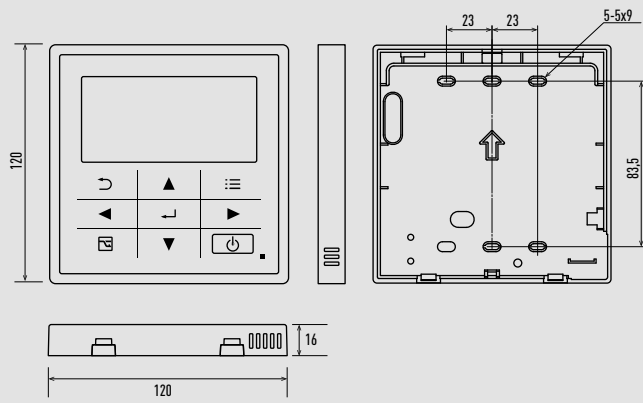

CZ-256ESMC3 intelligent controller (touch screen/web.server).

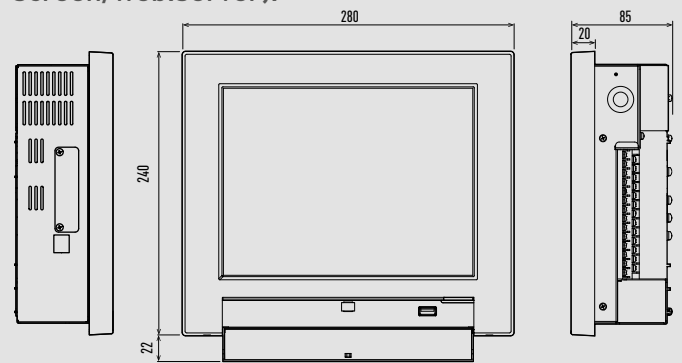

CZ-CENSC1 Econavi sensor.

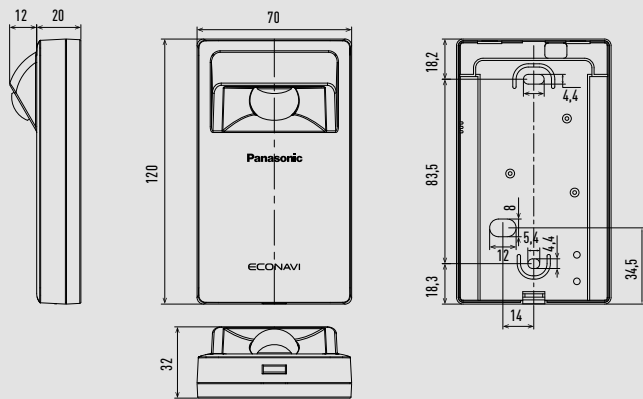

CZ-RWS3 infrared remote controller.

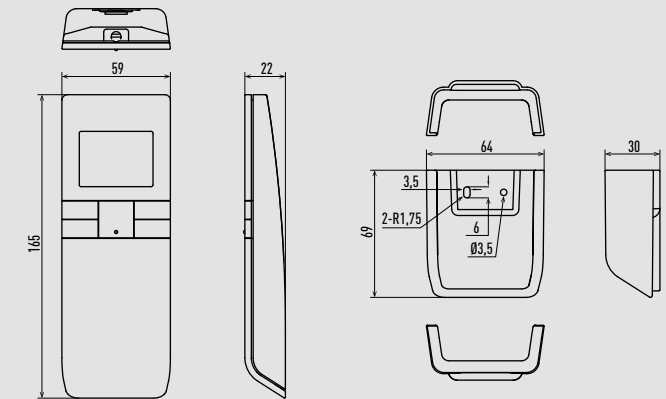

CZ-CSRC3 remote sensor.

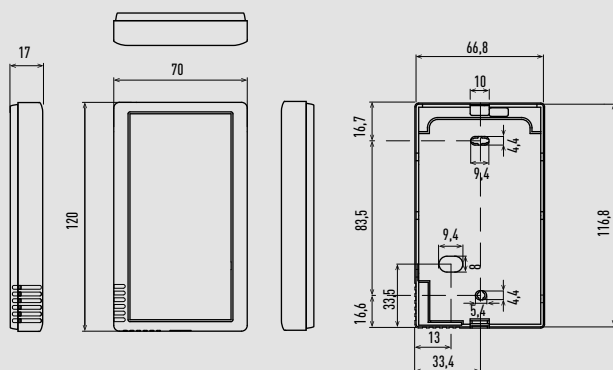

CZ-64ESMC3 system controller with weekly timer.

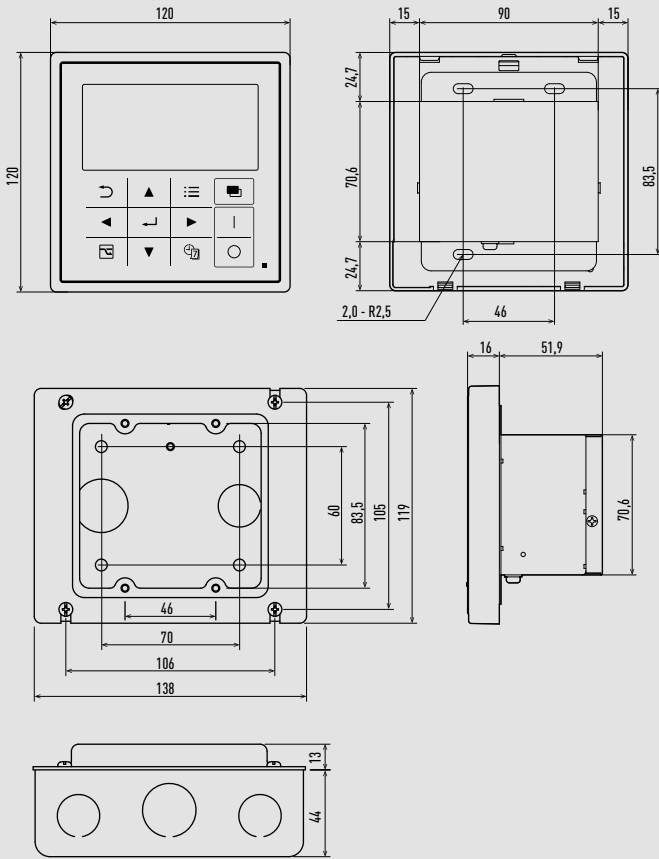

CZ-ANC3 central ON / OFF controller.

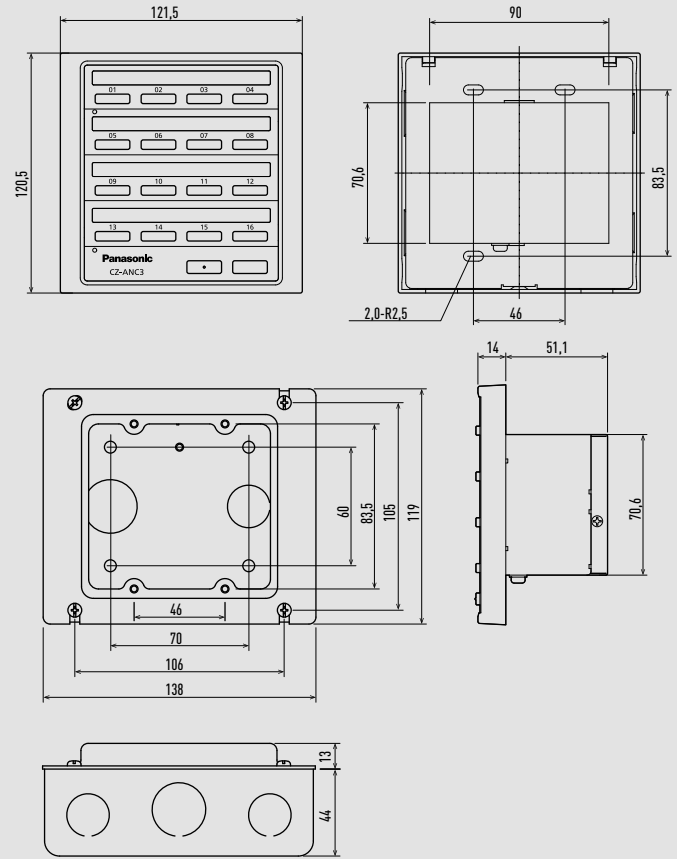

CZ-CAPC3 local adaptor for ON / OFF control.

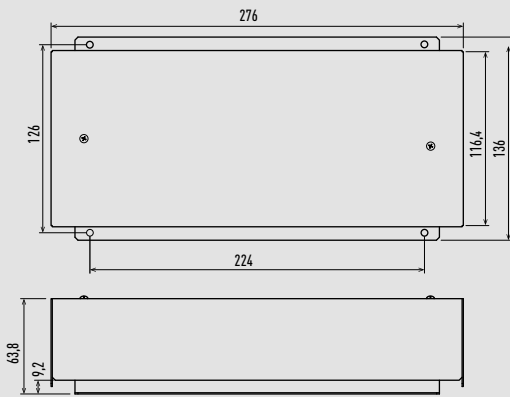

CZ-CAPBC2 Mini Seri-Para I/O Unit 0 - 10 V.

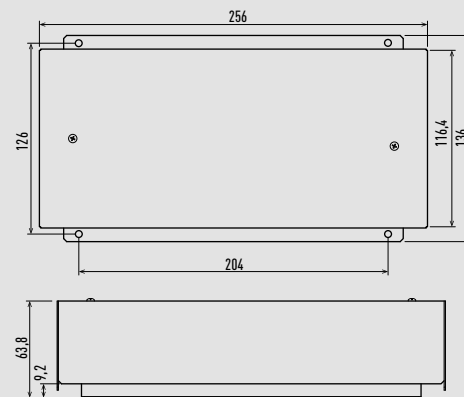

CZ-CFUNC2 communication adaptor.

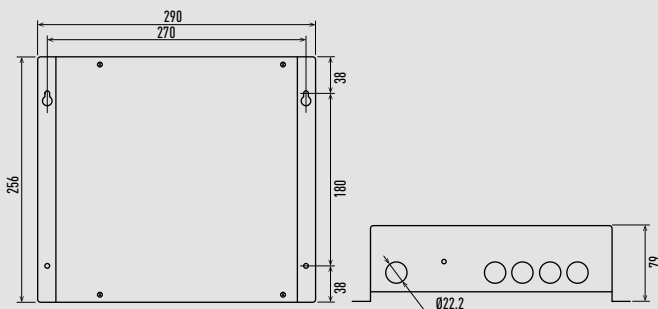

CO<sub>2</sub> condensing units - CR Series OCU-CR200VF5A / OCU-CR200VF5ASL.

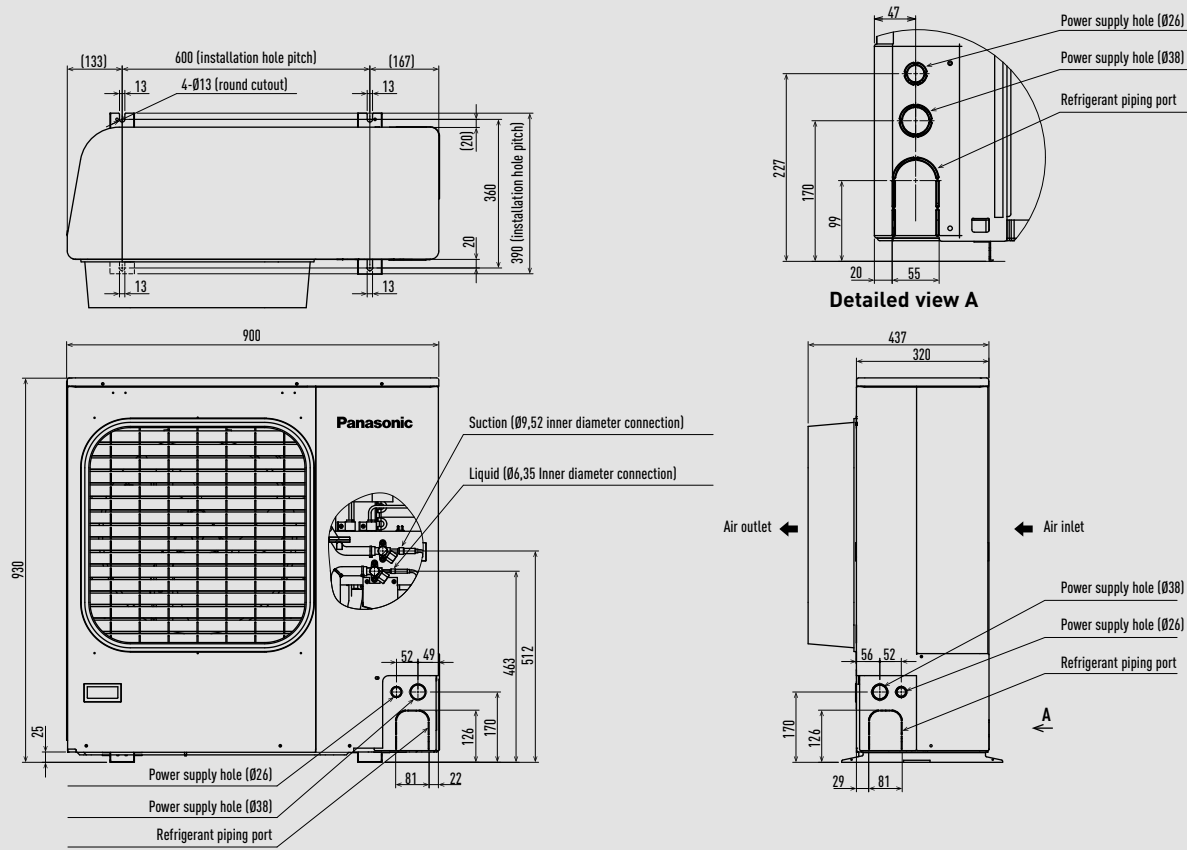

Unit: mm

CO<sub>2</sub> condensing units - CR Series OCU-CR400VF8 / OCU-CR400VF8SL / OCU-CR400VF8A / OCU-CR400VF8ASL.

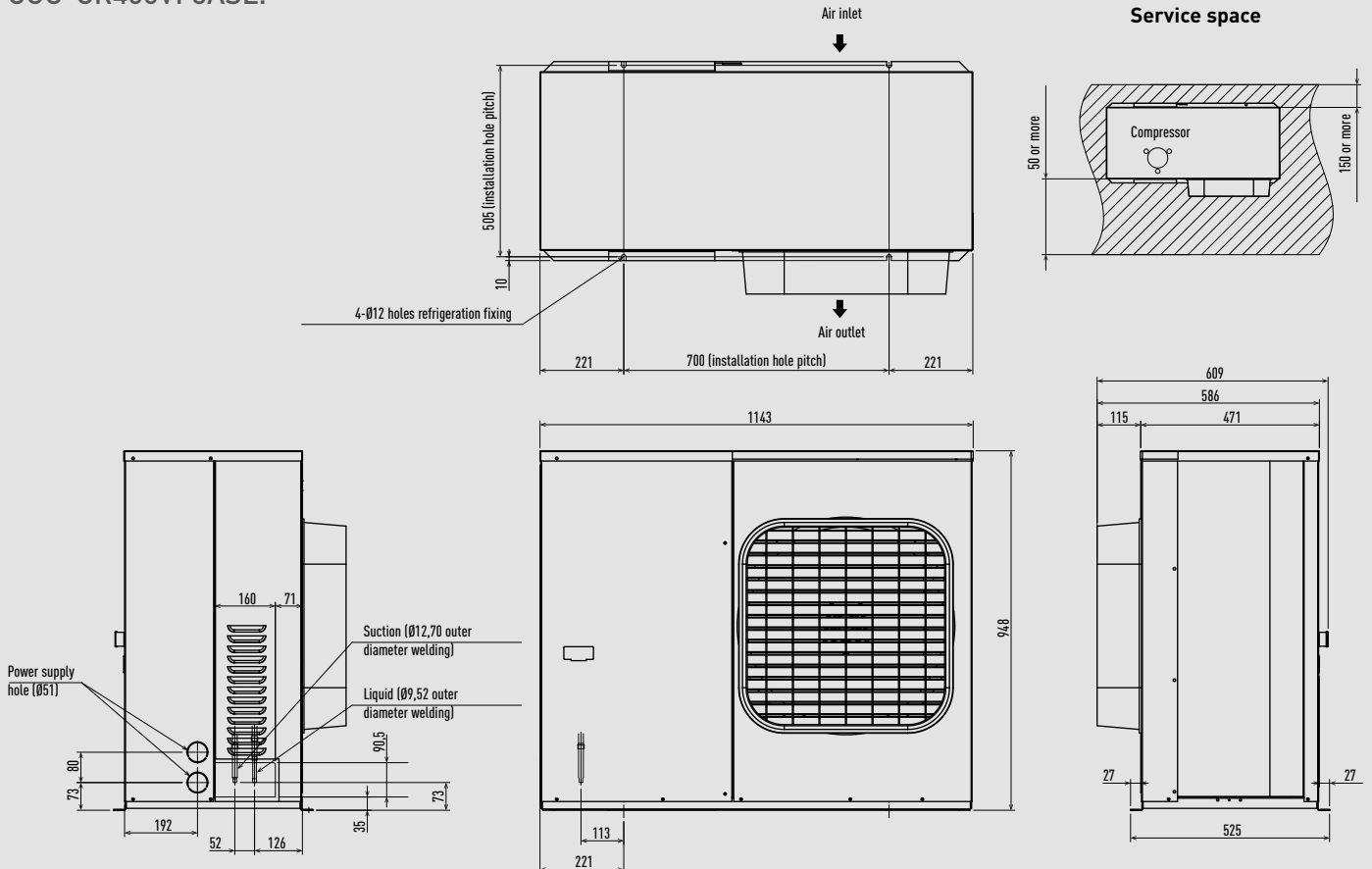

Unit: mm

CO<sub>2</sub> condensing units - CR Series OCU-CR1000VF8 / OCU-CR1000VF8SL / OCU-CR1000VF8A / OCU-CR1000VF8ASL.

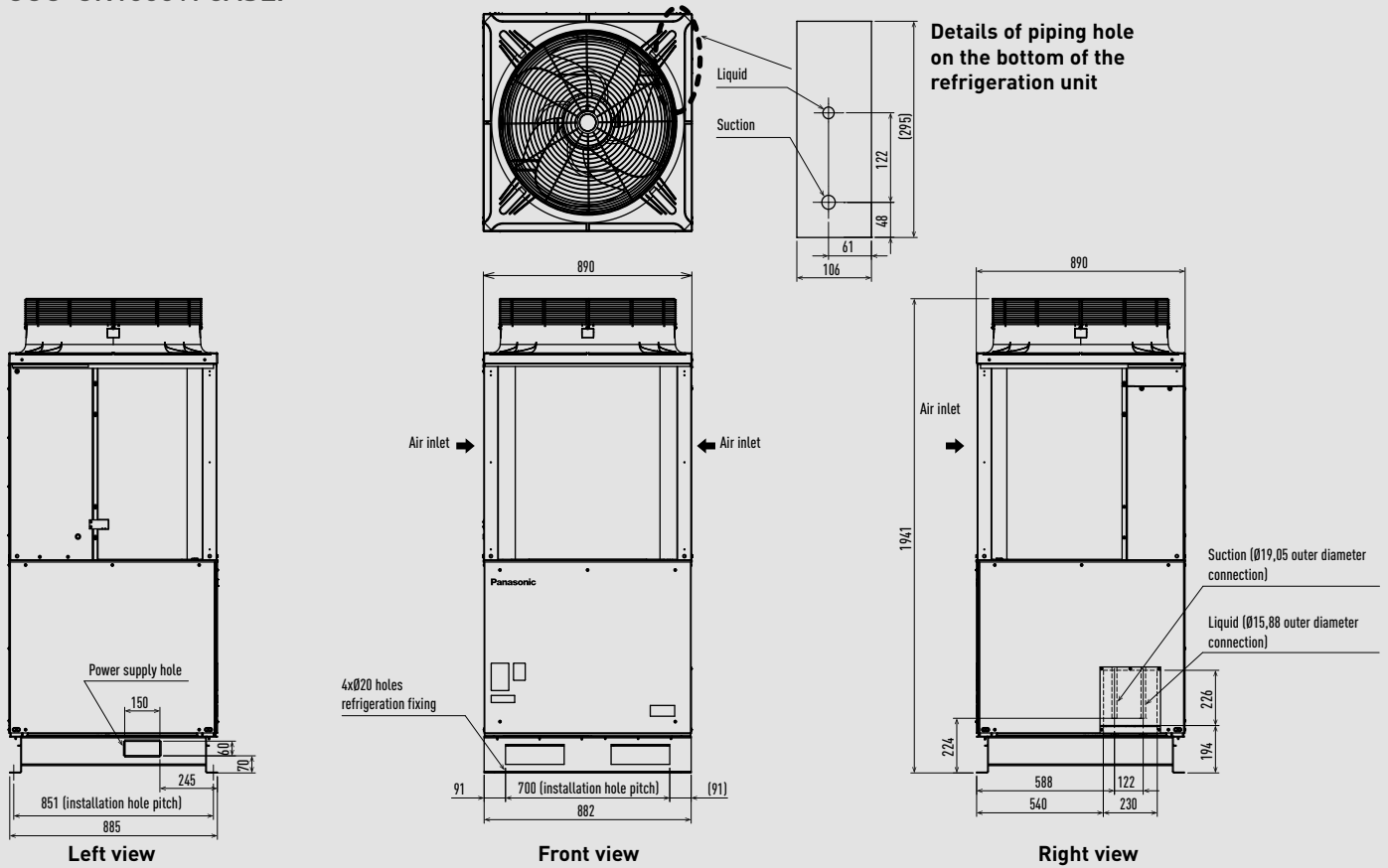

Unit: mm

CO<sub>2</sub> condensing units - CR Series OCU-CR2000VF8A / OCU-CR2000VF8ASL.

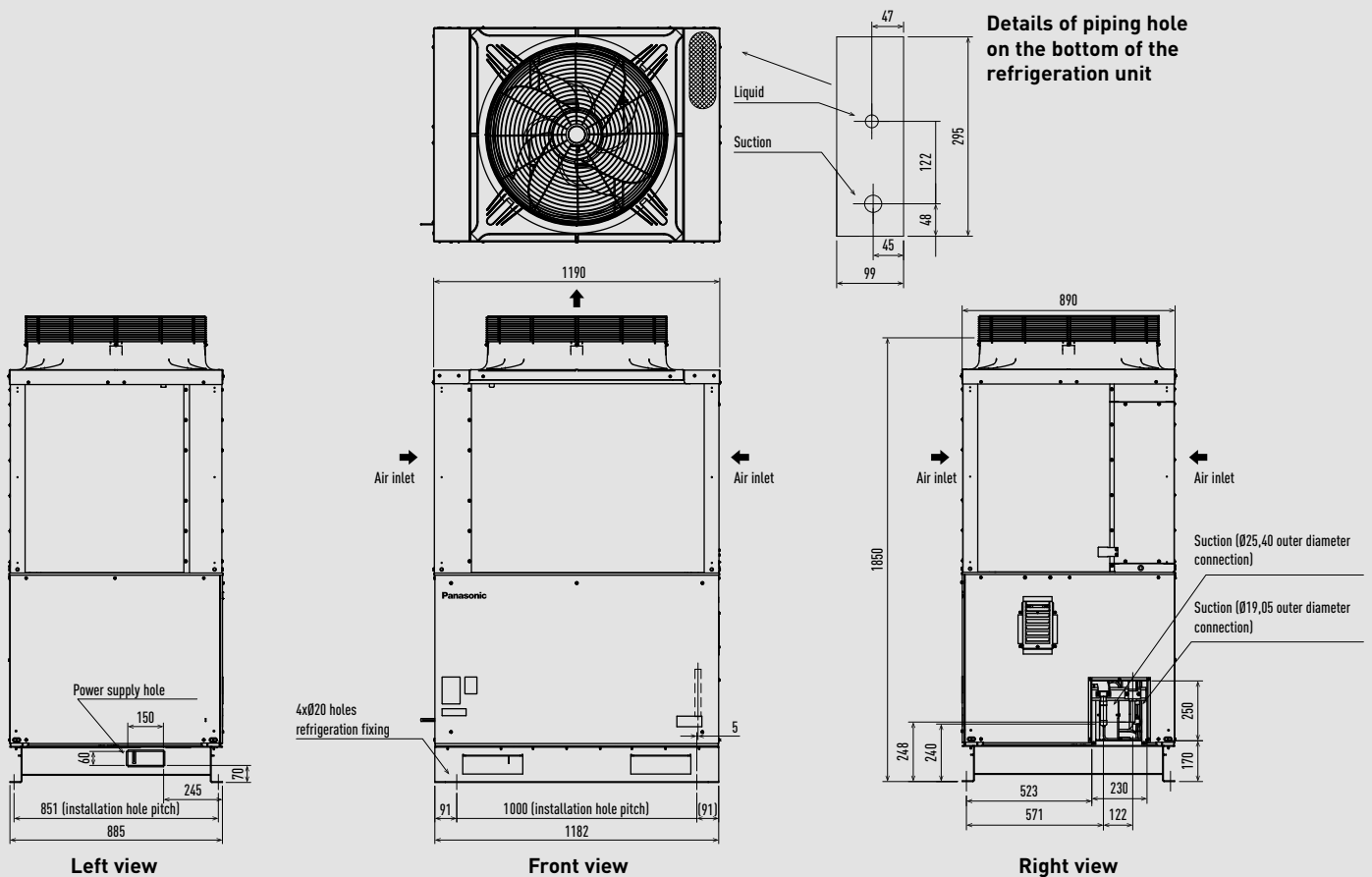

Unit: mm

# Wiring diagrams

## Domestic

Wall-mounted kits 1x1	→ 677
Floor console kits 1x1	→ 678
Low static pressure hide-away kits 1x1	→ 678
Free Multi System 2 rooms	→ 679
Free Multi System 3 rooms	→ 679
Free Multi System 4 rooms	→ 680
Free Multi System 5 rooms	→ 680

## Commercial

Wall-mounted Professional kits 1x1	→ 681
PACi NX wall-mounted kits 1x1	→ 681
PACi NX 4 way 60x60 cassette kits 1x1	→ 682
PACi NX 4 way 90x90 cassette kits 1x1	→ 682
PACi NX ceiling kits 1x1	→ 683
PACi NX adaptive ducted unit kits 1x1	→ 683
Big PACi NX hide-away kits 1x1	→ 684
Big PACi hide-away kits 1x1	→ 684
PACi NX twin system	→ 685
PACi NX triple system	→ 685
PACi NX double-twin system	→ 686
PACi twin system	→ 686
PACi triple system	→ 687
PACi double-twin system	→ 687

## VRF Systems

Mini ECOi Series	→ 688
ECOi EX and ECO G Series	→ 688
Hybrid GHP/EHP	→ 689

Please note: The wiring requirements indicated here are the minimum requirements in accordance with the installation instructions, please refer to the instructions for further details. Regulations on wire diameters and installation requirements differ from region to region. Please refer to your LOCAL ELECTRICAL CODES before commencing installation.

## Wall-mounted kits 1x1.

Indoor unit



Outdoor unit



Attention: Wall-mounted Etherea and TZ super-compact have different connection terminals



Single phase  
Power supply  
230 V / 50 Hz



Infrared remote controller (included in the delivery)

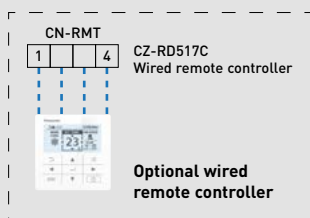

Optional wired remote controller

Power supply to indoor or outdoor depending on model, see table.

### Wall-mounted Heatcharge VZ - R32

Indoor unit	Power supply	Recommended fuse	Connection indoor / outdoor	Outdoor unit
CS-VZ9SKE	230 V (indoor)	16 A	4 x 1,5 mm <sup>2</sup>	CU-VZ9SKE
CS-VZ12SKE	230 V (indoor)	16 A	4 x 1,5 mm <sup>2</sup>	CU-VZ12SKE

### Wall-mounted Etherea Graphite grey, Silver and Matt white - R32

Indoor unit	Power supply	Recommended fuse	Power supply cable	Connection indoor / outdoor	Outdoor unit
CS-XZ20ZKEW-H / CS-XZ20ZKEW / CS-Z20ZKEW	230 V (indoor)	16 A	3 x 1,5 mm <sup>2</sup>	4 x 1,5 mm <sup>2</sup>	CU-Z20ZKE
CS-XZ25ZKEW-H / CS-XZ25ZKEW / CS-Z25ZKEW	230 V (indoor)	16 A	3 x 1,5 mm <sup>2</sup>	4 x 1,5 mm <sup>2</sup>	CU-Z25ZKE
CS-XZ35ZKEW-H / CS-XZ35ZKEW / CS-Z35ZKEW	230 V (indoor)	16 A	3 x 1,5 mm <sup>2</sup>	4 x 1,5 mm <sup>2</sup>	CU-Z35ZKE
CS-XZ42ZKEW-H / — / CS-Z42ZKEW	230 V (indoor)	16 A	3 x 1,5 mm <sup>2</sup>	4 x 1,5 mm <sup>2</sup>	CU-Z42ZKE
— / CS-XZ50ZKEW / CS-Z50ZKEW	230 V (indoor)	16 A	3 x 2,5 mm <sup>2</sup>	4 x 2,5 mm <sup>2</sup>	CU-Z50ZKE
— / — / CS-Z71ZKEW	230 V (indoor)	20 A	3 x 2,5 mm <sup>2</sup>	4 x 2,5 mm <sup>2</sup>	CU-Z71ZKE

### Wall-mounted TZ super-compact - R32

Indoor unit	Power supply	Recommended fuse	Power supply cable	Connection indoor / outdoor	Outdoor unit
CS-TZ20ZKEW	230 V (indoor)	16 A	3 x 1,5 mm <sup>2</sup>	4 x 1,5 mm <sup>2</sup>	CU-TZ20ZKE
CS-TZ25ZKEW	230 V (indoor)	16 A	3 x 1,5 mm <sup>2</sup>	4 x 1,5 mm <sup>2</sup>	CU-TZ25ZKE
CS-TZ35ZKEW	230 V (indoor)	16 A	3 x 1,5 mm <sup>2</sup>	4 x 1,5 mm <sup>2</sup>	CU-TZ35ZKE
CS-TZ42ZKEW	230 V (indoor)	16 A	3 x 1,5 mm <sup>2</sup>	4 x 1,5 mm <sup>2</sup>	CU-TZ42ZKE
CS-TZ50ZKEW	230 V (indoor)	16 A	3 x 2,5 mm <sup>2</sup>	4 x 2,5 mm <sup>2</sup>	CU-TZ50ZKE
CS-TZ60ZKEW	230 V (indoor)	20 A	3 x 2,5 mm <sup>2</sup>	4 x 2,5 mm <sup>2</sup>	CU-TZ60ZKE
CS-TZ71ZKEW	230 V (indoor)	20 A	3 x 2,5 mm <sup>2</sup>	4 x 2,5 mm <sup>2</sup>	CU-TZ71ZKE

### Wall-mounted BZ super-compact - R32

Indoor unit	Power supply	Recommended fuse	Power supply cable	Connection indoor / outdoor	Outdoor unit
CS-BZ25ZKE	230 V (indoor)	16 A	3 x 1,5 mm <sup>2</sup>	4 x 1,5 mm <sup>2</sup>	CU-BZ25ZKE
CS-BZ35ZKE	230 V (indoor)	16 A	3 x 1,5 mm <sup>2</sup>	4 x 1,5 mm <sup>2</sup>	CU-BZ35ZKE
CS-BZ50ZKE	230 V (indoor)	16 A	3 x 2,5 mm <sup>2</sup>	4 x 2,5 mm <sup>2</sup>	CU-BZ50ZKE
CS-BZ60ZKE	230 V (indoor)	20 A	3 x 2,5 mm <sup>2</sup>	4 x 2,5 mm <sup>2</sup>	CU-BZ60ZKE

### Wall-mounted UZ super-compact - R32

Indoor unit	Power supply	Recommended fuse	Power supply cable	Connection indoor / outdoor	Outdoor unit
CS-UZ25WKE	230 V (indoor)	16 A	3 x 1,5 mm <sup>2</sup>	4 x 1,5 mm <sup>2</sup>	CU-UZ25WKE
CS-UZ35WKE	230 V (indoor)	16 A	3 x 1,5 mm <sup>2</sup>	4 x 1,5 mm <sup>2</sup>	CU-UZ35WKE
CS-UZ50WKE	230 V (indoor)	16 A	3 x 2,5 mm <sup>2</sup>	4 x 2,5 mm <sup>2</sup>	CU-UZ50WKE

### Floor console kits 1x1.

Indoor unit



Infrared remote controller (included in the delivery)

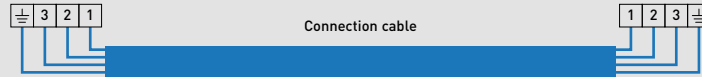

Outdoor unit



Single phase Power supply 230 V / 50 Hz

#### Floor console - R32

Indoor unit	Power supply	Recommended fuse	Power supply cable	Connection indoor / outdoor	Outdoor unit
CS-Z25UFEAW	230 V (outdoor)	16 A	3 x 1,5 mm <sup>2</sup>	4 x 1,5 mm <sup>2</sup>	CU-Z25UBEA
CS-Z35UFEAW	230 V (outdoor)	16 A	3 x 1,5 mm <sup>2</sup>	4 x 1,5 mm <sup>2</sup>	CU-Z35UBEA
CS-Z50UFEAW	230 V (outdoor)	16 A	3 x 2,5 mm <sup>2</sup>	4 x 2,5 mm <sup>2</sup>	CU-Z50UBEA

### Low static pressure hide-away kits 1x1.

Indoor unit



CN-DISP CZ-RD52CP Included wired remote controller



Outdoor unit



Single phase Power supply 230 V / 50 Hz

#### Low static pressure hide-away - R32

Indoor unit	Power supply	Recommended fuse	Power supply cable	Connection indoor / outdoor	Outdoor unit
CS-Z25UD3EAW	230 V (outdoor)	16 A	3 x 1,5 mm <sup>2</sup>	4 x 1,5 mm <sup>2</sup>	CU-Z25UBEA
CS-Z35UD3EAW	230 V (outdoor)	16 A	3 x 1,5 mm <sup>2</sup>	4 x 1,5 mm <sup>2</sup>	CU-Z35UBEA
CS-Z50UD3EAW	230 V (outdoor)	16 A	3 x 2,5 mm <sup>2</sup>	4 x 1,5 mm <sup>2</sup>	CU-Z50UBEA
CS-Z60UD3EAW	230 V (outdoor)	16 A	3 x 2,5 mm <sup>2</sup>	4 x 1,5 mm <sup>2</sup>	CU-Z60UBEA

### Free Multi System 2 rooms.

Indoor unit

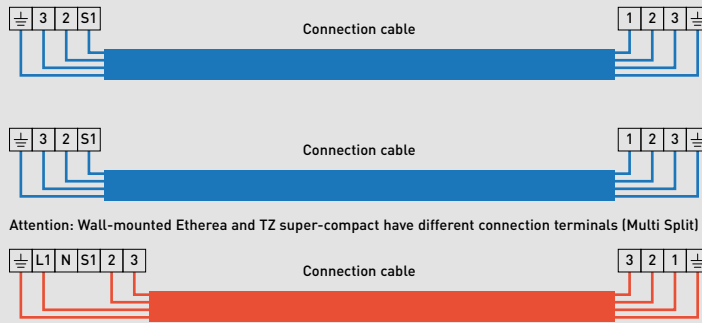
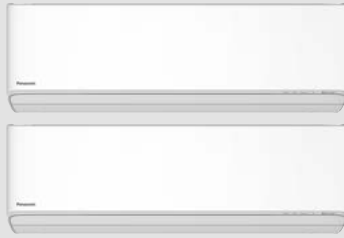

Attention: Wall-mounted Etherea and TZ super-compact have different connection terminals (Multi Split)

Outdoor unit



Single phase  
Power supply  
230 V / 50 Hz / 16 A

#### Free Multi System - R32

Outdoor unit	Power supply	Recommended fuse	Power supply cable	Connection indoor / outdoor
CU-2Z35TBE	230 V	16 A	3 x 1,5 mm <sup>2</sup>	4 x 1,5 mm <sup>2</sup>
CU-2Z41TBE	230 V	16 A	3 x 1,5 mm <sup>2</sup>	4 x 1,5 mm <sup>2</sup>
CU-2Z50TBE	230 V	16 A	3 x 1,5 mm <sup>2</sup>	4 x 1,5 mm <sup>2</sup>
CU-2TZ41TBE	230 V	16 A	3 x 1,5 mm <sup>2</sup>	4 x 1,5 mm <sup>2</sup>
CU-2TZ50TBE	230 V	16 A	3 x 1,5 mm <sup>2</sup>	4 x 1,5 mm <sup>2</sup>

### Free Multi System 3 rooms.

Indoor unit

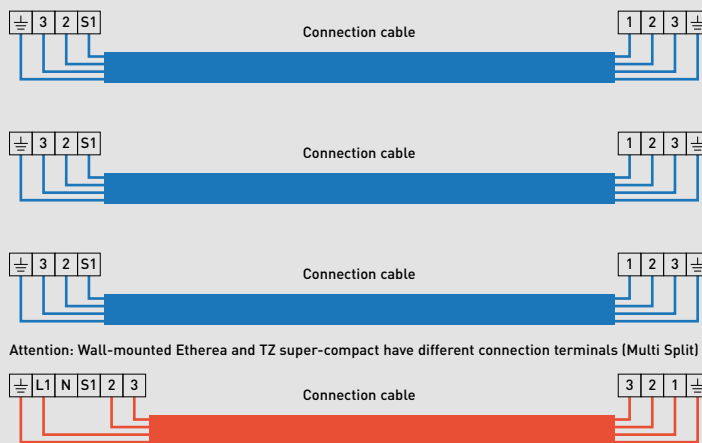

Attention: Wall-mounted Etherea and TZ super-compact have different connection terminals (Multi Split)

Outdoor unit



Single phase  
Power supply  
230 V / 50 Hz / 16 A

#### Free Multi System - R32

Outdoor unit	Power supply	Recommended fuse	Power supply cable	Connection indoor / outdoor
CU-3Z52TBE	230 V	16 A	3 x 2,5 mm <sup>2</sup>	4 x 1,5 mm <sup>2</sup>
CU-3Z68TBE	230 V	16 A	3 x 2,5 mm <sup>2</sup>	4 x 1,5 mm <sup>2</sup>
CU-3TZ52TBE	230 V	16 A	3 x 2,5 mm <sup>2</sup>	4 x 1,5 mm <sup>2</sup>

### Free Multi System 4 rooms.

Indoor unit

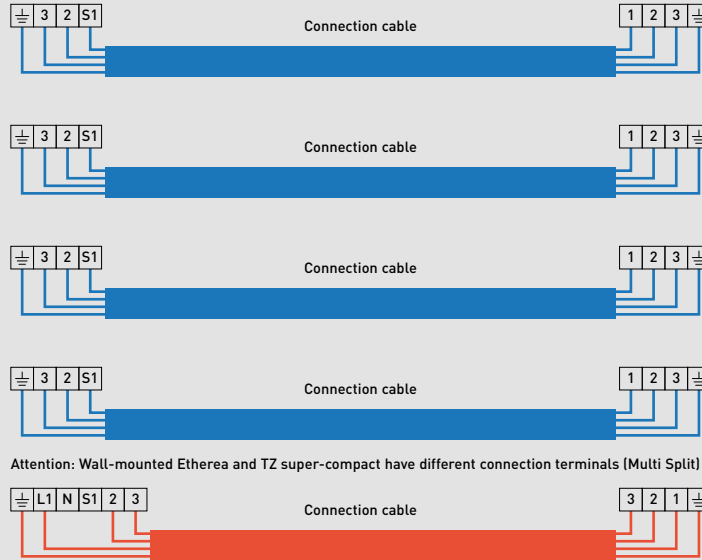

Attention: Wall-mounted Etherea and TZ super-compact have different connection terminals (Multi Split)

Outdoor unit

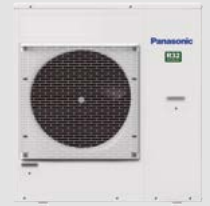

Single phase  
Power supply  
230 V / 50 Hz / 20 A

### Free Multi System · R32

Outdoor unit	Power supply	Recommended fuse	Power supply cable	Connection indoor / outdoor
CU-4Z68TBE	230 V	20 A	3 x 2,5 mm <sup>2</sup>	4 x 1,5 mm <sup>2</sup>
CU-4Z80TBE	230 V	20 A	3 x 2,5 mm <sup>2</sup>	4 x 1,5 mm <sup>2</sup>

### Free Multi System 5 rooms.

Indoor unit

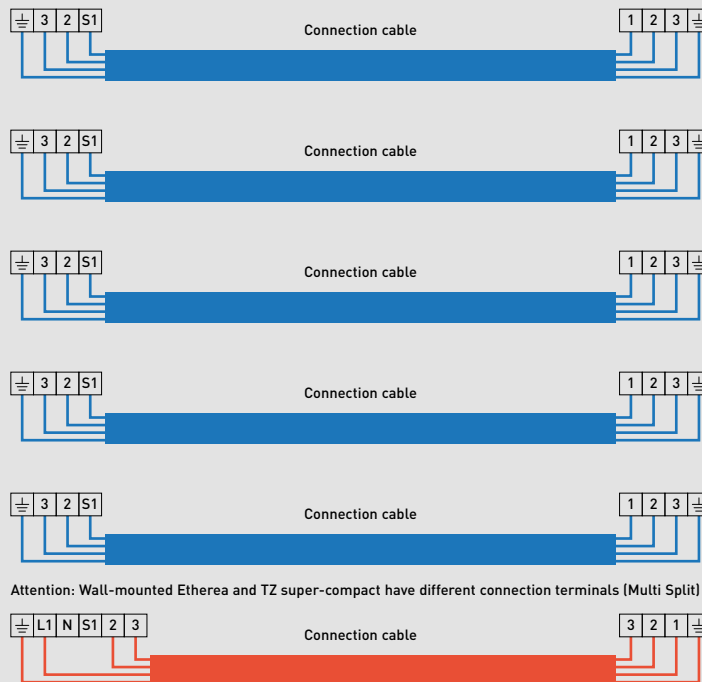

Attention: Wall-mounted Etherea and TZ super-compact have different connection terminals (Multi Split)

Outdoor unit

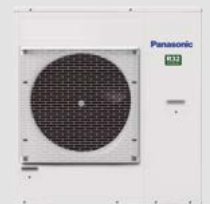

Single phase  
Power supply  
230 V / 50 Hz / 25 A

### Free Multi System · R32

Outdoor unit	Power supply	Recommended fuse	Power supply cable	Connection indoor / outdoor
CU-5Z90TBE	230 V	25 A	3 x 4,0 mm <sup>2</sup>	4 x 1,5 mm <sup>2</sup>

### Wall-mounted Professional kits 1x1.

Indoor unit

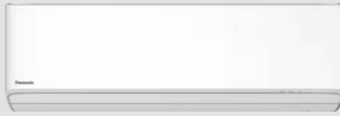

Outdoor unit

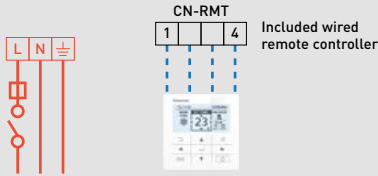
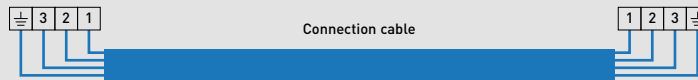

Single phase  
Power supply  
230 V / 50 Hz

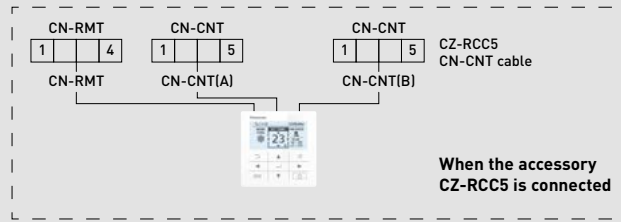

### Wall-mounted Professional -25 °C · R32

Indoor unit	Power supply	Recommended fuse	Connection indoor / outdoor	Outdoor unit
CS-Z25YKEA-1	230 V (indoor)	16 A	4 x 1,5 mm <sup>2</sup>	CU-Z25YKEA-1
CS-Z35YKEA-1	230 V (indoor)	16 A	4 x 1,5 mm <sup>2</sup>	CU-Z35YKEA-1
CS-Z42YKEA-1	230 V (indoor)	16 A	4 x 1,5 mm <sup>2</sup>	CU-Z42YKEA-1
CS-Z50YKEA-1	230 V (indoor)	16 A	4 x 2,5 mm <sup>2</sup>	CU-Z50YKEA-1
CS-Z71YKEA-1	230 V (indoor)	20 A	4 x 2,5 mm <sup>2</sup>	CU-Z71YKEA-1

### PACi NX wall-mounted kits 1x1.

Indoor unit

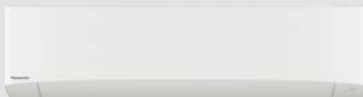

Outdoor unit

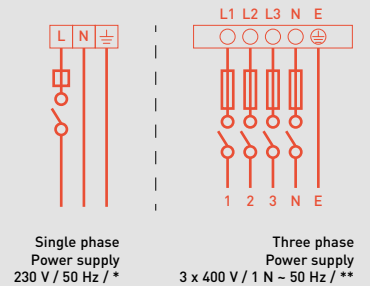
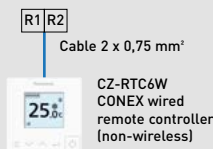

#### Single phase

Indoor unit	Connection indoor / outdoor	Outdoor unit	Power supply	Circuit breaker*
S-3650PK3E	4 x 1,5 mm <sup>2</sup>	U-36PZH3E5	220 / 230 / 240V	20 A
S-3650PK3E	4 x 1,5 mm <sup>2</sup>	U-50PZH3E5		20 A
S-6010PK3E	4 x 1,5 mm <sup>2</sup>	U-60PZH3E5		25 A
S-6010PK3E	4 x 2,5 mm <sup>2</sup>	U-71PZH4E5		25 A
S-6010PK3E	4 x 2,5 mm <sup>2</sup>	U-100PZH4E5		35 A
S-6010PK3E	4 x 1,5 mm <sup>2</sup>	U-36PZ3E5		16 A
S-6010PK3E	4 x 1,5 mm <sup>2</sup>	U-50PZ3E5		16 A
S-6010PK3E	4 x 1,5 mm <sup>2</sup>	U-60PZ3E5A		20 A
S-6010PK3E	4 x 1,5 mm <sup>2</sup>	U-71PZ3E5A		20 A
S-6010PK3E	4 x 2,5 mm <sup>2</sup>	U-100PZ3E5		35 A

#### Three phase

Indoor unit	Connection indoor / outdoor	Outdoor unit	Power supply	Circuit breaker**
S-6010PK3E	4 x 2,5 mm <sup>2</sup>	U-71PZH4E8	380 / 400 / 415V	16 A
S-6010PK3E	4 x 2,5 mm <sup>2</sup>	U-100PZH4E8		16 A
S-6010PK3E	4 x 2,5 mm <sup>2</sup>	U-100PZ3E8		16 A

### PACi NX 4 way 60x60 cassette kits 1x1.

Indoor unit

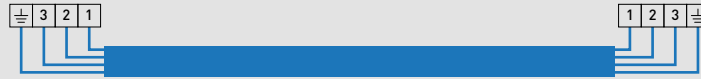

Outdoor unit

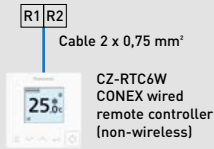

Single phase  
Power supply  
230 V / 50 Hz / 16 A

#### Single phase

Indoor unit	Connection indoor / outdoor	Outdoor unit	Power supply	Circuit breaker
S-36PY3E	4 x 1,5 mm <sup>2</sup>	U-36PZH3E5	220/230/240 V	20 A
S-50PY3E	4 x 1,5 mm <sup>2</sup>	U-50PZH3E5		20 A
S-60PY3E	4 x 1,5 mm <sup>2</sup>	U-60PZH3E5		20 A
S-25PY3E	4 x 1,5 mm <sup>2</sup>	U-25PZ3E5		16 A
S-36PY3E	4 x 1,5 mm <sup>2</sup>	U-36PZ3E5		16 A
S-50PY3E	4 x 1,5 mm <sup>2</sup>	U-50PZ3E5		16 A
S-60PY3E	4 x 1,5 mm <sup>2</sup>	U-60PZ3E5A		20 A

### PACi NX 4 way 90x90 cassette kits 1x1.

Indoor unit



Outdoor unit

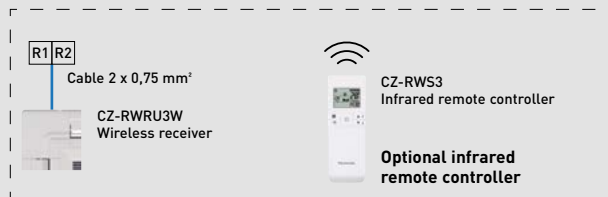
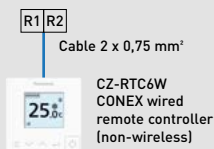

Single phase  
Power supply  
230 V / 50 Hz / \*

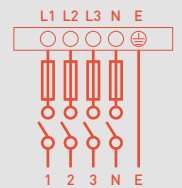

Three phase  
Power supply  
3 x 400 V / 1 N - 50 Hz / \*\*

#### Single phase

Indoor unit	Connection indoor / outdoor	Outdoor unit	Power supply	Circuit breaker*
S-3650PU3E	4 x 1,5 mm <sup>2</sup>	U-36PZH3E5	220/230/240 V	20 A
S-3650PU3E	4 x 1,5 mm <sup>2</sup>	U-50PZH3E5		20 A
S-6071PU3E	4 x 1,5 mm <sup>2</sup>	U-60PZH3E5		25 A
S-6071PU3E	4 x 2,5 mm <sup>2</sup>	U-71PZH4E5		25 A
S-1014PU3E	4 x 2,5 mm <sup>2</sup>	U-100PZH4E5		35 A
S-1014PU3E	4 x 2,5 mm <sup>2</sup>	U-125PZH4E5		40 A
S-1014PU3E	4 x 2,5 mm <sup>2</sup>	U-140PZH4E5		40 A
S-3650PU3E	4 x 1,5 mm <sup>2</sup>	U-36PZ3E5		16 A
S-3650PU3E	4 x 1,5 mm <sup>2</sup>	U-50PZ3E5		16 A
S-6071PU3E	4 x 1,5 mm <sup>2</sup>	U-60PZ3E5A		20 A
S-6071PU3E	4 x 1,5 mm <sup>2</sup>	U-71PZ3E5A		20 A
S-6010PU3E	4 x 2,5 mm <sup>2</sup>	U-100PZ3E5		35 A
S-1014PU3E	4 x 2,5 mm <sup>2</sup>	U-125PZ3E5		40 A
S-1014PU3E	4 x 2,5 mm <sup>2</sup>	U-140PZ3E5		40 A

#### Three phase

Indoor unit	Connection indoor / outdoor	Outdoor unit	Power supply	Circuit breaker**
S-6071PU3E	4 x 2,5 mm <sup>2</sup>	U-71PZH4E8	380/400/415 V	16 A
S-1014PU3E	4 x 2,5 mm <sup>2</sup>	U-100PZH4E8		16 A
S-1014PU3E	4 x 2,5 mm <sup>2</sup>	U-125PZH4E8		16 A
S-1014PU3E	4 x 2,5 mm <sup>2</sup>	U-140PZH4E8		16 A
S-1014PU3E	4 x 2,5 mm <sup>2</sup>	U-100PZ3E8		16 A
S-1014PU3E	4 x 2,5 mm <sup>2</sup>	U-125PZ3E8		20 A
S-1014PU3E	4 x 2,5 mm <sup>2</sup>	U-140PZ3E8		20 A

### PACi NX ceiling kits 1x1.

Indoor unit

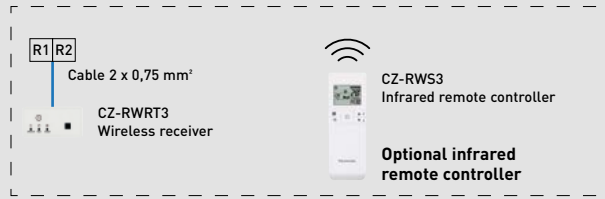
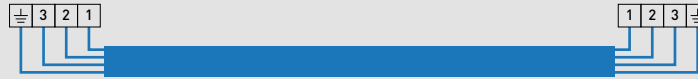
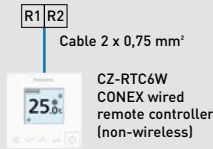

Outdoor unit

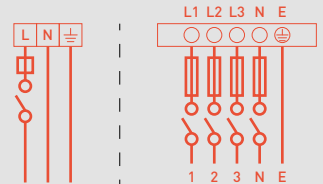

Single phase  
Power supply  
230 V / 50 Hz / \*

Three phase  
Power supply  
3 x 400 V / 1 N - 50 Hz / \*\*

#### Single phase

Indoor unit	Connection indoor / outdoor	Outdoor unit	Power supply	Circuit breaker*
S-3650PT3E	4 x 1,5 mm <sup>2</sup>	U-36PZH3E5	220 / 230 / 240 V	20 A
S-3650PT3E	4 x 1,5 mm <sup>2</sup>	U-50PZH3E5		20 A
S-6071PT3E	4 x 1,5 mm <sup>2</sup>	U-60PZH3E5		25 A
S-6071PT3E	4 x 2,5 mm <sup>2</sup>	U-71PZH4E5		25 A
S-1014PT3E	4 x 2,5 mm <sup>2</sup>	U-100PZH4E5		35 A
S-1014PT3E	4 x 2,5 mm <sup>2</sup>	U-125PZH4E5		40 A
S-1014PT3E	4 x 2,5 mm <sup>2</sup>	U-140PZH4E5		40 A
S-3650PT3E	4 x 1,5 mm <sup>2</sup>	U-36PZ3E5		16 A
S-3650PT3E	4 x 1,5 mm <sup>2</sup>	U-50PZ3E5		16 A
S-6071PT3E	4 x 1,5 mm <sup>2</sup>	U-60PZ3E5A		20 A
S-6071PT3E	4 x 1,5 mm <sup>2</sup>	U-71PZ3E5A		20 A
S-6010PT3E	4 x 2,5 mm <sup>2</sup>	U-100PZ3E5		35 A
S-1014PT3E	4 x 2,5 mm <sup>2</sup>	U-125PZ3E5		40 A
S-1014PT3E	4 x 2,5 mm <sup>2</sup>	U-140PZ3E5		40 A

#### Three phase

Indoor unit	Connection indoor / outdoor	Outdoor unit	Power supply	Circuit breaker**
S-6071PT3E	4 x 2,5 mm <sup>2</sup>	U-71PZH4E8	380 / 400 / 415 V	16 A
S-1014PT3E	4 x 2,5 mm <sup>2</sup>	U-100PZH4E8		16 A
S-1014PT3E	4 x 2,5 mm <sup>2</sup>	U-125PZH4E8		16 A
S-1014PT3E	4 x 2,5 mm <sup>2</sup>	U-140PZH4E8		16 A
S-1014PT3E	4 x 2,5 mm <sup>2</sup>	U-100PZ3E8		16 A
S-1014PT3E	4 x 2,5 mm <sup>2</sup>	U-125PZ3E8		20 A
S-1014PT3E	4 x 2,5 mm <sup>2</sup>	U-140PZ3E8		20 A

### PACi NX adaptive ducted unit kits 1x1.

Indoor unit

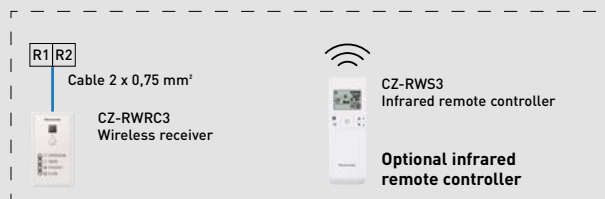
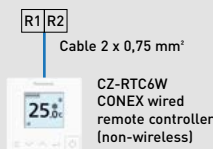

Outdoor unit

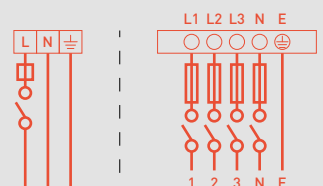

Single phase  
Power supply  
230 V / 50 Hz / \*

Three phase  
Power supply  
3 x 400 V / 1 N - 50 Hz / \*\*

#### Single phase

Indoor unit	Connection indoor / outdoor	Outdoor unit	Power supply	Circuit breaker*
S-3650PF3E	4 x 1,5 mm <sup>2</sup>	U-36PZH3E5	220 / 230 / 240 V	20 A
S-3650PF3E	4 x 1,5 mm <sup>2</sup>	U-50PZH3E5		20 A
S-6071PF3E	4 x 1,5 mm <sup>2</sup>	U-60PZH3E5		25 A
S-6071PF3E	4 x 2,5 mm <sup>2</sup>	U-71PZH4E5		25 A
S-1014PF3E	4 x 2,5 mm <sup>2</sup>	U-100PZH4E5		35 A
S-1014PF3E	4 x 2,5 mm <sup>2</sup>	U-125PZH4E5		40 A
S-1014PF3E	4 x 2,5 mm <sup>2</sup>	U-140PZH4E5		40 A
S-3650PF3E	4 x 1,5 mm <sup>2</sup>	U-36PZ3E5		16 A
S-3650PF3E	4 x 1,5 mm <sup>2</sup>	U-50PZ3E5		16 A
S-6071PF3E	4 x 1,5 mm <sup>2</sup>	U-60PZ3E5A		20 A
S-6071PF3E	4 x 1,5 mm <sup>2</sup>	U-71PZ3E5A		20 A
S-6010PF3E	4 x 2,5 mm <sup>2</sup>	U-100PZ3E5		35 A
S-1014PF3E	4 x 2,5 mm <sup>2</sup>	U-125PZ3E5		40 A
S-1014PF3E	4 x 2,5 mm <sup>2</sup>	U-140PZ3E5		40 A

#### Three phase

Indoor unit	Connection indoor / outdoor	Outdoor unit	Power supply	Circuit breaker**
S-6071PF3E	4 x 2,5 mm <sup>2</sup>	U-71PZH4E8	380 / 400 / 415 V	16 A
S-1014PF3E	4 x 2,5 mm <sup>2</sup>	U-100PZH4E8		16 A
S-1014PF3E	4 x 2,5 mm <sup>2</sup>	U-125PZH4E8		16 A
S-1014PF3E	4 x 2,5 mm <sup>2</sup>	U-140PZH4E8		16 A
S-1014PF3E	4 x 2,5 mm <sup>2</sup>	U-100PZ3E8		16 A
S-1014PF3E	4 x 2,5 mm <sup>2</sup>	U-125PZ3E8		20 A
S-1014PF3E	4 x 2,5 mm <sup>2</sup>	U-140PZ3E8		20 A

### Big PACi NX high static pressure hide-away 20,0-25,0 kW kits 1x1.

Indoor unit

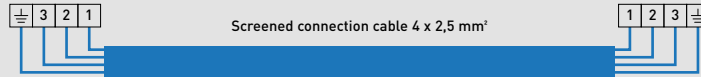

Outdoor unit

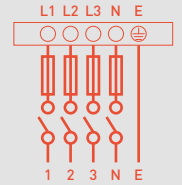
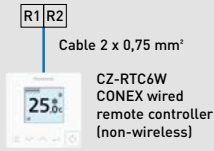

Three phase  
Power supply  
3 x 400 V / 1 N - 50 Hz

#### Three phase

Indoor unit	Outdoor unit	Power supply	Circuit breaker
S-200PE4E	U-200PZH4E8	380/400/415 V	20 A
S-250PE4E	U-250PZH4E8		25 A

### Big PACi high static pressure hide-away 20,0-25,0 kW kits 1x1.

Indoor unit

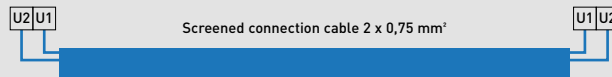

Outdoor unit

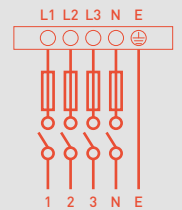
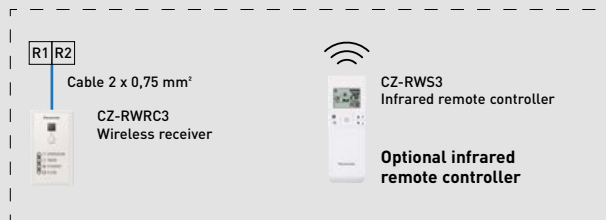
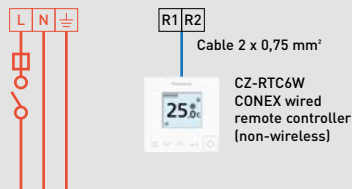

Single phase  
Power supply  
230 V / 50 Hz / 10 A

Three phase  
Power supply  
3 x 400 V / 1 N - 50 Hz

#### Three phase

Indoor unit	Power supply	Outdoor unit	Power supply	Circuit breaker
S-200PE3E5B	220/230/240 V	U-200PZH2E8	380/400/415 V	30 A
S-250PE3E5B		U-250PZH2E8		30 A

PACi NX twin system.

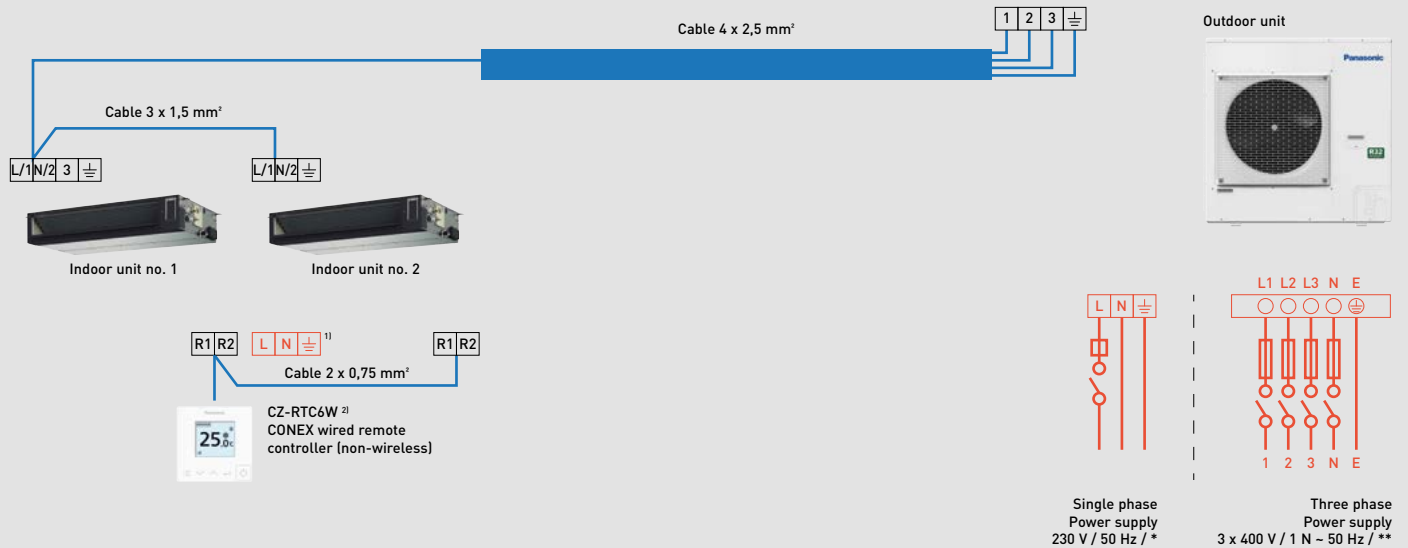

Single phase

Outdoor unit	Power supply	Circuit breaker*
U-71PZH4E5	220 / 230 / 240 V	25 A
U-100PZH4E5		35 A
U-125PZH4E5		40 A
U-140PZH4E5		40 A
U-100PZ3E5		35 A
U-125PZ3E5		40 A
U-140PZ3E5		40 A

1) Optional connection of single phase power supply connection to unit no. 2. Please refer to installation instructions for details. 2) Optional infrared remote controller is also possible. Wireless receivers may be required depending on indoor units.

Three phase

Outdoor unit	Power supply	Circuit breaker**
U-71PZH4E8	380 / 400 / 415 V	16 A
U-100PZH4E8		16 A
U-125PZH4E8		16 A
U-140PZH4E8		16 A
U-200PZH4E8		20 A
U-250PZH4E8		30 A
U-100PZ3E8		16 A
U-125PZ3E8	20 A	
U-140PZ3E8	20 A	

PACi NX triple system.

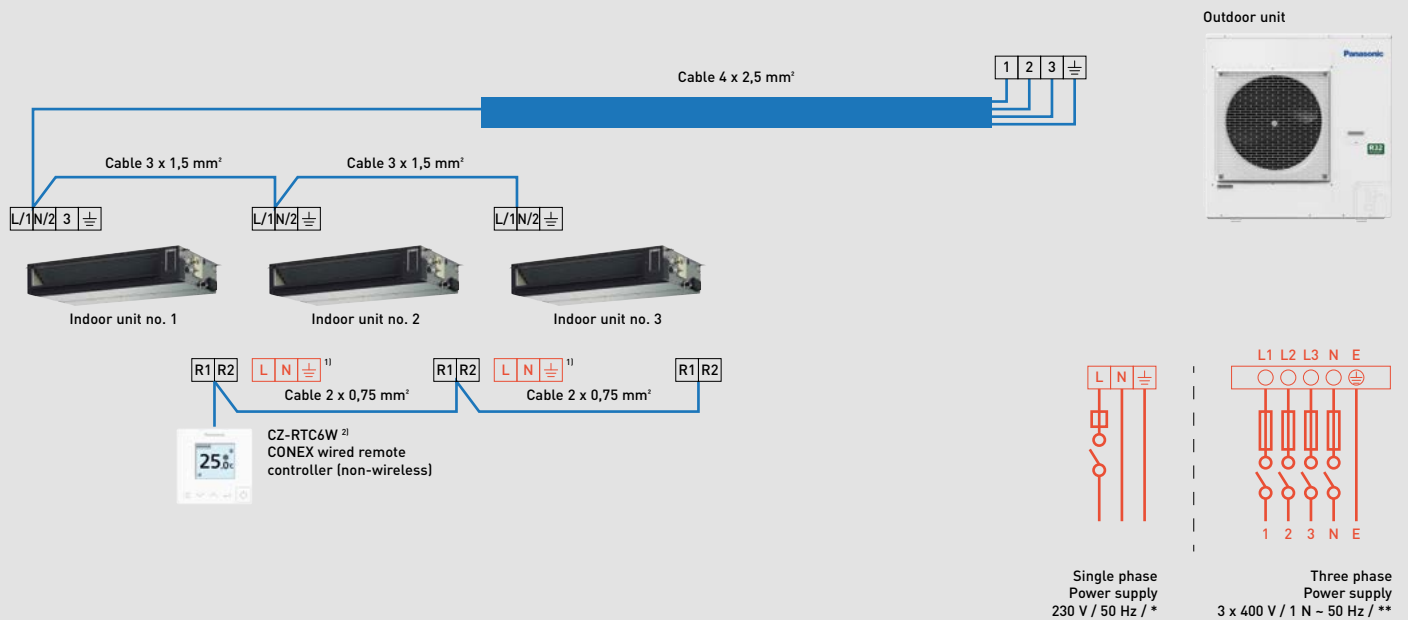

Single phase

Outdoor unit	Power supply	Circuit breaker*
U-71PZH4E5	220 / 230 / 240 V	25 A
U-100PZH4E5		35 A
U-125PZH4E5		40 A
U-140PZH4E5		40 A

1) Optional connection of single phase power supply connection to unit no. 2 and unit no. 3. Please refer to installation instructions for details. 2) Optional infrared remote controller is also possible. Wireless receivers may be required depending on indoor units.

Three phase

Outdoor unit	Power supply	Circuit breaker**
U-71PZH4E8	380 / 400 / 415 V	16 A
U-100PZH4E8		16 A
U-125PZH4E8		16 A
U-140PZH4E8		16 A
U-200PZH4E8		20 A
U-250PZH4E8		25 A

PACi NX double-twin system.

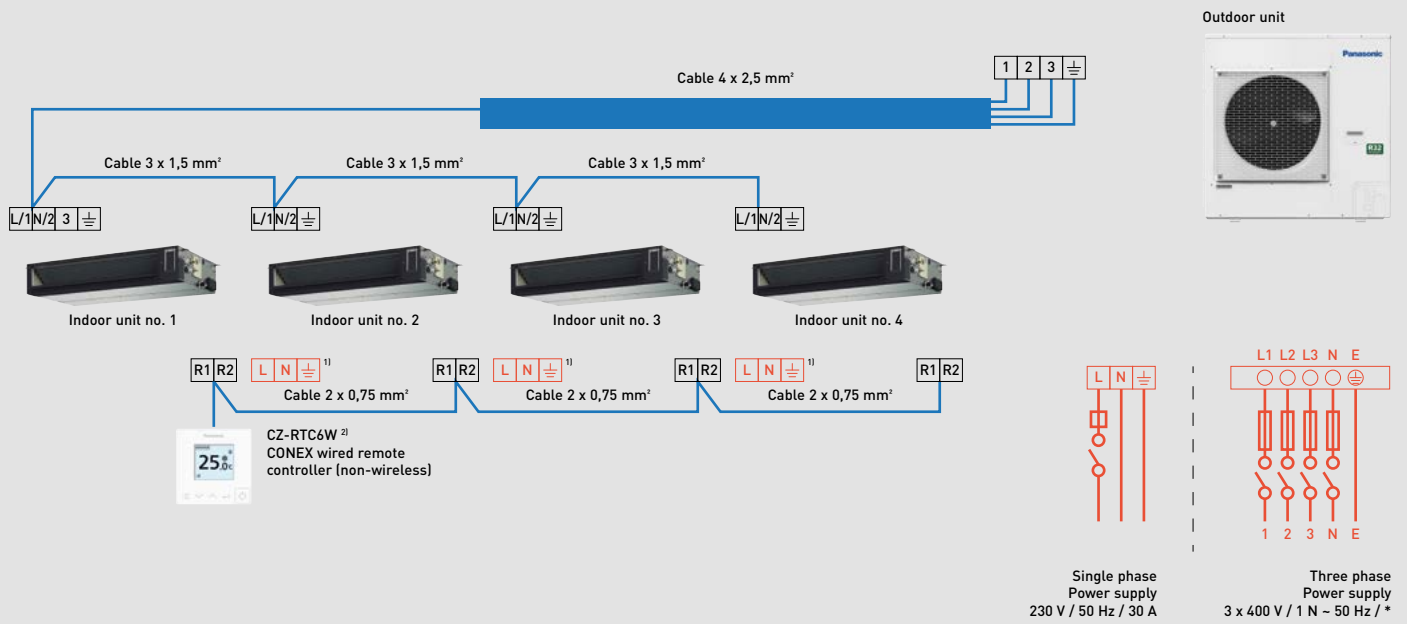

**Single phase**

Outdoor unit	Power supply	Circuit breaker
U-100PZH4E5	220 / 230 / 240 V	35 A
U-125PZH4E5		40 A

1) Optional connection of single phase power supply connection to unit no. 2, unit no. 3 and unit no. 4. Please refer to installation instructions for details. 2) Optional infrared remote controller is also possible. Wireless receivers may be required depending on indoor units.

**Three phase**

Outdoor unit	Power supply	Circuit breaker*
U-100PZH4E8	380 / 400 / 415 V	16 A
U-125PZH4E8		16 A
U-200PZH4E8		20 A
U-250PZH4E8		25 A

PACi twin system.

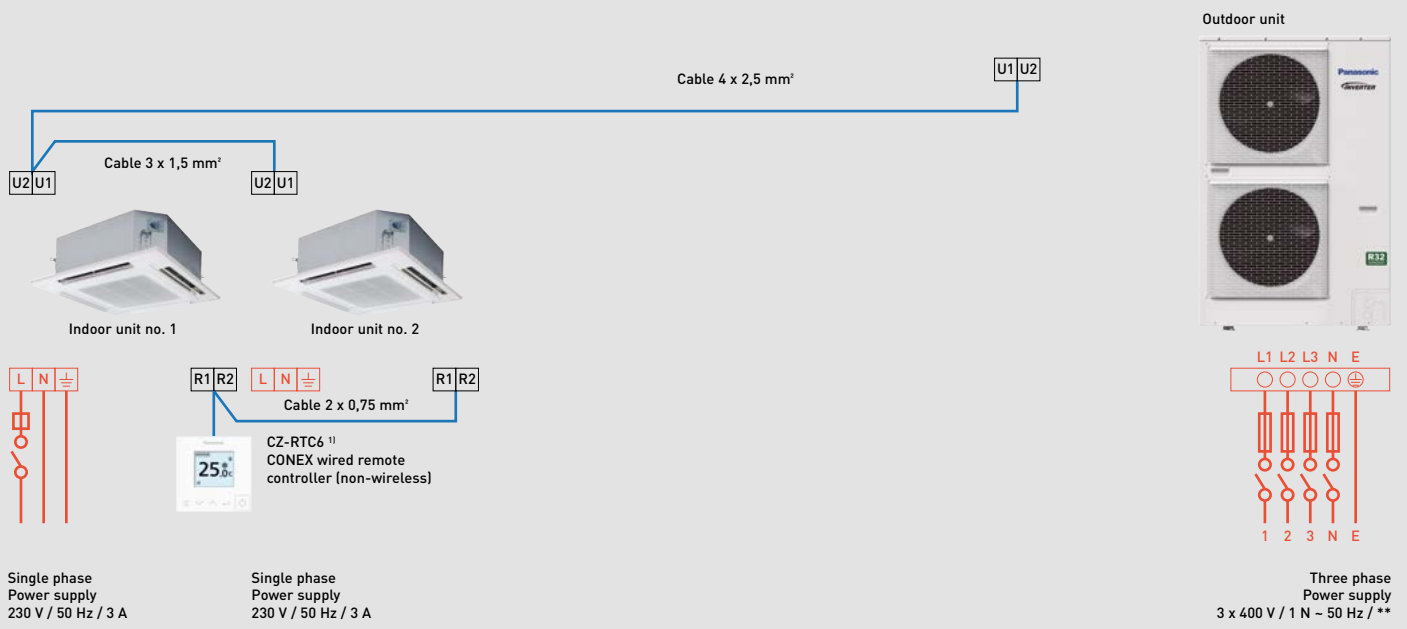

**Three phase**

Outdoor unit	Power supply	Circuit breaker
U-200PZH2E8	380 / 400 / 415 V	20 A
U-250PZH2E8	380 / 400 / 415 V	25 A

1) Optional infrared remote controller is also possible. Wireless receivers may be required depending on indoor units.

PACi triple system.

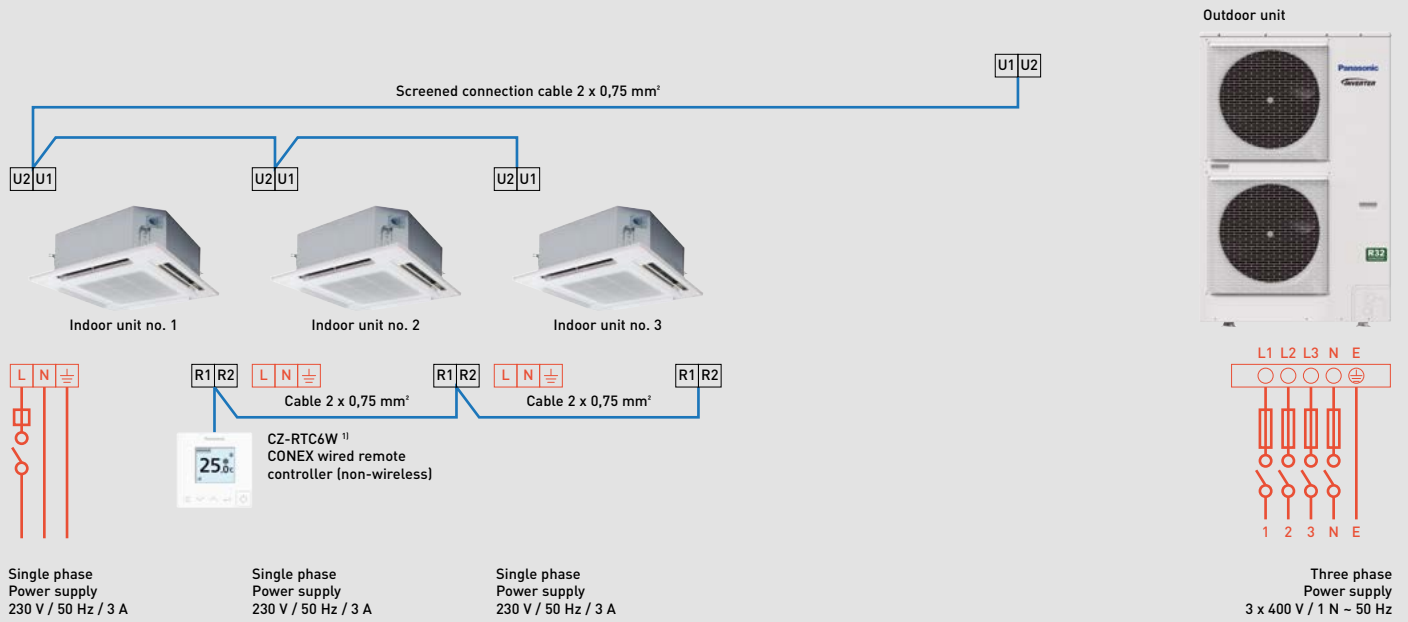

Three phase

Outdoor unit	Power supply	Circuit breaker
U-200PZH2E8	380 / 400 / 415 V	20 A

1) Optional infrared remote controller is also possible. Wireless receivers may be required depending on indoor units.

PACi double-twin system.

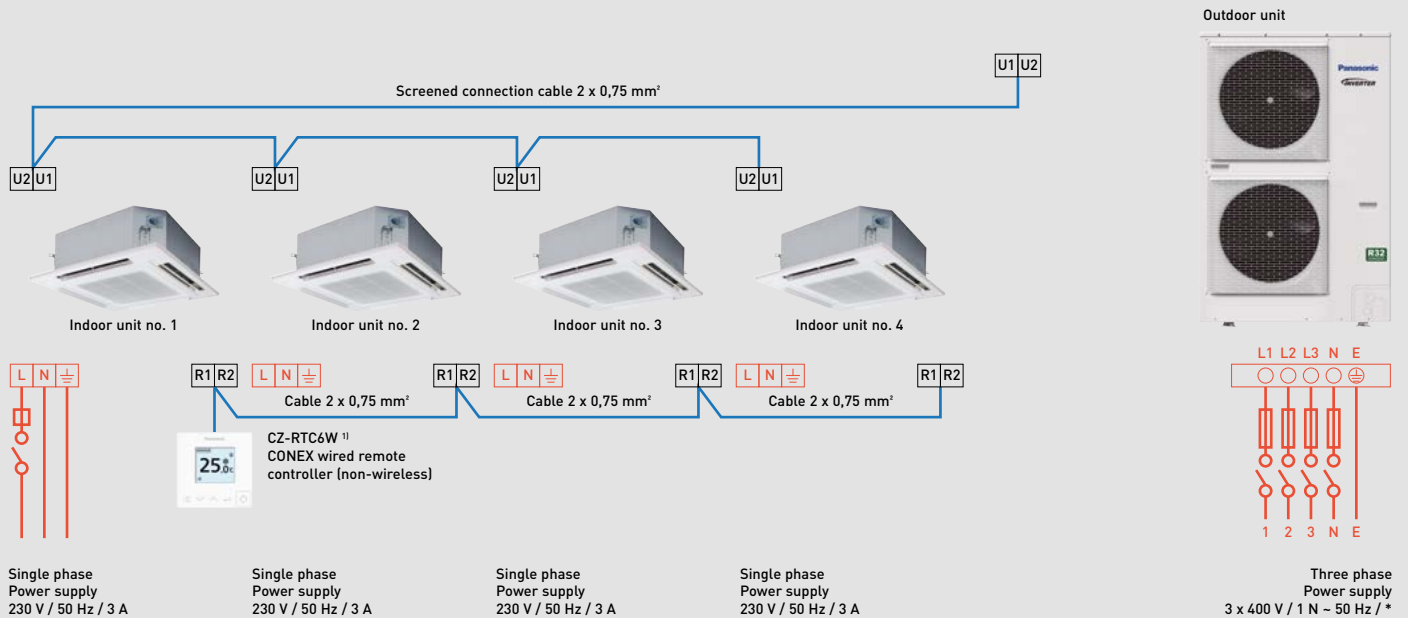

Three phase

Outdoor unit	Power supply	Circuit breaker
U-200PZH2E8	380 / 400 / 415 V	20 A
U-250PZH2E8	380 / 400 / 415 V	25 A

1) Optional infrared remote controller is also possible. Wireless receivers may be required depending on indoor units.

Mini ECOi Series.

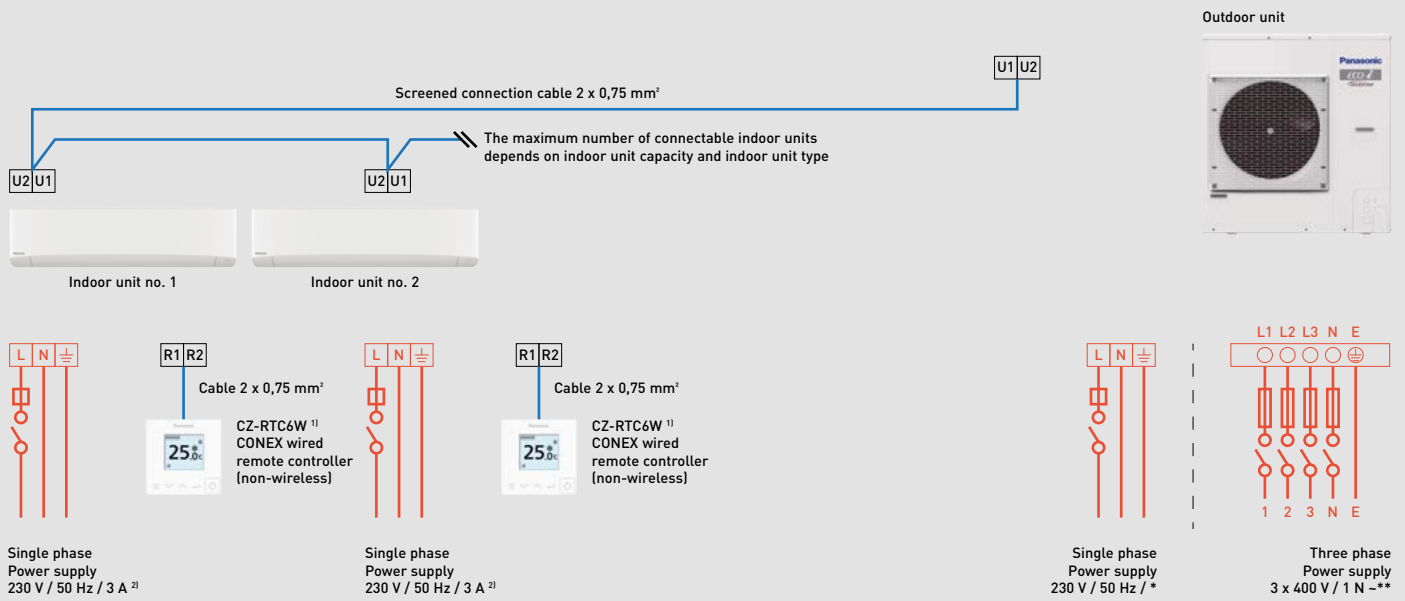

Single phase

Outdoor unit	Power supply	Circuit breaker*
U-4LZ2E5	220 / 230 / 240 V	20 A
U-5LZ2E5		25 A
U-6LZ2E5		30 A
U-4LE2E5		20 A
U-5LE2E5		25 A
U-6LE2E5		30 A

1) Optional infrared remote controller is also possible. Wireless receivers may be required depending on indoor units.  
2) 10 A for single indoor connection to S-224ME2E5 / S-280ME2E5, in combination with U-8LE1E8 / U-10LE1E8.

Three phase

Outdoor unit	Power supply	Circuit breaker**
U-4LZ2E8	380 / 400 / 415 V	10 A
U-5LZ2E8		16 A
U-6LZ2E8		16 A
U-8LZ2E8		16 A
U-10LZ2E8		20 A
U-4LE2E8		10 A
U-5LE2E8		16 A
U-6LE2E8		16 A
U-8LE1E8		16 A
U-10LE1E8		20 A

ECOi EX and ECO G Series.

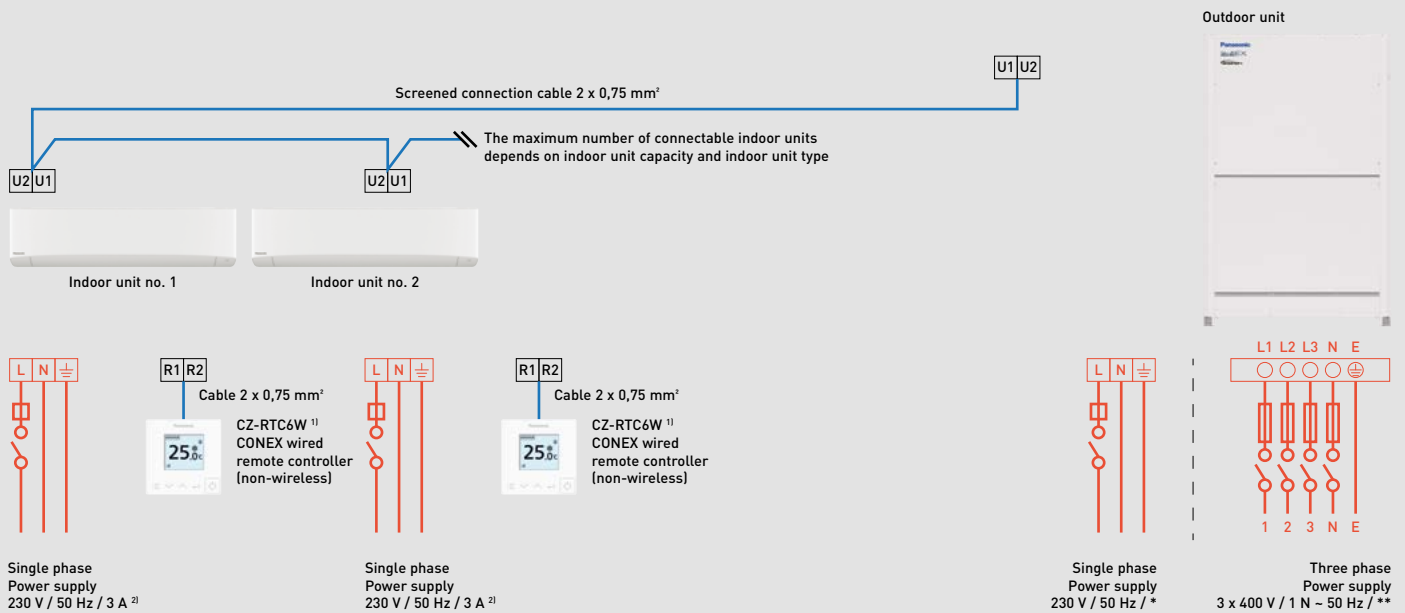

ECOi EX Series

2-Pipe			3-Pipe		
Outdoor unit	Power supply	Circuit breaker**	Outdoor unit	Power supply	Circuit breaker**
U-8ME2E8	380 / 400 / 415 V	16 A	U-8MF3E8	380 / 400 / 415 V	16 A
U-10ME2E8		16 A	U-10MF3E8		20 A
U-12ME2E8		20 A	U-12MF3E8		25 A
U-14ME2E8		25 A	U-14MF3E8		40 A
U-16ME2E8		30 A	U-16MF3E8		30 A
U-18ME2E8		40 A			
U-20ME2E8		40 A			

ECO G Series

2-Pipe			3-Pipe		
Outdoor unit	Power supply	Circuit breaker*	Outdoor unit	Power supply	Circuit breaker*
U-16GE3E5	220 / 230 / 240 V	16 A	U-16GF3E5	220 / 230 / 240 V	16 A
U-20GE3E5		16 A	U-20GF3E5		16 A
U-25GE3E5		16 A	U-25GF3E5		16 A
U-30GE3E5		16 A			

1) Optional infrared remote controller is also possible. Wireless receivers may be required depending on indoor units.  
2) 10 A for single indoor connection to S-224ME2E5 / S-280ME2E5.

Hybrid GHP/EHP.

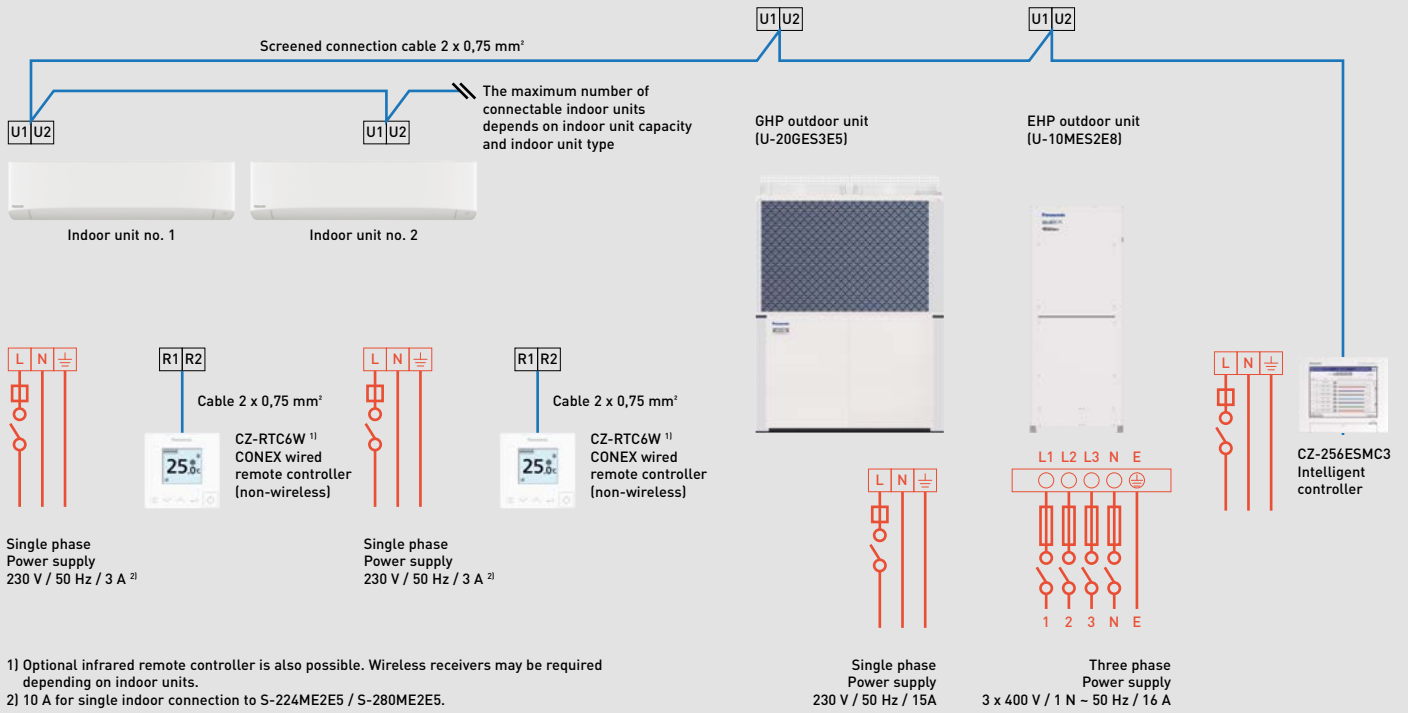

1) Optional infrared remote controller is also possible. Wireless receivers may be required depending on indoor units.  
 2) 10 A for single indoor connection to S-224ME2E5 / S-280ME2E5.

# Panasonic Heating & Cooling Solutions customer service

Panasonic enables different channels for end users or professionals to get in touch with us:



Use our European website **www.aircon.panasonic.eu** for contacting us.

Panasonic has implemented a contact page on the Panasonic Heating & Cooling Solutions website for potential or existing Panasonic customers.



Another option is to contact the highly experienced teams at the Panasonic customer service center, who are more than qualified to support Panasonic clients in 13 different languages across Europe.

## Our service center in Europe for end customers:

Country	B2C support center	Opening times
Belgium NL	+32 2 320 55 38	Mo-Fr 9-17h
Belgium FR	+32 2 320 55 38	Mo-Fr 9-17h
Luxemburg	+32 2 320 55 38	Mo-Fr 9-17h



Do not add or replace refrigerant other than the specified type. Manufacturer is not responsible for the damage and deterioration in safety due to usage of the other refrigerant.  
The outdoor units in this catalogue contains fluorinated greenhouse gases with a GWP higher than 150.

# Panasonic®

To find out how Panasonic cares for you,  
log on to: [www.aircon.panasonic.eu](http://www.aircon.panasonic.eu)

Panasonic Marketing Europe GmbH  
Panasonic Heating & Ventilation Air-conditioning BeNeLux  
Dok-Noord 3A, 9000 Gent, Belgium  
Europalaan 28E, 5232 BC 's-Hertogenbosch, Nederland  
[www.aircon.panasonic.eu](http://www.aircon.panasonic.eu)