

Panasonic

ECO*i* EX

ECO*i*





# Commercial VRF – ECOi

Panasonic VRF Systems are specifically designed for energy saving, easy installation and high-efficiency performance, providing a comfort and better Indoor Air Quality (IAQ) solution. A wide range of outdoor and indoor unit models offer unique features which are designed for the most demanding offices and large buildings.

## ABOUT

VRF highlighted features	→ 4
Panasonic VRF: TOP in comfort	→ 6
Bringing nature's balance indoors	→ 8
BION air pollutant filter (optional)	→ 10
Solutions for Restaurants	→ 12
Your entire hotel with superior comfort	→ 14
Innovative solutions for retail	→ 16
<hr/>	
Mini ECOi LZ2 Series R32	→ 20
Mini ECOi LE Series R410A	→ 24
ECOi EX range	→ 28
2-Pipe ECOi EX MZ1 Series R32	→ 34
3-Pipe ECOi EX MF4 Series R32	→ 38
2-Pipe ECOi EX ME2 Series R410A	→ 42
3-Pipe ECOi EX MF3 Series R410A	→ 50
Slim 3-Pipe control box kit / Multiple connection type	→ 51
<hr/>	
Water heat exchanger for hydronic applications	→ 76
<hr/>	
Leak detection and automatic refrigerant Pump Down for R410A refrigerant	→ 56
<hr/>	
Panasonic DX PRO Designer	→ 58
<hr/>	
R22 Renewal	→ 59
<hr/>	
Features explained	→ 102
<hr/>	
VRF outdoor units range	→ 18
VRF indoor units range	→ 60
<hr/>	
ECOi compatible models	→ 86

## PRODUCT SPECIFICATIONS

### VRF outdoor units range

Mini ECOi LZ2 Series 4 to 6 HP · R32	→ 22
Mini ECOi LZ2 Series 8 and 10 HP · R32	→ 23
Mini ECOi LE2 Series high-efficiency 4 to 6 HP · R410A	→ 26
Mini ECOi LE1 Series high-efficiency 8 and 10 HP · R410A	→ 27
2-Pipe ECOi EX MZ1 Series · R32	→ 35
3-Pipe ECOi EX MF4 Series · R32	→ 39
2-Pipe ECOi EX ME2 Series · R410A	→ 45
3-Pipe ECOi EX MF3 Series · R410A	→ 54

### VRF indoor units range

U2 type 4 way 90x90 cassette · R32 / R410A	→ 63
Y3 type 4 way 60x60 cassette · R32 / R410A	→ 64
L1 type 2 way cassette · R410A	→ 65
D1 type 1 way cassette · R410A	→ 66
F3 type variable static pressure adaptive duct · R32 / R410A	→ 67
M2 type slim variable static pressure hide-away concealed duct · R32 / R410A	→ 68
E2 type high static pressure hide-away · R410A	→ 69
K3 type wall-mounted · R32 / R410A	→ 71
T2 type ceiling · R410A	→ 72
G1 type floor console · R410A	→ 73
P2 type floor-standing · R32 / R410A	→ 74
R2 type concealed floor-standing · R32 / R410A	→ 74
Hydrokit for ECOi, water at 45 °C · R410A	→ 75
2-Pipe ECOi EX ME2 Series with water heat exchanger	→ 77

### Ventilation

AHU connection kit MAH4M for ECOi 2-Pipe	→ 78
Advanced energy recovery ventilation - ZY Series	→ 82
Energy recovery ventilation with DX coil -HRPT Series	→ 83
Air curtain with DX coil, connected to ECOi 2-Pipe	→ 84
Ceiling mounted air-e nanoe X Generator	→ 85
<hr/>	
Accessories and control	→ 87
<hr/>	
Dimension and tube sizes of branches and headers	→ 94
<hr/>	
Eurovent certified technical data	→ 98

# VRF highlighted features

Panasonic provides an extensive range of solutions for medium and large sized buildings, combining the best options to satisfy all needs and site restrictions.



		Capacity range	Extreme temperatures operation	Maximum number of connectable indoor units	Indoor to outdoor connection ratio	Indoor units	Controls	Other ranges integration
R32	<b>Mini ECOi LZ2</b> 	4 - 10 HP	-20 °C in heating mode 52 °C in cooling mode	16 <sup>1)</sup>	50 ~ 150%			PACi NX range full control integration + Domestic range integration by accessory
	<b>ECOi EX MZ1</b> 	8 - 48 HP	-25 °C in heating mode 52 °C in cooling mode	43	50 ~ 130%	All (check restrictions)	All	
	<b>ECOi MF4</b> 	8 - 36 HP	-20 °C in heating mode 52 °C in cooling mode	52	50 ~ 150%			
R410A	<b>Mini ECOi LE2/LE1</b> 	4 - 10 HP	-20 °C in heating mode 46 °C in cooling mode	15	50 ~ 130%			PACi NX range full control integration + Domestic range integration by accessory
	<b>ECOi EX ME2</b> 	8 - 80 HP	-25 °C in heating mode 52 °C in cooling mode	64	50 ~ 200%	All (check restrictions)	All	
	<b>ECOi EX MF3</b> 	8 - 48 HP	-20 °C in heating mode 52 °C in cooling mode	52	50 ~ 150%			

1) For 6 HP model. 2) 50 ~ 200% only when one outdoor unit is installed. In other cases 50 ~ 130%.

## The complete VRF solution for efficiency, quality, and comfort

To meet the latest market demands for decarbonised buildings, the ECOi range with R32 refrigerant has been expanded to 48 HP offering a comprehensive portfolio. In line with F-gas regulations, R32 ECOi is a future-ready VRF solution.



### Panasonic VRF, extended decarbonised solution.

R32 ECOi range from 4–12 HP, expandable up to 48 HP. A comprehensive line-up featuring nanoe™ X indoor units, hydronic and ventilation solutions, and seamless BMS connectivity.

R32  
GWP REDUCED BY  
**68%**<sup>1)</sup>



**CO<sub>2</sub> SUSTAINABLE YET HIGHLY EFFICIENT**

Cut GWP by 68%<sup>1)</sup> and total CO<sub>2</sub>-eq by up to 82%<sup>2)</sup> through lower refrigerant volume and improved efficiency.

**R32 RELIABILITY - R32 STANDARD-COMPLIANT**

Panasonic provides safety measures that meet the latest standards and R32 density requirements for each project.

**-25 °C DESIGN FLEXIBILITY**

- Up to 1000 m piping
- Heating to -25 °C
- Wide indoor unit range with nanoe™ X
- Flexible connectivity: standalone, central and BMS integration

1) GWP of R32 refrigerant is 675, while the GWP of R410A is 2088. 2) Total CO<sub>2</sub> Eq= GWP x charge. Panasonic's internal research conducted under consistent system conditions.

## Complete ECOi solution.

**Bringing nature's balance indoors.**  
Wide range of air to air indoor line-up with nanoe™ X.



**Improve Indoor Air Quality.**  
A range of ventilations including ERVs and AHU connection kits.



**Hydronic modules.**  
To provide heating and hot water.



**Seamless connectivity integration.**  
Single to centralized control, multi-site control solutions and BMS integrations.



**One platform for total control across all your sites, 24/7 and remotely.**  
Commercial Smart Edge.



**Other ranges integration.**  
PACi NX range: full control integration + domestic range integration via accessory.

## Panasonic VRF: TOP in comfort

Since 2006, all Panasonic VRF systems have included special VET technology, with variable refrigerant temperature control, as standard.



### Variable Evaporation and Condensation Temperature.

Our 'smart logic' system checks the temperature every 30 seconds, automatically adjusting the refrigerant temperature according to actual demand and outdoor conditions. This ensures better energy performance at all times.

### Temperature varies from 16 °C to 3 °C.

Similarly, the condensation temperature is also variable and is adjusted to the room thermal load, within a range of 33 - 55 °C.

Refrigerant evaporation temperature (°C).

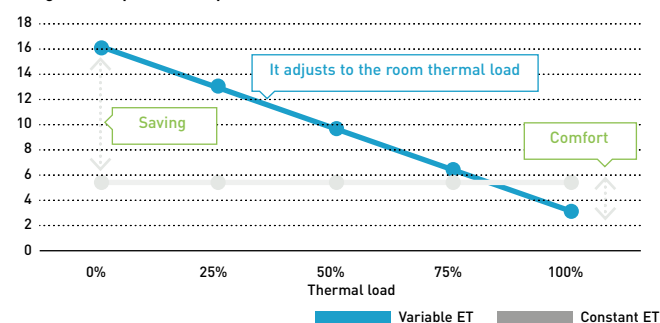

Refrigerant condensation temperature (°C).

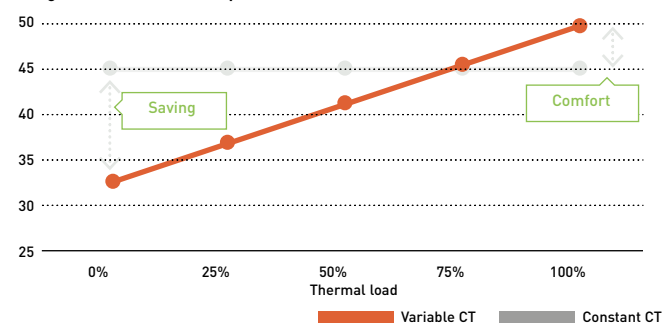

### Example of cooling mode (similarly applicable to heating mode).

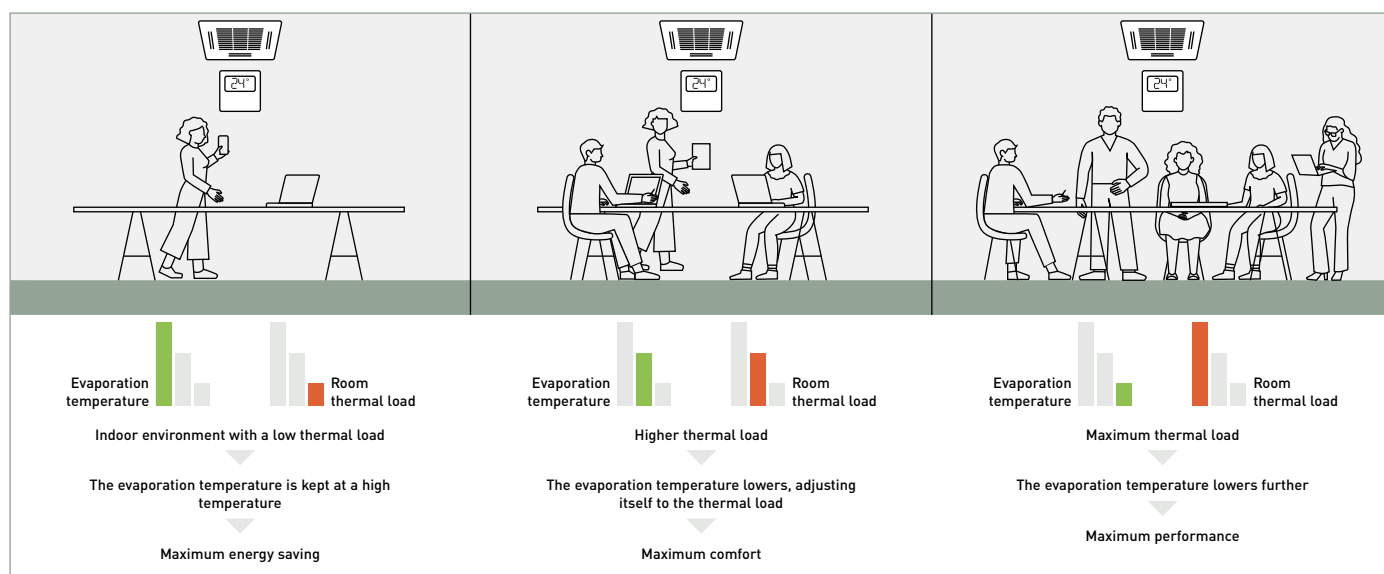

### Technical focus on variable temperatures

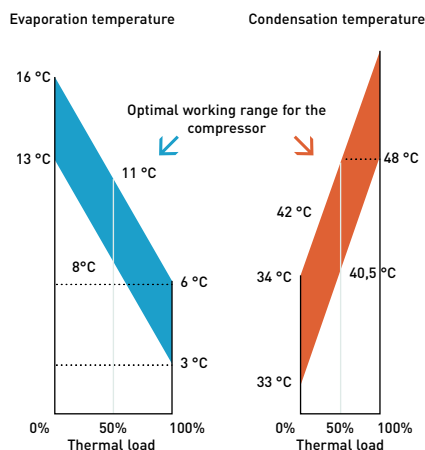

### Control of the discharge temperature

This special function is available in all of Panasonic VRF systems' indoor units to guarantee maximum comfort for the end user. For example, in cooling mode, if the temperature of the discharged air was below 10 °C, the user may feel discomfort, just as he would do in heating mode if the temperature was far too high. With the Panasonic control of the discharge air temperature, this can be adjusted within a cooling range of 7 - 22 °C.

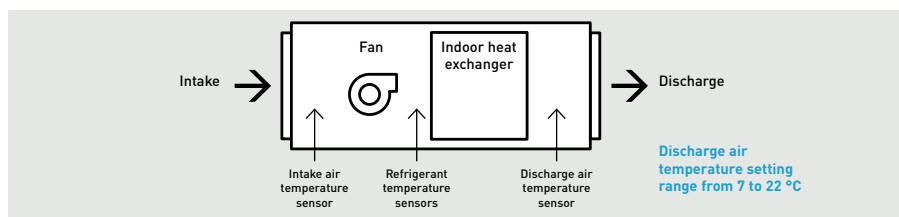

### Benefits:

- The air will never be too cold or too warm
- Available in cooling and in heating
- Higher comfort
- Energy saving
- It prevents the formation of condensation within ducts and vents, improving levels of hygiene

# Bringing nature's balance indoors



nanoe™ X, technology with the benefits of hydroxyl radicals.

Abundant in nature, hydroxyl radicals (also known as OH radicals) have the capacity to inhibit pollutants, viruses, and bacteria to clean and deodorise. nanoe™ X technology can bring these incredible benefits indoors so that hard surfaces, soft furnishings, and the indoor environment can be a cleaner and more pleasant place to be, whether at home, work, or visiting hotels, shops and restaurants etc.



## What is unique about nanoe™ X?

**Effective on fabrics and surfaces.**

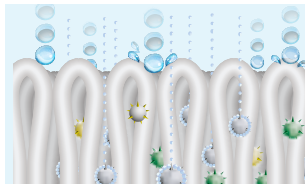

1 | At one billionth of a metre, nanoe™ X is much smaller than steam and can deeply penetrate cloth fabrics to deodorise.

**Longer lifespan.**



2 | Contained in tiny water particles, nanoe™ X has a long lifespan, which is about 600 seconds, to spread easily around the room.

**Huge quantity.**



3 | nanoe X Generator Mark 3 produces 48 trillion hydroxyl radicals per second. Greater amounts of hydroxyl radicals contained in nanoe™ X lead to higher performance on inhibition of pollutants.

**Maintenance-free.**

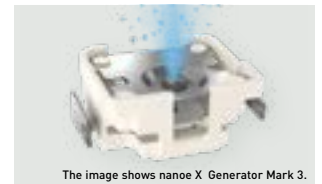

4 | No service and maintenance required. nanoe™ X is a filter free solution that does not require maintenance, as its atomisation electrode is enveloped with water during its generation process and it is made with Titanium.

## 7 effects of nanoe™ X – Panasonic unique technology

**Deodorises**



Odours

**Capacity to inhibit 5 types of pollutants**

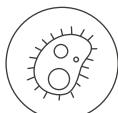

Bacteria and viruses

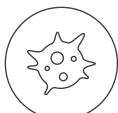

Mould



Allergens



Pollen



Hazardous substances



Skin and hair

\*Refer to <https://aircon.panasonic.eu> for more details and validation data.

## First nanoe™ device was developed by Panasonic in 2003

**Generator: nanoe™**

2003

480 billion hydroxyl radicals/sec

**Ion particle structure**

Hydroxyl radicals

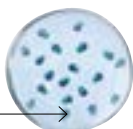

**Generator: nanoe™ X**

**Mark 1 - 2016**

4,8 trillion hydroxyl radicals/sec

**10x times**

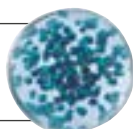

**Mark 2 - 2019**

9,6 trillion hydroxyl radicals/sec

**20x times**

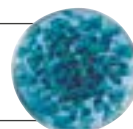

**Mark 3 - 2022**

48 trillion hydroxyl radicals/sec

**100x times**

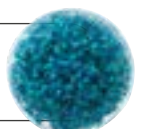

## nanoe™ X has evolved again - the nanoe X Generator Mark 3.

The latest of the continuously evolving nanoe™ X technology, it has the largest amount of hydroxyl radical in the history of nanoe™ which generates 48 trillion hydroxyl radical per second, 100 times the hydroxyl radical contained in traditional nanoe™. The increased number of hydroxyl radical, which are the key to nanoe™ cleaning power, means you can expect an even higher level of performance.



nanoe™ X is an internationally-validated technology. Official test reports are available.

### Meets the requirements of VDI 6022 and HACCP

Certified under VDI 6022, meeting one of the strictest hygiene requirements on the market for HVAC systems, and aligned with HACCP-based food-safety practices.



**VDI 6022 – Part 5 <sup>1)</sup> Certification.**

**Avoidance of allergenic exposure.**  
Inhibits a wide range of harmful bacteria, viruses, mould, pollen and allergens.



**VDI 6022 – Part 1 <sup>1)</sup> & 1.1 <sup>2)</sup> Certification.**

**Ventilation and indoor-air quality.**  
Panasonic nanoe™ X technology improving indoor air quality.



**HACCP Food Safety Certified <sup>3)</sup> – Europe's first HVAC manufacturer.**

1) Certification mark only valid for nanoe X Generator Mark 3. 2) Certification mark only valid for nanoe X Generator Mark 2 and Mark 3. 3) Applicable to PACi NX and ECOi indoor units equipped with nanoe X Generator Mark 3.

### Higher concentration, even in large spaces

Greater effectiveness even in large spaces of more than 100 m<sup>2</sup>.

Conditions of the simulation: Inspection / model: 4 way cassette / room size: 112 m<sup>2</sup> / room height: 2,4 m / position of IDU: centre of space / ventilation: 3 times/hour.

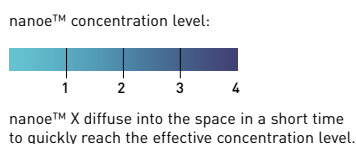

Simulation with nanoe X Generator Mark 3 in a room size of 112 m<sup>2</sup>

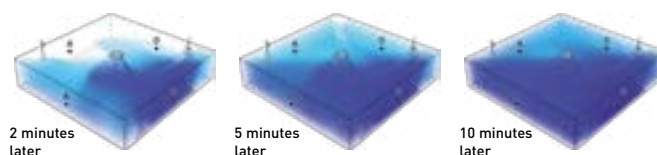

### Effectiveness in large space with Generator Mark 3

**Inhibits virus:** An air conditioner equipped with nanoe X Generator Mark 3 inhibits activity of adhered virus (Bacteriophage) by 98,81% in 4 hours <sup>1)</sup>.

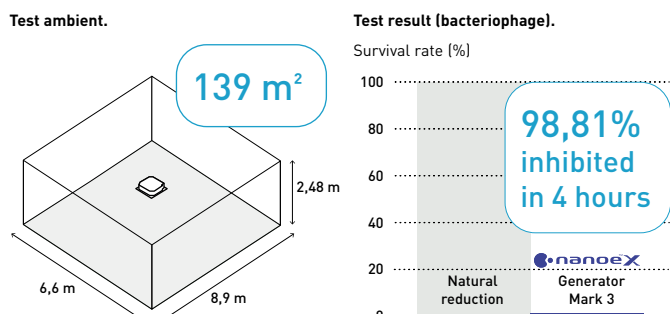

**Inhibits pollen:** The result of nanoe X Generator Mark 3. Inhibits pollen in 1/4 the time of nanoe X Generator Mark 2 <sup>2)</sup>.

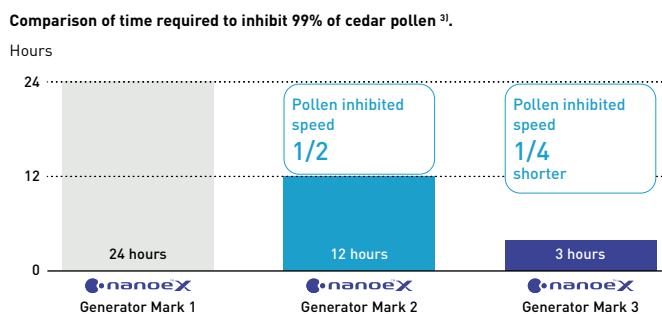

<sup>1)</sup> Testing organisation: SGS Inc / Test subject: Adhered Bacteriophage / Test volume: Approx. 139 m<sup>2</sup> large space (6,6 x 8,9 x 2,48 m). Test result: Inhibited 98,81% in 4 hours. Test report no.: SHES210901902593. <sup>2)</sup> Effect after 3 hours in a test space of approx. 24 m<sup>2</sup>. The figures are not the results of testing in an actual operating space. <sup>3)</sup> nanoe X Generator Mark 1: [Testing organisation] Panasonic Product Analysis Center [Test method] ELISA method of measuring allergens adhering to fabric in a test room (approx. 24 m<sup>2</sup>) [Method of inhibition] Release of nanoe™ [Target] Adhered allergen (cedar pollen) [Test Result] Inhibition of 99% or more in 24 hours (4AA33-151001-F01). nanoe X Generator Mark 2: [Testing organisation] Panasonic Product Analysis Center, [Test method] ELISA method of measuring allergens adhering to fabric in a test room (approx. 24 m<sup>2</sup>) [Method of inhibition] Release of nanoe™ [Target] Adhered allergen (cedar pollen) [Test Result] Inhibition of 99% or more in 12 hours confirmed (L19YA009). nanoe X Generator Mark 3: [Testing organisation] Panasonic Product Analysis Center [Test method] ELISA method of measuring allergens adhering to fabric in a test room (approx. 24 m<sup>2</sup>) [Method of inhibition] Release of nanoe™ [Target] Adhered allergen (cedar pollen) [Test Result] Inhibition of 99% or more in 3 hours (H21YA017-1).

### Panasonic Heating & Cooling Solutions is incorporating nanoe™ technology in a wide range of equipment

- 

**U2 type 4 way 90x90 cassette.**  
Built-in nanoe X Generator Mark 3.
- 

**G1 type floor console.**  
Built-in nanoe X Generator Mark 1.
- 

**Y3 type 4 way 60x60 cassette.**  
Built-in nanoe X Generator Mark 3.
- 

**P2 type floor-standing.**  
Built-in nanoe X Generator Mark 3.
- 

**K3 type wall-mounted.**  
Built-in nanoe X Generator Mark 3.
- 

**R2 type concealed floor-standing**  
Built-in nanoe X Generator Mark 3.
- 

**F3 type adaptive duct.**  
Built-in nanoe X Generator Mark 3.
- 

**Ceiling mounted air-e nanoe X Generator.**  
Built-in nanoe X Generator Mark 1.
- 

**M2 type hide-away.**  
Built-in nanoe X Generator Mark 3.

## BION air pollutant filter (optional)

Collaborating with BION, experts in filtration equipment, a new molecular filtration is available to improve indoor air quality.





The efficiency of nitrogen dioxide (NO<sub>2</sub>) removal can reach **99,5%\***

\*Measured by ASTM6646 international standards. Efficiency reaches 99,5% within 4,8 seconds of contact time with the media bed (FAM filter). \*\*The performance varies depending on the room size, environment and usage and it may take several hours to reach the full effect. BION air pollutant filter is not medical device, local regulations on building design must be followed. Test results conducted under controlled laboratory conditions. Performance of BION air pollutant filter might differ in real life environment.

**BION air pollutant filter traps and reduces certain types of harmful pollutant gases, listed below**

- Nitrogen oxides (NO<sub>x</sub>)
- Ozone (O<sub>3</sub>)
- Sulfur dioxide (SO<sub>2</sub>)
- Formaldehyde (HCHO)
- Volatile organic compounds (VOCs)

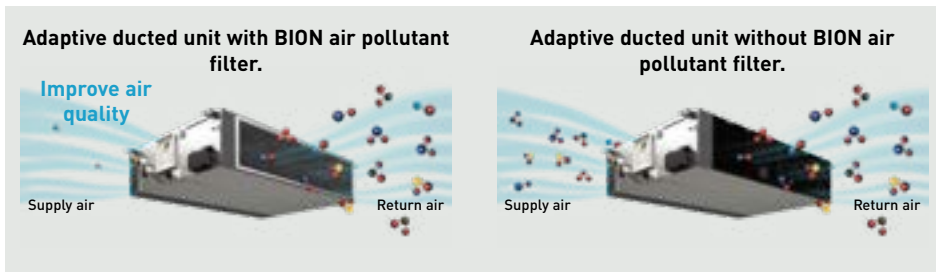

**The BION air pollutant filter is an ideal solution for improving indoor air quality in urban areas.**

**Air pollution in urban areas in Europe**

It is reported that in 2021, a significant portion of the Europe's urban population has been exposed to high levels of key air pollutants\*.

- 75% of the urban population was exposed to NO<sub>2</sub> concentrations above 10 µg/m<sup>3</sup>
- 94% were exposed to concentrations of O<sub>3</sub> above 60 µg/m<sup>3</sup>

\*The "Europe's Air Quality Status 2023" report (EEA, 2023) assesses levels of air pollutants measured in ambient air across Europe (> 2000 locations) for the years 2021 and 2022. It compares them against both EU standards as set out in the Ambient Air Quality Directives and the 2021 WHO Air Quality Guidelines.

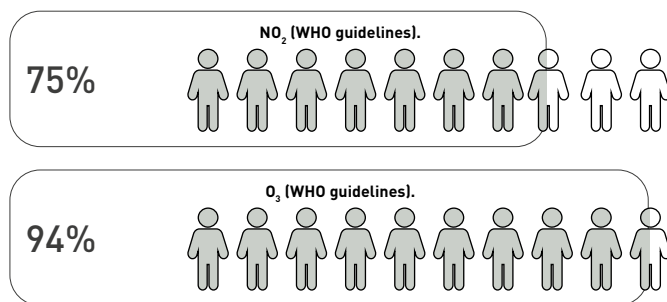

Share of the Europe's urban population exposed to air pollutant concentrations above EU standards and WHO guidelines in 2021, as referenced in the EEA 2023.

**Why outdoor air pollution matters to IAQ?**

Poor indoor air quality is associated with outdoor air pollutants such as car exhaust and factory fumes, and the two are closely linked. A significant portion of human exposure to air pollution occurs when they are indoors.



**Different objectives, different IAQ solutions**

In today's world, we are concerned about wellbeing and the air we breathe. And technology exists to ensure improved indoor air quality. With the introduction of the BION air pollutant filter, Panasonic offers IAQ solutions optimized for various target objectives.

IAQ Solution	nanoe™ X	BION air pollutant filter
<b>Objectives</b>	Inhibit particles such as pollutants, certain types of viruses, and bacteria to clean and deodorise	Inhibit gases such as nitrogen oxides (NO <sub>x</sub> ), ozone (O <sub>3</sub> ), sulfur dioxide (SO <sub>2</sub> ), formaldehyde (HCHO) and volatile organic compounds (VOCs)
<b>Technology</b>	Hydroxyl radicals contained in water	Molecular filtration
<b>Filtering mechanism</b>	Physical capture of particles	Adsorption and absorption
<b>Availability</b>	Built into all air-to-air indoor units as a standard	Optional accessory for the adaptive ducted unit (PF3/MF3)

<b>BION air pollutant filter*</b>	PAW-APF800F	PAW-APF1000F	PAW-APF1400F
<b>Compatible adaptive ducted unit</b>	MF3 15, 22, 28, 36, 45 and 56	MF3 60 and 73	MF3 90, 112, 140 and 160

\*The filter cartridge and filter casing are included in the package.

# Solutions for Restaurants

## Full heating, cooling and DHW solutions for Restaurants.



### 1 Electric VRF. ECOi EX and Mini ECOi.

ECOi electrical VRF is specifically designed for the most demanding restaurants. High-efficiency system. Extended operating range to provide heating at outdoor temperature as low as -25 °C (2-Pipe ECOi EX). Suitable for refurbishment projects.

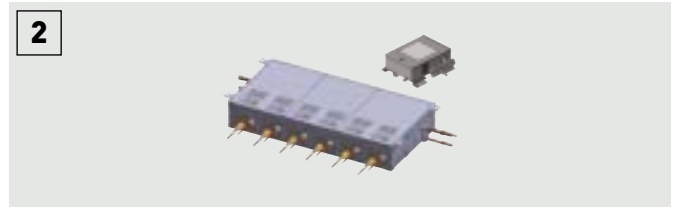

### 2 3-Pipe control box kit.

Heat Recovery box to connect multiple indoor units with just one box, 4, 6 and up to 8 indoor units or groups. This is good advantage in the restaurants, where space for connecting several boxes is limited.



### 3 Aquarea T-CAP.

Ideal for heating, cooling and for production of big quantities of hot water at 75 °C, Aquarea have a extremely quick return on investment and a low CO<sub>2</sub> footprint.



### 4 Water heat exchanger for ECOi.

Efficient hot water production supported by a high-performance class A water pump.



### 5 AHU connection kit for efficient ventilation.

The AHU connection kit is specially designed to improve the efficiency of the pre-heating or pre-cooling ventilation process.

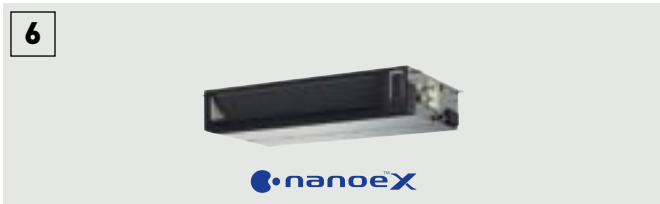

### 6 Adaptive ducted with nanoe™ X.

Super silent units deliver the ideal air supply. Units available from 1,5 kW providing precise temperature control even in small rooms. 2 installation possibilities (horizontal / vertical) with high ESP 150 Pa allows for flexible installation. nanoe™ X is built-in as standard.



### 7 Mini Cassette.

The Y3 type 4 way 60x60 cassette unit has modern and stylish panel design which matches with any type of the building design.



### 8 Control your way.

Wide variety of controls, from simple user control to full system control via remote access functionality. Touch panel and consumption control.



### 9 Air curtain with DX coil.

Designed for smooth operation and efficient performance.



### 10 Protocol friendly.

Great flexibility for integration into your KNX / Modbus / LonWorks / BACnet projects allows fully bi-directional monitoring and control of all the functioning parameters. Range of solutions to control locally or remotely the full system in bi-directional mode.



### 11 Commercial Smart Edge.

Manage the entire Panasonic HVAC portfolio across multi-site installations from a single platform, remotely, 24/7.



### 12 Condensing unit with natural refrigerant.

Panasonic CO<sub>2</sub> unit is the natural choice for showcases and cold rooms in restaurants. Always fresh foods from a future-proof refrigeration technology, without any contamination risk.

### Highly efficient at part load conditions.

Panasonic has solutions for optimising the installation of cooling, heating and DHW production in restaurants. While the kitchen needs cooling, heating is needed for DHW and also for heating the public area, with the advantage of 100% fresh air that removes odours. Combining all these needs smartly with Panasonic technology results in a simple and flexible system adaptable to any restaurant requests, with lower utility bills.

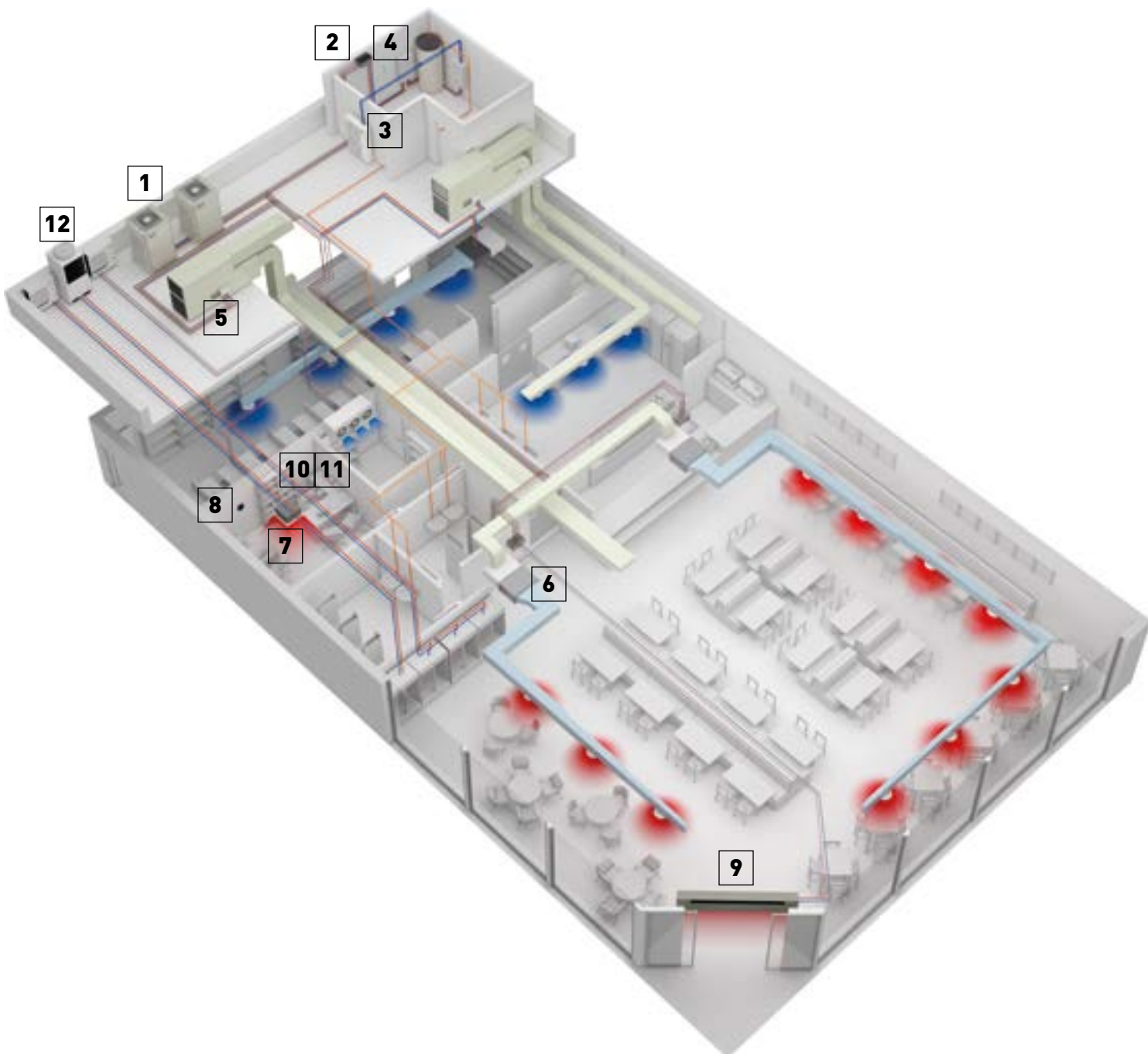

# Your entire hotel with superior comfort, control and savings too



**1 Electric VRF. ECOi EX.**  
 ECOi electrical VRF is specifically designed for the most demanding hotels. High-efficiency system. Extended operating range to provide heating at outdoor temperature as low as -25 °C (2-Pipe ECOi EX). Suitable for refurbishment projects.



**2 Hydronic units.**  
 Providing efficient hot and cold water.

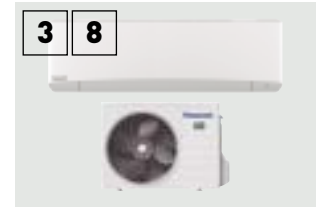

**3 8 YKEA unit for server room.**  
 Steady cooling, nonstop, even at -25 °C and still with high-efficiency. Ready for continuous operation and easy to connect 2 systems to automatically alternate and ensure server rooms are kept cool.



**4 AHU connection kit for efficient ventilation.**  
 The AHU connection kit is specially designed to improve the efficiency of the pre-heating or pre-cooling ventilation process.

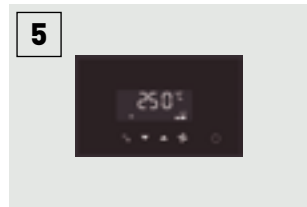

**5 Control your way.**  
 Wide variety of controls, from simple user control to full system control via remote access functionality. Touch panel, web server, consumption control, smartphone control... everything is possible.



**6 Wide range of indoor units.**  
 All units provided with supply air temperature sensor and low operation sound level to guarantee maximum guest comfort. Units equipped with nanoe™ X (available in specific models) provide better air quality in public spaces in the hotel.

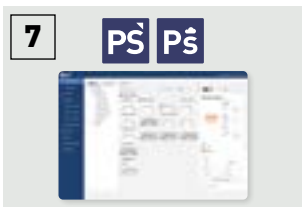

**7 Commercial Smart Edge.**  
 Manage the entire Panasonic HVAC portfolio across multi-site installations from a single platform, remotely, 24/7.



**8 Protocol friendly.**  
 Great flexibility for integration into your KNX / Modbus / LonWorks / BACnet projects allows fully bi-directional monitoring and control of all the functioning parameters.



**9 Air curtain with DX coil.**  
 Designed for smooth operation and efficient performance.



**10a Condensing unit with natural refrigerant.**  
 Panasonic CO<sub>2</sub> unit is the natural choice for an energy saving and climate-friendly solution.



**10b PACi NX Elite Series for cooling rooms.**  
 High quality and efficient solution for high temperature refrigeration down to 8 °C.

**Panasonic offers one of the widest ranges in HVAC&R and DHW solutions on the market, enabling us to provide the most suitable system for any application, 24 hours a day, 365 days a year.**

**Our solutions ensure not only higher customer satisfaction but also lower energy consumption and reduced operating costs.**

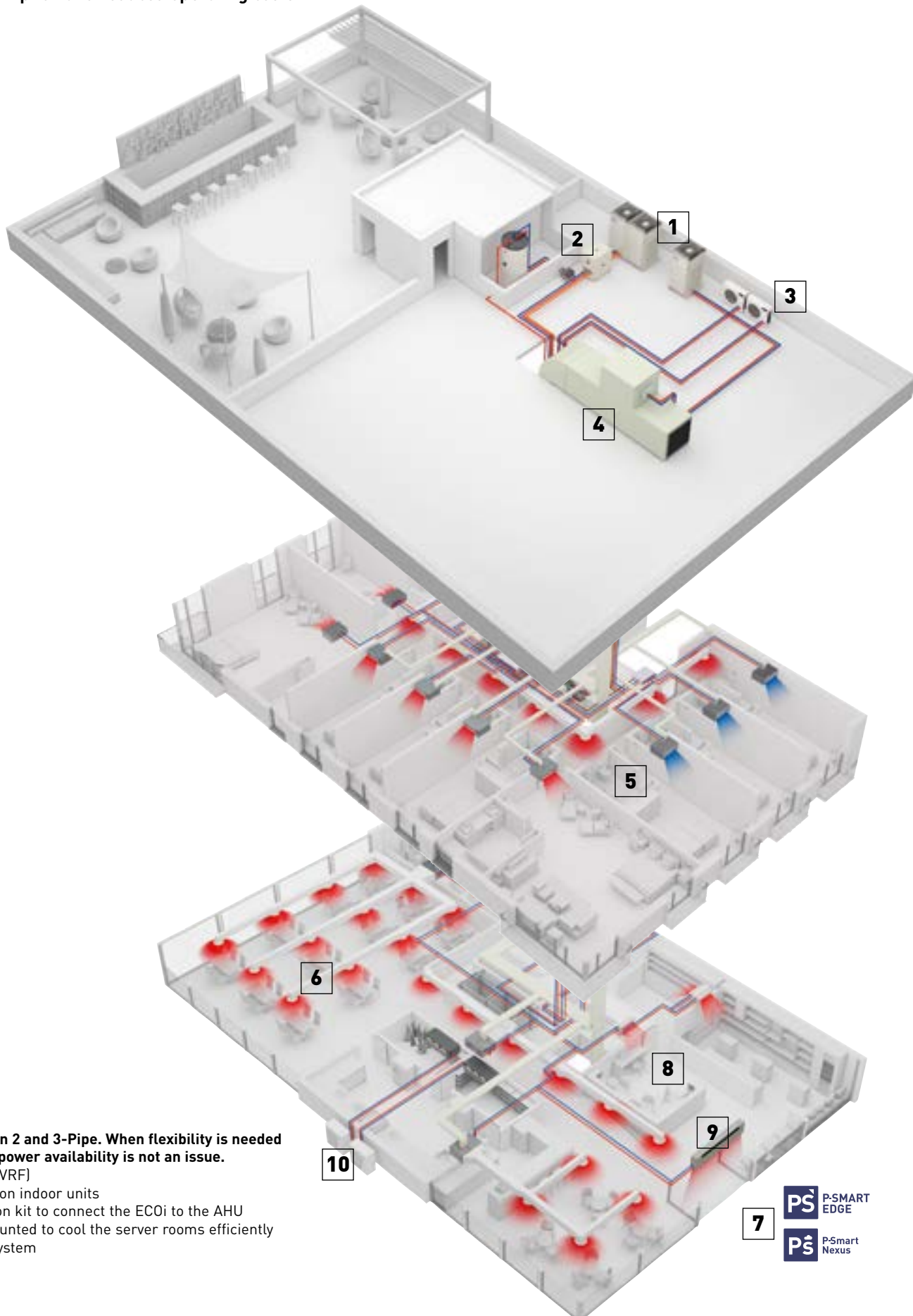

**Electric solution 2 and 3-Pipe. When flexibility is needed and electricity power availability is not an issue.**

- ECOi (electric VRF)
- Direct expansion indoor units
- AHU connection kit to connect the ECOi to the AHU
- YKEA wall-mounted to cool the server rooms efficiently
- Pump Down system



# Innovative solutions for retail

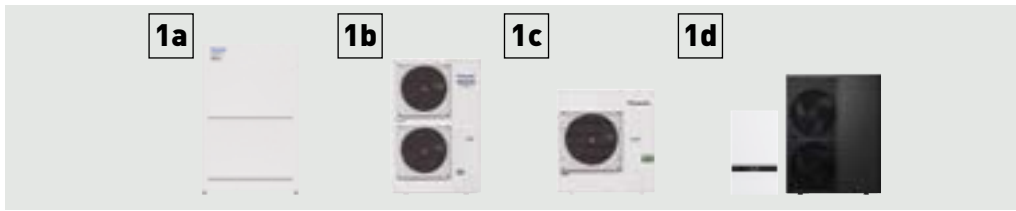

**Multi energy solutions.**

The Multi energy solution from Panasonic provides the best choice in energy saving and on the flexibility of the installation. Panasonic solutions can be connected to direct expansion systems, water chiller installations and ventilation systems as air handling units.

- 1a: VRF. ECOi
- 1b: VRF. Mini ECOi
- 1c: 1x1. PACi NX
- 1d: A2W. Aquarea



**YKEA unit for server room.**

Steady cooling, nonstop, even at -25 °C and still with high-efficiency. Ready for continuous operation and easy to connect 2 systems to automatically alternate and ensure server rooms are kept cool.



**Control your way.**

Wide variety of controls, from simple user control to full system control via remote access functionality. Touch panel and consumption control.



**Econavi sensor.**

The Econavi sensor detects presence in the room, and quietly adapts the PACi or VRF air conditioning system in order to improve comfort and energy savings.

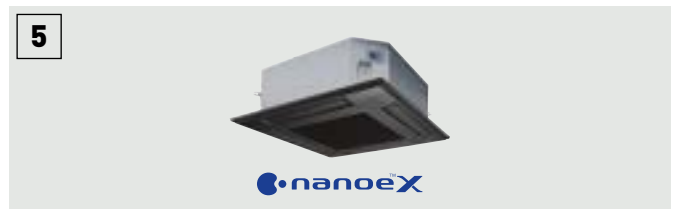

**Wide range of indoor units.**

All units provided with supply air temperature sensor and low operation sound level to guarantee maximum guest comfort. Units equipped with nanoe™ X (available in specific models) provide better air quality in public spaces in the hotel.



**Hide-away, for power and efficiency.**

Super silent units from 1,0 kW offer precise temperature control for small rooms. M2 type ultra-slim ducted units, only 200 mm high, fit in height-restricted spaces.



**Air curtain with DX coil.**

Designed for smooth operation and efficient performance.



**Commercial Smart Edge.**

Manage the entire Panasonic HVAC portfolio across multi-site installations from a single platform, remotely, 24/7.



**Protocol friendly.**

Great flexibility for integration into your KNX / Modbus / LonWorks / BACnet projects allows fully bi-directional monitoring and control of all the functioning parameters. Range of solutions to control locally or remotely the full system in bi-directional mode.



**AHU connection kit for efficient ventilation.**

The AHU connection kit is specially designed to improve the efficiency of the pre-heating or pre-cooling process of the ventilation.

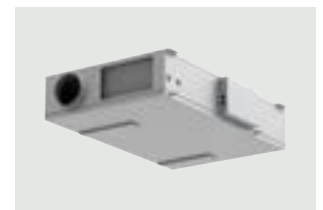

**Energy Recovery unit for high-efficiency of the system.**

Panasonic Energy Recovery Ventilators can reduce the outside air load because they efficiently recover the heat lost by ventilation during the heat recovery process.

## Heating and cooling solutions for retail applications.

Panasonic has developed solutions for retail and office applications where return on investment is a key factor! The comfort inside the shop is key for a good customer experience.







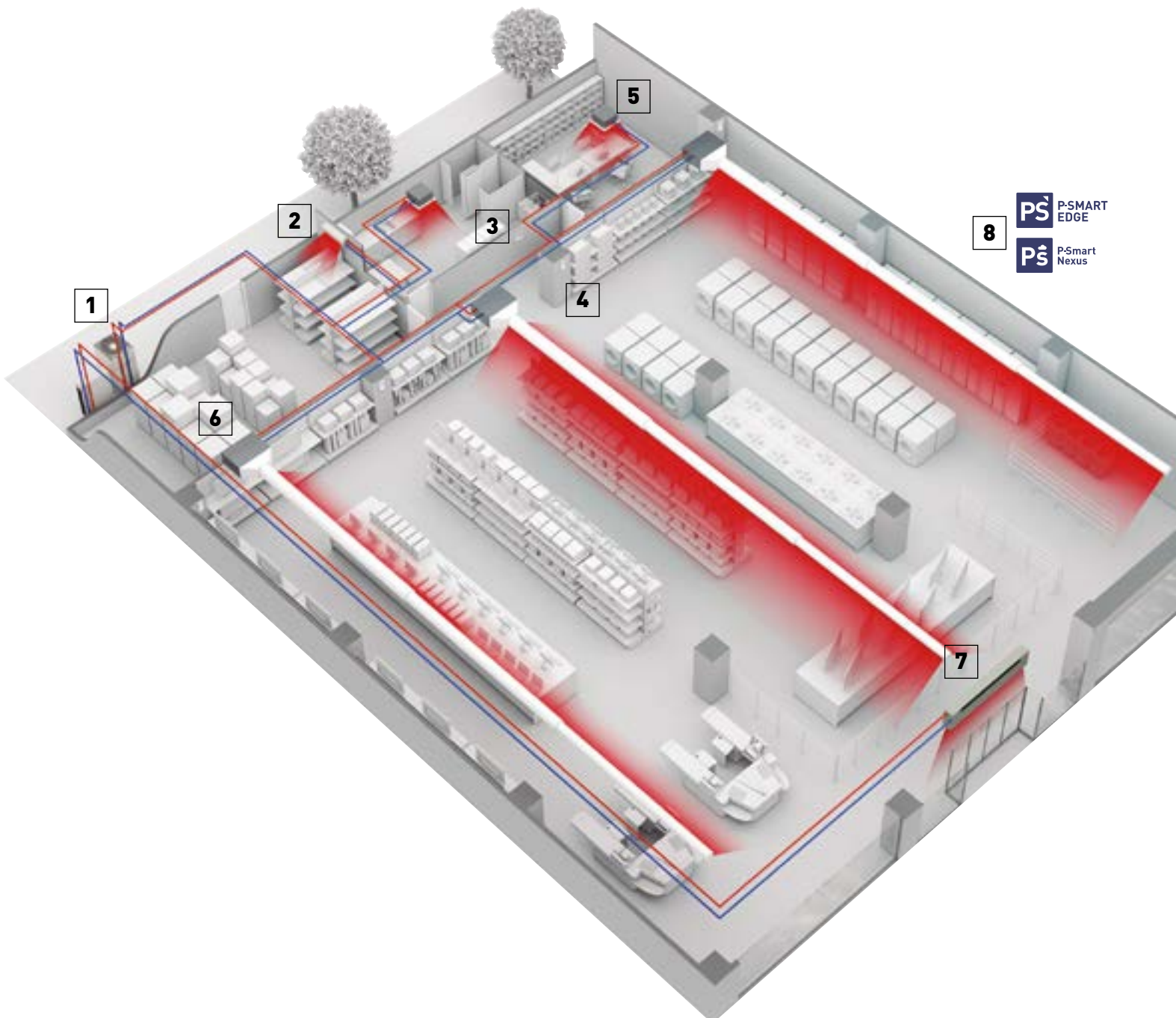









From local control or Panasonic's cloud control system, a detailed status of the heating and cooling system can be displayed, analysed and optimised in order to improve the efficiency, reduce the running time and increase the life time of the units.

### 8 reason why Panasonic is the best solution for your retail:

- Complete solution
- Flexibility and adaptability
- Go green retail: low CO<sub>2</sub> emissions
- Comfort - high customer satisfaction
- Future expansion
- Panasonic offers efficient systems meeting expectations over the life-span of the project
- High quality of service with Panasonic pro-partner installation team
- The system maintains operation by bypassing up to 25% of units during power failure

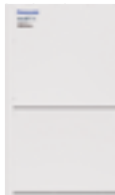
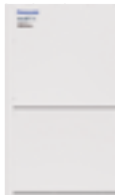

# VRF outdoor units range

Page	Outdoor units	4 HP	5 HP	6 HP	8 HP	10 HP
P. 22	<p>R32</p> <p>Mini ECOi LZ2 Series · R32</p>	 U-4LZ2E5 / U-4LZ2E8	 U-5LZ2E5 / U-5LZ2E8	 U-6LZ2E5 / U-6LZ2E8	 U-8LZ2E8	 U-10LZ2E8
P. 26	<p>Mini ECOi LE2 / LE1 Series · R410A</p>	 U-4LE2E5 / U-4LE2E8	 U-5LE2E5 / U-5LE2E8	 U-6LE2E5 / U-6LE2E8	 U-8LE1E8	 U-10LE1E8
P. 35	<p>R32</p> <p>2-Pipe ECOi EX MZ1 Series · R32</p>				 U-8MZ1E8	 U-10MZ1E8
P. 39	<p>R32</p> <p>NEW! 3-Pipe ECOi EX MF4 Series · R32</p>				 U-8MF4E8	 U-10MF4E8
P. 45	<p>2-Pipe ECOi EX ME2 Series · R410A</p>				 U-8ME2E8	 U-10ME2E8
P. 54	<p>3-Pipe ECOi EX MF3 Series · R410A</p>				 U-8MF3E8	 U-10MF3E8

12 HP

14 HP

16 HP

18 HP

20 HP



U-12MZ1E8



U-12MF4E8



U-12ME2E8



U-14ME2E8



U-16ME2E8



U-18ME2E8



U-20ME2E8



U-12MF3E8



U-14MF3E8



U-16MF3E8

# Mini ECOi LZ2 Series R32

Outstanding efficiency in a compact body and continuous operation even at extreme ambient temperatures. VRF with outstanding energy saving performance and superior SEER and SCOP.

R32  
REFRIGERANT



**EXTRAORDINARY SAVINGS.**  
SEER 8,50 <sup>1)</sup>  
SCOP 5,05 <sup>1)</sup>

**RELIABLE QUALITY - R32 STANDARD-COMPLIANT <sup>2)</sup>**

**PANASONIC DNA COMPRESSORS**

**LOW HEIGHT 996 MM**

**35Pa ESP**  
**HIGH EXTERNAL STATIC PRESSURE 35 PA**

**QUIET MODE OPERATION WITH LOW CAPACITY DROP**

**CONTINUOUS OPERATION AT EXTREME AMBIENT TEMPERATURES**  
52°C  
-20°C

**150%**  
**INCREASED INDOOR / OUTDOOR CAPACITY RATIO UP TO 150%**

1) for 4 HP model. 2) Panasonic's R32 safety measures comply with IEC 60335-2-40 (ed. 7.0) and EN 378 (ISO 5149).

## Mini ECOi LZ2 provides the optimal performance in any climatic condition.

### Extended design operation conditions

LZ2 mini VRF is extremely reliable even under the most difficult conditions. The units can operate in cooling mode at extreme temperatures, 52 °C in cooling and -20 °C in heating mode.

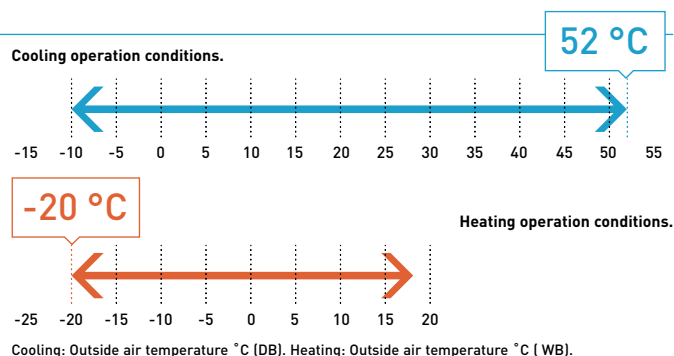

### Compatible with a large range of indoor units and controls

An expansion of Panasonic VRF line up, the Mini ECOi R32 is compatible with a large range of indoor units, either supporting Panasonic's optional R32 refrigerant leak detector alarm or having built-in detectors provide a great flexibility for all types of installation, and can utilize all Panasonic's scalable control and monitoring solutions.

#### Connects R32 refrigerant leak detector - CZ-CGLSC2



#### Built-in R32 sensors

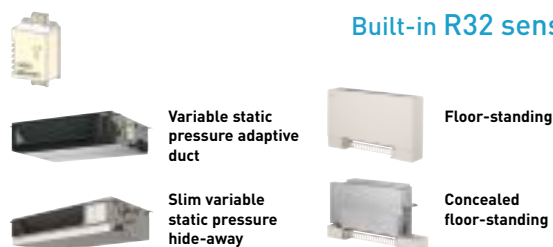

### Panasonic R32 refrigerant leak detector/alarm (optional)

The optional R32 refrigerant leak detector (CZ-CGLSC2) is available for compatible indoor units, allowing customers to determine if the detector is required for safety compliance or if the indoor unit can be installed without it. This sensor includes an integrated alarm buzzer and can connect to a central alarm system. It links to the indoor unit's remote control terminals and is compatible with any VRF remote controllers, wired or wireless.

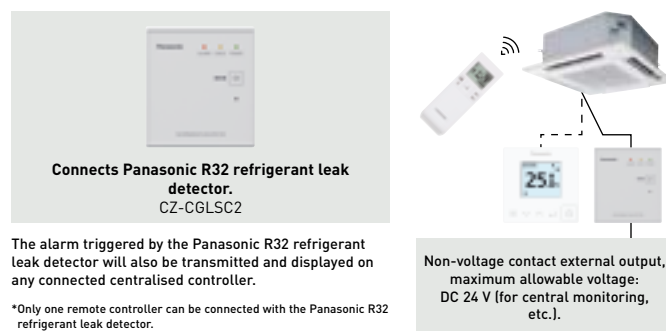

### R32 Pump Down solution

R32 Pump Down solution offers the assurance of additional safety protection, whilst expanding the potential installation cases, allowing for installation within smaller rooms. Suitable for the Mini ECOi LZ2 range up to 10 HP, compatible indoor units connected to CZ-CGLSC2 or integrated Panasonic R32 refrigerant leak detector.

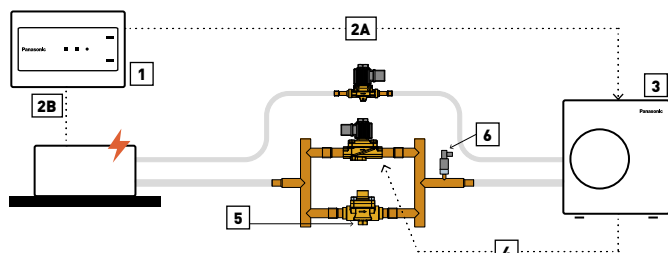

Operation steps: 1 | A leak is detected by the leak detection sensor. 2A | Leak alarm signal is sent to the outdoor unit. 2B | Indoor unit fan activated and runs at maximum speed. 3 | Pump Down procedure is activated. 4 | Solenoid valves are closed preventing refrigerant returning to indoor units. 5 | Outdoor unit is operating in Pump Down mode and check valve only allows flow to the outdoor unit. 6 | Low pressure switch threshold is reached. Error signal isolates the outdoor unit, preventing restart.

### Technical focus

- Simplified design and installation
- Complies with IEC 60335-2-40 ed.6.0
- Recovers base charge within outdoor unit
- Expands potential installation cases
- IP rated connections for outdoor installation

Model reference	Description
PAW-PUD2WB-1	Basic Pump Down system (2 way) for one R32 Mini ECOi outdoor unit

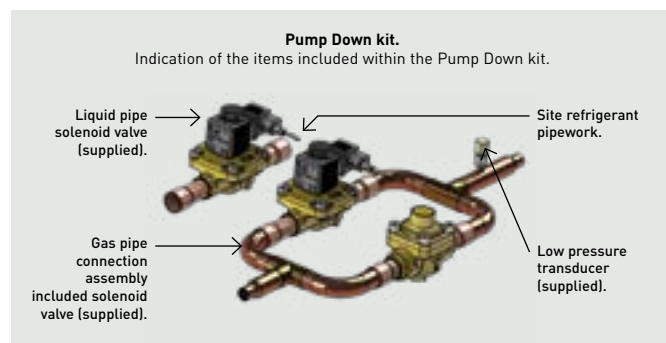

## Mini ECOi LZ2 Series 4 to 6 HP - R32

**Outstanding efficiency in a compact body and continuous operation even at extreme ambient temperatures.**

- SEER levels up to 8,5 and SCOP levels up to 5,0 (for 4 HP model)
- Continuous operation at extreme ambient temperatures: -20 °C (heating) to 52 °C (cooling)
- Unique indoors with nanoe™ X, hydroxyl radicals contained in water

Low height  
996 mm



HP			4 HP	5 HP	6 HP	4 HP	5 HP	6 HP
Outdoor unit			U-4LZ2E5	U-5LZ2E5	U-6LZ2E5	U-4LZ2E8	U-5LZ2E8	U-6LZ2E8
Power supply	Voltage	V	220-230-240	220-230-240	220-230-240	380-400-415	380-400-415	380-400-415
	Phase		Single phase	Single phase	Single phase	Three phase	Three phase	Three phase
	Frequency	Hz	50	50	50	50	50	50
Cooling capacity		kW	12,1	14,0	15,5	12,1	14,0	15,5
EER <sup>1)</sup>		W/W	4,53	4,12	3,88	4,53	4,12	3,88
Current		A	13,30-12,80-12,20	16,90-16,20-15,50	19,60-18,70-18,00	4,37-4,15-4,00	5,50-5,23-5,04	6,44-6,12-5,89
Input power		kW	2,67	3,40	4,00	2,67	3,40	4,00
Heating capacity		kW	12,5	16,0	16,5	12,5	16,0	16,5
COP <sup>1)</sup>		W/W	5,27	4,71	4,42	5,27	4,71	4,42
Current		A	12,00-11,40-11,00	16,90-16,20-15,50	18,50-17,70-17,00	3,91-3,71-3,58	5,50-5,22-5,03	6,02-5,72-5,51
Input power		kW	2,37	3,40	3,73	2,37	3,40	3,73
Starting current		A	1,0	1,0	1,0	1,0	1,0	1,0
Maximum current		A	19,6	23,7	26,5	7,2	9,2	9,9
Maximum input power		kW	3,92-4,10-4,28	4,76-4,98-5,19	5,41-5,66-5,90	4,40-4,63-4,80	5,69-5,99-6,22	6,15-6,47-6,72
Maximum number of connectable indoor units <sup>2)</sup>			7(10)	8(12)	9(12)	7(10)	8(12)	9(12)
External static pressure		Pa	0-35	0-35	0-35	0-35	0-35	0-35
Air flow		m <sup>3</sup> /min	69	72	74	69	72	74
Sound pressure	Cool	dB(A)	52	53	54	52	53	54
	Cool (Silent 1/2/3/4)	dB(A)	49/47/45/45	50/48/46/45	51/49/47/45	49/47/45/45	50/48/46/45	51/49/47/45
	Heat	dB(A)	54	56	56	54	56	56
Sound power	Cool / Heat	dB(A)	69/72	70/74	72/75	69/72	70/74	72/75
Dimension	H x W x D	mm	996 x 980 x 370	996 x 980 x 370	996 x 980 x 370	996 x 980 x 370	996 x 980 x 370	996 x 980 x 370
Net weight		kg	94	94	94	94	94	94
Piping diameter	Liquid	Inch (mm)	3/8(9,52)	3/8(9,52)	3/8(9,52)	3/8(9,52)	3/8(9,52)	3/8(9,52)
	Gas	Inch (mm)	5/8(15,88)	5/8(15,88)	5/8(15,88)	5/8(15,88)	5/8(15,88)	5/8(15,88)
Maximum piping length (total)		m	90(180)	90(180)	90(180)	90(180)	90(180)	90(180)
Elevation difference (in / out)		m	50(OU above)/ 40(OU below)	50(OU above)/ 40(OU below)	50(OU above)/ 40(OU below)	50(OU above)/ 40(OU below)	50(OU above)/ 40(OU below)	50(OU above)/ 40(OU below)
Refrigerant [R32]		kg	2,7	2,7	2,7	2,7	2,7	2,7
Maximum allowable indoor / outdoor capacity ratio <sup>3)</sup>		%	50-150(130)	50-150(130)	50-150(130)	50-150(130)	50-150(130)	50-150(130)
Operating range	Cool Min - Max	°C	-10-52	-10-52	-10-52	-10-52	-10-52	-10-52
	Heat Min - Max	°C	-20-18	-20-18	-20-18	-20-18	-20-18	-20-18

### ErP data <sup>4)</sup>

SEER <sup>5)</sup>	8,50	8,12	7,71	8,50	8,12	7,71
$\eta_{s,c}$	337,0%	321,8%	305,4%	337,0%	321,8%	305,4%
SCOP <sup>5)</sup>	5,05	4,61	4,59	5,05	4,61	4,59
$\eta_{s,h}$	199,0%	181,4%	180,6%	199,0%	181,4%	180,6%

1) EER and COP calculation is based in accordance to EN 14511. 2) The number in parenthesis indicates maximum number of connectable indoor unit in case of 1,5 kW indoor units connection. 3) The number in parenthesis indicates maximum allowed indoor / outdoor capacity ratio in case of 1,5 kW indoor units connection. 4) SEER / SCOP and  $\eta_{s,c}$  /  $\eta_{s,h}$  are in accordance with ErP test data for U2 type 4 way 90x90 cassette indoor units. 5) SEER / SCOP is calculated based on the seasonal space cooling / heating efficiency "η" values of the COMMISSION REGULATION (EU) 2016/2281. SEER, SCOP = (η + Correction) × PEF.

### Minimum environmental impact

Panasonic has designed the LZ2 series in order to minimize the environmental impact of the system. Low GWP refrigerant R32 and highest efficiency levels ensure this through the total operational lifetime.

### For the most challenging spaces

The Mini ECOi LZ2 R32 VRF system is the ideal solution to fit into any application thanks to its compact design and long piping lengths.

### Technical focus

- Widest range of connectable units in R32 VRF
- Allowing wide range of installations with and without mitigation measures
- Flexible mitigation measures, with Panasonic R32 refrigerant leak detector / alarm to be installed only when required



INTERNET CONTROL: Optional.



Industry 1st 8 HP  
and 10 HP Mini VRF  
units with R32



### Mini ECOi LZ2 Series 8 and 10 HP - R32

#### Introducing widest range of R32 Mini VRF.

- SEER levels up to 7,6 and SCOP levels up to 4,6 (for 8 HP model)
- Continuous operation at extreme ambient temperatures: -20 °C (heating) to 52 °C (cooling)
- Unique indoors with nanoe™ X, hydroxyl radicals contained in water

HP			8 HP	10 HP
Outdoor unit			U-8LZ2E8	U-10LZ2E8
Power supply	Voltage	V	380-400-415	380-400-415
	Phase		Three phase	Three phase
	Frequency	Hz	50	50
Cooling capacity		kW	22,4	28,0
<b>EER</b> <sup>1)</sup>		W/W	3,84	3,47
Current		A	9,73-9,25-8,91	13,2-12,5-12,1
Input power		kW	5,83	8,07
Heating capacity		kW	25,0	28,0
<b>COP</b> <sup>1)</sup>		W/W	4,30	4,47
Current		A	9,81-9,32-8,98	10,5-9,93-9,57
Input power		kW	5,81	6,26
Starting current		A	1,0	1,0
Maximum current		A	13,7	19,5
Maximum input power		kW	8,21-8,64-8,96	11,9-12,6-13,0
Maximum number of connectable indoor units <sup>2)</sup>			16	16
External static pressure		Pa	0-35	0-35
Air flow		m <sup>3</sup> /min	158	167
Sound pressure	Cool	dB(A)	59,0	60,0
	Cool (Silent 1/2/3/4)	dB(A)	56/54/52/50	57/55/53/50
Sound power	Cool	dB(A)	72	74
Dimension	H x W x D	mm	1500 x 980 x 370	1500 x 980 x 370
Net weight		kg	125	126
Piping diameter	Liquid	Inch (mm)	3/8(9,52)	3/8(9,52)
	Gas	Inch (mm)	3/4(19,05)	7/8(22,22)
Maximum piping length (total)		m	100(300)	100(300)
Elevation difference (in / out)		m	50(OU above)/40(OU below)	50(OU above)/40(OU below)
Refrigerant (R32)		kg	4,9	5,1
Maximum allowable indoor / outdoor capacity ratio <sup>3)</sup>		%	50-150(130)	50-150(130)
Operating range	Cool Min ~ Max	°C	-10-52	-10-52
	Heat Min ~ Max	°C	-20-18	-20-18

#### ErP data<sup>4)</sup>

<b>SEER</b> <sup>5)</sup>	<b>7,56</b>	<b>7,08</b>
$\eta_{s,c}$	<b>299,4%</b>	<b>280,2%</b>
<b>SCOP</b> <sup>5)</sup>	<b>4,59</b>	<b>4,60</b>
$\eta_{s,h}$	<b>180,6%</b>	<b>181,0%</b>

1) EER and COP calculation is based in accordance to EN 14511. 2) The number in parenthesis indicates maximum number of connectable indoor unit in case of 1,5 kW indoor units connection. 3) The number in parenthesis indicates maximum allowed indoor / outdoor capacity ratio in case of 1,5 kW indoor units connection. 4) SEER / SCOP and  $\eta_{s,c}$  /  $\eta_{s,h}$  are in accordance with ErP test data for F2 type variable static pressure hide-away indoor units. 5) SEER / SCOP is calculated based on the seasonal space cooling / heating efficiency "η" values of the COMMISSION REGULATION (EU) 2016/2281. SEER, SCOP = (η + Correction) × PEF.

### Perfect fit for small to medium size projects

8 and 10 HP LZ2 Mini VRF units bring in the total benefits of a VRF system in a smaller application. You can enjoy advanced individual and central VRF control options including the revolutionary Panasonic AC Smart Cloud and AC Service Cloud.

### For the most difficult conditions

The Mini ECOi LZ2 series are able to operate at the hardest conditions from -20 °C up to +52 °C providing continuous and efficient, heating and cooling for your space all year long.

### Technical focus

- Widest range of connectable units in R32 VRF
- Allowing wide range of installations with and without refrigerant mitigation
- Flexible mitigation measures, with Panasonic R32 refrigerant leak detector / alarm to be installed only when required



INTERNET CONTROL: Optional.

Rating conditions: Cooling indoor 27 °C DB / 19 °C WB. Cooling outdoor 35 °C DB / 24 °C WB. Heating indoor 20 °C DB. Heating outdoor 7 °C DB / 6 °C WB. (DB: Dry Bulb; WB: Wet Bulb). Specifications subject to change without notice. For detailed information about ErP / Energy Labelling, please visit our websites [www.aircon.panasonic.eu](http://www.aircon.panasonic.eu) or [www.ptc.panasonic.eu](http://www.ptc.panasonic.eu).



# Mini ECOi LE Series R410A

Mini ECOi with extraordinary energy saving performance and high external static pressure (35Pa).



**EXTRAORDINARY SAVINGS.**  
SEER 7,85 <sup>1)</sup>  
SCOP 4,87 <sup>1)</sup>

**HIGH QUALITY - PANASONIC TWIN ROTARY COMPRESSOR**

**NO EXTRA REFRIGERANT NEEDED UP TO 50 M <sup>2)</sup>**

**HIGH COP MODE OPTION <sup>2)</sup>**

**LOW HEIGHT 996 MM**

**35Pa ESP HIGH EXTERNAL STATIC PRESSURE 35 PA**

**CONTINUOUS OPERATION AT EXTREME AMBIENT TEMPERATURES**  
46°C  
-20°C

**130% INCREASED INDOOR / OUTDOOR CAPACITY RATIO UP TO 130%**

1) for 4 HP model. 2) For model 4-6 HP.

### High external static pressure 35 Pa.

- High air pressure
- An efficient blade design
- Perfect for high class condominiums

When unit is installed on a narrow balcony and exposed to the sun, the barrier at the front side may restrict hot air from being discharged. Heat accumulated in an enclosure can cause over-heating. This may potentially result in damage or shorten the product's life span. A high external static pressure fan sends the air further away from the outdoor unit and through the barrier. This provides better air circulation and distribution.

And a high air pressure of 35 Pa discharges the hot air to a sufficient distance.

Previous model - low pressure.

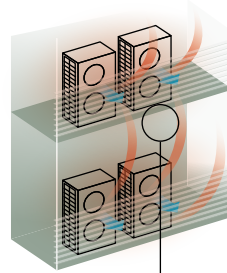

**Heat accumulated.**  
When the pressure is low, hot air will accumulate in the unit thus affecting its work performance and that of unit above it as well.



Previous fan

LE Series - high pressure.

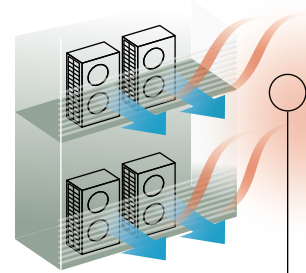

**Heat discharged.**  
But with a high pressure of 35 Pa, hot air is sent further away preventing overheating inside the outdoor unit enclosure.



LE2's fan

### Energy control and reliability

The Mini ECOi system delivering energy saving performance, powerful operation, reliability and comfort surpassing anything previously possible.



3 layers

#### Powerful heat exchanger.

3 layers of heat exchanger for all LE Series. LE Series features the same heat exchange volume as conventional model even though it is 15% smaller in size.



#### Panasonic twin rotary compressor.

A large capacity Inverter compressor has been adopted. This compressor features wider and 0,1 Hz step Inverter control.

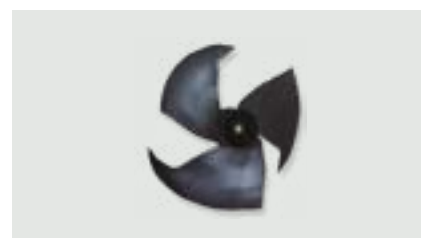

#### Design fan.

Fan blades have been redesigned to inhibit air resistance and to increase efficiency. The larger fan increases air flow while maintaining low noise levels.

### Energy savings design

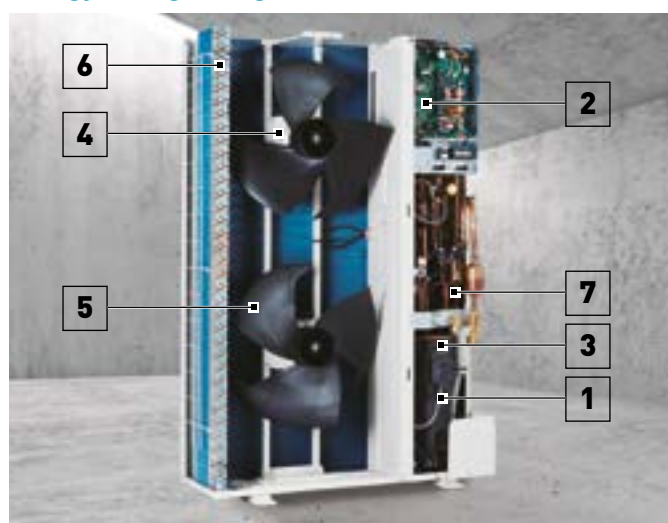

- 1 | Panasonic Inverter compressor.** A large-capacity Inverter compressor has been adopted. The Inverter compressor is superior in performance with improved partial-load capacity.
- 2 | Printed circuit board.** Maintenance is made easier with only 2 PCBs.
- 3 | Accumulator.** A large accumulator has been adopted to maintain compressor reliability because of the increased refrigerant quantity, which allows an extended maximum piping length.
- 4 | DC fan motor.** Checking load and outside temperature, the DC motor is controlled for optimum air flow.
- 5 | Blade shape.** The fan blades have been developed to inhibit air turbulence and increase efficiency. As the fan diameter has been increased, air flow has also increased whilst maintaining a same sound level.
- 6 | Heat exchanger and copper tubes.** Optimised heat exchanger and copper tube sizes enhance efficiency. Bluefin condenser with anti-corrosion treatment ensures durability in salty and rust-prone environments.
- 7 | Oil separator.** A centrifugal separator has been adopted to improve oil separation efficiency and reduce refrigerant pressure loss.

### Maximum comfort with quiet operation mode

- Quiet operation mode reduces outdoor unit operating sound by 7 dB(A)
- 4-step set point is available
- Silent mode 1 maintains rated cooling capacity

\*Timer setting of quiet operation mode is available in high-spec remote controller.

Silent mode options	Sound pressure level
Silent mode 1	-1,5 dB(A)
Silent mode 2	-3 dB(A)
Silent mode 3	-5 dB(A)
Silent mode 4	-7 dB(A)

**Mini ECOi LE2 Series high-efficiency 4 to 6 HP · R410A****Panasonic Mini ECOi. Extraordinary energy saving.**

The most compact ECOi system ever.

- Outstanding SEER and SCOP
- Better efficiency even compared to 2 fan outdoor units



HP			4 HP	5 HP	6 HP	4 HP	5 HP	6 HP
Outdoor unit			U-4LE2E5	U-5LE2E5	U-6LE2E5	U-4LE2E8	U-5LE2E8	U-6LE2E8
Power supply	Voltage	V	220-230-240	220-230-240	220-230-240	380-400-415	380-400-415	380-400-415
	Phase		Single phase	Single phase	Single phase	Three phase	Three phase	Three phase
	Frequency	Hz	50	50	50	50	50	50
Cooling capacity		kW	12,1	14,0	15,5	12,1	14,0	15,5
EER <sup>1)</sup>		W/W	4,50	4,06	3,73	4,50	4,06	3,73
Current		A	13,30-12,70-12,20	16,30-15,60-17,00	20,30-19,40-18,60	4,39-4,17-4,02	5,58-5,30-5,11	6,71-6,37-6,14
Input power		kW	2,69	3,45	4,15	2,69	3,45	4,15
Heating capacity		kW	12,5	16,0	16,5	12,5	16,0	16,5
COP <sup>1)</sup>		W/W	5,19	4,60	4,27	5,19	4,60	4,27
Current		A	12,20-11,60-11,20	17,60-16,80-16,10	19,10-18,20-17,50	3,98-3,78-3,64	5,62-5,34-5,14	6,24-5,93-5,71
Input power		kW	2,41	3,48	3,86	2,41	3,48	3,86
Starting current		A	1,00	1,00	1,00	1,00	1,00	1,00
Maximum current		A	17,30	24,30	27,40	7,90	10,10	10,70
Maximum input power		kW	3,50-3,66-3,82	4,92-5,14-5,37	5,61-5,86-6,12	4,34-5,09-5,28	6,25-6,55-6,82	6,62-6,97-7,23
Maximum number of connectable indoor units <sup>2)</sup>			7(10)	8(10)	9(12)	7(10)	8(10)	9(12)
External static pressure		Pa	0-35	0-35	0-35	0-35	0-35	0-35
Air flow		m <sup>3</sup> /min	69	72	74	69	72	74
Sound pressure	Cool	dB(A)	52	53	54	52	53	53
	Cool (Silent 1/2/3/4)	dB(A)	50,5/49/47/45	51,5/50/48/46	52,5/51/48/46	50,5/49/49/47	48,5/50/48/46	48,5/50/48/46
	Heat	dB(A)	54	56	56	54	56	56
Sound power	Cool / Heat	dB(A)	69/72	71/75	73/75	69/72	71/75	73/75
Dimension	H x W x D	mm	996 x 980 x 370	996 x 980 x 370	996 x 980 x 370	996 x 980 x 370	996 x 980 x 370	996 x 980 x 370
Net weight		kg	106	106	106	106	106	106
Piping diameter	Liquid	Inch (mm)	3/8(9,52)	3/8(9,52)	3/8(9,52)	3/8(9,52)	3/8(9,52)	3/8(9,52)
	Gas	Inch (mm)	5/8(15,88)	5/8(15,88)	5/8(15,88)	5/8(15,88)	5/8(15,88)	5/8(15,88)
Maximum piping length (total)		m	150(180)	150(180)	150(180)	150(180)	150(180)	150(180)
Elevation difference (in / out)		m	50(OU above)/ 40(OU below)	50(OU above)/ 40(OU below)	50(OU above)/ 40(OU below)	50(OU above)/ 40(OU below)	50(OU above)/ 40(OU below)	50(OU above)/ 40(OU below)
Refrigerant (R410A) / CO <sub>2</sub> Eq.		kg / T	6,70(14,40)/ 13,9896	6,70(14,40)/ 13,9896	6,70(14,40)/ 13,9896	6,70(14,40)/ 13,9896	6,70(14,40)/ 13,9896	6,70(14,40)/ 13,9896
Maximum allowable indoor / outdoor capacity ratio		%	50-130	50-130	50-130	50-130	50-130	50-130
Operating range	Cool Min - Max	°C	-10 ~ +46	-10 ~ +46	-10 ~ +46	-10 ~ +46	-10 ~ +46	-10 ~ +46
	Heat Min - Max	°C	-20 ~ +18	-20 ~ +18	-20 ~ +18	-20 ~ +18	-20 ~ +18	-20 ~ +18

**ErP data<sup>3)</sup>**

SEER <sup>4)</sup>	<b>7,85</b>	<b>7,48</b>	<b>7,25</b>	<b>7,85</b>	<b>7,48</b>	<b>7,25</b>
$\eta_{s,c}$	<b>311,0%</b>	<b>296,2%</b>	<b>286,8%</b>	<b>311,0%</b>	<b>296,2%</b>	<b>286,8%</b>
SCOP <sup>4)</sup>	<b>4,87</b>	<b>4,40</b>	<b>4,24</b>	<b>4,87</b>	<b>4,40</b>	<b>4,24</b>
$\eta_{s,h}$	<b>191,8%</b>	<b>172,9%</b>	<b>166,7%</b>	<b>191,8%</b>	<b>172,9%</b>	<b>166,7%</b>

1) EER and COP calculation is based in accordance to EN 14511. 2) In case of 1,5 kW indoor units connection, able to connect maximum 12 indoor units. 3) SEER / SCOP and  $\eta_{s,c}$  /  $\eta_{s,h}$  are in accordance with ErP test data for F2 type variable static pressure hide-away indoor units. 4) SEER / SCOP is calculated based on the seasonal space cooling / heating efficiency "η" values of the COMMISSION REGULATION (EU) 2016/2281. SEER, SCOP = (η + Correction) × PEF.

**For light commercial use**

Mini ECOi allows easier installation in condominiums and medium sized buildings with limited spaces. Utilising R410A and DC Inverter technology, Panasonic offers VRF to a new and growing market.

**Technical focus**

- 50 m piping without additional refrigeration charge
- High static pressure 35 Pa
- High COP mode selectable with maintenance remote controller
- Selectable silent mode

**Reduced height of 996 mm**

In addition to raising efficiency, the outdoor unit has been designed to be as compact as possible. It can now be installed in places that were previously too small.



INTERNET CONTROL: Optional.





### Mini ECOi LE1 Series high-efficiency 8 and 10 HP - R410A

#### Prepare to be blown away by Panasonic's Mini VRF system.

The Mini VRF compact system is the ideal solution for minimum outdoor space.

Panasonic extends the Mini VRF range by 8 and 10 HP units.

- Piping flexibility with 150 m maximum length
- High-efficiency

HP			8 HP	10 HP
Outdoor unit			U-8LE1E8	U-10LE1E8
Power supply	Voltage	V	380-400-415	380-400-415
	Phase		Three phase	Three phase
	Frequency	Hz	50	50
Cooling capacity		kW	22,4	28,0
EER <sup>1)</sup>		W/W	3,80	3,11
Current		A	9,60-9,15-8,80	14,70-14,00-13,50
Input power		kW	5,89	9,00
Heating capacity		kW	25,0	28,0
COP <sup>1)</sup>		W/W	4,02	3,93
Current		A	10,20-9,65-9,30	11,60-11,10-10,70
Input power		kW	6,22	7,13
Starting current		A	1,00	1,00
Maximum current		A	13,70	19,60
Maximum input power		kW	9,16	13,10
Maximum number of connectable indoor units <sup>2)</sup>			15	15
External static pressure		Pa	0-35	0-35
Air flow			150	160
Sound pressure	Cool	dB(A)	60	63
	Cool (Silent 1/2/3)	dB(A)	57/55/53	60/58/56
	Heat	dB(A)	64	65
Sound power	Cool / Heat	dB(A)	81/85	84/86
Dimension	H x W x D	mm	1500 x 980 x 370	1500 x 980 x 370
Net weight			132	133
Piping diameter	Liquid	Inch (mm)	3/8 [9,52] <sup>3)</sup> / 1/2 [12,70] <sup>4)</sup>	3/8 [9,52] <sup>3)</sup> / 1/2 [12,70] <sup>4)</sup>
	Gas	Inch (mm)	3/4 [19,05] <sup>3)</sup> / 7/8 [22,22] <sup>4)</sup>	7/8 [22,22] <sup>3)</sup> / 1 [25,40] <sup>4)</sup>
Maximum piping length (total)			7,5-150 [7,5-300]	7,5-150 [7,5-300]
Elevation difference (in / out)			50 [OU above] / 40 [OU below]	50 [OU above] / 40 [OU below]
Refrigerant (R410A) / CO <sub>2</sub> Eq.			6,30 [24,00] / 13,1544	6,60 [24,00] / 13,7808
Maximum allowable indoor / outdoor capacity ratio			50-130	50-130
Operating range	Cool Min ~ Max	°C	-10 ~ +46	-10 ~ +46
	Heat Min ~ Max	°C	-20 ~ +18	-20 ~ +18

#### ErP data<sup>5)</sup>

SEER <sup>6)</sup>	<b>6,27</b>	<b>6,37</b>
$\eta_{s,c}$	<b>247,9%</b>	<b>251,8%</b>
SCOP <sup>6)</sup>	<b>4,24</b>	<b>4,31</b>
$\eta_{s,h}$	<b>166,4%</b>	<b>169,5%</b>

1) EER and COP calculation is based in accordance to EN 14511. 2) If the heating utilized, it is necessary to increase 1 size with respect to the main liquid pipe, depending on the combination of the indoor unit. 3) Under 90 m for ultimate indoor unit. 4) Over 90 m for ultimate indoor unit. If the longest piping equivalent length exceeds 90 m, increase the sizes of the main tubes by 1 rank for gas and liquid pipes. 5) SEER / SCOP and  $\eta_{s,c}$  /  $\eta_{s,h}$  are in accordance with ErP test data for F2 type variable static pressure hide-away indoor units. 6) SEER / SCOP is calculated based on the seasonal space cooling / heating efficiency "η" values of the COMMISSION REGULATION (EU) 2016/2281. SEER, SCOP = (η + Correction) × PEF.

### Increase external static pressure

When unit is installed on a narrow balcony, any barrier in front will be an obstacle. High external static pressure will overcome this obstacle and maintain operating capacity.

### Technical focus

- Connection of up to 15 indoor units
- Quiet operation mode (one of the lowest in the market)
- High ambient temp performance
- High static pressure 35 Pa

### High ambient temperature performance

Cooling operation range up to 46 °C. The system can maintain the rated (100%) capacity up to 40 °C by 8 HP model and up to 37 °C by 10 HP model.



INTERNET CONTROL: Optional.

Rating conditions: Cooling indoor 27 °C DB / 19 °C WB. Cooling outdoor 35 °C DB / 24 °C WB. Heating indoor 20 °C DB. Heating outdoor 7 °C DB / 6 °C WB. (DB: Dry Bulb; WB: Wet Bulb). Specifications subject to change without notice. For detailed information about ErP / Energy Labelling, please visit our websites [www.aircon.panasonic.eu](http://www.aircon.panasonic.eu) or [www.ptc.panasonic.eu](http://www.ptc.panasonic.eu).



## ECO*i* EX range

ECO*i* EX range system delivering energy saving performance, powerful operation, reliability and comfort surpassing anything previously possible. Taking quality to the extreme — that's the Panasonic challenge.

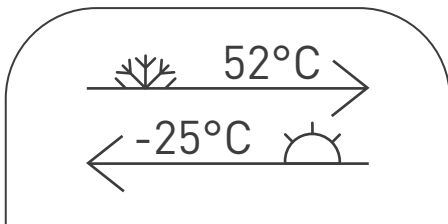

### High performance at extreme conditions.

ECO*i* EX delivers reliable cooling up to 52 °C and heating down to -25 °C, ensuring strong performance even in extreme conditions. Bluefin-coated heat exchangers enhance efficiency in marine environments, while a silicone-coated PCB protects against moisture and dust\*.

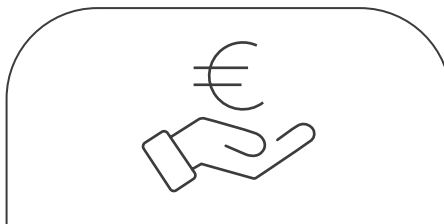

### Outstanding efficiency and comfort.

- High SEER and efficient part-load performance
- All-inverter compressors with independent control for lower energy use
- Triple-surface heat exchanger + curved bell-mouth for improved efficiency
- Three-stage oil-recovery system reduces forced oil recovery and energy costs

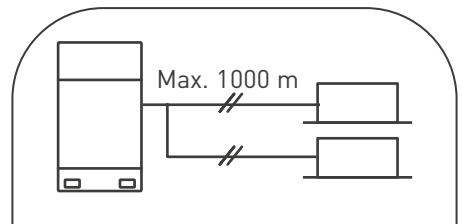

### Superior flexibility.

- Up to 1000 m piping length\*
- 100 m maximum outdoor-to-indoor distance
- Wide indoor unit range for perfect project adaptation
- 30 m maximum indoor-to-indoor height difference
- Indoor/outdoor connected capacity ratio up to 200%
- Optimized with Pump Down, AHU and hydronic modules.

\*Conditions of 2-Pipe ECO*i* EX ME2 and MZ1 Series.

### Trusted reliability even under high and low temperature conditions.

Designed to be durable enough to withstand extreme heat, 2-Pipe ECOi EX Series ensures reliable cooling operation over an extended operating range up to 52 °C, and heating operation also at -25 °C.

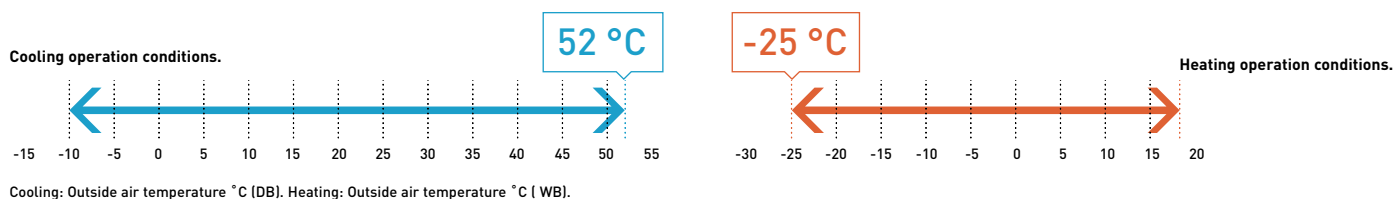

### Maximum allowable connected indoor / outdoor capacity ratio up to 200%\*

ECOi EX attain maximum indoor unit connection capacity of up to 130% of the unit's connection range. This limit can be surpassed and reach up to 200% if some conditions are satisfied. With this feature, ECOi EX provides an ideal air conditioning solution for locations where full cooling / heating are not always required in all spaces at same time.

System (HP)	8	10	12	14	16	18	20	22	24	26	28	30	32	34	36	38	40	42	44	46	48	50	52	54	56	58	60	62	64	66	68	70	72	74	76	78	80			
Connectable indoor units: 130%	13	16	19	23	26	29	33	36	40	43	46	50	53	56	59															64										
Connectable indoor units: 200%	20	25	30	35	40	45	50	55	60											64																				

Note: If more than 100% indoor units are operated with a high load, the units may not perform at the rated capacity. For the details, please consult with an authorised Panasonic dealer. \*If the following conditions are satisfied, the effective range is above 130% up to 200%. Obey the limited number of connectable indoor units. The lower limit of operating range for heating outdoor temperature is limited to -10 °C WB (standard -25 °C WB). Simultaneous operation is limited to less than 130% of connectable indoor units. 1.5 kW capacity of Indoor Units are included. System range availability depends on the series.

### Increased piping lengths and design flexibility

Adaptable to various building types and sizes. Actual piping length: 200 m. Maximum piping length: 1000 m.

- 1) 40 m if the outdoor unit is below the indoor unit.
- 2) For height differences between outdoor unit and indoor unit > 50 m, as well as for height differences between indoor units > 15 m, contact an authorized Panasonic dealer.

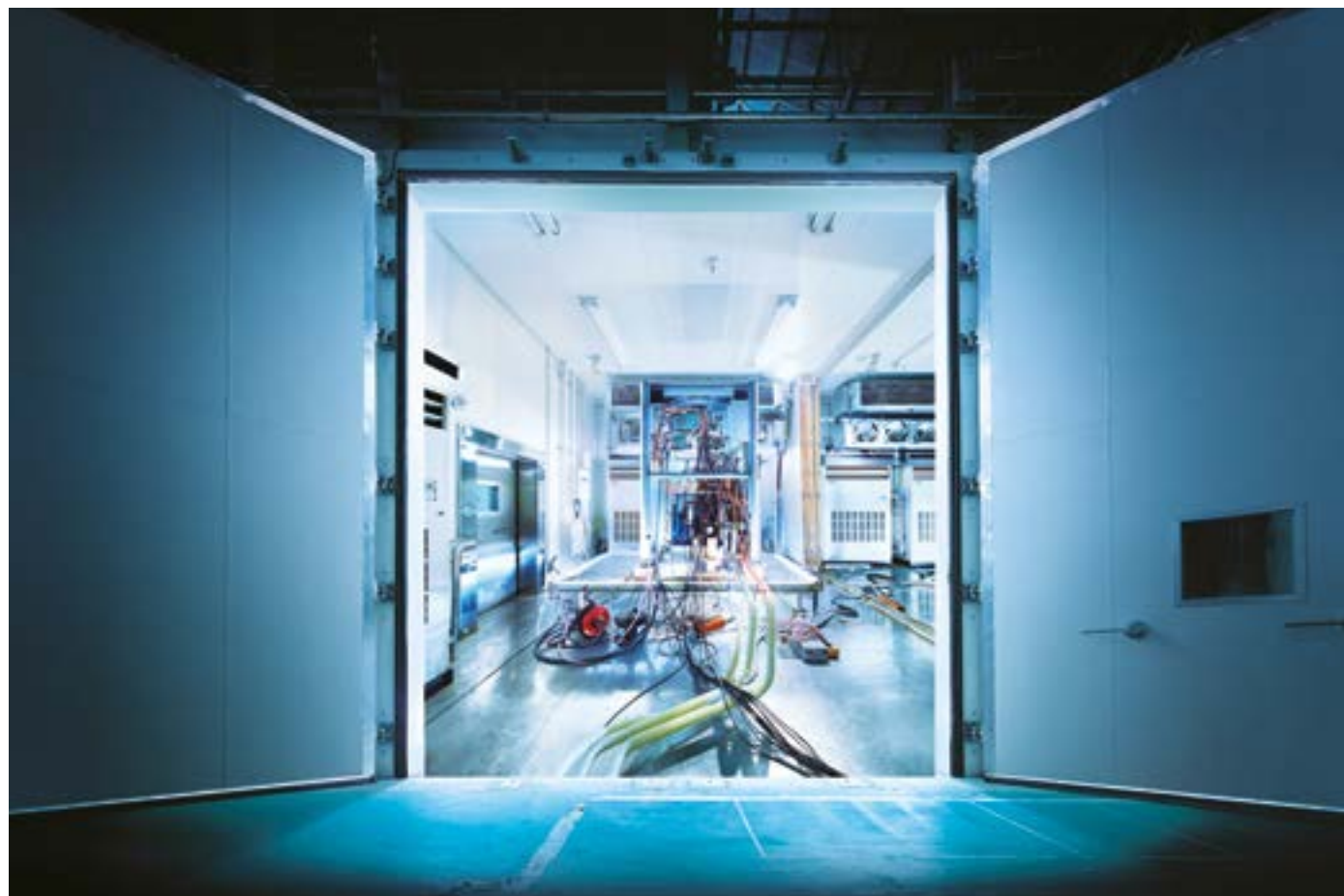
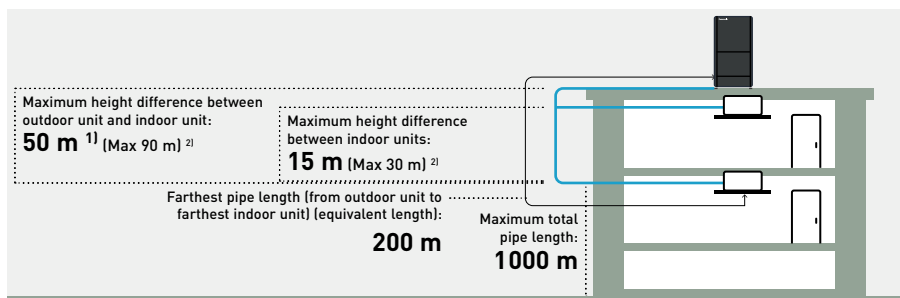

# Superior quality, reliability and durability

High-quality components are selected to deliver exceptional energy savings and ensure long-lasting performance.

**Invest in quality. Prioritise safety. Choose ECOi EX Series.**



R32 MZ1 Series

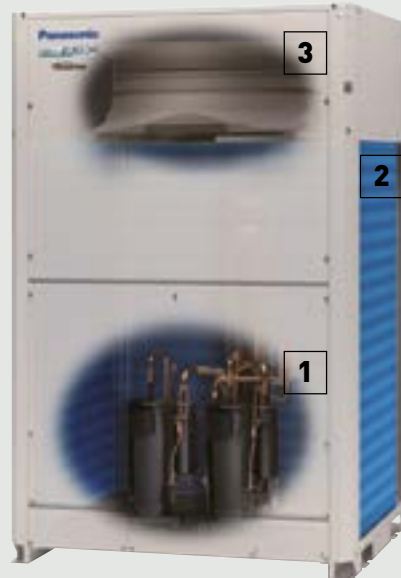

R410A ME2/MF3 Series

1

## High-efficiency refrigerant circuit.

### Panasonic Inverter-driven compressor.

Inverter-driven compressor equipped, to optimise high-efficiency operation year-round.

- MZ1 Series: Inverter-driven scroll compressor
- ME2/MF3 Series: Inverter-driven rotary compressor

### Accumulator.

Oil returning circuit with control valve makes efficient oil recovery to compressors.

### Oil separator.

Modified tank design makes efficient oil separation with less pressure drop.



### Receiver tank-less design.

Improved refrigerant control program recovers the remaining refrigerant gas in the system back to the accumulator tank effectively.

2

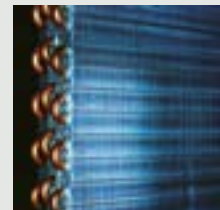

## Enlarged heat exchanger surface area with triple rows.

The unit has become more compact while maintaining high equivalent efficiency, thanks to the enlarged heat exchanger surface area with triple rows\*.

\*Subject to model specifications.

## Anti-corrosion Bluefin treatment.

High corrosion resistance to rust and salty air for lasting performance.

3

## Smooth exhaust flow by bell-mouth.

Specially designed curved air discharge bell-mouth for better aerodynamics.

4

## Grey panel colour.

The grey panel colour of the outdoor unit allows it to blend in and be installed discreetly on a wide variety of installations.

5

## 7-segment display.

7-segment display for ease of user installation, commissioning, service and maintenance.

# Oil recovery intelligent control

Oil recovery intelligent control advantages: higher efficiency, durability and comfort (continuous operation, low noise and low vibration).

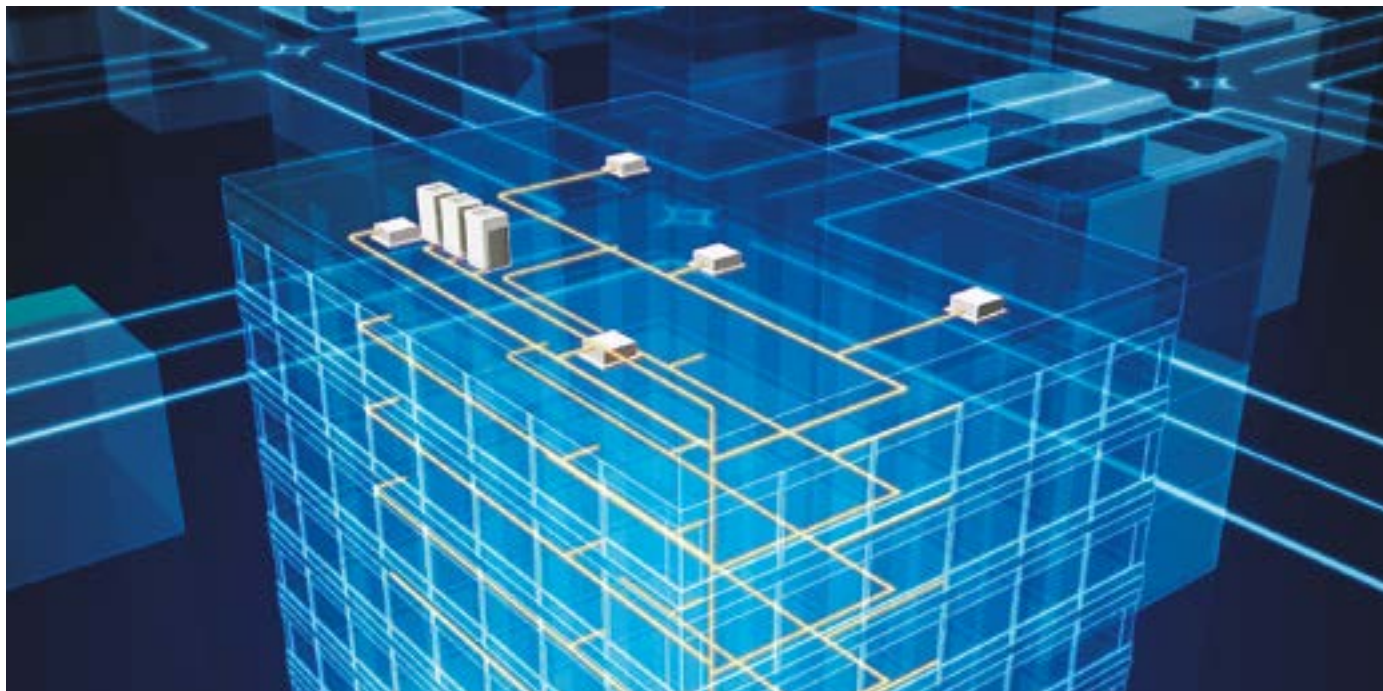

## Intelligent 3-stage oil management system

In a VRF system, where lengthy piping and a large number of indoor units need to be controlled collectively, the key to maintaining the system's reliability is to ensure an appropriate amount of oil is secured in the compressors. In order to avoid oil shortage in the compressor, maximum operation is normally forcibly conducted at regular intervals to recover oil from indoor units. This method, typically employed in a standard VRF, causes the system to overheat or overcool and thus waste energy. In Panasonic VRF systems, a sensor for detecting oil levels is mounted in each compressor. In installations with multiple outdoor units, a shortage of oil in one compressor can be compensated for by recovering oil either from another compressor in the same unit, from a compressor in an adjacent outdoor unit, or from connected indoor units. Panasonic VRF systems provide users with a comfortable environment whilst saving energy.

**The Panasonic system efficiently manages oil recovery in three stages; minimising the frequency of forced oil recovery while reducing energy cost and maintaining comfort.**

**STAGE-1:** Panasonic compressors are equipped with sensors which monitor oil levels precisely at all times. If oil levels fall, oil can be transferred from other compressors within the same outdoor unit\*.

**STAGE-2:** If oil levels in all compressors within the outdoor unit fall, oil can be replenished from adjacent outdoor units.

**STAGE-3:** Forced oil recovery is implemented only if oil levels become insufficient in spite of above measures. The Panasonic system's design concept is radically different from conventional oil systems.

\*Applicable to ECOi EX outdoor units over 14 HP (2-compressor models).

## Features of oil recovery design

### Oil sensors installed in each compressor\*.

Oil sensors installed in each Panasonic compressor precisely monitor oil levels, eliminating unnecessary oil recovery.

\*Applicable to ECOi EX outdoor units over 14 HP (2-compressor models).

### Highly functional oil separator.

Thanks to extended separate piping, oil recovery efficiency reaches 90%, minimising the oil discharged from the compressor.



# ECOi EX range R32

**Extreme efficiency, quality, compact.**

The ECOi EX Series with R32 refrigerant has been expanded to minimise the environmental impact of VRF Systems for the decarbonised buildings.



**Advanced R32 technology and optimised design make it a more sustainable alternative to R410A.**

With lower GWP and superior efficiency, it ensures sustainability throughout its lifetime.



	2-Pipe ECOi EX MZ1 Series	3-Pipe ECOi EX MF4 Series
Capacity range	8 HP – 48 HP	8 HP – 36 HP
High seasonal efficiency ( $\eta_{s,c} / \eta_{s,h}$ )	310,1% – 172,4% <sup>1)</sup>	308,3% – 171,0% <sup>2)</sup>
Extended operation range	-25 °C in heating to +52 °C in cooling	-20 °C in heating to +52 °C in cooling
Flexible piping installation	1000 m	500 m

1) U-10MZ1E8. 2) U-10MF4E8.



1) Panasonic's R32 safety measures comply with IEC 60335-2-40 (ed. 7.0) and EN 378 (ISO 5149). 2) Compared to R410A systems.

## ECOi EX range R32.

Enjoy greater installation flexibility and cost savings.

### High-efficiency in a compact outdoor unit

Significantly reduced volume and a lightweight chassis help reduce design and installation work.

MZ1 Series seasonal efficiency.

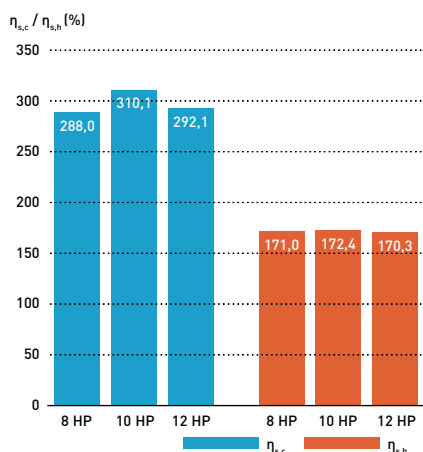

MF4 Series seasonal efficiency.

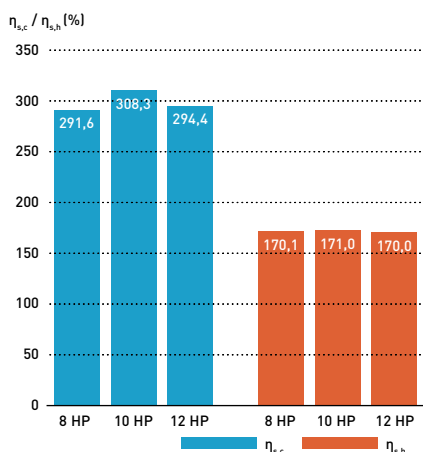

Volume reduction.

-49% <sup>1)</sup>



1) 12 HP model compared to the equivalent conventional R410A ECOi EX model. 2) 8 and 10 HP models.

Compact and light weight.

203 kg <sup>2)</sup>

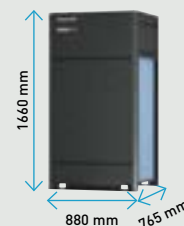

### R32 safety measures by Panasonic.

#### Everything necessary for R32 refrigerant safety is prepared by Panasonic.

Panasonic provides safety measure compliant with the latest standards, as required based on R32 refrigerant density under specific project conditions.

The safety measures which comply with EN 378 (ISO 5149) and IEC 60335-2-40 (ed. 7.0).

#### Leak detector – CZ-CGLSC2.

Leak detector designed for 4 way 90x90 cassettes, 4 way 60x60 cassettes, and wall-mounted units.



#### Leak alarm – CZ-CGLALC1.

R32 refrigerant leak alarm designed for adaptive duct, slim duct, floor standing and concealed floor standing.



#### External power supply – PAW-16DC-ALC1.

External 16 V power supply [EN 378 compliant], including a leak alarm for remote locations. The leak alarm can be deactivated.



#### 2-pipe safety valve kit – CZ-P1160SVK.

The safety valve manages the shutdown of only the area / zone experiencing a refrigerant leak, instead of shutting down the whole 2-pipe ECOi EX system.



#### 3-pipe heat recovery box with safety valve kit – CZ-P1160SVHR.

Single-port heat recovery box for the 3-pipe ECOi EX system. The safety valve manages the shutdown of only the area / zone experiencing a refrigerant leak, instead of shutting down the whole system.



#### 3-pipe heat recovery box – CZ-P1160HR4.

Standard single-port heat recovery box for the 3-pipe ECOi EX system.



#### Example of how R32 safety measures work in an HVAC system.

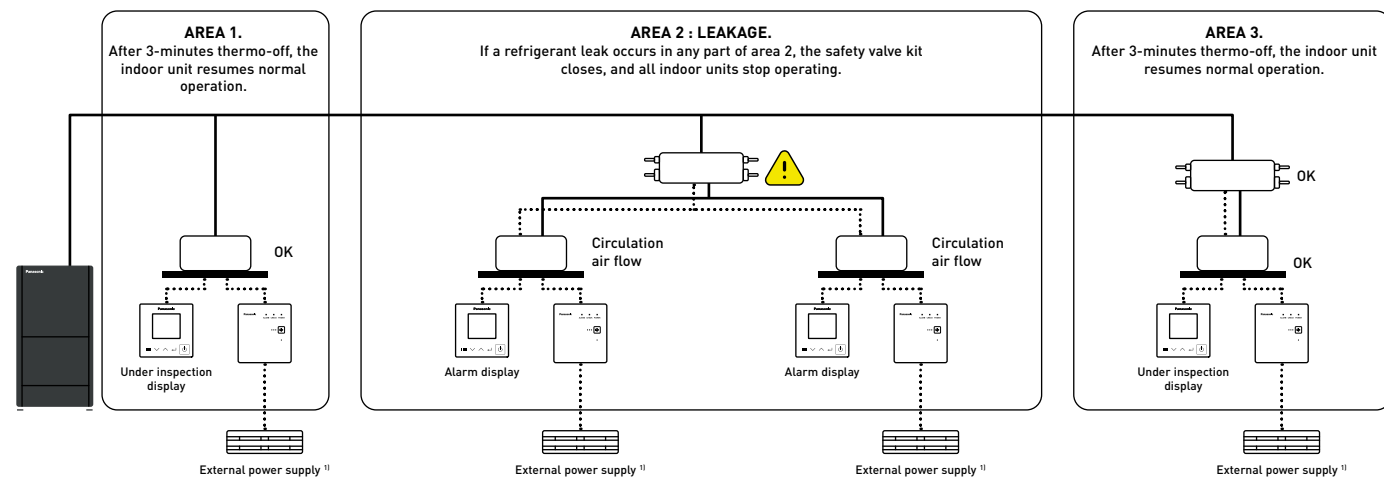

\*A maximum of 1 leak detector can be connected per indoor unit or group. If a leak detector is connected, only 1 wired remote controller is allowed (no sub-controller). Up to 8 units, including indoor units and a safety valve, can be connected. 1) In accordance with EN 378-3, alarm systems such as external leak detectors and safety alarms require a power source independent of the air conditioning system they are protecting. In addition, they must have a backup power source and be able to alert a monitored location. For further information, please contact an authorised Panasonic dealer.

# 2-Pipe ECOi EX MZ1 Series R32

## Core features.

### Maximum comfort with silent operation mode

Thanks to the optimised bell mouth design, sound pressure can be reduced to as low as 54 dB(A)\* in silent mode while maintaining high cooling capacity.

\*For model U-8MZ1E8.

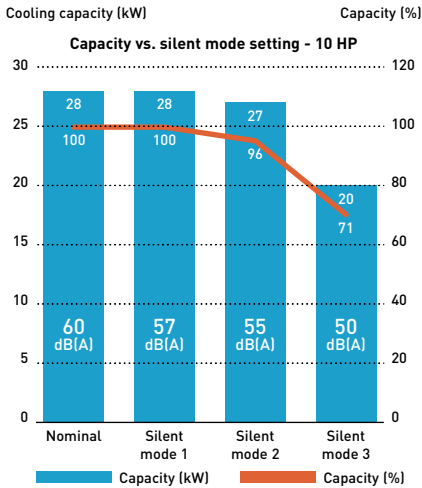

- Silent operation mode reduces outdoor unit noise down to 50 dB(A)
- 3-step set point available
- Silent mode 1 maintains rated 100% cooling capacity

Noise (SPL)	8 HP	10 HP	12 HP
Nominal	57 dB(A)	60 dB(A)	64 dB(A)
Silent mode 1	54 dB(A)	57 dB(A)	61 dB(A)
Silent mode 2	52 dB(A)	55 dB(A)	59 dB(A)
Silent mode 3	50 dB(A)	50 dB(A)	50 dB(A)

### Improved bell mouth design.

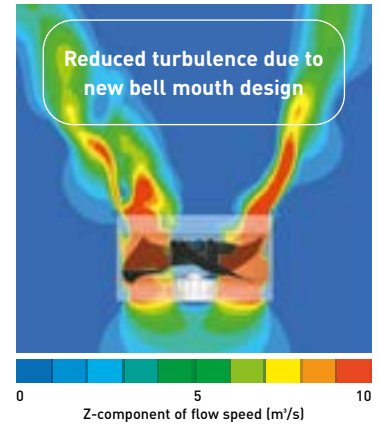

### Wide operating limits

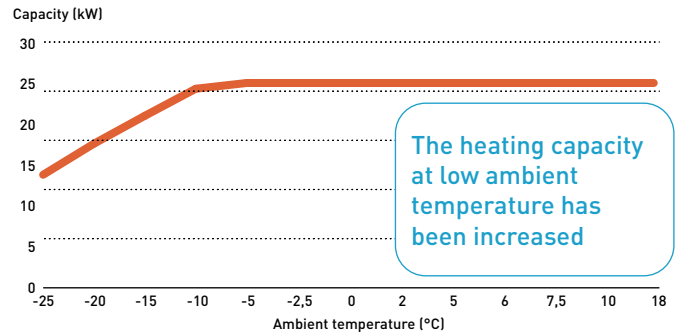
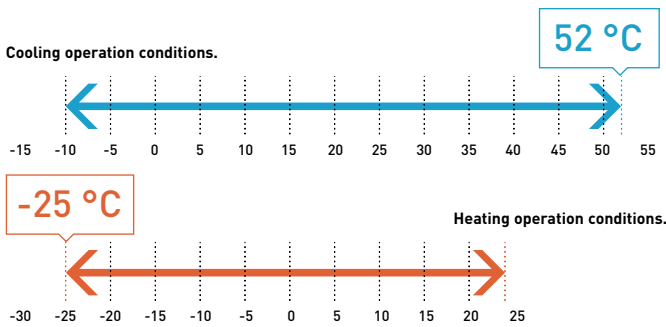

Cooling: Outside air temperature °C (DB). Heating: Outside air temperature °C (WB).

\*Maximum capacity unaffected by defrost operation.

### Reduced refrigerant charge, lowering the requirements for additional safety measures and piping material choice

The new MZ1 Series uses only 57%\* of the R32 refrigerant compared to the R410A equivalent system and supports imperial or metric piping installation.

\*Panasonic's internal research. 12 HP model with 30 m piping installation.



\*Panasonic's internal research. 12 HP model with 30 m piping installation.

### Increased piping lengths and design flexibility

Adaptable to various building types and sizes. Actual piping length: 200 m. Maximum piping length: 1000 m.

- 1) 40 m if the outdoor unit is below the indoor unit.
- 2) For height differences between outdoor unit and indoor unit > 50 m, as well as for height differences between indoor units > 15 m, contact an authorized Panasonic dealer.

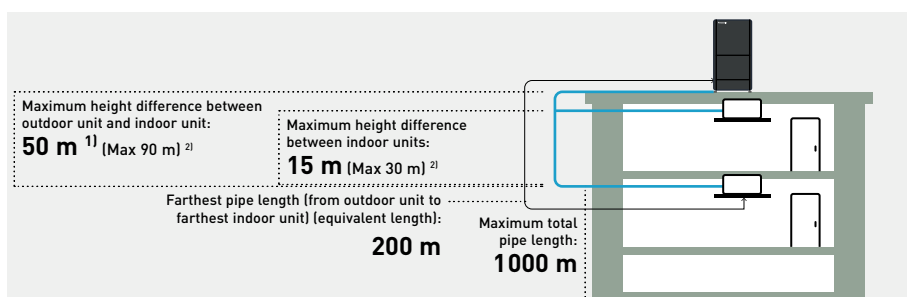



## 2-Pipe ECOi EX MZ1 Series - R32

### Extreme efficiency, quality, compact.

With advanced R32 refrigerant technology and optimised system design.

Wide operation range from -25 °C in heating to +52 °C in cooling.

HP			8 HP	10 HP	12 HP
Outdoor unit			U-8MZ1E8	U-10MZ1E8	U-12MZ1E8
Power supply	Voltage	V	380-400-415	380-400-415	380-400-415
	Phase		Three phase	Three phase	Three phase
	Frequency	Hz	50	50	50
Cooling capacity		kW	22,4	28,0	33,5
EER <sup>1)</sup>		W/W	3,30	3,50	3,00
Current		A	11,70-11,10-10,70	13,50-12,80-12,40	18,30-17,40-16,80
Input power		kW	6,78	8,00	11,1
Heating capacity		kW	25,0	31,5	37,5
COP <sup>1)</sup>		W/W	4,50	4,30	4,00
Current		A	9,81-9,32-8,98	12,50-11,90-11,50	15,70-14,90-14,40
Input power		kW	5,55	7,32	9,37
Starting current		A	1,00	1,00	1,00
External static pressure (Max)		Pa	80	80	80
Air flow		m <sup>3</sup> /min	209	209	209
Sound pressure	Normal mode (Cool / Heat)	dB(A)	57/57	60/60	64/67
	Silent mode 1 / 2 / 3 (Cool)	dB(A)	54/52/50	57/55/50	61/59/50
Sound power	Normal mode (Cool / Heat)	dB(A)	75/75	77/77	81/84
Dimension	HxWxD	mm	1660x880x765	1660x880x765	1660x880x765
Net weight		kg	203	203	206
Piping diameter <sup>2)</sup>	Liquid	Inch (mm)	3/8(9,52)/1/2(12,70)	3/8(9,52)/1/2(12,70)	3/8(9,52)/1/2(12,70)
	Gas	Inch (mm)	3/4(19,05)/7/8(22,22)	3/4(19,05)/7/8(22,22)	7/8(22,22)/1-1/8(28,58)
	Balance	Inch (mm)	1/4(6,35)	1/4(6,35)	1/4(6,35)
Refrigerant (R32) / CO <sub>2</sub> Eq		kg/T	6,30/4,25	6,40/4,32	8,50/5,74
Maximum allowable indoor / outdoor capacity ratio <sup>3)</sup>		%	50-200(130)	50-200(130)	50-200(130)
Operating range	Cool Min ~ Max	°C	-10 ~ +52	-10 ~ +52	-10 ~ +52
	Heat Min ~ Max	°C	-25 ~ +24	-25 ~ +24	-25 ~ +24
<b>ErP data <sup>4)</sup></b>					
SEER <sup>5)</sup>			<b>7,27</b>	<b>7,82</b>	<b>7,37</b>
$\eta_{s,c}$			<b>288,0%</b>	<b>310,1%</b>	<b>292,1%</b>
SCOP <sup>5)</sup>			<b>4,35</b>	<b>4,38</b>	<b>4,33</b>
$\eta_{s,h}$			<b>171,0%</b>	<b>172,4%</b>	<b>170,3%</b>

1) EER and COP calculation is based in accordance to EN 14511. 2) Piping diameter under 100 m for ultimate indoor unit / over 100 m for ultimate indoor unit (if the longest piping equivalent length exceeds 100 m, increase the sizes of the main tubes by 1 rank for gas tubes and liquid tubes). 3) If the following conditions are satisfied, the effective range is above 130% and below 200%: A. Obey the limited number of connectable indoor units. B. The lower limit of operating range for heating outdoor temperature is limited to -10 °C WB (standard -25 °C WB). C. Simultaneous operation is limited to less than 130% of connectable indoor units. 4) SEER / SCOP and  $\eta_{s,c}$  /  $\eta_{s,h}$  are in accordance with ErP test data for U2 type 4 way 90x90 cassette indoor units. 5) SEER / SCOP is calculated based on the seasonal space cooling / heating efficiency " $\eta$ " values of the COMMISSION REGULATION (EU) 2016/2281. SEER, SCOP = ( $\eta$  + Correction) × PEF.

## Technical focus

- 8-10 HP available in single systems, with scalability up to 48 HP in multi-combination systems
- Optional R32 refrigerant safety measures available
- Compact outdoor unit with up to 43% <sup>1)</sup> smaller footprint and 49% reduced volume
- Full heating capacity maintained down to -5 °C ambient temperature
- Uses only 57% <sup>2)</sup> of the R32 refrigerant charge required by an equivalent R410A system, reducing the need for additional safety measures
- Bluefin-coated heat exchanger as standard
- Extensive R32 product range, with all air to air indoor units equipped with nanoe™ X
- Broad solution compatibility, including Energy Recovery Ventilation (ERV) and Air Handling Unit (AHU) connection kits
- Wide range of connectivity options, including BMS integration for seamless system control and monitoring

1) 12 HP model compared to the equivalent conventional R410A ECOi EX ME2.

2) Panasonic's internal research. 12 HP model with 30 m piping installation.



## 2-Pipe ECOi EX MZ1 Series combination from 16 to 48 HP - R32

HP			16 HP	18 HP	20 HP	20 HP	22 HP	24 HP	24 HP	26 HP
			U-8MZ1E8	U-8MZ1E8	U-8MZ1E8	U-10MZ1E8	U-10MZ1E8	U-12MZ1E8	U-8MZ1E8	U-8MZ1E8
	Outdoor unit		U-8MZ1E8	U-10MZ1E8	U-12MZ1E8	U-10MZ1E8	U-12MZ1E8	U-12MZ1E8	U-8MZ1E8	U-8MZ1E8
Power supply	Voltage	V	380-400-415	380-400-415	380-400-415	380-400-415	380-400-415	380-400-415	380-400-415	380-400-415
	Phase		Three phase	Three phase	Three phase	Three phase	Three phase	Three phase	Three phase	Three phase
	Frequency	Hz	50	50	50	50	50	50	50	50
Cooling capacity		kW	44,8	50,4	55,9	56,0	61,5	67,0	67,2	72,8
EER <sup>1)</sup>		W/W	3,20	3,40	3,10	3,50	3,20	3,00	3,20	3,30
SEER <sup>2)</sup> / η <sub>sc</sub>			<b>7,24/286,8%</b>	<b>7,56/299,6%</b>	<b>7,29/288,9%</b>	<b>7,82/310,1%</b>	<b>7,55/299,1%</b>	<b>7,33/290,2%</b>	<b>7,24/286,8%</b>	<b>7,46/295,6%</b>
Current		A	23,40-22,20-21,40	25,20-23,90-23,10	30,00-28,50-27,50	27,00-25,60-24,80	31,80-30,20-29,20	36,60-34,80-33,60	35,10-33,30-32,10	36,90-35,00-33,80
Input power		kW	13,6	14,8	17,9	16,0	19,1	22,2	20,4	21,6
Heating capacity		kW	50,0	56,5	62,5	63,0	69,0	75,0	75,0	81,5
COP <sup>1)</sup>		W/W	4,50	4,30	4,10	4,20	4,10	3,90	4,40	4,40
SCOP <sup>2)</sup> / η <sub>sh</sub>			<b>4,32/169,8%</b>	<b>4,33/170,3%</b>	<b>4,29/168,8%</b>	<b>4,38/172,2%</b>	<b>4,34/170,7%</b>	<b>4,33/170,2%</b>	<b>4,32/169,8%</b>	<b>4,31/169,5%</b>
Current		A	19,62-18,64-17,96	22,31-21,22-20,48	25,51-24,22-23,38	25,00-23,80-23,00	28,20-26,80-25,50	31,40-29,80-28,80	29,43-27,96-26,94	32,12-30,54-29,46
Input power		kW	11,1	12,9	15,0	14,7	16,7	18,8	16,7	18,5
Starting current		A	1,00	1,00	1,00	1,00	1,00	1,00	1,00	1,00
External static pressure (Max)		Pa	80	80	80	80	80	80	80	80
Air flow		m <sup>3</sup> /min	418	418	418	418	418	418	627	627
Sound pressure	Normal mode (Cool / Heat)	dB(A)	60,0/60,0	62,0/62,0	65,0/67,5	63,0/63,0	65,5/68,0	67,0/70,0	62,0/62,0	63,0/63,0
	Silent mode 1 / 2 (Cool)	dB(A)	57,0/55,0	59,0/57,0	62,0/60,0	60,0/58,0	62,5/60,5	64,0/62,0	59,0/57,0	60,0/58,0
Sound power	Normal mode (Cool / Heat)	dB(A)	78,0/78,0	79,5/79,5	82,0/84,5	80,0/80,0	82,5/85,0	84,0/87,0	80,0/80,0	80,5/80,5
Dimension	H x W x D	mm	1660 x 1760 (+60) x 765	1660 x 1760 (+60) x 765	1660 x 1760 (+60) x 765	1660 x 1760 (+60) x 765	1660 x 1760 (+60) x 765	1660 x 1760 (+60) x 765	1660 x 2640 (+120) x 765	1660 x 2640 (+120) x 765
Net weight		kg	406	406	409	406	409	412	609	609
Piping diameter <sup>3)</sup>	Liquid	Inch (mm)	1/2(12,70)/ 5/8(15,88)	1/2(12,70)/ 5/8(15,88)	1/2(12,70)/ 5/8(15,88)	1/2(12,70)/ 5/8(15,88)	1/2(12,70)/ 5/8(15,88)	1/2(12,70)/ 5/8(15,88)	1/2(12,70)/ 5/8(15,88)	1/2(12,70)/ 5/8(15,88)
	Gas	Inch (mm)	1-1/8(28,58)/ 1-3/8(34,96)	1-1/8(28,58)/ 1-3/8(34,96)	1-1/8(28,58)/ 1-3/8(34,96)	1-1/8(28,58)/ 1-3/8(34,96)	1-1/8(28,58)/ 1-3/8(34,96)	1-1/8(28,58)/ 1-3/8(34,96)	1-1/8(28,58)/ 1-3/8(34,96)	1-1/8(28,58)/ 1-3/8(34,96)
	Balance	Inch (mm)	1/4(6,35)	1/4(6,35)	1/4(6,35)	1/4(6,35)	1/4(6,35)	1/4(6,35)	1/4(6,35)	1/4(6,35)
Refrigerant (R32) / CO <sub>2</sub> Eq.		kg / T	12,6/8,51	12,7/8,57	14,8/9,99	12,8/8,64	14,9/10,06	17,0/11,48	18,9/12,76	19,0/12,83
Maximum allowable indoor / outdoor capacity ratio <sup>4)</sup>		%	50 ~ 130(200)	50 ~ 130(200)	50 ~ 130(200)	50 ~ 130(200)	50 ~ 130(200)	50 ~ 130(200)	50 ~ 130(200)	50 ~ 130(200)
Operating range	Cool Min ~ Max	°C	-10 ~ +52	-10 ~ +52	-10 ~ +52	-10 ~ +52	-10 ~ +52	-10 ~ +52	-10 ~ +52	-10 ~ +52
	Heat Min ~ Max	°C	-25 ~ +24	-25 ~ +24	-25 ~ +24	-25 ~ +24	-25 ~ +24	-25 ~ +24	-25 ~ +24	-25 ~ +24

HP			28 HP	28 HP	30 HP	30 HP	32 HP	32 HP	32 HP	34 HP
			U-8MZ1E8	U-8MZ1E8	U-8MZ1E8	U-10MZ1E8	U-8MZ1E8	U-10MZ1E8	U-8MZ1E8	U-10MZ1E8
	Outdoor unit		U-8MZ1E8	U-10MZ1E8	U-12MZ1E8	U-10MZ1E8	U-12MZ1E8	U-12MZ1E8	U-8MZ1E8	U-12MZ1E8
Power supply	Voltage	V	380-400-415	380-400-415	380-400-415	380-400-415	380-400-415	380-400-415	380-400-415	380-400-415
	Phase		Three phase	Three phase	Three phase	Three phase	Three phase	Three phase	Three phase	Three phase
	Frequency	Hz	50	50	50	50	50	50	50	50
Cooling capacity		kW	78,3	78,4	83,9	84,0	89,4	89,5	89,6	95,0
EER <sup>1)</sup>		W/W	3,10	3,40	3,20	3,50	3,00	3,30	3,20	3,10
SEER <sup>2)</sup> / η <sub>sc</sub>			<b>7,23/286,3%</b>	<b>7,61/301,5%</b>	<b>7,45/295,1%</b>	<b>7,82/310,1%</b>	<b>7,26/287,4%</b>	<b>7,63/302,4%</b>	<b>7,24/286,8%</b>	<b>7,37/291,8%</b>
Current		A	41,70-39,60-38,20	38,70-36,70-35,50	43,50-41,30-39,90	40,50-38,40-37,20	48,30-45,90-44,30	45,30-43,00-41,60	46,80-44,40-42,80	50,10-47,60-46,00
Input power		kW	24,7	22,8	25,9	24,0	29,0	27,1	27,2	30,2
Heating capacity		kW	87,5	88,0	94,0	94,5	100,0	100,0	100,0	106,0
COP <sup>1)</sup>		W/W	4,20	4,30	4,20	4,20	4,10	4,10	4,50	4,00
SCOP <sup>2)</sup> / η <sub>sh</sub>			<b>4,34/170,9%</b>	<b>4,35/171,2%</b>	<b>4,33/170,4%</b>	<b>4,38/172,4%</b>	<b>4,31/169,6%</b>	<b>4,38/172,2%</b>	<b>4,32/169,8%</b>	<b>4,29/168,7%</b>
Current		A	35,32-33,54-32,36	34,81-33,12-31,98	38,01-36,12-34,88	37,50-35,70-34,50	41,21-39,12-37,78	40,70-38,70-37,40	39,24-37,28-35,92	43,90-41,70-40,30
Input power		kW	20,5	20,2	22,3	22,0	24,3	24,1	22,2	26,1
Starting current		A	1,00	1,00	1,00	1,00	1,00	1,00	1,00	1,00
External static pressure (Max)		Pa	80	80	80	80	80	80	80	80
Air flow		m <sup>3</sup> /min	627	627	627	627	627	627	836	627
Sound pressure	Normal mode (Cool / Heat)	dB(A)	65,5/68,0	64,0/64,0	66,0/68,5	65,0/65,0	67,5/70,5	66,5/68,5	63,0/63,0	68,0/70,5
	Silent mode 1 / 2 (Cool)	dB(A)	62,5/60,5	61,0/59,0	63,0/61,0	62,0/60,0	64,5/62,5	63,5/61,5	60,0/58,0	65,0/63,0
Sound power	Normal mode (Cool / Heat)	dB(A)	83,0/85,0	81,5/81,5	83,5/85,5	82,0/82,0	84,5/87,5	83,5/85,5	81,0/81,0	85,0/87,5
Dimension	H x W x D	mm	1660 x 2640 (+120) x 765	1660 x 2640 (+120) x 765	1660 x 2640 (+120) x 765	1660 x 2640 (+120) x 765	1660 x 2640 (+120) x 765	1660 x 2640 (+120) x 765	1660 x 3520 (+180) x 765	1660 x 2640 (+120) x 765
Net weight		kg	612	609	612	609	615	612	812	615
Piping diameter <sup>3)</sup>	Liquid	Inch (mm)	1/2(12,70)/ 5/8(15,88)	1/2(12,70)/ 5/8(15,88)	5/8(15,88)/ 3/4(19,05)	5/8(15,88)/ 3/4(19,05)	5/8(15,88)/ 3/4(19,05)	5/8(15,88)/ 3/4(19,05)	5/8(15,88)/ 3/4(19,05)	5/8(15,88)/ 3/4(19,05)
	Gas	Inch (mm)	1-1/8(28,58)/ 1-3/8(34,96)	1-1/8(28,58)/ 1-3/8(34,96)	1-3/8(34,96)/ 15/8(15,88)	1-3/8(34,96)/ 15/8(15,88)	1-3/8(34,96)/ 15/8(15,88)	1-3/8(34,96)/ 15/8(15,88)	1-3/8(34,96)/ 15/8(15,88)	1-3/8(34,96)/ 15/8(15,88)
	Balance	Inch (mm)	1/4(6,35)	1/4(6,35)	1/4(6,35)	1/4(6,35)	1/4(6,35)	1/4(6,35)	1/4(6,35)	1/4(6,35)
Refrigerant (R32) / CO <sub>2</sub> Eq.		kg / T	21,1/14,24	19,1/12,89	21,2/14,31	19,2/12,96	23,3/15,73	21,3/14,38	25,2/17,01	23,4/15,80
Maximum allowable indoor / outdoor capacity ratio <sup>4)</sup>		%	50 ~ 130(200)	50 ~ 130(200)	50 ~ 130(200)	50 ~ 130(200)	50 ~ 130(200)	50 ~ 130(200)	50 ~ 130(200)	50 ~ 130(200)
Operating range	Cool Min ~ Max	°C	-10 ~ +52	-10 ~ +52	-10 ~ +52	-10 ~ +52	-10 ~ +52	-10 ~ +52	-10 ~ +52	-10 ~ +52
	Heat Min ~ Max	°C	-25 ~ +24	-25 ~ +24	-25 ~ +24	-25 ~ +24	-25 ~ +24	-25 ~ +24	-25 ~ +24	-25 ~ +24

1) EER and COP calculation is based in accordance to EN 14511. 2) SEER / SCOP is calculated based on the seasonal space cooling / heating efficiency "η" values of the COMMISSION REGULATION (EU) 2016/2281. SEER, SCOP = (η + Correction) × PEF. 3) Piping diameter under 100 m for ultimate indoor unit / over 100 m for ultimate indoor unit (if the longest piping equivalent length exceeds 100 m, increase the sizes of the main tubes by 1 rank for gas tubes and liquid tubes). 4) If the following conditions are satisfied, the effective range is above 130% and below 200%: A. Obey the limited number of connectable indoor units. B. The lower limit of operating range for heating outdoor temperature is limited to -10 °C WB (standard -25 °C WB). C. Simultaneous operation is limited to less than 130% of connectable indoor units.

HP			34 HP	36 HP	36 HP	36 HP	38 HP	38 HP	40 HP	40 HP
Outdoor unit			U-8MZ1E8	U-12MZ1E8	U-8MZ1E8	U-8MZ1E8	U-8MZ1E8	U-8MZ1E8	U-8MZ1E8	U-10MZ1E8
			U-8MZ1E8	U-12MZ1E8	U-8MZ1E8	U-8MZ1E8	U-8MZ1E8	U-10MZ1E8	U-8MZ1E8	U-10MZ1E8
			U-8MZ1E8	U-12MZ1E8	U-10MZ1E8	U-8MZ1E8	U-8MZ1E8	U-10MZ1E8	U-10MZ1E8	U-10MZ1E8
			U-10MZ1E8		U-10MZ1E8	U-12MZ1E8	U-12MZ1E8	U-10MZ1E8	U-12MZ1E8	U-10MZ1E8
Power supply	Voltage	V	380-400-415	380-400-415	380-400-415	380-400-415	380-400-415	380-400-415	380-400-415	380-400-415
	Phase		Three phase	Three phase	Three phase	Three phase	Three phase	Three phase	Three phase	Three phase
	Frequency	Hz	50	50	50	50	50	50	50	50
Cooling capacity		kW	95,2	100,0	100,0	100,0	106,0	106,0	111,0	112,0
EER <sup>1)</sup>		W/W	3,30	3,00	3,30	3,10	3,20	3,40	3,10	3,50
<b>SEER<sup>2)</sup> / η<sub>s,c</sub></b>			<b>7,37/291,8%</b>	<b>7,37/292,0%</b>	<b>7,53/298,2%</b>	<b>7,25/287,0%</b>	<b>7,36/291,7%</b>	<b>7,66/303,4%</b>	<b>7,30/289,0%</b>	<b>7,82/310,1%</b>
Current	A		48,60-46,10-44,50	54,90-52,20-50,40	50,40-47,80-46,20	53,40-50,70-48,90	55,20-52,40-50,60	52,20-49,50-47,90	60,00-57,00-55,00	54,00-51,20-49,60
Input power	kW		28,4	33,3	29,6	31,5	32,7	30,8	35,8	32,0
Heating capacity	kW		106,0	112,0	113,0	112,0	119,0	119,0	125,0	126,0
COP <sup>1)</sup>	W/W		4,40	3,90	4,30	4,20	4,20	4,30	4,10	4,30
<b>SCOP<sup>2)</sup> / η<sub>s,h</sub></b>			<b>4,29/168,7%</b>	<b>4,33/170,3%</b>	<b>4,33/170,3%</b>	<b>4,32/170,1%</b>	<b>4,31/169,6%</b>	<b>4,36/171,4%</b>	<b>4,29/168,8%</b>	<b>4,38/172,2%</b>
Current	A		41,93-39,86-38,44	47,10-44,70-43,20	44,62-42,44-40,96	45,13-42,86-41,34	47,82-45,44-43,86	47,31-45,02-43,48	51,02-48,44-46,76	50,00-47,60-46,00
Input power	kW		24,0	28,2	25,8	26,1	27,8	27,6	29,9	29,3
Starting current	A		1,00	1,00	1,00	1,00	1,00	1,00	1,00	1,00
External static pressure (Max)	Pa		80	80	80	80	80	80	80	80
Air flow	m <sup>3</sup> /min		836	627	836	836	836	836	836	836
Sound pressure	Normal mode (Cool / Heat)	dB(A)	64,0/64,0	69,0/72,0	65,0/65,0	66,0/68,5	66,5/68,5	65,5/65,5	68,0/70,5	66,0/66,0
	Silent mode 1 / 2 (Cool)	dB(A)	61,0/59,0	66,0/64,0	62,0/60,0	63,0/61,0	63,5/61,5	62,5/60,5	65,0/63,0	63,0/61,0
Sound power	Normal mode (Cool / Heat)	dB(A)	82,0/82,0	86,0/89,0	82,5/82,5	83,5/85,5	84,0/86,0	83,0/83,0	85,0/87,5	83,0/83,0
Dimension	HxWxD	mm	1660x3520 (+180)x765	1660x2640 (+120)x765	1660x3520 (+180)x765	1660x3520 (+180)x765	1660x3520 (+180)x765	1660x3520 (+180)x765	1660x3520 (+180)x765	1660x3520 (+180)x765
Net weight	kg		812	618	812	815	815	812	818	812
Piping diameter <sup>3)</sup>	Liquid	Inch (mm)	5/8(15,88)/ 3/4(19,05)	5/8(15,88)/ 3/4(19,05)	5/8(15,88)/ 3/4(19,05)	5/8(15,88)/ 3/4(19,05)	5/8(15,88)/ 3/4(19,05)	5/8(15,88)/ 3/4(19,05)	5/8(15,88)/ 3/4(19,05)	5/8(15,88)/ 3/4(19,05)
	Gas	Inch (mm)	1-3/8(34,96)/ 15/8(15,88)	1-3/8(34,96)/ 15/8(15,88)	1-3/8(34,96)/ 15/8(15,88)	1-3/8(34,96)/ 15/8(15,88)	1-3/8(34,96)/ 15/8(15,88)	1-3/8(34,96)/ 15/8(15,88)	1-3/8(34,96)/ 15/8(15,88)	1-3/8(34,96)/ 15/8(15,88)
	Balance	Inch (mm)	1/4(6,35)	1/4(6,35)	1/4(6,35)	1/4(6,35)	1/4(6,35)	1/4(6,35)	1/4(6,35)	1/4(6,35)
Refrigerant (R32) / CO <sub>2</sub> Eq.	kg / T		25,3/17,08	25,5/17,21	25,4/17,15	27,4/18,50	27,5/18,56	25,5/17,21	29,6/19,98	25,6/17,28
Maximum allowable indoor / outdoor capacity ratio <sup>4)</sup>	%		50 ~ 130(200)	50 ~ 130(200)	50 ~ 130(200)	50 ~ 130(200)	50 ~ 130(200)	50 ~ 130(200)	50 ~ 130(200)	50 ~ 130(200)
Operating range	Cool Min ~ Max	°C	-10 ~ +52	-10 ~ +52	-10 ~ +52	-10 ~ +52	-10 ~ +52	-10 ~ +52	-10 ~ +52	-10 ~ +52
	Heat Min ~ Max	°C	-25 ~ +24	-25 ~ +24	-25 ~ +24	-25 ~ +24	-25 ~ +24	-25 ~ +24	-25 ~ +24	-25 ~ +24

HP			40 HP	42 HP	42 HP	44 HP	44 HP	46 HP	48 HP
Outdoor unit			U-8MZ1E8	U-8MZ1E8	U-10MZ1E8	U-8MZ1E8	U-10MZ1E8	U-10MZ1E8	U-12MZ1E8
			U-10MZ1E8	U-10MZ1E8	U-10MZ1E8	U-12MZ1E8	U-10MZ1E8	U-12MZ1E8	U-12MZ1E8
			U-10MZ1E8	U-12MZ1E8	U-10MZ1E8	U-12MZ1E8	U-12MZ1E8	U-12MZ1E8	U-12MZ1E8
			U-12MZ1E8	U-12MZ1E8	U-12MZ1E8	U-12MZ1E8	U-12MZ1E8	U-12MZ1E8	U-12MZ1E8
Power supply	Voltage	V	380-400-415	380-400-415	380-400-415	380-400-415	380-400-415	380-400-415	380-400-415
	Phase		Three phase	Three phase	Three phase	Three phase	Three phase	Three phase	Three phase
	Frequency	Hz	50	50	50	50	50	50	50
Cooling capacity		kW	111,0	117,0	117,0	122,0	123,0	128,0	134,0
EER <sup>1)</sup>		W/W	3,20	3,10	3,30	3,00	3,20	3,00	3,00
<b>SEER<sup>2)</sup> / η<sub>s,c</sub></b>			<b>7,53/298,2%</b>	<b>7,43/294,4%</b>	<b>7,65/303,2%</b>	<b>7,28/288,5%</b>	<b>7,56/299,4%</b>	<b>7,41/293,7%</b>	<b>7,37/292,1%</b>
Current	A		57,00-54,10-52,30	61,80-58,70-56,70	58,80-55,80-54,00	66,60-63,30-61,10	63,60-60,40-58,40	68,40-65,00-62,80	73,20-69,60-67,20
Input power	kW		33,9	37,0	35,1	40,1	38,2	41,3	44,4
Heating capacity	kW		125,0	131,0	132,0	137,0	138,0	144,0	150,0
COP <sup>1)</sup>	W/W		4,20	4,10	4,20	4,00	4,10	4,00	4,00
<b>SCOP<sup>2)</sup> / η<sub>s,h</sub></b>			<b>4,34/170,6%</b>	<b>4,35/171,0%</b>	<b>4,36/171,6%</b>	<b>4,33/170,3%</b>	<b>4,34/170,7%</b>	<b>4,35/171,2%</b>	<b>4,33/170,3%</b>
Current	A		50,51-48,02-46,38	53,71-51,02-49,28	53,20-50,60-48,90	56,91-54,02-52,18	56,40-53,60-51,80	59,60-56,60-54,70	62,80-59,60-57,60
Input power	kW		29,6	31,7	31,4	33,7	33,4	35,5	37,5
Starting current	A		1,00	1,00	1,00	1,00	1,00	1,00	1,00
External static pressure (Max)	Pa		80	80	80	80	80	80	80
Air flow	m <sup>3</sup> /min		836	836	836	836	836	836	836
Sound pressure	Normal mode (Cool / Heat)	dB(A)	67,0/69,0	68,5/71,0	67,5/69,0	69,0/72,0	68,5/71,0	69,5/72,0	70,0/73,0
	Silent mode 1 / 2 (Cool)	dB(A)	64,0/62,0	65,5/63,5	64,5/62,5	66,0/64,0	65,5/63,5	66,5/64,5	67,0/65,0
Sound power	Normal mode (Cool / Heat)	dB(A)	84,5/86,0	85,5/88,0	84,5/86,0	86,5/89,0	85,5/88,0	86,5/89,0	87,0/90,0
Dimension	HxWxD	mm	1660x3520 (+180)x765	1660x3520 (+180)x765	1660x3520 (+180)x765	1660x3520 (+180)x765	1660x3520 (+180)x765	1660x3520 (+180)x765	1660x3520 (+180)x765
Net weight	kg		815	818	815	821	818	821	824
Piping diameter <sup>3)</sup>	Liquid	Inch (mm)	5/8(15,88)/ 3/4(19,05)	5/8(15,88)/ 3/4(19,05)	5/8(15,88)/ 3/4(19,05)	5/8(15,88)/ 3/4(19,05)	5/8(15,88)/ 3/4(19,05)	5/8(15,88)/ 3/4(19,05)	5/8(15,88)/ 3/4(19,05)
	Gas	Inch (mm)	1-3/8(34,96)/ 15/8(15,88)	1-3/8(34,96)/ 15/8(15,88)	1-3/8(34,96)/ 15/8(15,88)	1-3/8(34,96)/ 15/8(15,88)	1-3/8(34,96)/ 15/8(15,88)	1-3/8(34,96)/ 15/8(15,88)	1-3/8(34,96)/ 15/8(15,88)
	Balance	Inch (mm)	1/4(6,35)	1/4(6,35)	1/4(6,35)	1/4(6,35)	1/4(6,35)	1/4(6,35)	1/4(6,35)
Refrigerant (R32) / CO <sub>2</sub> Eq.	kg / T		27,6/18,63	29,7/20,05	27,7/18,70	31,8/21,47	29,8/20,12	31,9/21,53	34,0/22,95
Maximum allowable indoor / outdoor capacity ratio <sup>4)</sup>	%		50 ~ 130(200)	50 ~ 130(200)	50 ~ 130(200)	50 ~ 130(200)	50 ~ 130(200)	50 ~ 130(200)	50 ~ 130(200)
Operating range	Cool Min ~ Max	°C	-10 ~ +52	-10 ~ +52	-10 ~ +52	-10 ~ +52	-10 ~ +52	-10 ~ +52	-10 ~ +52
	Heat Min ~ Max	°C	-25 ~ +24	-25 ~ +24	-25 ~ +24	-25 ~ +24	-25 ~ +24	-25 ~ +24	-25 ~ +24

1) EER and COP calculation is based in accordance to EN 14511. 2) SEER / SCOP is calculated based on the seasonal space cooling / heating efficiency "η" values of the COMMISSION REGULATION (EU) 2016/2281. SEER, SCOP = (η + Correction) × PEF. 3) Piping diameter under 100 m for ultimate indoor unit / over 100 m for ultimate indoor unit (if the longest piping equivalent length exceeds 100 m, increase the sizes of the main tubes by 1 rank for gas tubes and liquid tubes). 4) If the following conditions are satisfied, the effective range is above 130% and below 200%: A. Obey the limited number of connectable indoor units. B. The lower limit of operating range for heating outdoor temperature is limited to -10 °C WB (standard -25 °C WB). C. Simultaneous operation is limited to less than 130% of connectable indoor units.

# NEW 3-Pipe ECOi EX MF4 Series R32



Simultaneous heating and cooling VRF system.

Core features.

## Wide operating limits

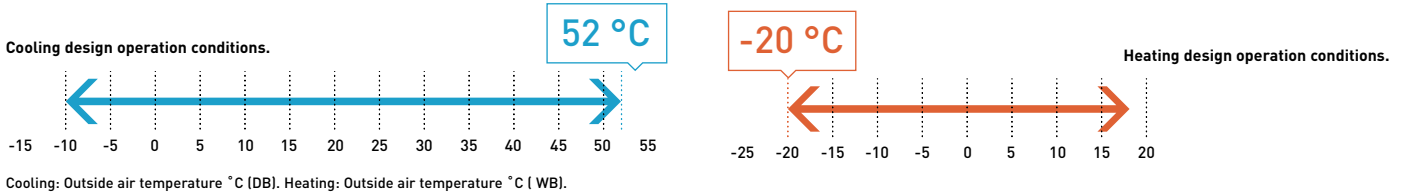

## Reduced refrigerant charge, lowering the requirements for additional safety measures and piping material choice

The new MF4 Series uses only 41%\* of the R32 refrigerant compared to the R410A equivalent system and supports imperial or metric piping installation.

\*Panasonic's internal research. 12 HP model with 80 m piping installation.

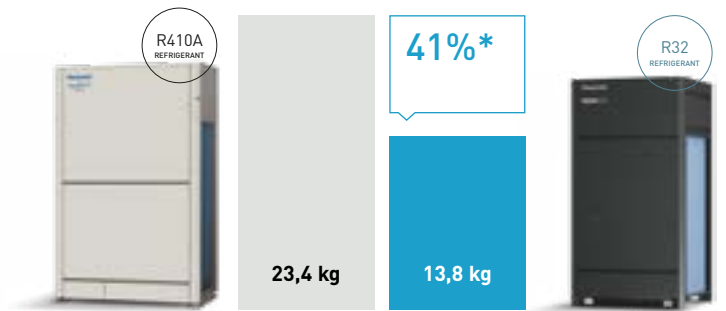

## Increased piping lengths and design flexibility

Adaptable to various building types and sizes. Actual piping length: 200 m. Maximum piping length: 500 m.

1) 40 m if the outdoor unit is below the indoor unit.

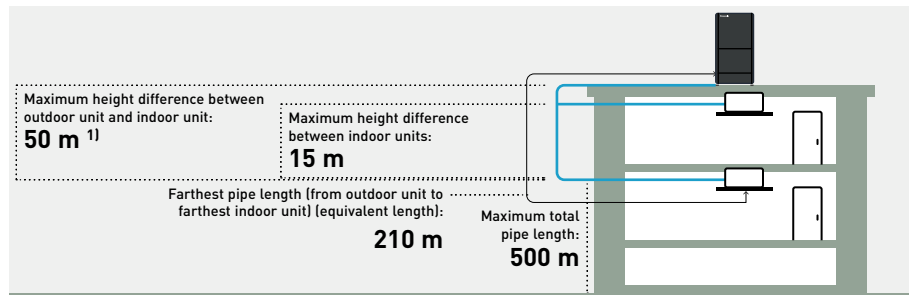

## Individual control of multiple indoor units with heat recovery boxes

· Cooling operation is possible with an outdoor temperature of -10 °C.

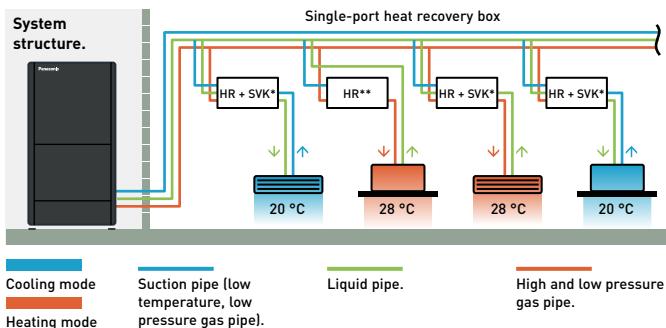

\*Heat recovery box with safety valve kit. \*\*Heat recovery box.

### Single-port heat recovery box: Wiring work.

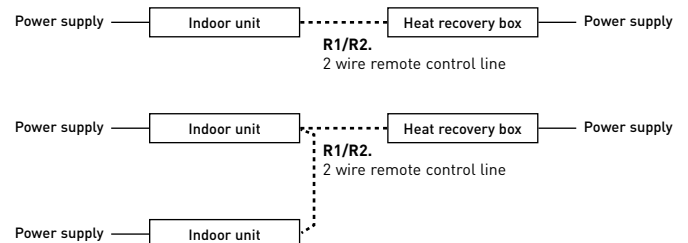

## Heat recovery box – Available with or without safety valve kit.

### 3-pipe heat recovery box with safety valve kit CZ-P1160SVHR.

- Single-port
- Fully compliant with IEC 60335-2-40 Ed.7
- Ideal for areas requiring R32 safety measures
- Suitable for hotel rooms, small offices



### 3-pipe heat recovery box CZ-P1160HR4.

- Single-port design
- Perfect for large spaces where no additional safety measures are required
- Cost-effective solution



NEW

**NEW! 3-Pipe ECOi EX MF4 Series - R32****Extreme efficiency, quality, compact.**

Advanced R32 refrigerant technology and optimised system design.

Wide operation range from -20 °C in heating to +52 °C in cooling.

HP			8 HP	10 HP	12 HP
Outdoor unit			U-8MF4E8	U-10MF4E8	U-12MF4E8
Power supply	Voltage	V	380-400-415	380-400-415	380-400-415
	Phase		Three phase	Three phase	Three phase
	Frequency	Hz	50	50	50
Cooling capacity		kW	22,4	28,0	33,5
EER <sup>1)</sup>		W/W	3,4	3,5	3,1
Current		A	11,2/10,7/10,3	13,4/12,7/12,2	17,8/16,9/16,3
Input power		kW	6,43	7,92	10,8
Heating capacity		kW	25,0	31,5	37,5
COP <sup>1)</sup>		W/W	4,3	4,2	3,9
Current		A	10,1/9,57/9,23	12,7/12,1/11,6	15,9/15,1/14,6
Input power		kW	5,70	7,49	9,61
Starting current		A	1,00	1,00	1,00
External static pressure (Max)		Pa	80	80	80
Air flow		m <sup>3</sup> /min	196	205	205
Sound pressure	Normal mode (Cool/Heat)	dB(A)	58,0/58,0	61,0/61,0	64,0/67,0
	Silent mode 1/2/3 (Cool)	dB(A)	55,0/53,0/50,0	58,0/56,0/50,0	61,0/59,0/50,0
Sound power	Normal mode (Cool/Heat)	dB(A)	76,0/76,0	78,0/78,0	81,0/84,0
Dimension	H x W x D	mm	1660x880x765	1660x880x765	1660x880x765
Net weight		kg	217	218	218
Piping diameter <sup>2)</sup>	Liquid	Inch (mm)	3/8(9,52)/1/2(12,70)	3/8(9,52)/1/2(12,70)	1/2(12,70)/5/8(15,88)
	Gas	Inch (mm)	5/8(15,88)/3/4(19,05)	5/8(15,88)/3/4(19,05)	3/4(19,05)/7/8(22,22)
	Suction	Inch (mm)	3/4(19,05)/7/8(22,22)	3/4(19,05)/7/8(22,22)	7/8(22,22)/1-1/8(28,58)
	Balance	Inch (mm)	1/4(6,35)	1/4(6,35)	1/4(6,35)
Refrigerant (R32)/CO <sub>2</sub> Eq		kg/T	8,10/5,47	8,80/5,94	9,20/6,21
Maximum allowable indoor/outdoor capacity ratio <sup>3)</sup>		%	50 ~ 150	50 ~ 150	50 ~ 150
Operating range	Cool Min ~ Max	°C	-10 ~ +52	-10 ~ +52	-10 ~ +52
	Heat Min ~ Max	°C	-20 ~ +18	-20 ~ +18	-20 ~ +18
	Simultaneous op.	°C	-10 ~ +24	-10 ~ +24	-10 ~ +24

**ErP data<sup>4)</sup>**

SEER <sup>5)</sup>	7,36	7,78	7,43
$\eta_{s,c}$	291,6%	308,3%	294,4%
SCOP <sup>5)</sup>	4,32	4,35	4,32
$\eta_{s,h}$	170,1%	171,0%	170,0%

1) EER and COP calculation is based in accordance to EN 14511. 2) Piping diameter under 100 m for ultimate indoor unit / over 100 m for ultimate indoor unit (if the longest piping equivalent length exceeds 100 m, increase the sizes of the main tubes by 1 rank for gas tubes and liquid tubes). 3) If the following conditions are satisfied, the effective range is above 130% and below 200%: A. Obey the limited number of connectable indoor units. B. The lower limit of operating range for heating outdoor temperature is limited to -10 °C WB (standard -25 °C WB). C. Simultaneous operation is limited to less than 130% of connectable indoor units. 4) SEER / SCOP and  $\eta_{s,c}$  /  $\eta_{s,h}$  are in accordance with ErP test data for U2 type 4 way 90x90 cassette indoor units. 5) SEER / SCOP is calculated based on the seasonal space cooling / heating efficiency "η" values of the COMMISSION REGULATION (EU) 2016/2281. SEER, SCOP = (η + Correction) × PEF.

\*Available in Summer 2026.

**Technical focus**

- 8-12 HP available in single systems, with scalability up to 36 HP in multi-combination systems
- Optional R32 refrigerant safety measures, including a heat recovery box with integrated safety valve kit, are available
- Compact outdoor unit with up to 43% smaller footprint and 49% reduced volume
- Uses only 41% of the R32 refrigerant charge required by an equivalent R410A system, reducing the need for additional safety measures
- Bluefin-coated heat exchanger as standard
- Extensive R32 product range, with all air-to-air indoor units equipped with nanoe™ X
- Wide range of connectivity options, including BMS integration for seamless system control and monitoring



## 3-Pipe ECOi EX MF4 Series combination from 16 to 36 HP - R32

HP		16 HP	18 HP	20 HP	20 HP	22 HP	24 HP	24 HP	26 HP
Outdoor unit		U-8MF4E8	U-8MF4E8	U-8MF4E8	U-10MF4E8	U-10MF4E8	U-12MF4E8	U-8MF4E8	U-8MF4E8
		U-8MF4E8	U-10MF4E8	U-12MF4E8	U-10MF4E8	U-12MF4E8	U-12MF4E8	U-8MF4E8	U-8MF4E8
Power supply	Voltage	V	380-400-415	380-400-415	380-400-415	380-400-415	380-400-415	380-400-415	380-400-415
	Phase		Three phase	Three phase	Three phase	Three phase	Three phase	Three phase	Three phase
	Frequency	Hz	50	50	50	50	50	50	50
Cooling capacity		kW	44,8	50,4	55,9	56,0	61,5	67,0	72,8
EER <sup>1)</sup>		W/W	3,4	3,5	3,2	3,5	3,2	3,1	3,4
SEER <sup>2)</sup> / $\eta_{s,c}$			<b>7,36-291,6%</b>	<b>7,58-300,4%</b>	<b>7,38-292,3%</b>	<b>7,78-308,3%</b>	<b>7,55-299,3%</b>	<b>7,38-292,5%</b>	<b>291,6-7,36%</b>
Current		A	11,2-10,7-10,3	13,4-12,7-12,2	17,8-16,9-16,3	13,4-12,7-12,2	17,8-16,9-16,3	17,8-16,9-16,3	11,2-10,7-10,3
Input power		kW	12,9	14,4	17,3	15,9	18,8	21,6	19,3
Heating capacity		kW	50,0	56,5	62,5	63,0	69,0	75,0	81,5
COP <sup>1)</sup>		W/W	4,3	4,2	4,0	4,2	4,0	3,8	4,3
SCOP <sup>2)</sup> / $\eta_{s,h}$			<b>4,32-170,0%</b>	<b>4,32-169,9%</b>	<b>4,30-169,3%</b>	<b>4,35-171,0%</b>	<b>4,30-169,2%</b>	<b>4,32-169,9%</b>	<b>4,32-170,0%</b>
Current		A	10,1-9,57-9,23	12,7-12,1-11,6	15,9-15,1-14,6	12,7-12,1-11,6	15,9-15,1-14,6	15,9-15,1-14,6	10,1-9,57-9,23
Input power		kW	11,4	13,2	15,4	15,0	17,1	19,3	17,1
Starting current		A	1,00	1,00	1,00	1,00	1,00	1,00	1,00
External static pressure (Max)		Pa	80	80	80	80	80	80	80
Air flow		m <sup>3</sup> /min	392	401	401	410	410	410	588
Sound pressure	Normal mode (Cool / Heat)	dB(A)	61,0/61,0	63,0/63,0	65,0/67,5	64,0/64,0	66,0/68,0	67,0/70,0	63,0/63,0
	Silent mode 1 / 2 (Cool)	dB(A)	58,0/56,0	60,0/58,0	62,0/60,0	61,0/59,0	63,0/61,0	64,0/62,0	60,0/58,0
Sound power	Normal mode (Cool / Heat)	dB(A)	79,0/79,0	80,5/80,5	82,5/85,0	81,0/81,0	83,0/85,0	84,0/87,0	81,0/81,0
Dimension	HxWxD	mm	1660x1760(+60)x765	1660x1760(+60)x765	1660x1760(+60)x765	1660x1760(+60)x765	1660x1760(+60)x765	1660x1760(+60)x765	1660x2640(+120)x765
Net weight		kg	434	435	435	436	436	436	651
Piping diameter <sup>3)</sup>	Liquid	Inch (mm)	1/2(12,70) / 5/8(15,88)	1/2(12,70) / 5/8(15,88)	1/2(12,70) / 5/8(15,88)	1/2(12,70) / 5/8(15,88)	1/2(12,70) / 5/8(15,88)	1/2(12,70) / 5/8(15,88)	1/2(12,70) / 5/8(15,88)
	Gas	Inch (mm)	3/4(19,05) / 7/8(22,22)	3/4(19,05) / 7/8(22,22)	7/8(22,22) / 1-1/8(28,58)	7/8(22,22) / 1-1/8(28,58)	7/8(22,22) / 1-1/8(28,58)	7/8(22,22) / 1-1/8(28,58)	7/8(22,22) / 1-1/8(28,58)
	Suction	Inch (mm)	7/8(22,22) / 1-1/8(28,58)	7/8(22,22) / 1-1/8(28,58)	1-1/8(28,58) / 1-3/8(34,96)	1-1/8(28,58) / 1-3/8(34,96)	1-1/8(28,58) / 1-3/8(34,96)	1-1/8(28,58) / 1-3/8(34,96)	1-1/8(28,58) / 1-3/8(34,96)
	Balance	Inch (mm)	1/4(6,35)	1/4(6,35)	1/4(6,35)	1/4(6,35)	1/4(6,35)	1/4(6,35)	1/4(6,35)
Refrigerant (R32) / CO <sub>2</sub> , Eq.		kg / T	16,2/10,94	16,9/11,41	17,3/11,68	17,6/11,88	18,0/12,15	18,4/12,42	24,3/16,40
Maximum allowable indoor / outdoor capacity ratio <sup>4)</sup>		%	50 ~ 150	50 ~ 150	50 ~ 150	50 ~ 150	50 ~ 150	50 ~ 150	50 ~ 150
Operating range	Cool Min ~ Max	°C	-10 ~ +52	-10 ~ +52	-10 ~ +52	-10 ~ +52	-10 ~ +52	-10 ~ +52	-10 ~ +52
	Heat Min ~ Max	°C	-20 ~ +18	-20 ~ +18	-20 ~ +18	-20 ~ +18	-20 ~ +18	-20 ~ +18	-20 ~ +18
	Simultaneous op.	°C	-10 ~ +24	-10 ~ +24	-10 ~ +24	-10 ~ +24	-10 ~ +24	-10 ~ +24	-10 ~ +24

1) EER and COP calculation is based in accordance to EN 14511. 2) SEER / SCOP is calculated based on the seasonal space cooling / heating efficiency "η" values of the COMMISSION REGULATION (EU) 2016/2281. SEER, SCOP = (η + Correction) × PEF. SEER / SCOP and  $\eta_{s,c}$  /  $\eta_{s,h}$  are in accordance with ErP test data for U2 type 4 way 90x90 cassette indoor units. 3) Piping diameter under 100 m for ultimate indoor unit / over 100 m for ultimate indoor unit (if the longest piping equivalent length exceeds 100 m, increase the sizes of the main tubes by 1 rank for gas tubes and liquid tubes). 4) If the following conditions are satisfied, the effective range is above 130% and below 200%: A. Obey the limited number of connectable indoor units. B. The lower limit of operating range for heating outdoor temperature is limited to -10 °C WB (standard -25 °C WB). C. Simultaneous operation is limited to less than 130% of connectable indoor units.

HP			28 HP	28 HP	30 HP	30 HP	32 HP	32 HP	34 HP	36 HP	
			U-8MF4E8	U-8MF4E8	U-8MF4E8	U-10MF4E8	U-8MF4E8	U-10MF4E8	U-10MF4E8	U-12MF4E8	U-12MF4E8
	Outdoor unit		U-8MF4E8	U-10MF4E8	U-10MF4E8	U-10MF4E8	U-12MF4E8	U-10MF4E8	U-12MF4E8	U-12MF4E8	U-12MF4E8
Power supply	Voltage	V	380-400-415	380-400-415	380-400-415	380-400-415	380-400-415	380-400-415	380-400-415	380-400-415	
	Phase		Three phase	Three phase	Three phase	Three phase	Three phase	Three phase	Three phase	Three phase	
	Frequency	Hz	50	50	50	50	50	50	50	50	
Cooling capacity		kW	78,3	78,4	83,9	84,0	89,4	89,5	95,0	100,0	
EER <sup>1)</sup>		W/W	3,3	3,5	3,3	3,5	3,1	3,3	3,2	3,0	
<b>SEER <sup>2)</sup> / <math>\eta_{s,c}</math></b>			<b>7,34-290,6%</b>	<b>7,59-300,9%</b>	<b>7,51-297,6%</b>	<b>7,73-306,2%</b>	<b>7,34-290,7%</b>	<b>7,61-301,5%</b>	<b>7,50-297,3%</b>	<b>7,39-292,8%</b>	
Current		A	17,8-16,9-16,3	13,4-12,7-12,2	17,8-16,9-16,3	13,4-12,7-12,2	17,8-16,9-16,3	17,8-16,9-16,3	17,8-16,9-16,3	17,8-16,9-16,3	
Input power		kW	23,7	22,3	25,2	23,8	28,1	26,7	29,6	32,4	
Heating capacity		kW	87,5	88,0	94,0	94,5	100,0	100,0	106,0	112,0	
COP <sup>1)</sup>		W/W	4,1	4,2	4,1	4,2	4,0	4,0	3,9	3,8	
<b>SCOP <sup>2)</sup> / <math>\eta_{s,h}</math></b>			<b>4,29-168,7%</b>	<b>4,32-170,0%</b>	<b>4,31-169,4%</b>	<b>4,35-171,0%</b>	<b>4,29-168,9%</b>	<b>4,33-170,3%</b>	<b>4,30-169,2%</b>	<b>4,32-170,0%</b>	
Current		A	15,9-15,1-14,6	12,7-12,1-11,6	15,9-15,1-14,6	12,7-12,1-11,6	15,9-15,1-14,6	15,9-15,1-14,6	15,9-15,1-14,6	15,9-15,1-14,6	
Input power		kW	21,1	20,7	22,8	22,5	25,0	24,6	26,8	28,9	
Starting current		A	1,00	1,00	1,00	1,00	1,00	1,00	1,00	1,00	
External static pressure (Max)		Pa	80	80	80	80	80	80	80	80	
Air flow		m <sup>3</sup> /min	597	606	606	615	606	615	615	615	
Sound pressure	Normal mode (Cool / Heat)	dB(A)	66,0/68,0	65,0/65,0	66,5/68,5	66,0/66,0	67,5/70,5	67,0/69,0	68,0/70,5	69,0/72,0	
	Silent mode 1 / 2 (Cool)	dB(A)	63,0/61,0	62,0/60,0	63,5/61,5	63,0/61,0	64,5/62,5	64,0/62,0	65,0/63,0	66,0/64,0	
Sound power	Normal mode (Cool / Heat)	dB(A)	83,5/85,5	82,5/82,5	83,5/85,5	83,0/83,0	85,0/87,5	84,0/86,0	85,0/87,5	86,0/89,0	
Dimension	HxWxD	mm	1660x2640 (+120)x765	1660x2640 (+120)x765	1660x2640 (+120)x765	1660x2640 (+120)x765	1660x2640 (+120)x765	1660x2640 (+120)x765	1660x2640 (+120)x765	1660x2640 (+120)x765	
Net weight		kg	652	653	653	654	653	654	654	654	
Piping diameter <sup>3)</sup>	Liquid	Inch (mm)	1/2(12,70) / 5/8(15,88)	1/2(12,70) / 5/8(15,88)	5/8(15,88) / 3/4(19,05)	5/8(15,88) / 3/4(19,05)	5/8(15,88) / 3/4(19,05)	5/8(15,88) / 3/4(19,05)	5/8(15,88) / 3/4(19,05)	5/8(15,88) / 3/4(19,05)	
	Gas	Inch (mm)	7/8(22,22) / 1-1/8(28,58)	7/8(22,22) / 1-1/8(28,58)	1-1/8(28,58) / 1-3/8(34,96)	1-1/8(28,58) / 1-3/8(34,96)	1-1/8(28,58) / 1-3/8(34,96)	1-1/8(28,58) / 1-3/8(34,96)	1-1/8(28,58) / 1-3/8(34,96)	1-1/8(28,58) / 1-3/8(34,96)	
	Suction	Inch (mm)	1-1/8(28,58) / 1-3/8(34,96)	1-1/8(28,58) / 1-3/8(34,96)	1-3/8(34,96) / 15/8(15,88)	1-3/8(34,96) / 15/8(15,88)	1-3/8(34,96) / 15/8(15,88)	1-3/8(34,96) / 15/8(15,88)	1-3/8(34,96) / 15/8(15,88)	1-3/8(34,96) / 15/8(15,88)	
	Balance	Inch (mm)	1/4(6,35)	1/4(6,35)	1/4(6,35)	1/4(6,35)	1/4(6,35)	1/4(6,35)	1/4(6,35)	1/4(6,35)	
Refrigerant (R32) / CO <sub>2</sub> Eq.		kg / T	25,4/17,15	25,7/17,35	26,1/17,62	26,4/17,82	26,5/17,89	26,8/18,09	27,2/18,36	27,6/18,63	
Maximum allowable indoor / outdoor capacity ratio <sup>4)</sup>		%	50 ~ 150	50 ~ 150	50 ~ 150	50 ~ 150	50 ~ 150	50 ~ 150	50 ~ 150	50 ~ 150	
Operating range	Cool Min ~ Max	°C	-10 ~ +52	-10 ~ +52	-10 ~ +52	-10 ~ +52	-10 ~ +52	-10 ~ +52	-10 ~ +52	-10 ~ +52	
	Heat Min ~ Max	°C	-20 ~ +18	-20 ~ +18	-20 ~ +18	-20 ~ +18	-20 ~ +18	-20 ~ +18	-20 ~ +18	-20 ~ +18	
	Simultaneous op.	°C	-10 ~ +24	-10 ~ +24	-10 ~ +24	-10 ~ +24	-10 ~ +24	-10 ~ +24	-10 ~ +24	-10 ~ +24	

1) EER and COP calculation is based in accordance to EN 14511. 2) SEER / SCOP is calculated based on the seasonal space cooling / heating efficiency "η" values of the COMMISSION REGULATION (EU) 2016/2281. SEER, SCOP = (η + Correction) × PEF. SEER / SCOP and  $\eta_{s,c}$  /  $\eta_{s,h}$  are in accordance with ErP test data for U2 type 4 way 90x90 cassette indoor units. 3) Piping diameter under 100 m for ultimate indoor unit / over 100 m for ultimate indoor unit (if the longest piping equivalent length exceeds 100 m, increase the sizes of the main tubes by 1 rank for gas tubes and liquid tubes). 4) If the following conditions are satisfied, the effective range is above 130% and below 200%: A. Obey the limited number of connectable indoor units. B. The lower limit of operating range for heating outdoor temperature is limited to -10 °C WB (standard -25 °C WB). C. Simultaneous operation is limited to less than 130% of connectable indoor units.

## 2-Pipe ECOi EX ME2 Series R410A







Two independently controlled Inverter compressors achieve high-efficiency. Redesigned components in the body provide performance improvement especially in the rated cooling condition and EER performance\*.

\*Applicable to ECOi EX outdoor units over 14 HP [2-compressor models].

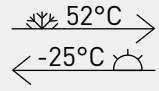
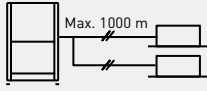

The ECOi EX can still operate at 100% capacity when the outside temperature is as high as 43 °C. This high power capability enables reliable operation even under extremely high temperature conditions.

<p><b>SEER SCOP</b></p> <p>7,56 <sup>1)</sup>    4,79 <sup>1)</sup></p>		
<p><b>High seasonal efficiency.</b></p>	<p><b>Saving installation space.</b></p>	<p><b>Silent operation.</b></p>
		
<p><b>Extended operation range.</b></p>	<p><b>Flexible piping installation.</b></p>	<p><b>Maximum indoor / outdoor capacity ratio 200%.</b></p>

**Extremely high capacity at -20 °C and unique heating capacity at -25 °C**

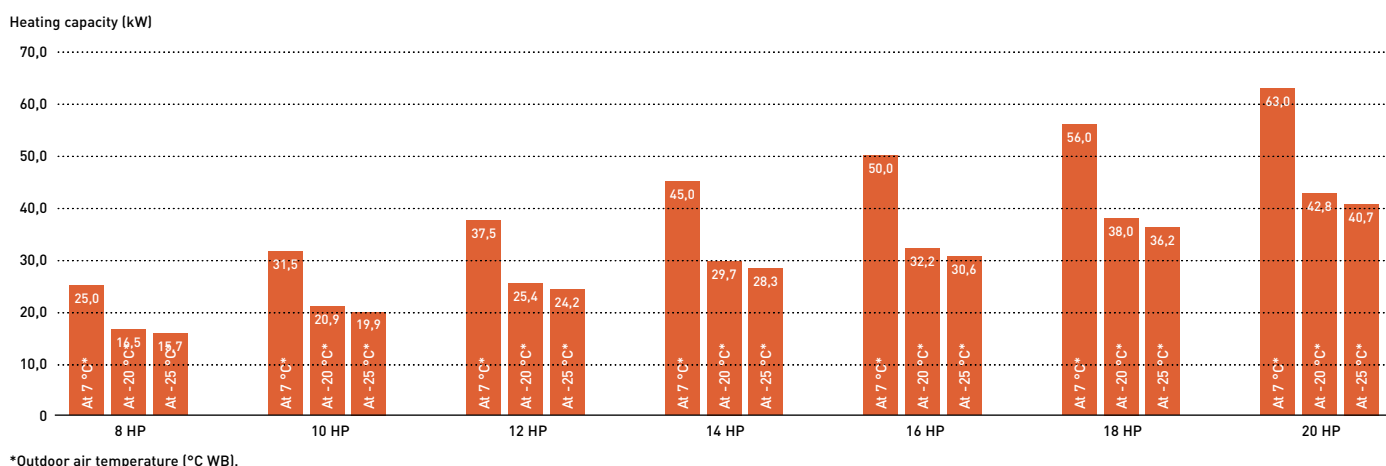

**High safety operation in case of breakdown!**

**Automatic Back-Up operation. Ensures heating and cooling.**

It is possible for the system to keep working, even if the compressors, fan motor and the temperature sensor are damaged (even when a compressor fails in single unit with 2 compressors inside).

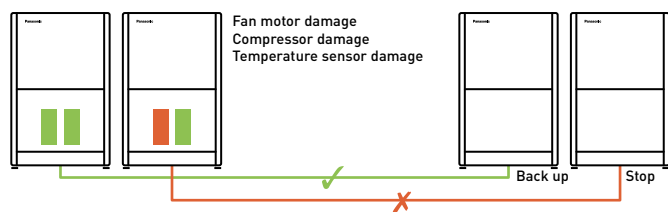

**The system maintains operation by bypassing up to 25% of units during power failure.**

In the event of a power failure, the system can be configured to maintain operation by ignoring up to 25% of active indoor units. Any stopped indoor units due to power failure will not affect continuous system operation.

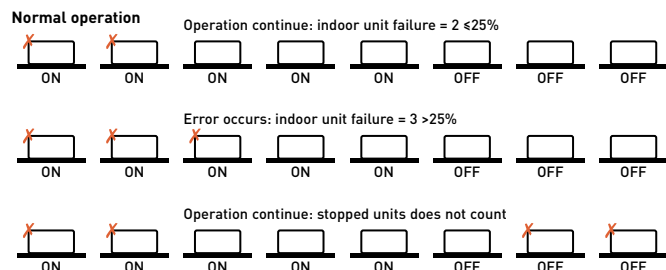

**Extended compressor life by uniform compressor operation time**

The total run-time of compressors are monitored by a built-in microcomputer, which ensures that operation times of all compressors within the same refrigerant circuit are balanced.

Compressors with histories showing shorter run times are selected first, ensuring equal wear and tear across all units and extending the working life of the system.

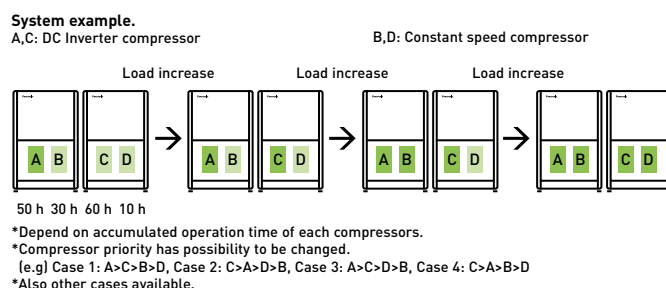

## 2-Pipe ECOi EX ME2 Series R410A piping design.

Select installation locations so that the lengths and sizes of refrigerant piping are within the allowable ranges shown in the figure below.

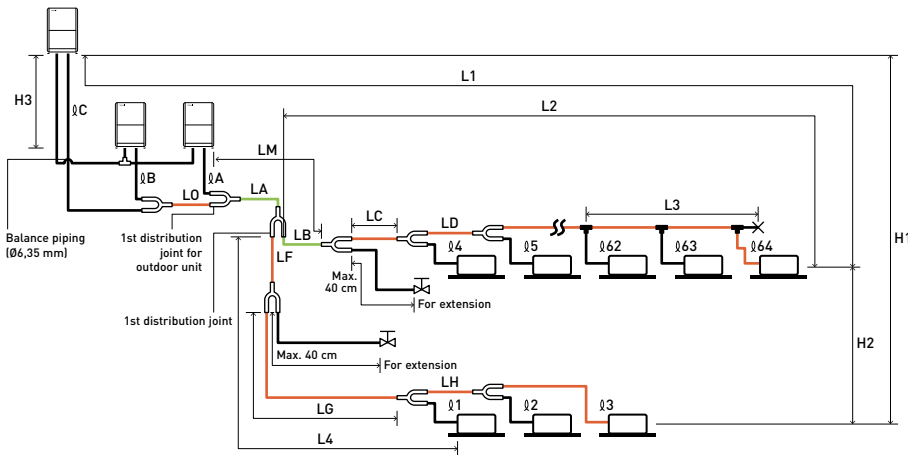

The outdoor connection main piping (LO portion) is determined by the total capacity of the outdoor units that are connected to the tube ends.

Note: Be sure to use special R410A distribution joints (CZ: optional parts) for outdoor unit connections and piping branches.

### R410A distribution joint.

- CZ-P680PH2BM (for outdoor unit)
- CZ-P1350PH2BM (for outdoor unit)
- CZ-P224BK2BM (for indoor unit)
- CZ-P680BK2BM (for indoor unit)
- CZ-P1350BK2BM (for indoor unit)

Main piping length (maximum piping size) LM= LA + LB ...

Main distribution tubes LC – LH are selected according to the capacity after the distribution joint.

Sizes of indoor unit connection piping  $\phi 1 - \phi 64$  are determined by the connection piping sizes on the indoor units.

Distribution joint (CZ: optional parts).

Ball valve (field supply).

T-joint (field supply).

Solidly welded shut (pinch weld).

### Ranges that apply to refrigerant piping lengths and to differences in installation heights

Items	Mark	Contents	Length (m)
Allowable piping length	L1	Maximum piping length	Actual length $\leq 200^{1)}$ Equivalent length $\leq 210^{1)}$
	$\Delta L (L2-L4)$	Difference between maximum length and minimum length from the 1st distribution joint	$\leq 50^{2)}$
	LM	Maximum length of main piping (at maximum size) *Even after 1st distribution joint, LM is allowed if at maximum piping length.	— <sup>3)</sup>
	$\phi 1, \phi 2 - \phi 64$	Maximum length of each distribution tube	$\leq 50^{4)}$
	$L1 + \phi 1 + \phi 2 - \phi 63 + \phi A + \phi B + LF + LG + LH$	Total maximum piping length including length of each distribution tube (only liquid piping)	$\leq 1000$
Allowable elevation difference	$\phi A, \phi B + LO, \phi C + LO$	Maximum piping length from outdoor's 1st distribution joint to each outdoor unit	$\leq 10$
	H1	When outdoor unit is installed higher than indoor unit	$\leq 50$
	H2	When outdoor unit is installed lower than indoor unit	$\leq 40$
	H3	Maximum difference between indoor units	$\leq 15$
Allowable length of joint piping	L3	T-joint piping (field-supply); Maximum piping length between the first T-joint and solidly welded-shut end point	$\leq 2$

L = Length, H = Height

1) If the longest piping length (L1) exceeds 90 m (equivalent length), increase the sizes of the main tubes (LM) by 1 rank for gas tubes and liquid tubes. Use a field supply reducer. Select the tube size from the table of main piping sizes (Table 3) and from the table of refrigerant piping sizes (Table 8). 2) When the piping length exceeds 40 m, increase a longer liquid or gas piping by 1 rank. Refer to the Technical Data for the details. 3) If the longest main piping length (LM) exceeds 50 m, increase the main piping size at the portion before 50 m by 1 rank for the gas tubes. Use a field supply reducer. Determine the length less than the limitation of allowable maximum piping length. For the portion that exceeds 50 m, set based on the main piping size (LA) listed in Table 3. 4) If any of the piping length exceeds 30 m, increase the size of the liquid and gas tubes by 1 rank. 5) If the total distribution piping length exceeds 500 m, maximum allowable elevation difference (H2) between the indoor units is calculated by the following formula. Make sure the indoor unit's actual elevation difference should fall within the figure calculated as follows. Unit of account (meter):  $15 \times [2 - \text{total piping length (m)} \div 500]$ .

\*The outdoor connection main piping (LO portion) is determined by the total capacity of the outdoor units that are connected to the tube ends. If the size of the existing piping is already larger than the standard piping size, it is not necessary to further increase the size. \*\*If the existing piping is used, and the amount of on-site refrigerant charge exceeds the value listed below, then change the size of the piping to reduce the amount of refrigerant. Total amount of refrigerant for the system with 1 outdoor unit: 50kg. Total amount of refrigerant for the system with 2 outdoor units: 80kg. Total amount of refrigerant for the system with 3 outdoor units or 4 outdoor units: 105 kg.

### Necessary amount of additional refrigerant charge per outdoor unit.

U-8ME2E8	U-10ME2E8	U-12ME2E8	U-14ME2E8	U-16ME2E8
5,5 kg	5,5 kg	7,0 kg	7,0 kg	7,0 kg

### System limitations.

Maximum number allowable connected outdoor units	4 <sup>1)</sup>
Maximum capacity allowable connected outdoor units	224 kW (80 HP)
Maximum connectable indoor units	64 <sup>2)</sup>
Maximum allowable indoor / outdoor capacity ratio	50-130% <sup>3)</sup>

- 1) Up to 4 units can be connected if the system has been extended.
- 2) In the case of 38 HP or smaller units, the number is limited by the total capacity of the connected indoor units.
- 3) If the following conditions are satisfied, the effective range is above 130% and below 200%.
  - A) Obey the limited number of connectable indoor units. B) The lower limit of operating range for heating outdoor temperature is limited to -10 °C WB (standard -25 °C WB). C) Simultaneous operation is limited to less than 130% of connectable indoor units.

### Additional refrigerant charge.

Liquid piping size (Inch (mm))	1/4 (6,35)	3/8 (9,52)	1/2 (12,70)	5/8 (15,88)	3/4 (19,05)	7/8 (22,22)	1 (25,40)
	Amount of refrigerant charge (g/m)	26	56	128	185	259	366

### Refrigerant piping (existing piping can be used).

Piping size (mm)				Material Temper - 1/2 H, H									
Material Temper - O													
$\phi 6,35$	t 0,8	$\phi 12,70$	t 0,8	$\phi 19,05$	t 1,2	$\phi 22,22$	t 1,0	$\phi 28,58$	t 1,0	$\phi 38,10$	over t 1,35	$\phi 44,45$	over t1,55
$\phi 9,52$	t 0,8	$\phi 15,88$	t 1,0			$\phi 25,40$	t 1,0	$\phi 31,75$	t 1,1	$\phi 41,28$	over t 1,45	$\phi 44,45$	over t1,55

\*When bending the tubes, use a bending radius that is at least 4 times the outer diameter of the tubes. In addition, take sufficient care to avoid crushing or damaging the tubes when bending them.

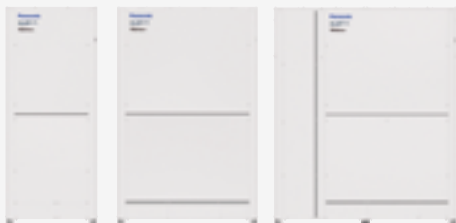

## 2-Pipe ECOi EX ME2 Series - R410A

A VRF system delivering energy saving performance, powerful operation, reliability and comfort, surpassing anything previously possible. It represents a true paradigm shift in air conditioning solutions.

VRF with outstanding energy saving performance and powerful operation SEER 7,56 (18 HP model).

HP			8 HP	10 HP	12 HP	14 HP	16 HP	18 HP	20 HP
Outdoor unit			U-8ME2E8	U-10ME2E8	U-12ME2E8	U-14ME2E8	U-16ME2E8	U-18ME2E8	U-20ME2E8
Power supply	Voltage	V	380-400-415	380-400-415	380-400-415	380-400-415	380-400-415	380-400-415	380-400-415
	Phase		Three phase	Three phase	Three phase	Three phase	Three phase	Three phase	Three phase
	Frequency	Hz	50	50	50	50	50	50	50
Cooling capacity		kW	22,4	28,0	33,5	40,0	45,0	50,0	56,0
EER <sup>1)</sup>		W/W	4,70	4,37	3,96	3,88	3,52	3,52	3,35
ESEER		W/W	9,33	8,67	7,94	7,73	7,19	6,95	6,18
Current		A	7,79-7,40-7,14	10,70-10,20-9,80	13,70-13,00-12,50	17,40-16,50-15,90	21,10-20,10-19,40	23,20-22,00-21,20	26,70-25,40-24,50
Input power		kW	4,77	6,41	8,47	10,30	12,80	14,20	16,70
Heating capacity		kW	25,0	31,5	37,5	45,0	50,0	56,0	63,0
COP <sup>1)</sup>		W/W	5,13	4,76	4,73	4,56	4,42	4,38	3,94
Current		A	7,96-7,56-7,29	11,10-10,50-10,10	12,90-12,30-11,80	16,60-15,80-15,20	18,90-17,90-17,30	21,10-20,10-19,40	25,90-24,60-23,70
Input power		kW	4,87	6,62	7,92	9,86	11,30	12,80	16,00
Starting current		A	1,00	1,00	1,00	2,00	2,00	2,00	2,00
External static pressure (Max)		Pa	80	80	80	80	80	80	80
Air flow		m <sup>3</sup> /min	224	224	232	232	232	405	405
Sound pressure	Normal mode	dB(A)	54	56	59	60	61	59	60
	Silent mode	dB(A)	51	53	56	57	58	56	57
Sound power	Normal mode	dB(A)	75	77	80	81	82	80	81
Dimension	HxWxD	mm	1842x770 x1000	1842x770 x1000	1842x1180 x1000	1842x1180 x1000	1842x1180 x1000	1842x1540 x1000	1842x1540 x1000
Net weight		kg	210	210	270	315	315	375	375
Piping diameter <sup>2)</sup>	Liquid	Inch (mm)	3/8(9,52)/ 1/2(12,70)	3/8(9,52)/ 1/2(12,70)	1/2(12,70)/ 5/8(15,88)	1/2(12,70)/ 5/8(15,88)	1/2(12,70)/ 5/8(15,88)	5/8(15,88)/ 3/4(19,05)	5/8(15,88)/ 3/4(19,05)
	Gas	Inch (mm)	3/4(19,05)/ 7/8(22,22)	7/8(22,22)/ 1(25,40)	1(25,40)/ 1-1/8(28,58)	1(25,40)/ 1-1/8(28,58)	1-1/8(28,58)/ 1-1/4(31,75)	1-1/8(28,58)/ 1-1/4(31,75)	1-1/8(28,58)/ 1-1/4(31,75)
	Balance	Inch (mm)	1/4(6,35)	1/4(6,35)	1/4(6,35)	1/4(6,35)	1/4(6,35)	1/4(6,35)	1/4(6,35)
Refrigerant (R410A) / CO <sub>2</sub> Eq		kg/T	5,60/11,6928	5,60/11,6928	8,30/17,3304	8,30/17,3304	8,30/17,3304	9,50/19,836	9,50/19,836
Maximum allowable indoor / outdoor capacity ratio <sup>3)</sup>		%	50 ~ 130 (200)	50 ~ 130 (200)	50 ~ 130 (200)	50 ~ 130 (200)	50 ~ 130 (200)	50 ~ 130 (200)	50 ~ 130 (200)
Operating range	Cool Min ~ Max	°C	-10 ~ +52	-10 ~ +52	-10 ~ +52	-10 ~ +52	-10 ~ +52	-10 ~ +52	-10 ~ +52
	Heat Min ~ Max	°C	-25 ~ +18	-25 ~ +18	-25 ~ +18	-25 ~ +18	-25 ~ +18	-25 ~ +18	-25 ~ +18

### ErP data <sup>4)</sup>

SEER <sup>5)</sup>	<b>7,43</b>	<b>6,96</b>	<b>6,74</b>	<b>7,23</b>	<b>6,43</b>	<b>7,56</b>	<b>7,03</b>
$\eta_{s,c}$	<b>294,3%</b>	<b>275,4%</b>	<b>266,6%</b>	<b>286,0%</b>	<b>254,3%</b>	<b>299,2%</b>	<b>278,2%</b>
SCOP <sup>5)</sup>	<b>4,79</b>	<b>4,27</b>	<b>4,72</b>	<b>4,28</b>	<b>4,05</b>	<b>4,29</b>	<b>4,09</b>
$\eta_{s,h}$	<b>188,4%</b>	<b>167,6%</b>	<b>185,8%</b>	<b>168,2%</b>	<b>159,0%</b>	<b>168,7%</b>	<b>160,4%</b>

1) EER and COP calculation is based in accordance to EN 14511. 2) Piping diameter under 90 m for ultimate indoor unit / over 90 m for ultimate indoor unit (if the longest piping equivalent length exceeds 90 m, increase the sizes of the main tubes by 1 rank for gas tubes and liquid tubes). 3) If the following conditions are satisfied, the effective range is above 130% and below 200%: A. Obey the limited number of connectable indoor units. B. The lower limit of operating range for heating outdoor temperature is limited to -10 °C WB (standard -25 °C WB). C. Simultaneous operation is limited to less than 130% of connectable indoor units. 4) SEER / SCOP and  $\eta_{s,c}$  /  $\eta_{s,h}$  are in accordance with ErP test data for F2 type variable static pressure hide-away indoor units. 5) SEER / SCOP is calculated based on the seasonal space cooling / heating efficiency "η" values of the COMMISSION REGULATION (EU) 2016/2281. SEER, SCOP = (η + Correction) × PEF.

## Technical focus

- Twin rotary Inverter compressor
- High performance at extreme conditions
- Outstanding efficiency and comfort
- Extraordinary partial load, SEER and SCOP
- SEER and SCOP following EN-14825
- Oil recovery intelligent control
- Top comfort
- Superior flexibility
- Bluefin full line up EX
- Extremely high capacity at -20 °C and unique heating capacity at -25 °C
- Smooth exhaust flow by bell-mouth

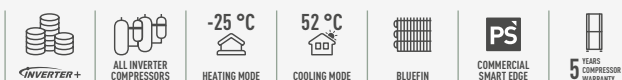

## 2-Pipe ECOi EX ME2 Series - R410A - High-efficiency model combination from 18 to 64 HP

HP			18 HP	20 HP	22 HP	24 HP	26 HP	28 HP
Outdoor unit			U-8ME2E8	U-10ME2E8	U-10ME2E8	U-12ME2E8	U-10ME2E8	U-12ME2E8
			U-10ME2E8	U-10ME2E8	U-12ME2E8	U-12ME2E8	U-16ME2E8	U-16ME2E8
Power supply	Voltage	V	380-400-415	380-400-415	380-400-415	380-400-415	380-400-415	380-400-415
	Phase		Three phase	Three phase	Three phase	Three phase	Three phase	Three phase
	Frequency	Hz	50	50	50	50	50	50
Cooling capacity	kW		50,0	56,0	61,5	68,0	73,0	78,5
EER <sup>1)</sup>	W/W		4,55	4,38	4,13	3,93	3,80	3,69
Current	A		18,20-17,30-16,60	21,40-20,30-19,60	24,30-23,10-22,30	28,00-26,60-25,60	31,70-30,10-29,00	34,80-33,10-31,90
Input power	kW		11,00	12,80	14,90	17,30	19,20	21,30
Heating capacity	kW		56,0	63,0	69,0	76,5	81,5	87,5
COP <sup>1)</sup>	W/W		4,96	4,77	4,76	4,69	4,55	4,56
Current	A		18,70-17,70-17,10	22,00-20,90-20,20	23,90-22,70-21,90	26,60-25,30-24,40	29,90-28,40-27,40	31,70-30,10-29,00
Input power	kW		11,30	13,20	14,50	16,30	17,90	19,20
Starting current	A		2,00	2,00	2,00	2,00	3,00	3,00
External static pressure (Max)	Pa		80	80	80	80	80	80
Air flow	m <sup>3</sup> /min		448	448	456	464	456	464
Sound pressure	Normal mode	dB(A)	58,5	59,0	61,0	62,0	62,5	63,5
	Silent mode	dB(A)	55,5	56,0	58,0	59,0	59,5	60,5
Sound power	Normal mode	dB(A)	79,5	80,0	82,0	83,0	83,5	84,5
Dimension / Net weight	HxWxD	mm / kg	1842 x 1600 x 1000 / 420	1842 x 1600 x 1000 / 420	1842 x 2010 x 1000 / 480	1842 x 2420 x 1000 / 540	1842 x 2010 x 1000 / 535	1842 x 2420 x 1000 / 585
	Liquid	Inch (mm)	5/8(15,88)/ 3/4(19,05)	5/8(15,88)/ 3/4(19,05)	5/8(15,88)/ 3/4(19,05)	5/8(15,88)/ 3/4(19,05)	3/4(19,05)/ 7/8(22,22)	3/4(19,05)/ 7/8(22,22)
Piping diameter <sup>2)</sup>	Gas	Inch (mm)	1-1/8(28,58)/ 1-1/4(31,75)	1-1/8(28,58)/ 1-1/4(31,75)	1-1/8(28,58)/ 1-1/4(31,75)	1-1/8(28,58)/ 1-1/4(31,75)	1-1/4(31,75)/ 1-1/2(38,10)	1-1/4(31,75)/ 1-1/2(38,10)
	Balance	Inch (mm)	1/4(6,35)	1/4(6,35)	1/4(6,35)	1/4(6,35)	1/4(6,35)	1/4(6,35)
Refrigerant (R410A) / CO <sub>2</sub> Eq.	kg / T		11,20/23,3856	11,20/23,3856	13,90/29,0232	16,60/34,6608	13,90/29,0232	16,60/34,6608
Maximum allowable indoor / outdoor capacity ratio <sup>3)</sup>	%		50 ~ 130(200)	50 ~ 130(200)	50 ~ 130(200)	50 ~ 130(200)	50 ~ 130(200)	50 ~ 130(200)
Operating range	Cool Min ~ Max	°C	-10 ~ +52	-10 ~ +52	-10 ~ +52	-10 ~ +52	-10 ~ +52	-10 ~ +52
	Heat Min ~ Max	°C	-25 ~ +18	-25 ~ +18	-25 ~ +18	-25 ~ +18	-25 ~ +18	-25 ~ +18

HP			30 HP	32 HP	34 HP	36 HP	38 HP	40 HP
Outdoor unit			U-14ME2E8	U-16ME2E8	U-10ME2E8	U-12ME2E8	U-10ME2E8	U-12ME2E8
			U-16ME2E8	U-16ME2E8	U-12ME2E8	U-12ME2E8	U-12ME2E8	U-16ME2E8
Power supply	Voltage	V	380-400-415	380-400-415	380-400-415	380-400-415	380-400-415	380-400-415
	Phase		Three phase	Three phase	Three phase	Three phase	Three phase	Three phase
	Frequency	Hz	50	50	50	50	50	50
Cooling capacity	kW		85,0	90,0	96,0	101,0	107,0	113,0
EER <sup>1)</sup>	W/W		3,68	3,52	4,05	3,95	3,84	3,75
Current	A		38,60-36,60-35,30	42,30-40,20-38,70	38,70-36,80-35,50	41,40-39,30-37,90	46,10-43,80-42,20	49,20-46,70-45,00
Input power	kW		23,10	25,60	23,70	25,60	27,90	30,10
Heating capacity	kW		95,0	100,0	108,0	113,0	119,0	127,0
COP <sup>1)</sup>	W/W		4,48	4,42	4,72	4,73	4,61	4,57
Current	A		35,40-33,60-32,40	37,70-35,80-34,60	37,80-35,90-34,60	39,00-37,10-35,80	42,60-40,50-39,00	45,90-43,60-42,00
Input power	kW		21,20	22,60	22,90	23,90	25,80	27,80
Starting current	A		4,00	4,00	3,00	3,00	4,00	4,00
External static pressure (Max)	Pa		80	80	80	80	80	80
Air flow	m <sup>3</sup> /min		464	464	688	696	688	696
Sound pressure	Normal mode	dB(A)	63,5	64,0	63,0	64,0	64,0	64,5
	Silent mode	dB(A)	60,5	61,0	60,0	61,0	61,0	61,5
Sound power	Normal mode	dB(A)	84,5	85,0	84,0	85,0	85,0	85,5
Dimension / Net weight	HxWxD	mm / kg	1842 x 2420 x 1000 / 630	1842 x 2420 x 1000 / 630	1842 x 3250 x 1000 / 750	1842 x 3660 x 1000 / 810	1842 x 3250 x 1000 / 795	1842 x 3660 x 1000 / 855
	Liquid	Inch (mm)	3/4(19,05)/ 7/8(22,22)	3/4(19,05)/ 7/8(22,22)	3/4(19,05)/ 7/8(22,22)	3/4(19,05)/ 7/8(22,22)	3/4(19,05)/ 7/8(22,22)	3/4(19,05)/ 7/8(22,22)
Piping diameter <sup>2)</sup>	Gas	Inch (mm)	1-1/4(31,75)/ 1-1/2(38,10)	1-1/4(31,75)/ 1-1/2(38,10)	1-1/4(31,75)/ 1-1/2(38,10)	1-1/2(38,10)/ 1-5/8(41,28)	1-1/2(38,10)/ 1-5/8(41,28)	1-1/2(38,10)/ 1-5/8(41,28)
	Balance	Inch (mm)	1/4(6,35)	1/4(6,35)	1/4(6,35)	1/4(6,35)	1/4(6,35)	1/4(6,35)
Refrigerant (R410A) / CO <sub>2</sub> Eq.	kg / T		16,60/34,6608	16,60/34,6608	22,20/46,3536	24,90/51,9912	22,20/46,3536	24,90/46,3536
Maximum allowable indoor / outdoor capacity ratio <sup>3)</sup>	%		50 ~ 130(200)	50 ~ 130(200)	50 ~ 130(200)	50 ~ 130(200)	50 ~ 130(200)	50 ~ 130(200)
Operating range	Cool Min ~ Max	°C	-10 ~ +52	-10 ~ +52	-10 ~ +52	-10 ~ +52	-10 ~ +52	-10 ~ +52
	Heat Min ~ Max	°C	-25 ~ +18	-25 ~ +18	-25 ~ +18	-25 ~ +18	-25 ~ +18	-25 ~ +18

Data is for reference. 1) EER and COP calculation is based in accordance to EN 14511. 2) Piping diameter under 90 m for ultimate indoor unit / over 90 m for ultimate indoor unit (if the longest piping equivalent length exceeds 90 m, increase the sizes of the main tubes by 1 rank for gas tubes and liquid tubes). 3) If the following conditions are satisfied, the effective range is above 130% and below 200%: A. Obey the limited number of connectable indoor units. B. The lower limit of operating range for heating outdoor temperature is limited to -10 °C WB (standard -25 °C WB). C. Simultaneous operation is limited to less than 130% of connectable indoor units.

HP			42 HP	44 HP	46 HP	48 HP	50 HP	52 HP
	Outdoor unit		U-10ME2E8	U-12ME2E8	U-14ME2E8	U-16ME2E8	U-10ME2E8	U-12ME2E8
			U-16ME2E8	U-16ME2E8	U-16ME2E8	U-16ME2E8	U-12ME2E8	U-12ME2E8
			U-16ME2E8	U-16ME2E8	U-16ME2E8	U-16ME2E8	U-12ME2E8	U-12ME2E8
Power supply	Voltage	V	380 - 400 - 415	380 - 400 - 415	380 - 400 - 415	380 - 400 - 415	380 - 400 - 415	380 - 400 - 415
	Phase		Three phase	Three phase	Three phase	Three phase	Three phase	Three phase
	Frequency	Hz	50	50	50	50	50	50
Cooling capacity		kW	118,0	124,0	130,0	135,0	140,0	145,0
EER <sup>1)</sup>		W/W	3,69	3,62	3,62	3,52	3,87	3,82
Current		A	52,80 - 50,20 - 48,40	56,00 - 53,20 - 51,30	59,90 - 56,90 - 54,90	63,40 - 60,20 - 58,10	59,10 - 56,20 - 54,20	62,10 - 59,00 - 56,80
Input power		kW	32,00	34,30	35,90	38,40	36,20	38,00
Heating capacity		kW	132,0	138,0	145,0	150,0	155,0	160,0
COP <sup>1)</sup>		W/W	4,49	4,50	4,46	4,42	4,65	4,66
Current		A	49,10 - 46,60 - 44,90	50,70 - 48,20 - 46,40	54,30 - 51,50 - 49,70	56,60 - 53,80 - 51,80	55,00 - 52,20 - 50,40	56,60 - 53,80 - 51,90
Input power		kW	29,40	30,70	32,50	33,90	33,30	34,30
Starting current		A	5,00	5,00	6,00	6,00	5,00	5,00
External static pressure (Max)		Pa	80	80	80	80	80	80
Air flow		m <sup>3</sup> /min	688	696	696	696	920	928
Sound pressure	Normal mode	dB(A)	65,0	65,5	65,5	66,0	65,5	66,0
	Silent mode	dB(A)	62,0	62,5	62,5	63,0	62,5	63,0
Sound power	Normal mode	dB(A)	86,0	86,5	86,5	87,0	86,5	87,0
Dimension / Net weight	H x W x D	mm / kg	1842 x 3250 x 1000 / 840	1842 x 3660 x 1000 / 900	1842 x 3660 x 1000 / 945	1842 x 3660 x 1000 / 945	1842 x 4490 x 1000 / 1065	1842 x 4900 x 1000 / 1125
	Liquid	Inch (mm)	3/4 (19,05) / 7/8 (22,22)	3/4 (19,05) / 7/8 (22,22)	3/4 (19,05) / 7/8 (22,22)	3/4 (19,05) / 7/8 (22,22)	3/4 (19,05) / 7/8 (22,22)	3/4 (19,05) / 7/8 (22,22)
Piping diameter <sup>2)</sup>	Gas	Inch (mm)	1-1/2 (38,10) / 1-5/8 (41,28)	1-1/2 (38,10) / 1-5/8 (41,28)	1-1/2 (38,10) / 1-5/8 (41,28)	1-1/2 (38,10) / 1-5/8 (41,28)	1-1/2 (38,10) / 1-5/8 (41,28)	1-1/2 (38,10) / 1-5/8 (41,28)
	Balance	Inch (mm)	1/4 (6,35)	1/4 (6,35)	1/4 (6,35)	1/4 (6,35)	1/4 (6,35)	1/4 (6,35)
Refrigerant (R410A) / CO <sub>2</sub> Eq.		kg / T	22,20 / 51,9912	24,90 / 51,9912	24,90 / 51,9912	24,90 / 51,9912	30,50 / 63,6840	33,20 / 69,3216
Maximum allowable indoor / outdoor capacity ratio <sup>3)</sup>		%	50 - 130 (200)	50 - 130 (200)	50 - 130 (200)	50 - 130 (200)	50 - 130 (200)	50 - 130 (200)
Operating range	Cool Min ~ Max	°C	-10 ~ +52	-10 ~ +52	-10 ~ +52	-10 ~ +52	-10 ~ +52	-10 ~ +52
	Heat Min ~ Max	°C	-25 ~ +18	-25 ~ +18	-25 ~ +18	-25 ~ +18	-25 ~ +18	-25 ~ +18

HP			54 HP	56 HP	58 HP	60 HP	62 HP	64 HP
	Outdoor unit		U-10ME2E8	U-12ME2E8	U-10ME2E8	U-12ME2E8	U-14ME2E8	U-16ME2E8
			U-12ME2E8	U-12ME2E8	U-16ME2E8	U-16ME2E8	U-16ME2E8	U-16ME2E8
			U-16ME2E8	U-16ME2E8	U-16ME2E8	U-16ME2E8	U-16ME2E8	U-16ME2E8
Power supply	Voltage	V	380 - 400 - 415	380 - 400 - 415	380 - 400 - 415	380 - 400 - 415	380 - 400 - 415	380 - 400 - 415
	Phase		Three phase	Three phase	Three phase	Three phase	Three phase	Three phase
	Frequency	Hz	50	50	50	50	50	50
Cooling capacity		kW	151,0	156,0	162,0	168,0	174,0	180,0
EER <sup>1)</sup>		W/W	3,75	3,71	3,65	3,60	3,60	3,52
Current		A	66,60 - 63,20 - 60,90	68,80 - 65,30 - 63,00	73,30 - 69,70 - 67,10	77,10 - 73,30 - 70,60	79,80 - 75,80 - 73,00	84,60 - 80,30 - 77,40
Input power		kW	40,30	42,10	44,40	46,70	48,30	51,20
Heating capacity		kW	169,0	175,0	182,0	189,0	195,0	201,0
COP <sup>1)</sup>		W/W	4,56	4,56	4,47	4,47	4,45	4,42
Current		A	61,90 - 58,80 - 56,70	63,40 - 60,20 - 58,10	68,00 - 64,60 - 62,20	70,60 - 67,10 - 64,70	73,10 - 69,50 - 67,00	76,00 - 72,20 - 69,60
Input power		kW	37,10	38,40	40,70	42,30	43,80	45,50
Starting current		A	6,00	6,00	7,00	7,00	8,00	8,00
External static pressure (Max)		Pa	80	80	80	80	80	80
Air flow		m <sup>3</sup> /min	920	928	920	928	928	928
Sound pressure	Normal mode	dB(A)	66,0	66,5	66,5	67,0	67,0	67,0
	Silent mode	dB(A)	63,0	63,5	63,5	64,0	64,0	64,0
Sound power	Normal mode	dB(A)	87,0	87,5	87,5	88,0	88,0	88,0
Dimension / Net weight	H x W x D	mm / kg	1842 x 4490 x 1000 / 1110	1842 x 4900 x 1000 / 1170	1842 x 4490 x 1000 / 1155	1842 x 4900 x 1000 / 1215	1842 x 4900 x 1000 / 1260	1842 x 4900 x 1000 / 1260
	Liquid	Inch (mm)	3/4 (19,05) / 7/8 (22,22)	3/4 (19,05) / 7/8 (22,22)	3/4 (19,05) / 7/8 (22,22)	3/4 (19,05) / 7/8 (22,22)	3/4 (19,05) / 7/8 (22,22)	3/4 (19,05) / 7/8 (22,22)
Piping diameter <sup>2)</sup>	Gas	Inch (mm)	1-1/2 (38,10) / 1-5/8 (41,28)	1-1/2 (38,10) / 1-5/8 (41,28)	1-1/2 (38,10) / 1-5/8 (41,28)	1-1/2 (38,10) / 1-5/8 (41,28)	1-5/8 (41,28) / 1-3/4 (44,45)	1-5/8 (41,28) / 1-3/4 (44,45)
	Balance	Inch (mm)	1/4 (6,35)	1/4 (6,35)	1/4 (6,35)	1/4 (6,35)	1/4 (6,35)	1/4 (6,35)
Refrigerant (R410A) / CO <sub>2</sub> Eq.		kg / T	30,50 / 63,6840	33,20 / 69,3216	30,50 / 63,6840	33,20 / 69,3216	33,20 / 69,3216	33,20 / 69,3216
Maximum allowable indoor / outdoor capacity ratio <sup>3)</sup>		%	50 - 130 (200)	50 - 130 (200)	50 - 130 (200)	50 - 130 (200)	50 - 130 (200)	50 - 130 (200)
Operating range	Cool Min ~ Max	°C	-10 ~ +52	-10 ~ +52	-10 ~ +52	-10 ~ +52	-10 ~ +52	-10 ~ +52
	Heat Min ~ Max	°C	-25 ~ +18	-25 ~ +18	-25 ~ +18	-25 ~ +18	-25 ~ +18	-25 ~ +18

Data is for reference. 1) EER and COP calculation is based in accordance to EN 14511. 2) Piping diameter under 90 m for ultimate indoor unit / over 90 m for ultimate indoor unit (if the longest piping equivalent length exceeds 90 m, increase the sizes of the main tubes by 1 rank for gas tubes and liquid tubes). 3) If the following conditions are satisfied, the effective range is above 130% and below 200%: A. Obey the limited number of connectable indoor units. B. The lower limit of operating range for heating outdoor temperature is limited to -10 °C WB [standard -25 °C WB]. C. Simultaneous operation is limited to less than 130% of connectable indoor units.

## 2-Pipe ECOi EX ME2 Series - R410A - Space saving model combination from 22 to 80 HP

HP			22 HP	24 HP	26 HP	28 HP	30 HP	32 HP	34 HP
	Outdoor unit		U-10ME2E8	U-12ME2E8	U-10ME2E8	U-12ME2E8	U-14ME2E8	U-16ME2E8	U-14ME2E8
			U-12ME2E8	U-12ME2E8	U-16ME2E8	U-16ME2E8	U-16ME2E8	U-16ME2E8	U-20ME2E8
Power supply	Voltage	V	380-400-415	380-400-415	380-400-415	380-400-415	380-400-415	380-400-415	380-400-415
	Phase		Three phase	Three phase	Three phase	Three phase	Three phase	Three phase	Three phase
	Frequency	Hz	50	50	50	50	50	50	50
Cooling capacity		kW	61,5	68,0	73,0	78,5	85,0	90,0	96,0
EER <sup>1)</sup>		W/W	4,13	3,93	3,80	3,69	3,68	3,52	3,56
<b>SEER <sup>2)</sup></b>			<b>6,90</b>	<b>6,86</b>	<b>6,62</b>	<b>6,60</b>	<b>6,88</b>	<b>6,55</b>	<b>7,21</b>
Current		A	24,30-23,10-22,30	28,00-26,60-25,60	31,70-30,10-29,00	34,80-33,10-31,90	38,60-36,60-35,30	42,30-40,20-38,70	44,10-41,90-40,40
Input power		kW	14,90	17,30	19,20	21,30	23,10	25,60	27,00
Heating capacity		kW	69,0	76,5	81,5	87,5	95,0	100,0	108,0
COP <sup>1)</sup>		W/W	4,76	4,69	4,55	4,56	4,48	4,42	4,17
<b>SCOP <sup>2)</sup></b>			<b>4,53</b>	<b>4,78</b>	<b>4,16</b>	<b>4,29</b>	<b>4,13</b>	<b>4,09</b>	<b>4,14</b>
Current		A	23,90-22,70-21,90	26,60-25,30-24,40	29,90-28,40-27,40	31,70-30,10-29,00	35,40-33,60-32,40	37,70-35,80-34,60	42,80-40,60-39,20
Input power		kW	14,50	16,30	17,90	19,20	21,20	22,60	25,90
Starting current		A	2,00	2,00	3,00	3,00	4,00	4,00	4,00
External static pressure (Max)		Pa	80	80	80	80	80	80	80
Air flow		m <sup>3</sup> /min	456	464	456	464	464	464	637
Sound pressure	Normal / Silent mode	dB(A)	61,0/58,0	62,0/59,0	62,5/59,5	63,5/60,5	63,5/60,5	64,0/61,0	63,0/60,0
Sound power	Normal mode	dB(A)	82,0	83,0	83,5	84,5	84,5	85,0	84,0
Dimension / Net weight	H x W x D	mm / kg	1842 x 2010 x 1000 / 480	1842 x 2420 x 1000 / 540	1842 x 2010 x 1000 / 525	1842 x 2420 x 1000 / 585	1842 x 2420 x 1000 / 630	1842 x 2420 x 1000 / 630	1842 x 2780 x 1000 / 690
Piping diameter <sup>3)</sup>	Liquid	Inch (mm)	5/8(15,88) / 3/4(19,05)	5/8(15,88) / 3/4(19,05)	3/4(19,05) / 7/8(22,22)	3/4(19,05) / 7/8(22,22)	3/4(19,05) / 7/8(22,22)	3/4(19,05) / 7/8(22,22)	3/4(19,05) / 7/8(22,22)
	Gas	Inch (mm)	1-1/8(28,58) / 1-1/4(31,75)	1-1/8(28,58) / 1-1/4(31,75)	1-1/4(31,75) / 1-1/2(38,10)	1-1/4(31,75) / 1-1/2(38,10)	1-1/4(31,75) / 1-1/2(38,10)	1-1/4(31,75) / 1-1/2(38,10)	1-1/4(31,75) / 1-1/2(38,10)
	Balance	Inch (mm)	1/4(6,35)	1/4(6,35)	1/4(6,35)	1/4(6,35)	1/4(6,35)	1/4(6,35)	1/4(6,35)
Refrigerant (R410A) / CO <sub>2</sub> Eq.		kg / T	13,90/23,3856	16,60/34,6608	13,90/29,0232	16,60/34,6608	16,60/34,6608	16,60/34,6608	17,80/37,1664
Maximum allowable indoor / outdoor capacity ratio <sup>4)</sup>		%	50 ~ 130(200)	50 ~ 130(200)	50 ~ 130(200)	50 ~ 130(200)	50 ~ 130(200)	50 ~ 130(200)	50 ~ 130(200)
Operating range	Cool Min - Max	°C	-10 ~ +52	-10 ~ +52	-10 ~ +52	-10 ~ +52	-10 ~ +52	-10 ~ +52	-10 ~ +52
	Heat Min - Max	°C	-25 ~ +18	-25 ~ +18	-25 ~ +18	-25 ~ +18	-25 ~ +18	-25 ~ +18	-25 ~ +18

HP			36 HP	38 HP	40 HP	42 HP	44 HP	46 HP	48 HP
	Outdoor unit		U-16ME2E8	U-18ME2E8	U-20ME2E8	U-10ME2E8	U-12ME2E8	U-14ME2E8	U-16ME2E8
			U-20ME2E8	U-20ME2E8	U-20ME2E8	U-16ME2E8	U-16ME2E8	U-16ME2E8	U-16ME2E8
Power supply	Voltage	V	380-400-415	380-400-415	380-400-415	380-400-415	380-400-415	380-400-415	380-400-415
	Phase		Three phase	Three phase	Three phase	Three phase	Three phase	Three phase	Three phase
	Frequency	Hz	50	50	50	50	50	50	50
Cooling capacity		kW	101,0	107,0	113,0	118,0	124,0	130,0	135,0
EER <sup>1)</sup>		W/W	3,42	3,42	3,34	3,69	3,62	3,62	3,52
<b>SEER <sup>2)</sup></b>			<b>6,86</b>	<b>7,32</b>	<b>7,16</b>	<b>6,57</b>	<b>6,60</b>	<b>6,70</b>	<b>6,55</b>
Current		A	47,70-45,30-43,70	50,60-48,10-46,30	54,10-51,40-49,50	52,80-50,20-48,40	56,00-53,20-51,30	59,90-56,90-54,90	63,40-60,20-58,10
Input power		kW	25,9	31,3	33,8	32,0	34,3	35,9	38,4
Heating capacity		kW	113,0	119,0	127,0	132,0	138,0	145,0	150,0
COP <sup>1)</sup>		W/W	4,14	4,13	3,92	4,49	4,50	4,46	4,42
<b>SCOP <sup>2)</sup></b>			<b>4,06</b>	<b>4,14</b>	<b>4,13</b>	<b>4,11</b>	<b>4,21</b>	<b>4,12</b>	<b>4,09</b>
Current		A	44,60-42,40-40,80	47,10-44,70-43,10	52,40-49,80-48,00	49,10-46,60-44,90	50,70-48,20-46,40	54,30-51,50-49,7	56,60-53,80-51,8
Input power		kW	27,30	28,80	32,40	29,40	30,70	32,50	33,90
Starting current		A	4,00	4,00	4,00	5,00	5,00	6,00	6,00
External static pressure (Max)		Pa	80	80	80	80	80	80	80
Air flow		m <sup>3</sup> /min	637	810	810	688	696	696	696
Sound pressure	Normal / Silent mode	dB(A)	63,5/60,5	62,5/59,5	63,0/60,0	65,0/62,0	65,5/62,5	65,5/62,5	66,0/63,0
Sound power	Normal mode	dB(A)	84,5	83,5	84,0	86,0	86,5	86,5	87,0
Dimension / Net weight	H x W x D	mm / kg	1842 x 2780 x 1000 / 690	1842 x 3140 x 1000 / 750	1842 x 3140 x 1000 / 750	1842 x 3250 x 1000 / 840	1842 x 3660 x 1000 / 900	1842 x 3660 x 1000 / 945	1842 x 3660 x 1000 / 945
Piping diameter <sup>3)</sup>	Liquid	Inch (mm)	3/4(19,05) / 7/8(22,22)	3/4(19,05) / 7/8(22,22)	3/4(19,05) / 7/8(22,22)	3/4(19,05) / 7/8(22,22)	3/4(19,05) / 7/8(22,22)	3/4(19,05) / 7/8(22,22)	3/4(19,05) / 7/8(22,22)
	Gas	Inch (mm)	1-1/2(38,10) / 1-5/8(41,28)	1-1/2(38,10) / 1-5/8(41,28)	1-1/2(38,10) / 1-5/8(41,28)	1-1/2(38,10) / 1-5/8(41,28)	1-1/2(38,10) / 1-5/8(41,28)	1-1/2(38,10) / 1-5/8(41,28)	1-1/2(38,10) / 1-5/8(41,28)
	Balance	Inch (mm)	1/4(6,35)	1/4(6,35)	1/4(6,35)	1/4(6,35)	1/4(6,35)	1/4(6,35)	1/4(6,35)
Refrigerant (R410A) / CO <sub>2</sub> Eq.		kg / T	17,80/37,1664	19,00/39,672	19,00/39,672	22,20/46,3536	24,90/51,9912	24,90/51,9912	24,90/51,9912
Maximum allowable indoor / outdoor capacity ratio <sup>4)</sup>		%	50 ~ 130(200)	50 ~ 130(200)	50 ~ 130(200)	50 ~ 130(200)	50 ~ 130(200)	50 ~ 130(200)	50 ~ 130(200)
Operating range	Cool Min - Max	°C	-10 ~ +52	-10 ~ +52	-10 ~ +52	-10 ~ +52	-10 ~ +52	-10 ~ +52	-10 ~ +52
	Heat Min - Max	°C	-25 ~ +18	-25 ~ +18	-25 ~ +18	-25 ~ +18	-25 ~ +18	-25 ~ +18	-25 ~ +18

1) EER and COP calculation is based in accordance to EN 14511. 2) SEER / SCOP is calculated based on the seasonal space cooling / heating efficiency "η" values of the COMMISSION REGULATION (EU) 2016/2281. SEER, SCOP = (η + Correction) × PEF. 3) Piping diameter under 90 m for ultimate indoor unit / over 90 m for ultimate outdoor unit (if the longest piping equivalent length exceeds 90 m, increase the sizes of the main tubes by 1 rank for gas tubes and liquid tubes). 4) If the following conditions are satisfied, the effective range is above 130% and below 200%: A. Obey the limited number of connectable indoor units. B. The lower limit of operating range for heating outdoor temperature is limited to -10 °C WB (standard -25 °C WB). C. Simultaneous operation is limited to less than 130% of connectable indoor units.

HP			50 HP	52 HP	54 HP	56 HP	58 HP	60 HP	62 HP	64 HP
Outdoor unit			U-14ME2E8	U-16ME2E8	U-14ME2E8	U-16ME2E8	U-18ME2E8	U-20ME2E8	U-14ME2E8	U-16ME2E8
			U-16ME2E8	U-16ME2E8	U-20ME2E8	U-20ME2E8	U-20ME2E8	U-20ME2E8	U-16ME2E8	U-16ME2E8
			U-20ME2E8	U-20ME2E8	U-20ME2E8	U-20ME2E8	U-20ME2E8	U-20ME2E8	U-16ME2E8	U-16ME2E8
Power supply	Voltage	V	380-400-415	380-400-415	380-400-415	380-400-415	380-400-415	380-400-415	380-400-415	380-400-415
	Phase		Three phase	Three phase	Three phase	Three phase	Three phase	Three phase	Three phase	Three phase
	Frequency	Hz	50	50	50	50	50	50	50	50
Cooling capacity	kW		140,0	145,0	151,0	156,0	162,0	168,0	174,0	180,0
EER <sup>1)</sup>	W/W		3,55	3,46	3,49	3,41	3,40	3,35	3,60	3,52
SEER <sup>2)</sup>			<b>6,96</b>	<b>6,72</b>	<b>7,16</b>	<b>6,92</b>	<b>7,30</b>	<b>7,16</b>	<b>6,68</b>	<b>6,55</b>
Current	A		64,40-61,10-58,90	68,50-65,00-62,70	70,00-66,50-64,10	74,00-70,30-67,80	76,90-73,10-70,40	80,10-76,10-73,40	79,80-75,80-73,00	84,60-80,30-77,40
Input power	kW		39,40	41,90	43,30	45,80	47,60	50,10	48,30	51,20
Heating capacity	kW		155,0	160,0	169,0	175,0	182,0	189,0	195,0	201,0
COP <sup>1)</sup>	W/W		4,29	4,27	4,11	4,08	4,06	3,94	4,45	4,42
SCOP <sup>2)</sup>			<b>4,08</b>	<b>4,05</b>	<b>4,13</b>	<b>4,07</b>	<b>4,13</b>	<b>4,13</b>	<b>4,11</b>	<b>4,09</b>
Current	A		59,60-56,60-54,60	61,90-58,80-56,70	67,10-63,80-61,50	70,10-66,60-64,20	73,20-69,50-67,00	77,60-73,70-71,00	73,10-69,50-67,00	76,00-72,20-69,60
Input power	kW		36,10	37,50	41,10	42,90	44,80	48,00	43,80	45,50
Starting current	A		6,00	6,00	6,00	6,00	6,00	6,00	8,00	8,00
External static pressure (Max)	Pa		80	80	80	80	80	80	80	80
Air flow	m <sup>3</sup> /min		869	869	1042	1042	1215	1215	928	928
Sound pressure	Normal / Silent mode	dB(A)	65,5/62,5	65,5/62,5	65,0/62,0	65,5/62,5	64,5/61,5	65,0/62,0	67,0/64,0	67,0/64,0
Sound power	Normal mode	dB(A)	86,5	86,5	86,0	86,5	85,5	86,0	88,0	88,0
Dimension / Net weight	H x W x D	mm / kg	1842 x 4020 x 1000/1005	1842 x 4020 x 1000/1005	1842 x 4380 x 1000/1065	1842 x 4380 x 1000/1065	1842 x 4740 x 1000/1125	1842 x 4740 x 1000/1125	1842 x 4900 x 1000/1260	1842 x 4900 x 1000/1260
	Piping diameter <sup>3)</sup>									
Piping diameter <sup>3)</sup>	Liquid	Inch (mm)	3/4(19,05)/7/8(22,22)	3/4(19,05)/7/8(22,22)	3/4(19,05)/7/8(22,22)	3/4(19,05)/7/8(22,22)	3/4(19,05)/7/8(22,22)	3/4(19,05)/7/8(22,22)	3/4(19,05)/7/8(22,22)	3/4(19,05)/7/8(22,22)
	Gas	Inch (mm)	1-1/2(38,10)/1-5/8(41,28)	1-1/2(38,10)/1-5/8(41,28)	1-1/2(38,10)/1-5/8(41,28)	1-1/2(38,10)/1-5/8(41,28)	1-1/2(38,10)/1-5/8(41,28)	1-1/2(38,10)/1-5/8(41,28)	1-5/8(41,28)/1-3/4(44,45)	1-5/8(41,28)/1-3/4(44,45)
	Balance	Inch (mm)	1/4(6,35)	1/4(6,35)	1/4(6,35)	1/4(6,35)	1/4(6,35)	1/4(6,35)	1/4(6,35)	1/4(6,35)
Refrigerant (R410A) / CO <sub>2</sub> Eq.	kg / T		26,10/54,4968	26,10/54,4968	27,30/57,0024	27,30/57,0024	28,50/59,508	28,50/59,508	33,20/69,3216	33,20/69,3216
Maximum allowable indoor / outdoor capacity ratio <sup>4)</sup>	%		50 ~ 130(200)	50 ~ 130(200)	50 ~ 130(200)	50 ~ 130(200)	50 ~ 130(200)	50 ~ 130(200)	50 ~ 130(200)	50 ~ 130(200)
Operating range	Cool Min ~ Max	°C	-10 ~ +52	-10 ~ +52	-10 ~ +52	-10 ~ +52	-10 ~ +52	-10 ~ +52	-10 ~ +52	-10 ~ +52
	Heat Min ~ Max	°C	-25 ~ +18	-25 ~ +18	-25 ~ +18	-25 ~ +18	-25 ~ +18	-25 ~ +18	-25 ~ +18	-25 ~ +18

HP			66 HP	68 HP	70 HP	72 HP	74 HP	76 HP	78 HP	80 HP
Outdoor unit			U-10ME2E8	U-12ME2E8	U-10ME2E8	U-16ME2E8	U-16ME2E8	U-16ME2E8	U-18ME2E8	U-20ME2E8
			U-16ME2E8	U-16ME2E8	U-20ME2E8	U-16ME2E8	U-18ME2E8	U-20ME2E8	U-20ME2E8	U-20ME2E8
			U-20ME2E8	U-20ME2E8	U-20ME2E8	U-20ME2E8	U-20ME2E8	U-20ME2E8	U-20ME2E8	U-20ME2E8
			U-20ME2E8	U-20ME2E8	U-20ME2E8	U-20ME2E8	U-20ME2E8	U-20ME2E8	U-20ME2E8	U-20ME2E8
Power supply	Voltage	V	380-400-415	380-400-415	380-400-415	380-400-415	380-400-415	380-400-415	380-400-415	380-400-415
	Phase		Three phase	Three phase	Three phase	Three phase	Three phase	Three phase	Three phase	Three phase
	Frequency	Hz	50	50	50	50	50	50	50	50
Cooling capacity	kW		185,0	190,0	196,0	202,0	208,0	213,0	219,0	224,0
EER <sup>1)</sup>	W/W		3,52	3,49	3,47	3,42	3,42	3,39	3,38	3,35
SEER <sup>2)</sup>			<b>6,92</b>	<b>6,91</b>	<b>7,09</b>	<b>6,86</b>	<b>7,03</b>	<b>7,01</b>	<b>7,18</b>	<b>7,16</b>
Current	A		85,00-80,80-77,80	88,10-83,70-80,70	91,30-86,80-83,60	95,40-90,60-87,30	98,30-93,40-90,00	101,70-96,60-93,10	103,50-98,30-94,70	106,80-101,50-97,80
Input power	kW		52,60	54,50	56,50	59,00	60,80	62,90	64,70	66,80
Heating capacity	kW		207,0	213,0	219,0	226,0	233,0	239,0	245,0	252,0
COP <sup>1)</sup>	W/W		4,16	4,18	4,05	4,14	4,12	4,03	4,03	3,94
SCOP <sup>2)</sup>			<b>4,11</b>	<b>4,17</b>	<b>4,13</b>	<b>4,06</b>	<b>4,12</b>	<b>4,07</b>	<b>4,13</b>	<b>4,13</b>
Current	A		81,20-77,10-74,30	83,30-79,20-76,30	87,40-83,10-80,10	89,20-84,70-81,70	92,30-87,70-84,50	96,90-92,00-88,70	98,30-93,40-90,00	103,40-98,30-94,70
Input power	kW		49,70	51,00	54,10	54,60	56,50	59,30	60,80	64,00
Starting current	A		7,00	7,00	7,00	8,00	8,00	8,00	8,00	8,00
External static pressure (Max)	Pa		80	80	80	80	80	80	80	80
Air flow	m <sup>3</sup> /min		1266	1274	1439	1274	1447	1447	1620	1620
Sound pressure	Normal / Silent mode	dB(A)	66,0/63,0	66,5/63,5	65,5/62,5	66,5/63,5	66,5/63,5	66,5/63,5	66,0/63,0	66,0/63,0
Sound power	Normal mode	dB(A)	87,0	87,5	86,5	87,5	87,5	87,5	87,0	87,0
Dimension / Net weight	H x W x D	mm / kg	1842 x 5210 x 1000/1275	1842 x 5620 x 1000/1335	1842 x 5570 x 1000/1335	1842 x 5620 x 1000/1380	1842 x 5980 x 1000/1440	1842 x 5980 x 1000/1440	1842 x 6340 x 1000/1500	1842 x 6340 x 1000/1500
	Piping diameter <sup>3)</sup>									
Piping diameter <sup>3)</sup>	Liquid	Inch (mm)	3/4(19,05)/7/8(22,22)	7/8(22,22)/1(25,04)	7/8(22,22)/1(25,04)	7/8(22,22)/1(25,04)	7/8(22,22)/1(25,04)	7/8(22,22)/1(25,04)	7/8(22,22)/1(25,04)	7/8(22,22)/1(25,04)
	Gas	Inch (mm)	1-5/8(41,28)/1-3/4(44,45)	1-5/8(41,28)/1-3/4(44,45)	1-5/8(41,28)/1-3/4(44,45)	1-3/4(44,45)/2(50,80)	1-3/4(44,45)/2(50,80)	1-3/4(44,45)/2(50,80)	1-3/4(44,45)/2(50,80)	1-3/4(44,45)/2(50,80)
	Balance	Inch (mm)	1/4(6,35)	1/4(6,35)	1/4(6,35)	1/4(6,35)	1/4(6,35)	1/4(6,35)	1/4(6,35)	1/4(6,35)
Refrigerant (R410A) / CO <sub>2</sub> Eq.	kg / T		32,90/68,6952	35,60/74,3328	34,10/19,836	35,80/68,6952	36,80/76,8384	36,80/76,8384	38,00/79,344	38,00/79,344
Maximum allowable indoor / outdoor capacity ratio <sup>4)</sup>	%		50 ~ 130(200)	50 ~ 130(200)	50 ~ 130(200)	50 ~ 130(200)	50 ~ 130(200)	50 ~ 130(200)	50 ~ 130(200)	50 ~ 130(200)
Operating range	Cool Min ~ Max	°C	-10 ~ +52	-10 ~ +52	-10 ~ +52	-10 ~ +52	-10 ~ +52	-10 ~ +52	-10 ~ +52	-10 ~ +52
	Heat Min ~ Max	°C	-25 ~ +18	-25 ~ +18	-25 ~ +18	-25 ~ +18	-25 ~ +18	-25 ~ +18	-25 ~ +18	-25 ~ +18

1) EER and COP calculation is based in accordance to EN 14511. 2) SEER / SCOP is calculated based on the seasonal space cooling / heating efficiency "η" values of the COMMISSION REGULATION (EU) 2016/2281. SEER, SCOP = (η + Correction) × PEF. 3) Piping diameter under 90 m for ultimate indoor unit / over 90 m for ultimate indoor unit (if the longest piping equivalent length exceeds 90 m, increase the sizes of the main tubes by 1 rank for gas tubes and liquid tubes). 4) If the following conditions are satisfied, the effective range is above 130% and below 200%: A. Obey the limited number of connectable indoor units. B. The lower limit of operating range for heating outdoor temperature is limited to -10 °C WB (standard -25 °C WB). C. Simultaneous operation is limited to less than 130% of connectable indoor units.

Rating conditions: Cooling indoor 27 °C DB / 19 °C WB. Cooling outdoor 35 °C DB / 24 °C WB. Heating indoor 20 °C DB. Heating outdoor 7 °C DB / 6 °C WB. (DB: Dry Bulb, WB: Wet Bulb). Specifications subject to change without notice. For detailed information about ErP / Energy Labelling, please visit our websites www.aircon.panasonic.eu or www.ptc.panasonic.eu.

# 3-Pipe ECOi EX MF3 Series R410A



## Simultaneous heating and cooling VRF system.

The Panasonic 3-Pipe ECOi EX MF3 Series offers the best solution for the most discerning customers and demanding installations.

### Simultaneous heating and cooling VRF System

The Panasonic 3-Pipe ECOi EX MF3 Series offers the ideal solution to meet customer's demands.

#### Upgraded energy efficiency utilized ECOi EX technology.

- SEER / SCOP improved in full capacities from 8 to 16 HP
- SEER / SCOP follows LOT21 (January 2018)
- Eurovent certified EER / COP

#### Design flexibility.

- High reliability even under extreme temperature conditions
- Connection of up to 52 indoor units
- Slim heat recovery box with just 200 mm height
- Farthest piping length between indoor and outdoor units: 200 m

#### Excellent seasonal energy saving.

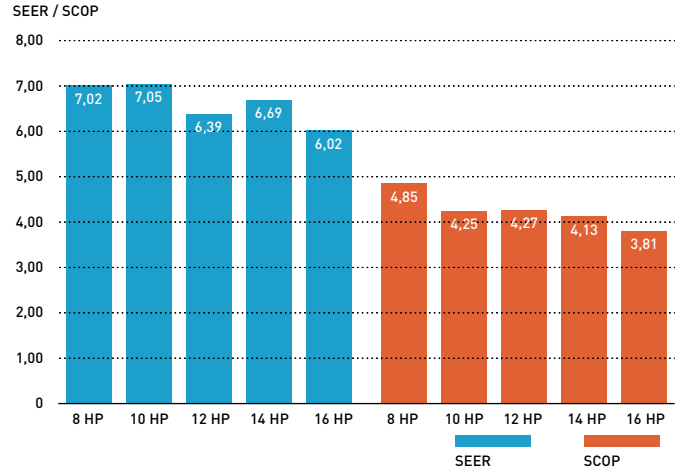

### Extended design operation conditions

Cooling design operation conditions: The cooling operating range has been extended to -10 °C ~ 52 °C by changing the outdoor fan to an Inverter type.

Heating design operation conditions: Stable heating operation even with an outside air temperature of -20 °C. The heating operating range has been extended to -20 °C by use of a compressor with a high-pressure vessel.

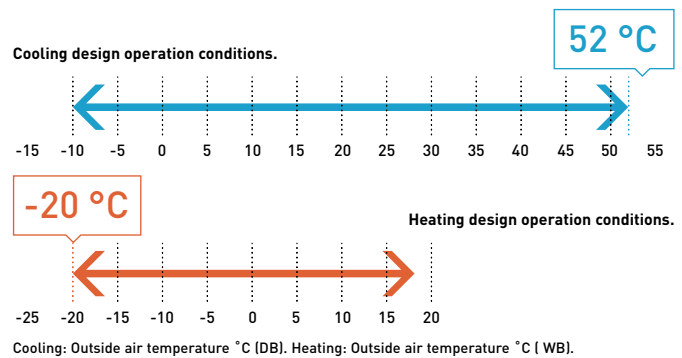

### Wide temperature setting range

Wired remote controller heating temperature setting range is 16 to 30 °C as standard.

### Increased maximum number of connectable indoor units

Maximum 48 HP with 52 indoor units can be set up according to user needs. Connectable indoor / outdoor unit capacity ratio up to 150%.

System ( HP)	8	10	12	14	16	18	20	22	24	26	28	30	32	34	36	38	40	42	44	46	48
Connectable indoor units*: 150%	19	24	29	34	39	43	48	52					52								

\*Depending on indoor units types. Please check service manuals.

### Power suppression control for energy saving (demand control) <sup>1)</sup>

The 3-Pipe ECOi EX MF3 Series has a built-in demand function which uses the Inverter characteristics. With this demand function, the power consumption can be set in three steps, and operation <sup>2)</sup> at optimum performance is performed according to the setting and the power consumption. This function is useful to reduce the annual power consumption and to save electricity costs while maintaining comfort.

1) An outdoor Seri-Para I/O unit is required for demand input.

2) Setting is possible as 0% or in the range from 40 to 100% (in steps of 5%). At the time of shipping, setting has been done to the three steps of 0%, 70%, and 100%.

# Slim 3-Pipe control box kit / Multiple connection type

Heat recovery Box to connect multiple indoor units with just one box, 4, 6 and up to 8 indoor units or groups.

The height is only 200 mm, which is especially advantageous in hotel applications, where space for connecting several boxes is limited.

## Individual control of multiple indoor units with solenoid valve kits.

- Any design and layout can be used in a single system.
- Cooling operation is possible with an outdoor temperature of -10 °C.

System structure.

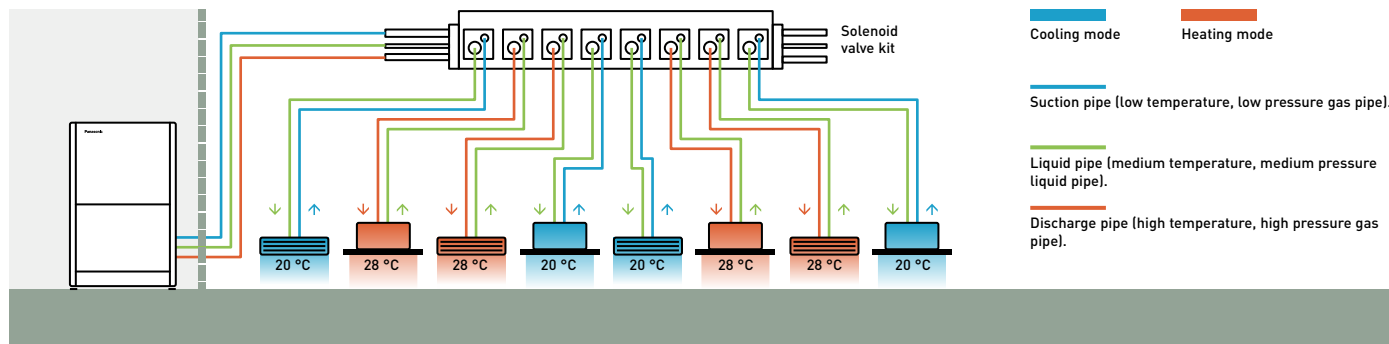

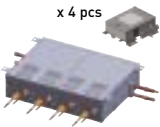
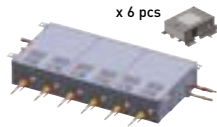
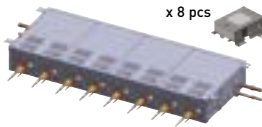
				
	1 port	4 port	6 port	8 port
56 type	CZ-P56HR3	CZ-P456HR3	CZ-P656HR3	CZ-P856HR3
160 type	CZ-P160HR3	CZ-P4160HR3	—	—

## Solenoid valve kit / wiring work

### Single connection type.

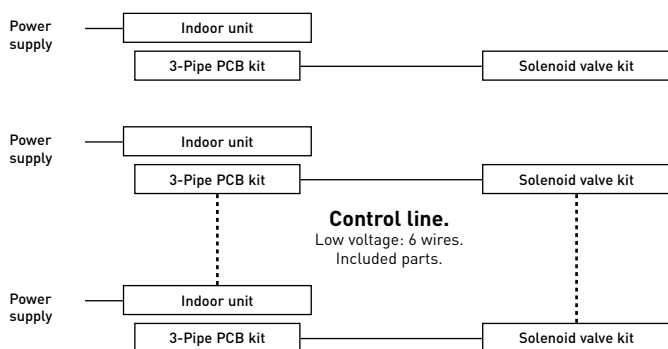

### Multiple connection type.

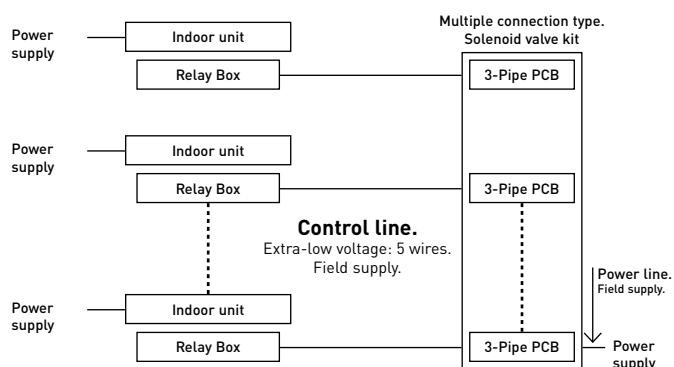

# 3-Pipe ECOi EX MF3 Series R410A superior flexibility

## Increased piping lengths and design flexibility

Adaptable to various building types and sizes. Actual piping length: 200 m. Maximum piping length: 500 m.

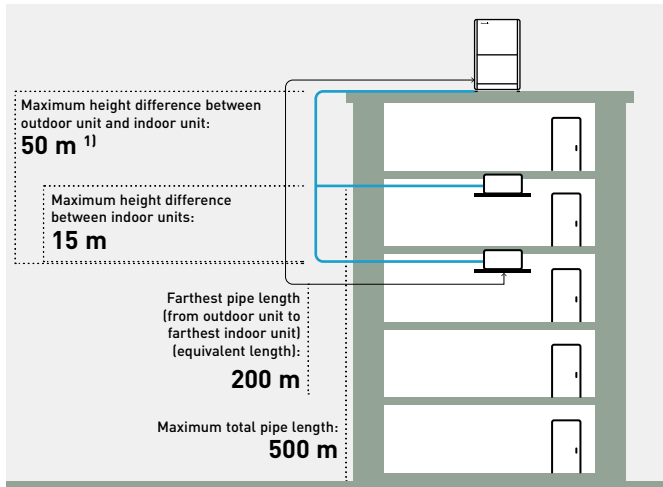

1) 40 m if the outdoor unit is below the indoor unit.

## Up to 40 m piping after first branch

Up to 52 units can be connected to one system. Flexible piping layout makes it easier to design systems for locations such as train stations, airports, schools and hospitals.

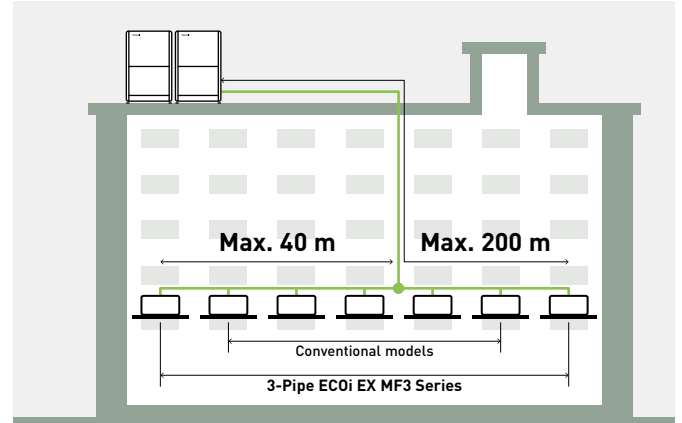

## Excellent cost saving and smaller piping size

By using R410A with low pressure loss, pipe sizes for discharge, suction and liquid are all reduced. This makes it possible to aim for reduced piping space, improved workability at the site, and reduction of the piping material costs.

8 HP

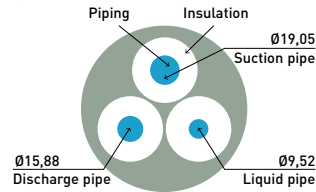

10 HP

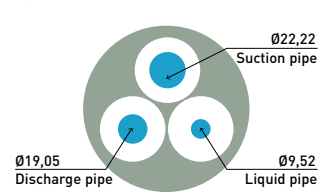

## High external static pressure on condensers

With an efficient fan shape, fan guard, motor, and casing, the models can be custom-installed on-site to provide up to 80 Pa of external static pressure.



Fan.

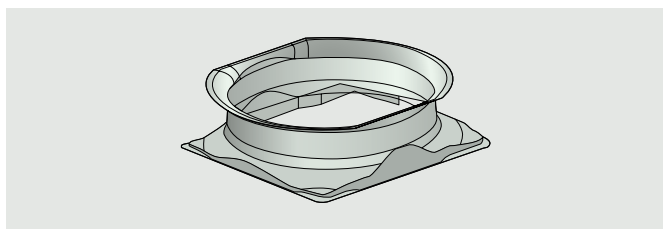

Bell-mouth casing.

An air discharge duct prevents air flow short-circuiting, allowing outdoor units to be installed on every floor of a building.

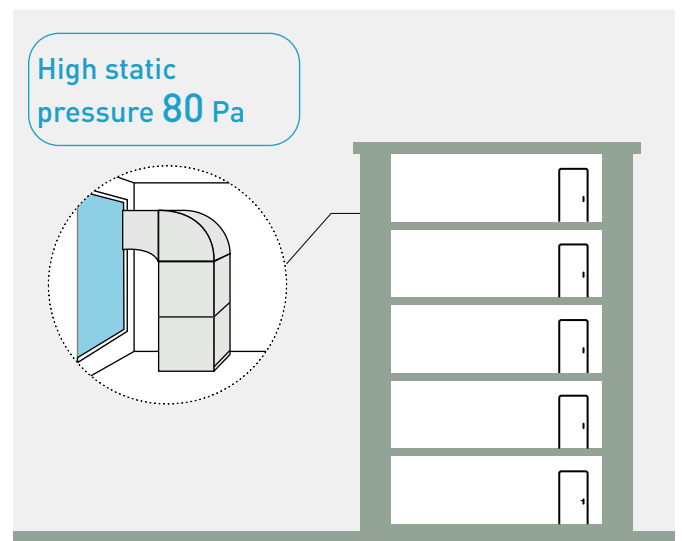

### 3-Pipe ECOi EX MF3 Series R410A piping design.

Select installation locations so that the lengths and sizes of refrigerant piping are within the allowable ranges shown in the figure below.

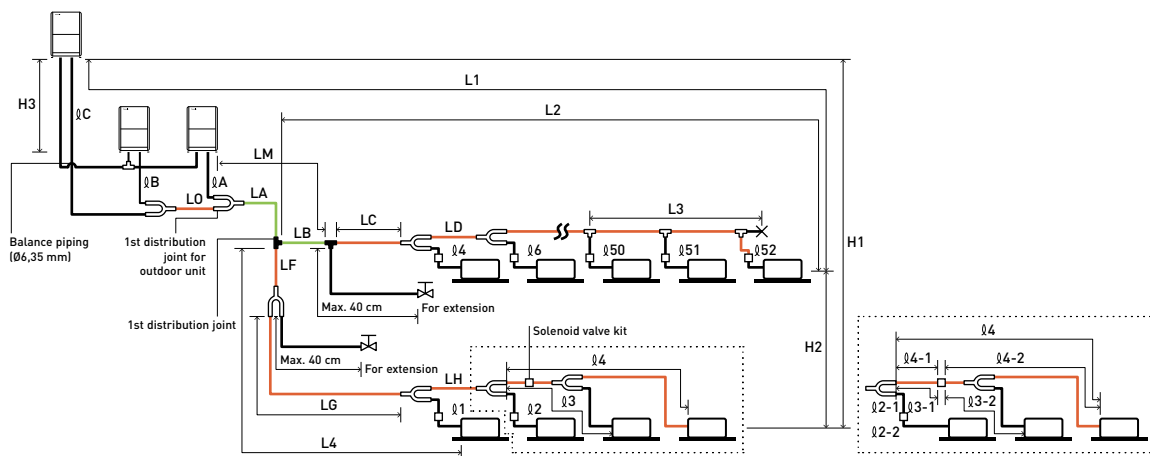

The outdoor connection main piping (LO portion) is determined by the total capacity of the outdoor units that are connected to the tube ends.  
 Note: Be sure to use special R410A distribution joints (CZ: optional parts) for outdoor unit connections and piping branches.

**R410A distribution joint.**  
 CZ-P680PJ2BM (for outdoor unit)  
 CZ-P1350PJ2BM (for outdoor unit)  
 CZ-P224BH2BM (for indoor unit)  
 CZ-P680BH2BM (for indoor unit)  
 CZ-P1350BH2BM (for indoor unit)

Main piping length (maximum piping size)  $LM = LA + LB \dots$

Main distribution tubes LC - LH are selected according to the capacity after the distribution joint.

Sizes of indoor unit connection piping  $\phi 1 - \phi 52$  are determined by the connection piping sizes on the indoor units.

Distribution joint (CZ: optional parts).

Ball valve (field supply).

T-joint (field supply).

Solidly welded shut (pinch weld).

#### Ranges that apply to refrigerant piping lengths and to differences in installation heights

Items	Mark	Contents	Length (m)
Allowable piping length	L1	Maximum piping length	Actual length $\leq 200^{1)}$ Equivalent length $\leq 210^{1)}$
	$\Delta L$ (L2-L4)	Difference between maximum length and minimum length from the 1st distribution joint	$\leq 50^{2)}$
	LM	Maximum length of main piping (at maximum size) *Even after 1st distribution joint, LM is allowed if at maximum piping length.	$\leq 50^{3)}$
	$\phi 1, \phi 2 - \phi 52$	Maximum length of each distribution tube	$\leq 50^{4)}$
	$L1 + \phi 1 + \phi 2 - \phi 51 + \phi A + \phi B + LF + LG + LH$	Total maximum piping length including length of each distribution tube (only liquid piping)	$\leq 500$
	$\phi A, \phi B + LO, \phi C + LO$	Maximum piping length from outdoor's 1st distribution joint to each outdoor unit	$\leq 10$
Allowable elevation difference	H1	When outdoor unit is installed higher than indoor unit	$\leq 50$
	H2	When outdoor unit is installed lower than indoor unit	$\leq 40$
	H3	Maximum difference between indoor units	$\leq 15^{5)}$
Allowable length of joint piping	L3	T-joint piping (field-supply); Maximum piping length between the first T-joint and solidly welded-shut end point	$\leq 2$

L = Length, H = Height

1) If the longest piping length (L1) exceeds 90 m (equivalent length), increase the sizes of the main pipes (LM) by 1 rank for suction pipes, discharge pipes and liquid pipes. Use a field supply reducer. Select the pipe size from the table of main piping sizes (Table 3) and from the table of refrigerant piping sizes (Table 8). 2) If the longest main piping length (LM) exceeds 50 m, increase the main piping size at the portion before 50 m by 1 rank for the suction pipes and discharge pipes. Use a field supply reducer. Determine the length less than the limitation of allowable maximum piping length. For the portion that exceeds 50 m, set based on the main piping size (LA) listed in Table 3. 3) If the piping length marked "L" (L2-L4) exceeds 40 m, increase the piping size at the portion after the 1st distribution joint by 1 rank for the liquid pipe, suction pipe and discharge pipe. Refer to the Technical Data for the details. 4) If any of the piping length exceeds 30 m, increase the size of the suction pipes, discharge pipes and liquid pipes by 1 rank.  
 \*The outdoor connection main piping (LO portion) is determined by the total capacity of the outdoor units that are connected to the pipe ends.

#### System limitations.

Maximum number allowable connected outdoor units	3
Maximum capacity allowable connected outdoor units	135 kW (48 HP)
Maximum connectable indoor units	52
Maximum allowable indoor / outdoor capacity ratio	50-150%

1) In the case of 24 HP (type 68 kW) or smaller units, the number is limited by the total capacity of the connected indoor units.  
 2) Up to 3 units can be connected if the system has been extended.  
 3) It is strongly recommended that you choose the unit so the load can become between 50 and 130%.

#### Additional refrigerant charge.

Liquid piping size (Inch (mm))	1/4 (6,35)	3/8 (9,52)	1/2 (12,70)	5/8 (15,88)	3/4 (19,05)	7/8 (22,22)
Amount of refrigerant charge (g/m)	26	56	128	185	259	366

#### Necessary amount of additional refrigerant charge per meter, according to discharge piping size.

Discharge piping size	Inch (mm)	1/2 (12,70)	5/8 (15,88)	3/4 (19,05)	7/8 (22,22)	1 (25,40)	1-1/8 (28,58)	1-1/4 (31,75)	1-1/2 (38,10)
Additional amount	g/m	12	21	31	41	55	71	89	126

#### Refrigerant piping.

Piping size (mm)				Material Temper - 1/2 H, H							
Material Temper - O				Material Temper - 1/2 H, H							
$\phi 6,35$	t 0,8	$\phi 12,70$	t 0,8	$\phi 19,05$	t 1,2	$\phi 22,22$	t 1,0	$\phi 28,58$	t 1,0	$\phi 38,10$	t 1,15
$\phi 9,52$	t 0,8	$\phi 15,88$	t 1,0			$\phi 25,40$	t 1,0	$\phi 31,75$	t 1,1	$\phi 41,28$	t 1,20

\*When bending the tubes, use a bending radius that is at least 4 times the outer diameter of the tubes. In addition, take sufficient care to avoid crushing or damaging the tubes when bending them.

### 3-Pipe ECOi EX MF3 Series - R410A

#### Simultaneous heating and cooling operation with heat recovery type.

The 3-Pipe ECOi EX MF3 Series is one of the most advanced VRF systems.

Not only highly efficient performance for simultaneous heating and cooling, but also sophisticated installation and maintenance capability.

4,85  
SCOP



HP			8 HP	10 HP	12 HP	14 HP	16 HP
Outdoor unit			U-8MF3E8	U-10MF3E8	U-12MF3E8	U-14MF3E8	U-16MF3E8
Power supply	Voltage	V	380-400-415	380-400-415	380-400-415	380-400-415	380-400-415
	Phase		Three phase	Three phase	Three phase	Three phase	Three phase
	Frequency	Hz	50	50	50	50	50
Cooling capacity		kW	22,4	28,0	33,5	40,0	45,0
EER <sup>1)</sup>		W/W	5,11	4,72	3,91	3,70	3,49
Current		A	7,16 - 6,80 - 6,55	9,90 - 9,41 - 9,07	3,19 - 13,20 - 12,70	18,20 - 17,30 - 16,70	21,30 - 20,20 - 19,50
Input power		kW	4,38	5,93	8,57	10,80	12,90
Heating capacity		kW	25,0	31,5	37,5	45,0	50,0
COP <sup>1)</sup>		W/W	5,25	5,17	4,51	4,21	4,17
Current		A	7,78 - 7,39 - 7,12	10,20 - 9,66 - 9,31	13,40 - 12,80 - 12,30	18,10 - 17,20 - 16,50	20,00 - 19,00 - 18,30
Input power		kW	4,76	6,09	8,32	10,70	12,00
Starting current		A	1,00	1,00	1,00	2,00	2,00
External static pressure (Max)		Pa	80	80	80	80	80
Air flow		m <sup>3</sup> /min	210	220	232	232	232
Sound pressure	Normal mode	dB(A)	54,0	57,0	60,0	61,0	62,0
	Silent mode 1 / 2	dB(A)	51,0/49,0	54,0/52,0	57,0/55,0	58,0/56,0	59,0/57,0
Sound power	Normal mode	dB(A)	76,0	78,0	81,0	82,0	82,0
Dimension	HxWxD	mm	1842x1180x1000	1842x1180x1000	1842x1180x1000	1842x1180x1000	1842x1180x1000
Net weight		kg	261	262	286	334	334
Piping diameter <sup>2)</sup>	Liquid	Inch (mm)	3/8(9,52)/1/2(12,70)	3/8(9,52)/1/2(12,70)	1/2(12,70)/5/8(15,88)	1/2(12,70)/5/8(15,88)	1/2(12,70)/5/8(15,88)
	Discharge	Inch (mm)	5/8(15,88)/3/4(19,05)	3/4(19,05)/7/8(22,22)	3/4(19,05)/7/8(22,22)	7/8(22,22)/1(25,40)	7/8(22,22)/1(25,40)
	Suction	Inch (mm)	3/4(19,05)/7/8(22,22)	7/8(22,22)/1(25,40)	1(25,40)/1-1/8(28,58)	1(25,40)/1-1/8(28,58)	1-1/8(28,58)/1-1/4(31,75)
	Balance	Inch (mm)	1/4(6,35)	1/4(6,35)	1/4(6,35)	1/4(6,35)	1/4(6,35)
Refrigerant (R410A) / CO <sub>2</sub> Eq.		kg / T	6,80/14,1984	6,80/14,1984	8,30/17,3304	8,30/17,3304	8,30/17,3304
Maximum allowable indoor / outdoor capacity ratio		%	50 ~ 150	50 ~ 150	50 ~ 150	50 ~ 150	50 ~ 150
Operating range	Cool Min - Max	°C	-10 ~ +52	-10 ~ +52	-10 ~ +52	-10 ~ +52	-10 ~ +52
	Heat Min - Max	°C	-20 ~ +18	-20 ~ +18	-20 ~ +18	-20 ~ +18	-20 ~ +18
	Simultaneous op.	°C	-10 ~ +24	-10 ~ +24	-10 ~ +24	-10 ~ +24	-10 ~ +24

#### ErP data <sup>3)</sup>

SEER <sup>4)</sup>	7,02	7,05	6,39	6,69	6,02
$\eta_{s,c}$	277,7%	278,9%	252,7%	264,4%	237,7%
SCOP <sup>4)</sup>	4,85	4,25	4,27	4,13	3,81
$\eta_{s,h}$	190,9%	166,8%	167,8%	162,1%	149,3%

1) EER and COP calculation is based in accordance to EN 14511. 2) Piping diameter under 90 m for ultimate indoor unit / over 90 m for ultimate indoor unit (if the longest piping equivalent length exceeds 90 m, increase the sizes of the main tubes by 1 rank for gas tubes and liquid tubes). 3) SEER / SCOP and  $\eta_{s,c}$  /  $\eta_{s,h}$  are in accordance with ErP test data for F2 type variable static pressure hide-away indoor units. 4) SEER / SCOP is calculated based on the seasonal space cooling / heating efficiency " $\eta$ " values of the COMMISSION REGULATION (EU) 2016/2281. SEER, SCOP = ( $\eta$  + Correction) × PEF.

#### Solenoid valve kit

<b>KIT-P56HR3</b>	3-Pipe control solenoid valve kit (up to 5,6 kW)
<b>CZ-P56HR3</b>	Solenoid valve kit (up to 5,6 kW)
<b>CZ-CAPE2</b>	3-Pipe control PCB
<b>KIT-P160HR3</b>	3-Pipe control solenoid valve kit (from 5,6 to 16,0 kW)
<b>CZ-P160HR3</b>	Solenoid valve kit (from 5,6 kW to 16,0 kW)
<b>CZ-CAPE2</b>	3-Pipe control PCB
<b>CZ-CAPE2 <sup>5)</sup></b>	3-Pipe control PCB for wall-mounted

#### 3-Pipe control box kit

<b>CZ-P456HR3</b>	4 ports 3 pipe box (up to 5,6 kW per port)
<b>CZ-P656HR3</b>	6 ports 3 pipe box (up to 5,6 kW per port)
<b>CZ-P856HR3</b>	8 ports 3 pipe box (up to 5,6 kW per port)
<b>CZ-P4160HR3</b>	4 ports 3 pipe box (up to 16,0 kW per port)

5) Available for S-45/56/73/106MK3E.

- Achieving SCOP 4,85 top class in the industry (LOT21 Seasonal heating efficiency value for 8 HP outdoor unit)
- Simultaneous cooling and heating operation with up to 39 indoor units
- Slim heat recovery boxes with just 200 mm height fit with the ceiling space limited in hotel applications

#### Technical focus

- High SEER / SCOP at full Load capacity (follows LOT21)
- Eurovent certified EER / COP
- Standardisation of outdoor unit to one compact casing size
- Connection of up to 52 indoor units
- High external static pressure 80 Pa with an efficient fan shape, fan guard, motor, and casing
- Silent outdoor unit operation: Minimum 54 dB(A) for 8 HP
- Bluefin coil coating as standard



## 3-Pipe ECOi EX MF3 Series - R410A - Combination from 18 to 48 HP

HP			18 HP	20 HP	22 HP	24 HP	26 HP	28 HP	30 HP	32 HP
Outdoor unit			U-8MF3E8	U-8MF3E8	U-10MF3E8	U-12MF3E8	U-10MF3E8	U-12MF3E8	U-14MF3E8	U-16MF3E8
			U-10MF3E8	U-12MF3E8	U-12MF3E8	U-12MF3E8	U-16MF3E8	U-16MF3E8	U-16MF3E8	U-16MF3E8
Power supply	Voltage	V	380-400-415	380-400-415	380-400-415	380-400-415	380-400-415	380-400-415	380-400-415	380-400-415
	Phase		Three phase	Three phase	Three phase	Three phase	Three phase	Three phase	Three phase	Three phase
	Frequency	Hz	50	50	50	50	50	50	50	50
Cooling capacity	kW		50,0	56,0	61,5	68,0	73,0	78,5	85,0	90,0
EER <sup>1)</sup>	W/W		4,90	4,31	4,24	3,89	3,88	3,65	3,59	3,49
Current	A		16,80-16,00-15,40	21,00-20,00-19,20	23,70-22,50-21,70	28,30-26,90-25,90	31,00-29,50-28,40	35,10-33,40-32,20	39,60-37,60-36,20	42,60-40,50-39,00
Input power	kW		10,20	13,00	14,50	17,50	18,80	21,50	23,70	25,8
Heating capacity	kW		56,0	63,0	69,0	76,5	81,5	87,5	95,0	100,0
COP <sup>1)</sup>	W/W		5,23	4,77	4,79	4,47	4,50	4,31	4,19	4,17
Current	A		17,70-16,80-16,20	21,30-20,30-19,50	23,50-22,30-21,50	27,60-26,30-25,30	30,20-28,70-27,70	33,50-31,80-30,70	37,90-36,00-34,70	40,10-38,10-36,70
Input power	kW		10,70	13,20	14,40	17,10	18,10	20,30	22,70	24,00
Starting current	A		2,00	2,00	2,00	2,00	3,00	3,00	4,00	4,00
External static pressure (Max)	Pa		80	80	80	80	80	80	80	80
Air flow	m <sup>3</sup> /min		430	442	452	464	452	464	464	464
Sound pressure	Normal mode	dB(A)	59,0	61,0	62,0	63,0	63,5	64,5	64,5	65,0
	Silent mode 1 / 2	dB(A)	56,0/54,0	58,0/56,0	59,0/57,0	60,0/58,0	60,5/58,5	61,5/59,5	61,5/59,5	62,0/60,0
Sound power	Normal mode	dB(A)	81,5	84,0	84,5	86,0	84,5	86,0	86,0	86,0
Dimension	HxWxD	mm	1842 x 2360 (+60) x 1000	1842 x 2360 (+60) x 1000	1842 x 2360 (+60) x 1000	1842 x 2360 (+60) x 1000	1842 x 2360 (+60) x 1000	1842 x 2360 (+60) x 1000	1842 x 2360 (+60) x 1000	1842 x 2360 (+60) x 1000
Net weight	kg		523	547	548	574	596	620	668	668
Piping diameter <sup>2)</sup>	Liquid	Inch (mm)	5/8(15,88)/ 3/4(19,05)	5/8(15,88)/ 3/4(19,05)	5/8(15,88)/ 3/4(19,05)	5/8(15,88)/ 3/4(19,05)	3/4(19,05)/ 7/8(22,22)	3/4(19,05)/ 7/8(22,22)	3/4(19,05)/ 7/8(22,22)	3/4(19,05)/ 7/8(22,22)
	Discharge	Inch (mm)	7/8(22,22)/ 1(25,40)	7/8(22,22)/ 1(25,40)	1(25,40)/ 1-1/8(28,58)	1(25,40)/ 1-1/8(28,58)	1(25,40)/ 1-1/8(28,58)	1-1/8(28,58)/ 1-1/4(31,75)	1-1/8(28,58)/ 1-1/4(31,75)	1-1/8(28,58)/ 1-1/4(31,75)
	Suction	Inch (mm)	1-1/8(28,58)/ 1-1/4(31,75)	1-1/8(28,58)/ 1-1/4(31,75)	1-1/8(28,58)/ 1-1/4(31,75)	1-1/8(28,58)/ 1-1/4(31,75)	1-1/4(31,75)/ 1-1/2(38,10)	1-1/4(31,75)/ 1-1/2(38,10)	1-1/4(31,75)/ 1-1/2(38,10)	1-1/4(31,75)/ 1-1/2(38,10)
	Balance	Inch (mm)	1/4(6,35)	1/4(6,35)	1/4(6,35)	1/4(6,35)	1/4(6,35)	1/4(6,35)	1/4(6,35)	1/4(6,35)
Refrigerant (R410A) / CO <sub>2</sub> Eq.	kg / T		13,60/28,3968	15,10/31,5288	15,10/31,5288	16,60/34,6608	15,10/31,5288	16,60/34,6608	16,60/34,6608	16,60/34,6608
Maximum allowable indoor / outdoor capacity ratio	%		50 ~ 150	50 ~ 150	50 ~ 150	50 ~ 150	50 ~ 150	50 ~ 150	50 ~ 150	50 ~ 150
Operating range	Cool Min ~ Max	°C	-10 ~ +52	-10 ~ +52	-10 ~ +52	-10 ~ +52	-10 ~ +52	-10 ~ +52	-10 ~ +52	-10 ~ +52
	Heat Min ~ Max	°C	-20 ~ +18	-20 ~ +18	-20 ~ +18	-20 ~ +18	-20 ~ +18	-20 ~ +18	-20 ~ +18	-20 ~ +18
	Simultaneous op.	°C	-10 ~ +24	-10 ~ +24	-10 ~ +24	-10 ~ +24	-10 ~ +24	-10 ~ +24	-10 ~ +24	-10 ~ +24

HP			34 HP	36 HP	38 HP	40 HP	42 HP	44 HP	46 HP	48 HP
Outdoor unit			U-8MF3E8	U-8MF3E8	U-10MF3E8	U-8MF3E8	U-10MF3E8	U-12MF3E8	U-14MF3E8	U-16MF3E8
			U-10MF3E8	U-12MF3E8	U-12MF3E8	U-16MF3E8	U-16MF3E8	U-16MF3E8	U-16MF3E8	U-16MF3E8
			U-16MF3E8	U-16MF3E8	U-16MF3E8	U-16MF3E8	U-16MF3E8	U-16MF3E8	U-16MF3E8	U-16MF3E8
Power supply	Voltage	V	380-400-415	380-400-415	380-400-415	380-400-415	380-400-415	380-400-415	380-400-415	380-400-415
	Phase		Three phase	Three phase	Three phase	Three phase	Three phase	Three phase	Three phase	Three phase
	Frequency	Hz	50	50	50	50	50	50	50	50
Cooling capacity	kW		96,0	101,0	107,0	113,0	118,0	124,0	130,0	135,0
EER <sup>1)</sup>	W/W		4,10	3,90	3,88	3,72	3,72	3,58	3,55	3,49
Current	A		38,60-36,70-35,40	42,30-40,20-38,70	45,60-43,30-41,70	50,20-47,70-46,00	52,40-49,70-47,90	56,50-53,70-51,80	61,10-58,10-56,00	63,90-60,70-58,50
Input power	kW		23,40	25,90	27,60	30,40	31,70	34,60	36,60	38,70
Heating capacity	kW		108,0	113,0	119,0	127,0	132,0	138,0	145,0	150,0
COP <sup>1)</sup>	W/W		4,64	4,48	4,51	4,31	4,36	4,25	4,18	4,17
Current	A		38,90-37,00-35,60	41,60-39,50-38,10	43,60-41,40-39,90	49,30-46,80-45,10	50,60-48,10-46,30	53,70-51,00-49,10	57,90-55,00-53,00	60,10-57,10-55,00
Input power	kW		23,30	25,20	26,40	29,50	30,30	32,50	34,70	36,00
Starting current	A		4,00	4,00	4,00	5,00	5,00	5,00	6,00	6,00
External static pressure (Max)	Pa		80	80	80	80	80	80	80	80
Air flow	m <sup>3</sup> /min		662	674	684	674	684	696	696	696
Sound pressure	Normal mode	dB(A)	64,0	64,5	65,0	65,5	66,0	66,5	66,5	67,0
	Silent mode 1 / 2	dB(A)	61,0/59,0	61,5/59,5	62,0/60,0	62,5/60,5	63,0/61,0	63,5/61,5	63,5/61,5	64,0/62,0
Sound power	Normal mode	dB(A)	84,5	85,5	85,5	85,5	86,0	86,5	87,0	87,0
Dimension	HxWxD	mm	1842 x 3540 (+120) x 1000	1842 x 3540 (+120) x 1000	1842 x 3540 (+120) x 1000	1842 x 3540 (+120) x 1000	1842 x 3540 (+120) x 1000	1842 x 3540 (+120) x 1000	1842 x 3540 (+120) x 1000	1842 x 3540 (+120) x 1000
Net weight	kg		857	881	882	929	930	954	1002	1002
Piping diameter <sup>2)</sup>	Liquid	Inch (mm)	3/4(19,05)/ 7/8(22,22)	3/4(19,05)/ 7/8(22,22)	3/4(19,05)/ 7/8(22,22)	3/4(19,05)/ 7/8(22,22)	3/4(19,05)/ 7/8(22,22)	3/4(19,05)/ 7/8(22,22)	3/4(19,05)/ 7/8(22,22)	3/4(19,05)/ 7/8(22,22)
	Discharge	Inch (mm)	1-1/8(28,58)/ 1-1/4(31,75)	1-1/8(28,58)/ 1-1/4(31,75)	1-1/4(31,75)/ 1-1/2(38,10)	1-1/4(31,75)/ 1-1/2(38,10)	1-1/4(31,75)/ 1-1/2(38,10)	1-1/4(31,75)/ 1-1/2(38,10)	1-1/4(31,75)/ 1-1/2(38,10)	1-1/4(31,75)/ 1-1/2(38,10)
	Suction	Inch (mm)	1-1/4(31,75)/ 1-1/2(38,10)	1-1/2(38,10)/ 1-5/8(41,28)	1-1/2(38,10)/ 1-5/8(41,28)	1-1/2(38,10)/ 1-5/8(41,28)	1-1/2(38,10)/ 1-5/8(41,28)	1-1/2(38,10)/ 1-5/8(41,28)	1-1/2(38,10)/ 1-5/8(41,28)	1-1/2(38,10)/ 1-5/8(41,28)
	Balance	Inch (mm)	1/4(6,35)	1/4(6,35)	1/4(6,35)	1/4(6,35)	1/4(6,35)	1/4(6,35)	1/4(6,35)	1/4(6,35)
Refrigerant (R410A) / CO <sub>2</sub> Eq.	kg / T		21,90/45,72719	23,40/48,85919	23,40/48,85919	23,40/48,85919	23,40/48,85919	24,90/46,3536	24,90/51,9912	24,90/51,9912
Maximum allowable indoor / outdoor capacity ratio	%		50 ~ 150	50 ~ 150	50 ~ 150	50 ~ 150	50 ~ 150	50 ~ 150	50 ~ 150	50 ~ 150
Operating range	Cool Min ~ Max	°C	-10 ~ +52	-10 ~ +52	-10 ~ +52	-10 ~ +52	-10 ~ +52	-10 ~ +52	-10 ~ +52	-10 ~ +52
	Heat Min ~ Max	°C	-20 ~ +18	-20 ~ +18	-20 ~ +18	-20 ~ +18	-20 ~ +18	-20 ~ +18	-20 ~ +18	-20 ~ +18
	Simultaneous op.	°C	-10 ~ +24	-10 ~ +24	-10 ~ +24	-10 ~ +24	-10 ~ +24	-10 ~ +24	-10 ~ +24	-10 ~ +24

1) EER and COP calculation is based in accordance to EN 14511. 2) Piping diameter under 90 m for ultimate indoor unit / over 90 m for ultimate indoor unit (if the longest piping equivalent length exceeds 90 m, increase the sizes of the main tubes by 1 rank for gas tubes and liquid tubes).

# Leak detection and automatic Pump Down for R410A refrigerant

Pump Down Systems to detect refrigerant leaks, that offers complete assurance and safety protection. It's an ideal solution for hotels, offices and public buildings where the strict safety of end users and workers is required.



The system monitors refrigerant leakage continually and provides a warning, preventing major refrigerant loss and potential damage to the installation's efficiency. The system can reduce potential refrigerant loss by up to 90%.

As well as ensuring safe and reliable operation, Panasonic's Pump Down system contributes towards BREEAM POL1 points and enables compliance with current EN 378 standards, covering applications where refrigeration concentration levels exceed practical safety limits of 0,44 kg/m<sup>3</sup>.

## Basic Pump Down function:

- Leak detection
- Activate Pump Down process
- Collect refrigerant within receiver tank
- Close valves to isolate refrigerant

## Technical focus:

- Compatible with Mini ECOi and ECOi EX Series with R410A refrigerant
- A receiver kit included as standard
- Includes updated controller
- Connection in two ways:
  - 1 |** With local room leakage sensors
  - 2 |** Using innovative algorithm
- R22 renewal possible



## The Pump Down systems are ideal for hotels, offices and public buildings where safety of building occupants is a must.

### Direct leak detection method: the safest solution for small rooms

The leak detector is connected directly to the indoor unit and the Pump Down system is directly connected to the outdoor unit PCB. The Pump Down system will activate when a leak is detected in the room and initiate a refrigerant reclaim operation immediately. This immediate reaction, and large refrigerant storage capacity, offers very high levels of safety for end users, building occupants, as well as being climate-friendly.

No additional communication panels or software is required. This option should be implemented in any area that is not compliant with BS EN 378.

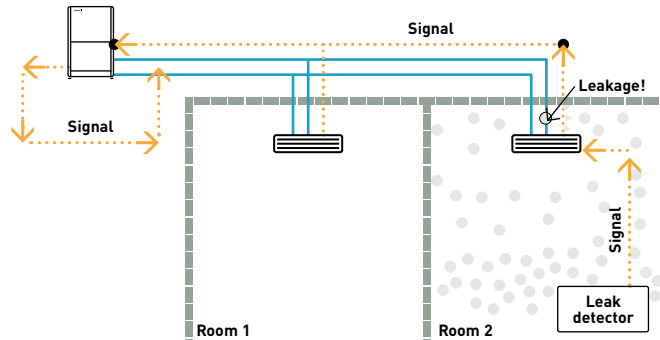

### Indirect leak detection method: Unique PLC algorithm to determine refrigerant leakage

Pressure and temperature sensors constantly monitor the high / low pressure and discharge of the condensing unit to protect against potential leakage in areas not covered by leak detectors.

The innovative algorithm is able to detect leakage of R410A based on abnormal changes in the following conditions, high and low pressure, and compressor discharge temperature.

Once initiated via either direct or indirect detection, the unit will immediately close the liquid / discharge actuating ball valves, close the alarm terminals on the Pump Down PCB allowing an alarm to be raised at any nominated location. Reclaim of the refrigerant is via the suction line to the heat exchanger(s) of the outdoor unit(s), with any surplus refrigerant collected in the 30 l receiver tank. Once fully pumped down the suction line is closed and the unit awaits a 'Reset' and 'Recharge' command.

Thanks to the simple installation and control, shown in Fig 1, Panasonic's ECOi Pump Down system can provide dramatic reduction in capital cost and installation time when compared to a standalone leak detection system, shown in Fig 2.

Fig 1: Panasonic's Pump Down system.

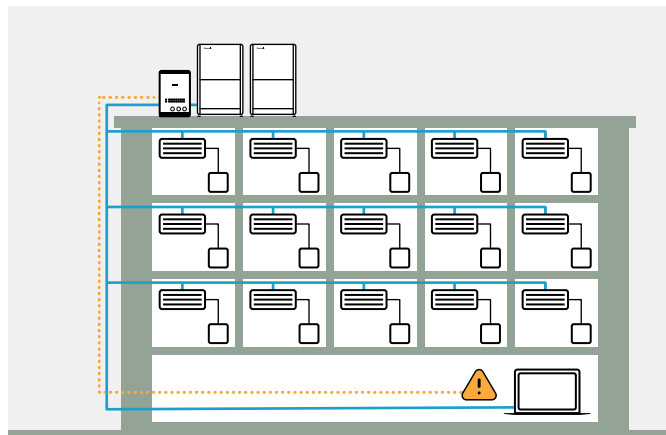
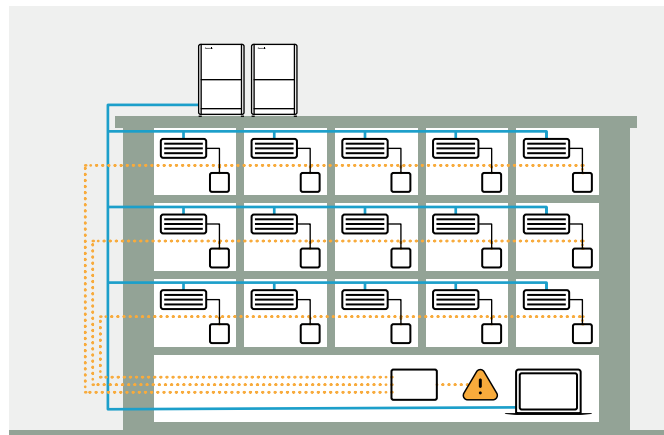

Fig 2: Standalone leak detection system.



### Quick and simple installation

The unit contains actuating ball valves, a 30 L storage vessel and PLC all housed in an IP54 rated encasement. Terminals in front of the unit allow easy wiring to the alarm terminal, high / low pressure transducers and discharge temperature sensor(s) of the condensing unit(s).

Reference	Description
PAW-PUD2W-1R	Pump Down system (2 way) for 1 outdoor unit
PAW-PUD2W-2R	Pump Down system (2 way) for 2 outdoor units
PAW-PUD2W-3R*	Pump Down system (2 way) for 3 outdoor units
PAW-PUD3W-1R	Pump Down system (3 way) for 1 outdoor unit
PAW-PUD3W-2R	Pump Down system (3 way) for 2 outdoor units
PAW-PUD3W-3R*	Pump Down system (3 way) for 3 outdoor units





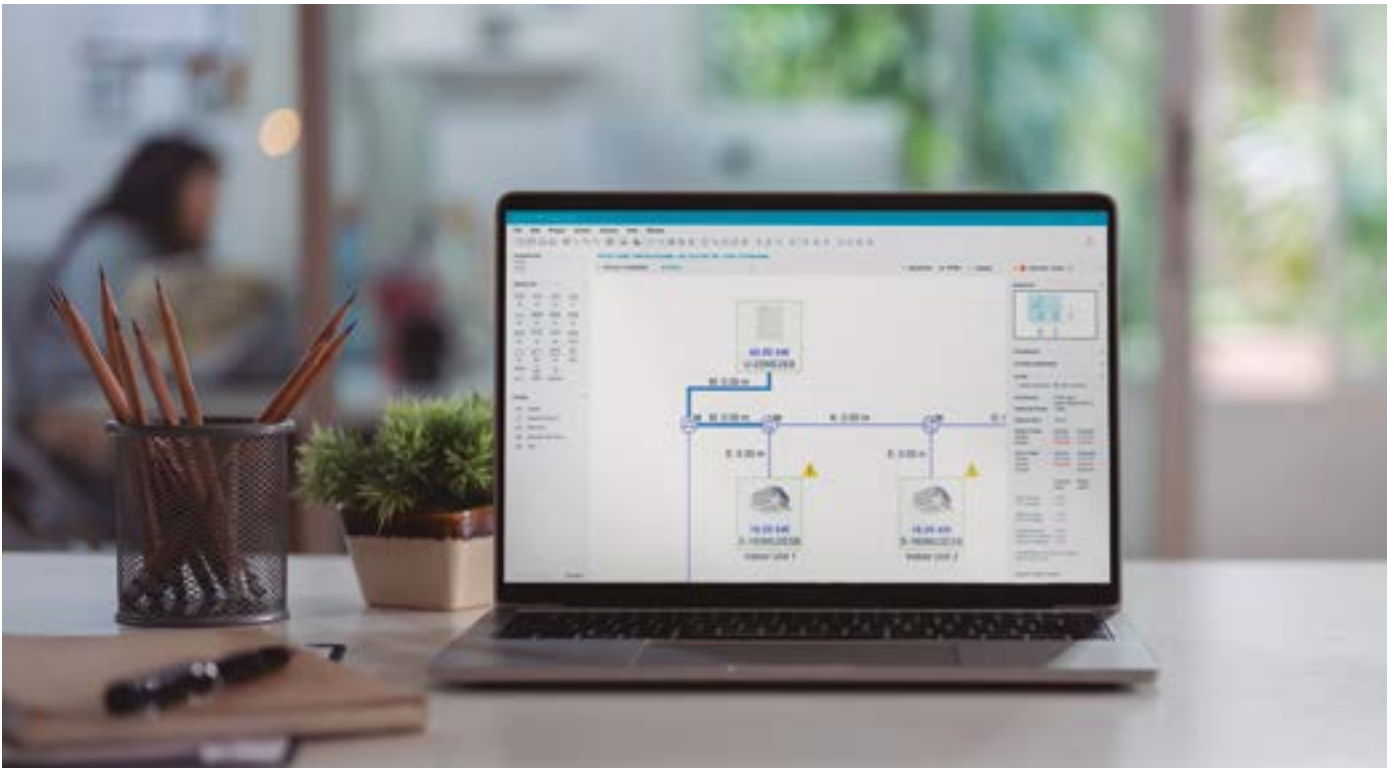

\*Special order requiring the longer lead time than usual. For the detailed information, please contact an authorized Panasonic dealer.

# Panasonic DX PRO Designer

Leading software for architects, designers, and consultants, specializing in the design of commercial DX heating and cooling systems.



Cloud based solution: Access from anywhere 24/7/365, collaborative work with your team and the software is consistently updated to the latest version.

					
Cloud based tool.	Design on building floor drawing.	Auto piping and wiring diagram.	Performance calculation.	Comprehensive project report.	Floor drawing image import.

## DX PRO Designer offers improved user experience and useful functions for the heating and cooling experts

- Seasonal performance calculation in accordance with ERP directive and EN14825 standard
- Designing heating and cooling systems for floor-level building design
- Automatic piping and wiring function
- Limit density check function in accordance with IEC 60335-2-40 / EN 378
- Comprehensive project report available
- Multi language supports

**The software performs seasonal performance calculations, considering on-site conditions.**



**Download the comprehensive project report.**



Let's try out the DX PRO Designer\*



\*Panasonic PRO Club account is required.

The video for detailed information is ready!



## Panasonic VRF service checker

Available to installers and commissioning companies, the VRF service checker is a communication interface to Panasonic VRF systems. This easy to manage tool checks all parameters of the system.

### The VRF service checker.

- Connect anywhere on the S-Link for ECOi and Mini ECOi
- Search the S-Link to validate systems that are connected
- Monitor all indoor and outdoor units simultaneously on 1 screen
- Monitor all Temperature data, Pressure data, Valve position, and alarm status
- Data can be viewed in Graph or tabular display
- Controlling the indoor unit ON / OFF, MODE, SET POINT, FAN, and TEST mode
- Switch between various systems on the same communication S-Link (ECOi only)
- Monitor and record at a set interval
- Record and review the data at a later date
- Update Panasonic system software via ROM flash writer

The Panasonic VRF service checker is available from your local service partner.

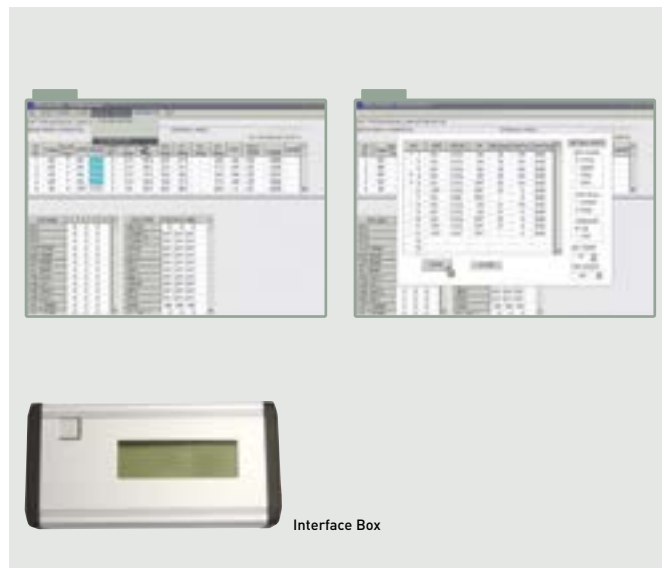

## R22 Renewal

Panasonic's advanced technology enables the system to work with previously installed pipe work by managing the working pressure within the system down to R22 (33 bar) levels, this ensures the system works safely and efficiently without loss of capacity.

The new equipment can offer increased COP / EER by using state of the art Inverter compressor and heat exchanger technology.

Having contacted your Panasonic supplier regarding pipe work restrictions, and gained approval to use the Panasonic Renewal System, there are three main tests that have to be carried out to ensure that the system can be used effectively. Firstly a thorough inspection of the pipe work must be carried out and any damage must be repaired. Secondly an oil test must be performed to ensure that the system has not been subject to a compressor burnout during its lifetime. Lastly a VRF Renewal Kit (CZ-SLK2) must be installed within the pipe work to ensure that the system is cleaned and free of oil remnants.



# VRF indoor units range

Page	Indoor units	1,0 kW	1,5 kW	2,2 kW	2,8 kW	3,6 kW	4,5 kW	5,6 kW
P. 63	U2 type 4 way 90x90 cassette · R32 / R410A			 S-22MU2E5C	 S-28MU2E5C	 S-36MU2E5C	 S-45MU2E5C	 S-56MU2E5C
P. 64	Y3 type 4 way 60x60 cassette · R32 / R410A	 S-15MY3EB	 S-22MY3EB	 S-28MY3EB	 S-36MY3EB	 S-45MY3EB	 S-56MY3EB	
P. 65	L1 type 2 way cassette · R410A			 S-22ML1E5	 S-28ML1E5	 S-36ML1E5	 S-45ML1E5	 S-56ML1E5
P. 66	D1 type 1 way cassette · R410A				 S-28MD1E5	 S-36MD1E5	 S-45MD1E5	 S-56MD1E5
P. 67	F3 type variable static pressure adaptive duct · R32 / R410A	 S-15MF3E5D	 S-22MF3E5D	 S-28MF3E5D	 S-36MF3E5D	 S-45MF3E5D	 S-56MF3E5D	
P. 68	M2 type slim variable static pressure hide-away · R32 / R410A	 S-10MM2EB	 S-15MM2EB	 S-22MM2EB	 S-28MM2EB	 S-36MM2EB	 S-45MM2EB	 S-56MM2EB
P. 69	E2 type high static pressure hide-away · R410A							
P. 71	K3 type wall-mounted · R32 / R410A	 S-15MK3E	 S-22MK3E	 S-28MK3E	 S-36MK3E	 S-45MK3E	 S-56MK3E	
P. 72	T2 type ceiling · R410A					 S-36MT2E5A	 S-45MT2E5A	 S-56MT2E5A
P. 73	G1 type floor console · R410A			 S-22MG1E5N	 S-28MG1E5N	 S-36MG1E5N	 S-45MG1E5N	 S-56MG1E5N
P. 74	NEW! P2 type floor-standing · R32 / R410A			 S-22MP2E	 S-28MP2E	 S-36MP2E	 S-45MP2E	 S-56MP2E
P. 74	NEW! R2 type concealed floor-standing · R32 / R410A			 S-22MR2E	 S-28MR2E	 S-36MR2E	 S-45MR2E	 S-56MR2E
P. 75	Hydrokit for ECOi, water at 45 °C · R410A							
P. 77	2-Pipe ECOi EX ME2 Series with water heat exchanger · R410A							
P. 83	Energy recovery ventilation with DX coil – HRPT Series · R32 / R410A			 PAW-HRPT40 (2,5 kW)				 PAW-HRPT80 (5 kW)

OPTIONAL UNITS ON VENTILATION SECTION 

6,0 kW

7,3 kW

9,0 kW

10,6 kW

11,2 kW

14,0 kW

16,0 kW

22,4 kW

28,0 kW



S-60MU2E5C



S-73MU2E5C



S-90MU2E5C



S-112MU2E5C



S-140MU2E5C



S-160MU2E5C

A panel in graphite black (RAL9011) is available.



A new panel in graphite black (RAL9011) is available.



S-73ML1E5



S-73MD1E5



S-60MF3E5D



S-73MF3E5D



S-90MF3E5D



S-112MF3E5D



S-140MF3E5D



S-160MF3E5D



S-224ME2E5



S-280ME2E5

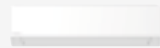

S-73MK3E

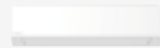

S-106MK3E



S-73MT2E5A



S-106MT2E5A



S-140MT2E5A



S-71MP2E



S-71MR2E



S-80MW1E5



S-125MW1E5



PAW-250WP5G1  
PAW-250W5G1



PAW-500WP5G1  
PAW-500W5G1 (50 kW)



PAW-HRPT120HX  
PAW-HRPT120 (7 kW)



PAW-HRPT160HX  
PAW-HRPT160 (10 kW)



PAW-HRPT200HX  
PAW-HRPT200 (12,5 kW)

# 4 way 90x90 cassette with nanoe X Generator Mark 3



Large capacity VRF. Trusted power and high-efficiency. These Cassettes offer upgraded nanoe™ X technology and Econavi as accessories for making application space more comfortable and efficient.

White and graphite black panels now available for the 4 way 90x90 cassette, offering versatile options for commercial applications.



Standard panel, white (RAL9003). CZ-KPU3

Standard panel, graphite black (RAL9011). CZ-KPU3B

Econavi panel, white (RAL9003). CZ-KPU3A



## Always fresh and clean air with nanoe™ X

The 4 way 90x90 cassette with nanoe™ X, when tested, has shown to inhibit hazardous substances by 92%, when compared to natural reduction\*. In addition to the 7 effects of nanoe™ X, the indoor unit can also be cleaned with a short operation of nanoe™ X and dry operation.

\*Controllers (CZ-RTC5B or CZ-RTC6/BL) are required.

After cooling/drying operation, the inside of the indoor unit is automatically dried and nanoe™ X is activated to suppress mould growth.

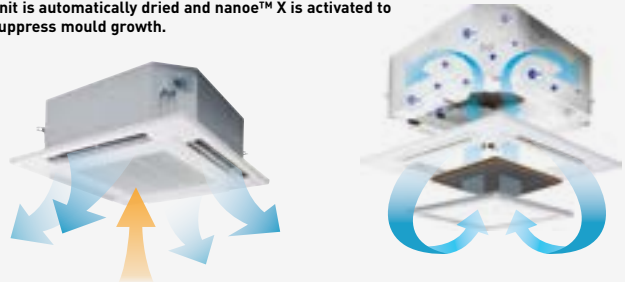

Operates the fan to discharge internal humidity.

Operate the fan to circulate nanoe™ X internally.

## Optional Econavi intelligent sensor

Human activity sensor and floor temperature sensor can reduce waste energy, by optimising air conditioner operation.

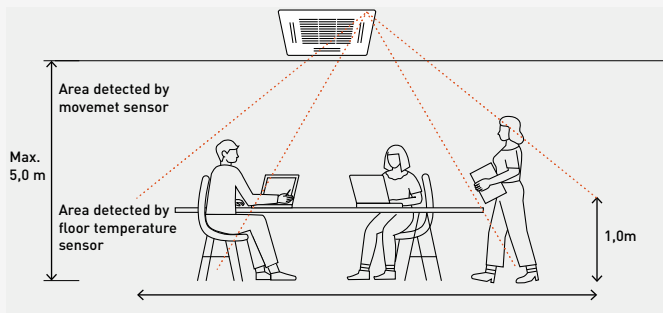

## Advanced Econavi functions.

2 sensors (movement and floor temperature) can provide a reduction in wasted energy by means of effective control. The floor temperature can be detected with a ceiling height of up to 5 m.



Econavi exclusive panel. Optional (CZ-KPU3A).

**Floor temperature sensor.** This sensor detects average floor temperature and operates circulation if floor temperature is low.

**Movement sensor.** This sensor detects the amount of human activity, and operates effectively.

Wired remote controller CZ-RTC5B, CZ-RTC6W/BL or CZ-RTC6/BL is required.

## Humidity sensor.

A humidity sensor positioned in the air inlet provides comfort and saves energy based on temperature and humidity.

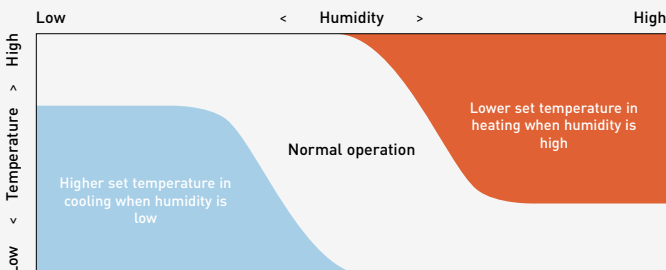

## Group control, circulation function.

Circulating operation is activated when a room is unoccupied to evenly distribute air and minimize thermal stratification in both heating and cooling operation.

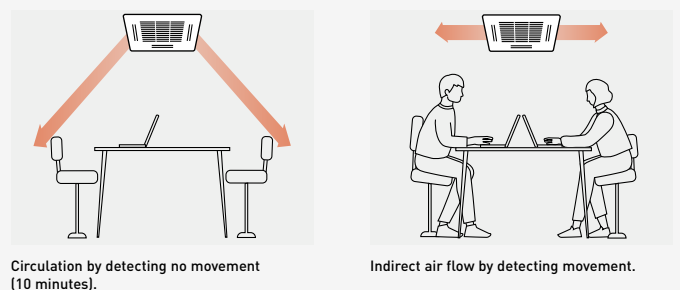



## Panels (sold separately):

Standard, white  
(RAL9003).  
CZ-KPU3

Econavi, white  
(RAL9003).  
CZ-KPU3A

Standard, graphite  
black (RAL9011).  
CZ-KPU3B



## U2 type 4 way 90x90 cassette - R32 / R410A

The 4 way 90x90 cassettes with integrated nanoe™ X Generator Mark 3 and design panel.

COMPATIBLE WITH ALL PANASONIC CONNECTIVITY SOLUTIONS. FOR DETAILED INFORMATION GO TO THE CONTROL SYSTEMS SECTION



Indoor unit. S-***MU2E5C		22	28	36	45	56	60	73	90	112	140	160	
Cooling capacity	kW	2,2	2,8	3,6	4,5	5,6	6,0	7,3	9,0	11,2	14,0	16,0	
Input power	W	20,00	20,00	20,00	20,00	25,00	35,00	40,00	40,00	95,00	95,00	105,00	
Current	A	0,21	0,21	0,21	0,21	0,23	0,33	0,36	0,38	0,74	0,74	0,82	
Heating capacity	kW	2,5	3,2	4,2	5,0	6,3	7,1	8,0	10,0	14,0	16,0	18,0	
Input power	W	20,00	20,00	20,00	20,00	25,00	35,00	40,00	40,00	90,00	90,00	100,00	
Current	A	0,20	0,20	0,20	0,20	0,22	0,32	0,35	0,37	0,72	0,72	0,80	
Fan type		Turbo fan	Turbo fan	Turbo fan	Turbo fan	Turbo fan	Turbo fan	Turbo fan	Turbo fan	Turbo fan	Turbo fan	Turbo fan	
nanoe X Generator		Mark 3	Mark 3	Mark 3	Mark 3	Mark 3	Mark 3	Mark 3	Mark 3	Mark 3	Mark 3	Mark 3	
Air flow	Hi/ Med/ Lo	m <sup>3</sup> /min	12,8/12,1/ 11,5	12,8/12,1/ 11,5	14,5/13,0/ 11,5	15,5/13,0/ 11,5	16,5/13,5/ 11,5	21,0/16,0/ 13,0	22,5/16,0/ 13,0	23,0/18,5/ 14,0	36,0/26,0/ 20,0	36,0/26,0/ 20,0	37,0/28,0/ 24,0
Sound pressure		dB(A)	30/29/28	30/29/28	30/29/28	31/29/28	32/30/28	36/32/29	37/32/29	38/35/32	45/39/35	45/39/35	46/40/38
Sound power		dB(A)	45/44/43	45/44/43	45/44/43	46/44/43	47/45/43	51/47/44	52/47/44	53/50/47	60/54/50	60/54/50	61/55/53
Dimension (H x W x D)	Indoor	mm	256 x 840 x 840	256 x 840 x 840	256 x 840 x 840	256 x 840 x 840	256 x 840 x 840	256 x 840 x 840	256 x 840 x 840	256 x 840 x 840	319 x 840 x 840	319 x 840 x 840	319 x 840 x 840
	Panel	mm	33,5 x 950 x 950	33,5 x 950 x 950	33,5 x 950 x 950	33,5 x 950 x 950	33,5 x 950 x 950	33,5 x 950 x 950	33,5 x 950 x 950	33,5 x 950 x 950	33,5 x 950 x 950	33,5 x 950 x 950	33,5 x 950 x 950
Net weight (Panel)	kg	20 (5)	20 (5)	20 (5)	20 (5)	20 (5)	20 (5)	20 (5)	20 (5)	25 (5)	25 (5)	25 (5)	
Piping diameter	Liquid	Inch (mm)	1/4 (6,35)	1/4 (6,35)	1/4 (6,35)	1/4 (6,35)	1/4 (6,35)	1/4 (6,35)	1/4 (6,35)	1/4 (6,35)	3/8 (9,52)	3/8 (9,52)	3/8 (9,52)
	Gas	Inch (mm)	1/2 (12,70)	1/2 (12,70)	1/2 (12,70)	1/2 (12,70)	1/2 (12,70)	1/2 (12,70)	1/2 (12,70)	1/2 (12,70)	5/8 (15,88)	5/8 (15,88)	5/8 (15,88)
Piping diameter	Liquid	Inch (mm)	1/4 (6,35)	1/4 (6,35)	1/4 (6,35)	1/4 (6,35)	1/4 (6,35)	3/8 (9,52) <sup>1)</sup>	3/8 (9,52) <sup>1)</sup>	3/8 (9,52) <sup>1)</sup>	3/8 (9,52)	3/8 (9,52)	3/8 (9,52)
	Gas	Inch (mm)	1/2 (12,70)	1/2 (12,70)	1/2 (12,70)	1/2 (12,70)	1/2 (12,70)	5/8 (15,88) <sup>1)</sup>	5/8 (15,88) <sup>1)</sup>	5/8 (15,88) <sup>1)</sup>	5/8 (15,88)	5/8 (15,88)	5/8 (15,88)

1) When the piping diameter is (liquid) Ø1/4 (6,35) – (gas) Ø1/2 (12,70), connect the liquid socket tube (Ø1/4 (6,35) – Ø3/8 (9,52)) to the liquid tubing side indoor unit and connect the gas socket tube (Ø1/2 (12,70) – Ø5/8 (15,88)) to the gas tubing side indoor unit.

## Accessories

<b>CZ-RTC6W</b>	CONEX wired remote controller (non-wireless), white
<b>CZ-RTC6WBL</b>	CONEX wired remote controller with Bluetooth®, white
<b>CZ-RTC6</b>	CONEX wired remote controller (non-wireless), black
<b>CZ-RTC6BL</b>	CONEX wired remote controller with Bluetooth®, black
<b>CZ-RTC5B</b>	Wired remote controller with Econavi function
<b>CZ-RWS3 + CZ-RWRU3</b>	Infrared remote controller and receiver
<b>PAW-RE2C4-MOD-WH</b>	Room controller for hotel rooms, white
<b>PAW-RE2C4-MOD-BK</b>	Room controller for hotel rooms, black

## Accessories

<b>PAW-RE2D4-WH</b>	Display control for hotel rooms, white
<b>PAW-RE2D4-BK</b>	Display control for hotel rooms, black
<b>CZ-KPU3</b>	Standard panel, white (RAL9003)
<b>CZ-KPU3B</b>	Standard panel, graphite black (RAL9011)
<b>CZ-KPU3A</b>	Econavi exclusive panel, white (RAL9003)
<b>CZ-CENSC1</b>	Econavi energy saving sensor
<b>CZ-FDU3+CZ-ATU2</b>	Fresh air-intake kit
<b>CZ-CGLSC2</b>	Panasonic R32 refrigerant leak detector

## Technical focus

- High performance turbo fan
- Lower noise in low fan operation
- Ceiling height up to 5,0 m
- Industry leading lightweight design
- Econavi: Temperature, humidity and activity sensor
- nanoe™ X (Generator Mark 3: 48 trillion hydroxyl radicals/sec) as standard for better indoor air quality, indoor unit internal cleaning with nanoe™ X and dry operation
- Powerful drain pump gives 850 mm lift
- Fresh air knockout
- Branch duct connection
- High volume fresh air input with optional air-intake plenum and chamber (CZ-FDU3+CZ-ATU2)
- Graphite black and white panels providing options to suit a variety of light commercial applications

## Panel design

A modern flat panel design blends into any space. These cassettes provide high energy saving, comfort and better indoor air quality that satisfy customers.

- Flat design, well-matched with interior aesthetic
- 4-way individual flap control

## The drain pipe can be raised to a maximum height of 850 mm from the bottom of the ceiling

Integrated drain pump allows a drain height of 850 mm making the installation much easier.

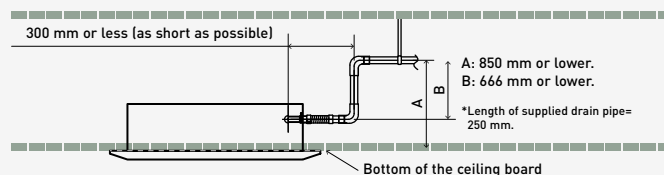

ECONAVI and INTERNET CONTROL: Optional.

Rating conditions: Cooling indoor 27 °C DB / 19 °C WB. Cooling outdoor 35 °C DB / 24 °C WB. Heating indoor 20 °C DB. Heating outdoor 7 °C DB / 6 °C WB. (DB: Dry Bulb, WB: Wet Bulb). Specifications subject to change without notice. For detailed information about ErP / Energy Labelling, please visit our websites www.aircon.panasonic.eu or www.ptc.panasonic.eu.

## Y3 type 4 way 60x60 cassette - R32 / R410A

Mini cassette with a modern panel design is available in VRF range. **nanoe™ X (Generator Mark 3).**

The Y3 type not only perfectly matches with 600 x 600 mm ceiling grids but also provides the additional benefits of nanoe™ X, for better indoor air quality.

COMPATIBLE WITH ALL PANASONIC CONNECTIVITY SOLUTIONS. FOR DETAILED INFORMATION GO TO THE CONTROL SYSTEMS SECTION



Panel (sold separately):

**NEW! Panels.**  
White (RAL9003):  
CZ-KPY4W  
Graphite black  
(RAL9011):  
CZ-KPY4B

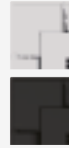

**nanoe™ X**  
nanoe™ X as a standard.

Indoor unit			S-15MY3EB	S-22MY3EB	S-28MY3EB	S-36MY3EB	S-45MY3EB	S-56MY3EB
Cooling capacity	kW		1,5	2,2	2,8	3,6	4,5	5,6
Input power	W		19,00	20,00	21,00	22,00	30,00	42,00
Current	A		0,24	0,24	0,25	0,26	0,34	0,43
Heating capacity	kW		1,7	2,5	3,2	4,2	5,0	6,3
Input power	W		17,00	18,00	19,00	20,00	28,00	40,00
Current	A		0,21	0,21	0,22	0,23	0,31	0,40
Fan type			Turbo fan	Turbo fan	Turbo fan	Turbo fan	Turbo fan	Turbo fan
nanoe X Generator			Mark 3	Mark 3	Mark 3	Mark 3	Mark 3	Mark 3
Air flow	Cool (Hi/Med/Lo)	m³/min	8,5/7,0/6,0	8,7/7,0/6,0	9,0/7,5/6,0	9,5/7,8/6,0	11,5/9,0/6,5	13,5/10,5/8,0
	Heat (Hi/Med/Lo)	m³/min	8,5/7,0/6,0	8,7/7,0/6,0	9,0/7,5/6,0	9,5/7,8/6,0	11,5/9,0/6,5	13,5/10,5/8,0
Sound pressure	Hi/Med/Lo	dB(A)	33/30/28	33/30/28	34/30/28	35/31/28	39/34/30	42/37/33
Sound power	Hi/Med/Lo	dB(A)	48/45/43	48/45/43	49/45/43	50/46/43	54/49/45	57/52/48
Dimension (HxWxD) <sup>1)</sup>	Indoor	mm	243x575x575	243x575x575	243x575x575	243x575x575	243x575x575	243x575x575
	Panel	mm	30x625x625	30x625x625	30x625x625	30x625x625	30x625x625	30x625x625
Net weight		kg	17,8(15+2,8)	17,8(15+2,8)	17,8(15+2,8)	17,8(15+2,8)	17,8(15+2,8)	17,8(15+2,8)
Piping diameter	Liquid	Inch (mm)	1/4(6,35)	1/4(6,35)	1/4(6,35)	1/4(6,35)	1/4(6,35)	1/4(6,35)
	Gas	Inch (mm)	1/2(12,70)	1/2(12,70)	1/2(12,70)	1/2(12,70)	1/2(12,70)	1/2(12,70)

1) Unit height is 230 mm, but need 243 mm height in ceiling space for its installation.

Accessories	
<b>CZ-RTC6W</b>	CONEX wired remote controller (non-wireless), white
<b>CZ-RTC6WBL</b>	CONEX wired remote controller with Bluetooth®, white
<b>CZ-RTC6WBLW2</b>	CONEX wired remote controller with Wi-Fi and Bluetooth®, white
<b>CZ-RTC6</b>	CONEX wired remote controller (non-wireless), black
<b>CZ-RTC6BL</b>	CONEX wired remote controller with Bluetooth®, black
<b>CZ-RTC6BLW2</b>	CONEX wired remote controller with Wi-Fi and Bluetooth®, black
<b>CZ-RTC5B</b>	Wired remote controller with Econavi function
<b>CZ-RWS3 + CZ-RWRY3W</b>	Infrared remote controller and receiver
<b>PAW-RE2C4-MOD-WH</b>	Room controller for hotel rooms, white

Accessories	
<b>PAW-RE2C4-MOD-BK</b>	Room controller for hotel rooms, black
<b>PAW-RE2D4-WH</b>	Display control for hotel rooms, white
<b>PAW-RE2D4-BK</b>	Display control for hotel rooms, black
<b>CZ-CENSC1</b>	Econavi energy saving sensor
<b>CZ-CGLSC2</b>	Panasonic R32 refrigerant leak detector
<b>CZ-KPY4W</b>	<b>NEW!</b> Panel for 4 way 60x60 cassette, white (RAL9003)
<b>CZ-KPY4B*</b>	<b>NEW!</b> Panel for 4 way 60x60 cassette, graphite black (RAL9011)

\*Available in Autumn 2026.

### Technical focus

- Built-in drain pump
- DC drain pump and float switch to reduce the noise
- nanoe™ X (Generator Mark 3: 48 trillion hydroxyl radicals/sec) as standard for better indoor air quality, indoor unit internal cleaning with nanoe™ X and dry operation
- **NEW!** Graphite black and white panels providing options to suit a variety of light commercial applications

### Compact and stylish design

- Required ceiling depth of only 250 mm <sup>1)</sup>
- Exposed area is only 30 mm

1) Installation dimension.

### Individual flap control

Better control of the air flow with 4 motors, providing individual flap control. Perfect air distribution without direct air flow, to reduce the feeling of cold drafts.

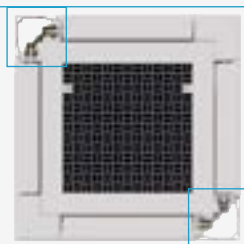

### Internal cleaning function

When cooling or dry operation stopped, internal drying and nanoe™ X circulation air flow is activated in order to suppress the mould proliferation inside the unit (air flow passage, fan, heat exchanger)\*.

\*Depending on the installation environment or operating hours, mould proliferation or inhabitation of mould growth will be changed.

After cooling/drying operation, the inside of the indoor unit is automatically dried and nanoe™ X is activated to suppress mould growth.

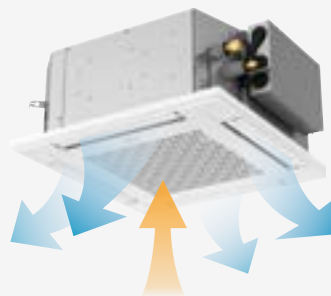

Operates the fan to discharge internal humidity.



Operate the fan to circulate nanoe™ X internally.



ECONAVI and INTERNET CONTROL: Optional.



### L1 type 2 way cassette - R410A

#### Slim, compact and lightweight units.

Remarkable size and weight reductions have been achieved by improvement of the design around the fan, the weight of all models now just 30 kg.

COMPATIBLE WITH ALL PANASONIC CONNECTIVITY SOLUTIONS. FOR DETAILED INFORMATION GO TO THE CONTROL SYSTEMS SECTION



Indoor unit			S-22ML1E5	S-28ML1E5	S-36ML1E5	S-45ML1E5	S-56ML1E5	S-73ML1E5
Cooling capacity	kW		2,2	2,8	3,6	4,5	5,6	7,3
Input power	W		90,00	92,00	93,00	97,00	97,00	145,00
Current	A		0,45	0,45	0,45	0,45	0,45	0,65
Heating capacity	kW		2,5	3,2	4,2	5,0	6,3	8,0
Input power	W		58,00	60,00	61,00	65,00	65,00	109,00
Current	A		0,29	0,29	0,29	0,29	0,29	0,48
Fan type			Sirocco fan	Sirocco fan	Sirocco fan	Sirocco fan	Sirocco fan	Sirocco fan
Air flow	Hi/Med/Lo	m <sup>3</sup> /min	8,0/7,0/6,0	9,0/8,0/7,0	9,7/8,7/7,7	11,0/9,0/8,0	11,0/9,0/8,0	19,0/16,0/14,0
Sound pressure	Hi/Med/Lo	dB(A)	30/27/24	33/29/26	34/31/28	35/33/29	35/33/29	38/35/33
Dimension (HxWxD)	Indoor	mm	350x840x600	350x840x600	350x840x600	350x840x600	350x840x600	350x1140x600
	Panel	mm	8x1060x680	8x1060x680	8x1060x680	8x1060x680	8x1060x680	8x1360x680
Net weight (Panel)		kg	26 (8)	26 (8)	26 (8)	26 (8)	26 (8)	26 (8)
Piping diameter	Liquid	Inch (mm)	1/4 (6,35)	1/4 (6,35)	1/4 (6,35)	1/4 (6,35)	1/4 (6,35)	3/8 (9,52)
	Gas	Inch (mm)	1/2 (12,70)	1/2 (12,70)	1/2 (12,70)	1/2 (12,70)	1/2 (12,70)	5/8 (15,88)

#### Accessories

<b>CZ-RTC6W</b>	CONEX wired remote controller (non-wireless), white
<b>CZ-RTC6WBL</b>	CONEX wired remote controller with Bluetooth®, white
<b>CZ-RTC6</b>	CONEX wired remote controller (non-wireless), black
<b>CZ-RTC6BL</b>	CONEX wired remote controller with Bluetooth®, black
<b>CZ-RTC5B</b>	Wired remote controller with Econavi function
<b>CZ-RWS3 + CZ-RWRL3</b>	Infrared remote controller and receiver

#### Accessories

<b>PAW-RE2C4-MOD-WH</b>	Room controller for hotel rooms, white
<b>PAW-RE2C4-MOD-BK</b>	Room controller for hotel rooms, black
<b>PAW-RE2D4-WH</b>	Display control for hotel rooms, white
<b>PAW-RE2D4-BK</b>	Display control for hotel rooms, black
<b>CZ-02KPL2</b>	Panel for S-22 to S-56 models
<b>CZ-03KPL2</b>	Panel for S-73 model

### Technical focus

- Air flow and distribution is automatically altered depending on the operational mode of the unit
- Drain pump provides up to 500 mm lift height
- Simplified maintenance

### Simplified maintenance

The drain pan is equipped with site wiring and can be removed. The fan case has a split construction, and the fan motor can be removed easily when the lower case is removed.

### Auto flap control

Air flow and distribution is automatically altered depending on the operational mode of the unit.

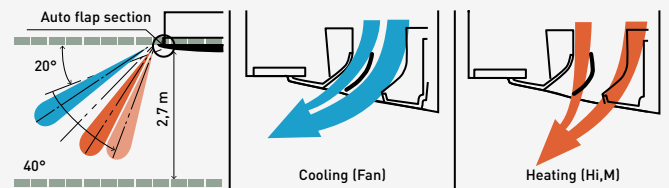

### Drain pump provides up to 500 mm lift height

Maintenance of the drain pump is possible from two sides, from the left side (piping side) and from the inside of the unit.

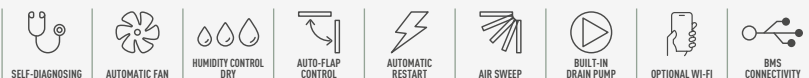
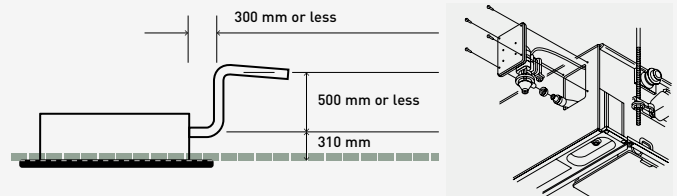

INTERNET CONTROL: Optional.

Rating conditions: Cooling indoor 27 °C DB / 19 °C WB. Cooling outdoor 35 °C DB / 24 °C WB. Heating indoor 20 °C DB. Heating outdoor 7 °C DB / 6 °C WB. (DB: Dry Bulb; WB: Wet Bulb). Specifications subject to change without notice. For detailed information about ErP / Energy Labelling, please visit our websites [www.aircon.panasonic.eu](http://www.aircon.panasonic.eu) or [www.ptc.panasonic.eu](http://www.ptc.panasonic.eu).

## D1 type 1 way cassette - R410A

Designed for installation within the ceiling void, the D1 range of slimline 1 way blow cassettes feature powerful yet quiet fans for installation of up to 4,2 m.



COMPATIBLE WITH ALL PANASONIC CONNECTIVITY SOLUTIONS. FOR DETAILED INFORMATION GO TO THE CONTROL SYSTEMS SECTION



Indoor unit			S-28MD1E5	S-36MD1E5	S-45MD1E5	S-56MD1E5	S-73MD1E5
Cooling capacity	kW		2,8	3,6	4,5	5,6	7,3
Input power	W		51,00	51,00	51,00	60,00	87,00
Current	A		0,39	0,39	0,39	0,46	0,70
Heating capacity	kW		3,2	4,2	5,0	6,3	8,0
Input power	W		40,00	40,00	40,00	48,00	76,00
Current	A		0,35	0,35	0,35	0,41	0,65
Fan type			Sirocco fan	Sirocco fan	Sirocco fan	Sirocco fan	Sirocco fan
Air flow	Hi/Med/Lo	m <sup>3</sup> /min	12,0/10,0/9,0	12,0/10,0/9,0	12,0/11,0/10,0	13,0/11,5/10,0	18,0/15,0/13,0
Sound pressure	Hi/Med/Lo	dB(A)	36/34/33	36/34/33	36/35/34	38/36/34	45/40/36
Dimension (HxWxD)	Indoor	mm	200x1000x710	200x1000x710	200x1000x710	200x1000x710	200x1000x710
	Panel	mm	20x1230x800	20x1230x800	20x1230x800	20x1230x800	20x1230x800
Net weight (Panel)		kg	23,5(7,5)	23,5(7,5)	23,5(7,5)	23,5(7,5)	24,5(7,5)
Piping diameter	Liquid	Inch (mm)	1/4 (6,35)	1/4 (6,35)	1/4 (6,35)	1/4 (6,35)	3/8 (9,52)
	Gas	Inch (mm)	1/2 (12,70)	1/2 (12,70)	1/2 (12,70)	1/2 (12,70)	5/8 (15,88)

Accessories	
<b>CZ-RTC6W</b>	CONEX wired remote controller (non-wireless), white
<b>CZ-RTC6WBL</b>	CONEX wired remote controller with Bluetooth®, white
<b>CZ-RTC6</b>	CONEX wired remote controller (non-wireless), black
<b>CZ-RTC6BL</b>	CONEX wired remote controller with Bluetooth®, black
<b>CZ-RTC5B</b>	Wired remote controller with Econavi function
<b>CZ-RWS3 + CZ-RWRD3</b>	Infrared remote controller and receiver

Accessories	
<b>PAW-RE2C4-MOD-WH</b>	Room controller for hotel rooms, white
<b>PAW-RE2C4-MOD-BK</b>	Room controller for hotel rooms, black
<b>PAW-RE2D4-WH</b>	Display control for hotel rooms, white
<b>PAW-RE2D4-BK</b>	Display control for hotel rooms, black
<b>CZ-KPD2</b>	Panel

### Technical focus

- Ultra-Slim
- Suitable for standard and high ceilings
- Built-in drain pump provides 590 mm lift
- Easy to install and maintain
- Hanging height can be easily adjusted
- Uses a DC fan motor to improve energy efficiency

### Drain height

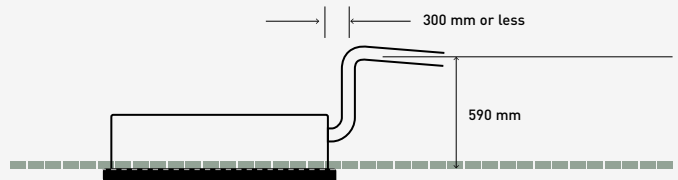

### With 2 types of air-blow systems, the units can be used in various ways



#### 1. One-direction "down-blow" system.

Powerful one-direction "down-blow" system reaches the floor even from high ceilings (up to 4,2 m).



#### 2. Two-direction ceiling-mounted system.

"Down-blow" and "front-blow" systems are combined in a ceiling-mounted unit to blow air over a wide area.

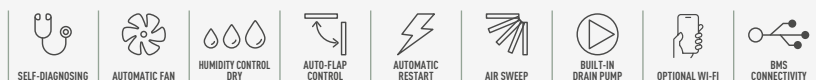

INTERNET CONTROL: Optional.



### F3 type variable static pressure adaptive duct - R32 / R410A nanoex™ X (Generator Mark 3).

2 installation possibilities (horizontal / vertical) with high ESP 150 Pa allows for flexible installation.

COMPATIBLE WITH ALL PANASONIC CONNECTIVITY SOLUTIONS. FOR DETAILED INFORMATION GO TO THE CONTROL SYSTEMS SECTION



Indoor unit. S-***MF3E5D		15	22	28	36	45	56	60	73	90	112	140	160	
Cooling capacity	kW	1,5	2,2	2,8	3,6	4,5	5,6	6,0	7,3	9,0	11,2	14,0	16,0	
Input power	W	60,00	60,00	60,00	60,00	60,00	89,00	79,00	79,00	136,00	265,00	265,00	330,00	
Current	A	0,45	0,45	0,45	0,45	0,45	0,63	0,52	0,52	0,90	1,76	1,76	2,14	
Heating capacity	kW	1,7	2,5	3,2	4,2	5,0	6,3	7,1	8,0	10,0	12,5	16,0	18,0	
Input power	W	60,00	60,00	60,00	60,00	60,00	89,00	79,00	79,00	136,00	265,00	265,00	330,00	
Current	A	0,45	0,45	0,45	0,45	0,45	0,63	0,52	0,52	0,90	1,76	1,76	2,14	
R32 leakage sensors <sup>1)</sup>		2	2	2	2	2	2	2	2	2	2	2	2	
Fan type		Sirocco fan	Sirocco fan	Sirocco fan	Sirocco fan	Sirocco fan	Sirocco fan	Sirocco fan	Sirocco fan	Sirocco fan	Sirocco fan	Sirocco fan	Sirocco fan	
nanoex X Generator		Mark 3	Mark 3	Mark 3	Mark 3	Mark 3	Mark 3	Mark 3	Mark 3	Mark 3	Mark 3	Mark 3	Mark 3	
External static pressure	Pa	30 (10-150)	30 (10-150)	30 (10-150)	30 (10-150)	30 (10-150)	30 (10-150)	30 (10-150)	30 (10-150)	40 (10-150)	50 (10-150)	50 (10-150)	50 (10-150)	
Air flow <sup>2)</sup>	Hi/ Med/ Lo	m <sup>3</sup> /min	12,8/11,0/ 8,0	12,8/11,0/ 8,0	12,8/11,0/ 8,0	14,0/12,0/ 8,0	14,0/12,0/ 8,0	16,0/14,0/ 10,0	21,0/18,0/ 15,0	21,0/18,0/ 15,0	25,0/23,0/ 16,0	37,0/32,0/ 26,0	37,0/32,0/ 26,0	40,0/34,0/ 28,0
Sound pressure		dB(A)	31/28/20	31/28/20	31/28/20	31/28/20	31/28/20	35/32/24	31/28/23	31/28/23	35/33/25	41/36/32	41/36/32	43/37/33
Sound power		dB(A)	54/51/43	54/51/43	54/51/43	54/51/43	54/51/43	58/55/47	54/51/46	54/51/46	58/56/48	64/59/55	64/59/55	66/60/56
Dimension (H x W x D)		mm	250 x 800 x 730	250 x 800 x 730	250 x 800 x 730	250 x 800 x 730	250 x 800 x 730	250 x 800 x 730	250 x 1000 x 730	250 x 1000 x 730	250 x 1000 x 730	250 x 1400 x 730	250 x 1400 x 730	
Net weight		kg	26	26	26	26	26	26	31	31	31	40	40	
Piping diameter	Liquid	Inch (mm)	1/4(6,35)	1/4(6,35)	1/4(6,35)	1/4(6,35)	1/4(6,35)	1/4(6,35)	1/4(6,35)	1/4(6,35)	1/4(6,35)	3/8(9,52)	3/8(9,52)	3/8(9,52)
R32 model	Gas	Inch (mm)	1/2(12,70)	1/2(12,70)	1/2(12,70)	1/2(12,70)	1/2(12,70)	1/2(12,70)	1/2(12,70)	1/2(12,70)	1/2(12,70)	5/8(15,88)	5/8(15,88)	5/8(15,88)
Piping diameter	Liquid	Inch (mm)	1/4(6,35)	1/4(6,35)	1/4(6,35)	1/4(6,35)	1/4(6,35)	1/4(6,35)	3/8(9,52)	3/8(9,52)	3/8(9,52)	3/8(9,52)	3/8(9,52)	3/8(9,52)
R410A model	Gas	Inch (mm)	1/2(12,70)	1/2(12,70)	1/2(12,70)	1/2(12,70)	1/2(12,70)	1/2(12,70)	5/8(15,88)	5/8(15,88)	5/8(15,88)	5/8(15,88)	5/8(15,88)	

1) Only available in the R32 version. 2) Value referred to standard settings at shipment (H curve 8, M curve 5, L curve 1).

#### Accessories

<b>CZ-RTC6W</b>	CONEX wired remote controller (non-wireless), white
<b>CZ-RTC6WBL</b>	CONEX wired remote controller with Bluetooth®, white
<b>CZ-RTC6WBLW2</b>	CONEX wired remote controller with Wi-Fi and Bluetooth®, white
<b>CZ-RTC6</b>	CONEX wired remote controller (non-wireless), black
<b>CZ-RTC6BL</b>	CONEX wired remote controller with Bluetooth®, black
<b>CZ-RTC6BLW2</b>	CONEX wired remote controller with Wi-Fi and Bluetooth®, black
<b>CZ-RTC5B</b>	Wired remote controller with Econavi function
<b>CZ-RWS3 + CZ-RWRC3</b>	Infrared remote controller and receiver
<b>PAW-RE2C4-MOD-WH</b>	Room controller for hotel rooms, white

#### Accessories

<b>PAW-RE2C4-MOD-BK</b>	Room controller for hotel rooms, black
<b>PAW-RE2D4-WH</b>	Display control for hotel rooms, white
<b>PAW-RE2D4-BK</b>	Display control for hotel rooms, black
<b>CZ-CENSC1</b>	Econavi energy saving sensor
<b>PAW-APF800F</b>	BION air pollutant filter for MF3 15, 22, 28, 36, 45 and 56
<b>PAW-APF1000F</b>	BION air pollutant filter for MF3 60 and 73
<b>PAW-APF1400F</b>	BION air pollutant filter for MF3 90, 112, 140 and 160
<b>CZ-CGLALC1</b>	R32 refrigerant leak alarm

## Technical focus

- 4 installation possibilities with horizontal and vertical mounting, plus selectable rear or bottom air inlet
- Industry leading low noise with super quiet operation, minimum 20 dB(A)
- Only 250 mm height and lightweight unit from, 26 to 40 kg
- Integrated Panasonic R32 refrigerant leak detectors <sup>1)</sup>
- Improved drain pan suitable for both horizontal / vertical installation
- Drain pump included <sup>2)</sup>
- nanoex™ X (Generator Mark 3: 48 trillion hydroxyl radicals/sec) as standard, effective even with duct connections up to 10 m with 3 x 90° bends <sup>3)</sup>
- BION air pollutant filter for certain types of pollutants, such as nitrogen dioxide (NO<sub>2</sub>), nitrogen oxides (NO<sub>x</sub>) and Ozone (O<sub>3</sub>) (optional)

1) Only available in the R32 version. 2) For use with horizontal installation only. 3) Panasonic internal survey.

## Vertical Installation

Vertical installation option. Variable external static pressure to support ducted installations with bends.

\* Vertical installation requires additional settings on field, please check the installation manual.



## Improved drain pan design

Drain pan is shared in both cases horizontal and vertical installation. No need to modify the unit.

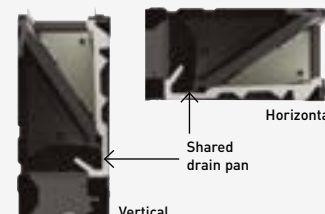

ECONAVI and INTERNET CONTROL: Optional.

Rating conditions: Cooling indoor 27 °C DB / 19 °C WB. Cooling outdoor 35 °C DB / 24 °C WB. Heating indoor 20 °C DB. Heating outdoor 7 °C DB / 6 °C WB. (DB: Dry Bulb, WB: Wet Bulb). Specifications subject to change without notice. For detailed information about ErP / Energy Labelling, please visit our websites [www.aircon.panasonic.eu](http://www.aircon.panasonic.eu) or [www.ptc.panasonic.eu](http://www.ptc.panasonic.eu).

## M2 type slim variable static pressure hide-away concealed duct - R32 / R410A

### nanoe™ X (Generator Mark 3).

Ultra-slim profile: 200 mm for all capacities.

Ideal for hotel application with very narrow false ceilings.



COMPATIBLE WITH ALL PANASONIC CONNECTIVITY SOLUTIONS. FOR DETAILED INFORMATION GO TO THE CONTROL SYSTEMS SECTION



**nanoe™ X**  
nanoe™ X as a standard.

Indoor unit			S-10MM2EB	S-15MM2EB	S-22MM2EB	S-28MM2EB	S-36MM2EB	S-45MM2EB	S-56MM2EB
Cooling capacity	kW		1,0	1,5	2,2	2,8	3,6	4,5	5,6
Input power	W		12,00	19,00	25,00	29,00	32,00	39,00	54,00
Current	A		0,25	0,30	0,33	0,35	0,36	0,44	0,51
Heating capacity	kW		1,3	1,7	2,5	3,2	4,2	5,0	6,3
Input power	W		12,00	19,00	25,00	29,00	32,00	39,00	54,00
Current	A		0,25	0,30	0,33	0,35	0,36	0,44	0,51
Fan type			Sirocco fan	Sirocco fan	Sirocco fan	Sirocco fan	Sirocco fan	Sirocco fan	Sirocco fan
nanoe X Generator			Mark 3	Mark 3	Mark 3	Mark 3	Mark 3	Mark 3	Mark 3
Air flow	Hi/Med/Lo	m <sup>3</sup> /min	4,5/4,3/4,1	6,8/6,2/5,0	8,0/7,0/5,0	8,5/7,5/6,5	9,0/8,0/7,0	13,0/11,0/10,5	15,0/13,0/11,0
External static pressure		Pa	10(30)	10(30)	10(30)	15(30)	15(40)	15(40)	15(40)
Sound pressure	Hi/Med/Lo <sup>1)</sup>	dB(A)	22/21/20	24/23/20	26/25/20	27/26/23	28/26/23	30/27/26	32/29/27
Sound power	Hi/Med/Lo	dB(A)	37/36/35	39/38/35	41/40/35	42/41/38	43/41/38	45/42/41	47/44/42
Dimension	H x W x D	mm	200 x 700 x 450	200 x 700 x 450	200 x 700 x 450	200 x 700 x 450	200 x 700 x 450	200 x 900 x 450	200 x 900 x 450
Net weight		kg	17	17	17	17	17	19	19
Piping diameter	Liquid	Inch (mm)	1/4(6,35)	1/4(6,35)	1/4(6,35)	1/4(6,35)	1/4(6,35)	1/4(6,35)	1/4(6,35)
	Gas	Inch (mm)	1/2(12,70)	1/2(12,70)	1/2(12,70)	1/2(12,70)	1/2(12,70)	1/2(12,70)	1/2(12,70)

1) By DIP switches or by RC setting.

#### Accessories

<b>CZ-RTC6W</b>	CONEX wired remote controller (non-wireless), white
<b>CZ-RTC6WBL</b>	CONEX wired remote controller with Bluetooth®, white
<b>CZ-RTC6WBLW2</b>	CONEX wired remote controller with Wi-Fi and Bluetooth®, white
<b>CZ-RTC6</b>	CONEX wired remote controller (non-wireless), black
<b>CZ-RTC6BL</b>	CONEX wired remote controller with Bluetooth®, black
<b>CZ-RTC6BLW2</b>	CONEX wired remote controller with Wi-Fi and Bluetooth®, black
<b>CZ-RTC5B</b>	Wired remote controller with Econavi function

#### Accessories

<b>CZ-RWS3 + CZ-RWRC3</b>	Infrared remote controller and receiver
<b>PAW-RE2C4-MOD-WH</b>	Room controller for hotel rooms, white
<b>PAW-RE2C4-MOD-BK</b>	Room controller for hotel rooms, black
<b>PAW-RE2D4-WH</b>	Display control for hotel rooms, white
<b>PAW-RE2D4-BK</b>	Display control for hotel rooms, black
<b>CZ-CENSC1</b>	Econavi energy saving sensor
<b>CZ-CGLALC1</b>	R32 refrigerant leak alarm

### Technical focus

- Ultra-slim profile: 200 mm for all models
- DC fan motor greatly reduces power consumption
- Ideal for hotel application with very narrow false ceilings
- Easy maintenance and service by external electrical box
- Up to 40 Pa static pressure enables ductwork to be fitted
- Includes drain pump
- nanoe™ X (Generator Mark 3: 48 trillion hydroxyl radicals/sec) as standard for better indoor air quality

### Ultra-slim profile for all models

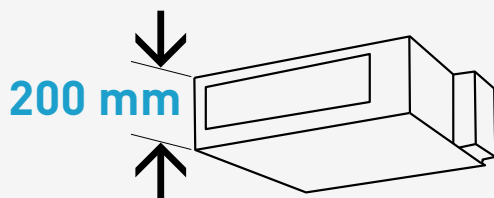

In addition, its high-efficiency and extremely quiet sound levels make it very popular with many users, including hotels and small offices.

### Drain pump with increased power!

By adoption of a high-lift drain pump, the drain piping can achieve up to 500 mm lift from the outlet port of the unit.

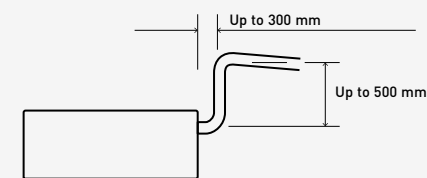

ECONAVI and INTERNET CONTROL: Optional.



## E2 type high static pressure hide-away - R410A

### High pressure duct and 100% fresh air duct function.

The E2 range of ducted units offers improved design flexibility for extended duct layouts as a result of their increased external static pressures whilst reducing energy consumption.

COMPATIBLE WITH ALL PANASONIC CONNECTIVITY SOLUTIONS. FOR DETAILED INFORMATION GO TO THE CONTROL SYSTEMS SECTION



Type	100% fresh air duct function (by using kit for 100% fresh air)				High pressure duct							
	S-224ME2E5		S-280ME2E5		S-224ME2E5		S-280ME2E5					
Indoor unit	Cooling	Heating	Cooling	Heating	Cooling	Heating	Cooling	Heating				
Capacity	kW	22,4	21,2	28,0	26,5	22,4	25,0	28,0	31,5			
Input power	W	290,00	290,00	350,00	350,00	440,00	440,00	715,00	715,00			
Current	A	1,85	1,85	2,20	2,20	2,45	2,45	3,95	3,95			
Air flow	Hi/Med/Lo	m <sup>3</sup> /min		28,3/-/-		35,0/-/-		56,0/51,0/44,0		72,0/63,0/53,0		
External static pressure	Pa	200		200		140(60-270) <sup>1)</sup>		140(72-270) <sup>1)</sup>				
Sound pressure <sup>2)</sup>	Hi/Med/Lo	dB(A)		43/-/-		44/-/-		45/43/41		49/47/43		
Sound power	Hi/Med/Lo	dB(A)		75/-/-		76/-/-		77/75/73		81/79/75		
Dimension	H x W x D	mm		479 x 1453 x 1205		479 x 1453 x 1205		479 x 1453 x 1205		479 x 1453 x 1205		
Net weight	kg	102		106		102		106				
Piping diameter	Liquid	Inch (mm)	3/8(9,52)		3/8(9,52)		3/8(9,52)		3/8(9,52)			
	Gas	Inch (mm)	3/4(19,05)		7/8(22,22)		3/4(19,05)		7/8(22,22)			

Rating conditions for 100% fresh air duct function: Cooling outdoor 33 °C DB / 28 °C WB. Heating outdoor 0 °C DB / -2,9 °C WB.

1) Available to select the setting by initial setup. 2) Values with 140 Pa setting. \*No filter included.

### Accessories

<b>CZ-RTC6W</b>	CONEX wired remote controller (non-wireless), white
<b>CZ-RTC6WBL</b>	CONEX wired remote controller with Bluetooth®, white
<b>CZ-RTC6</b>	CONEX wired remote controller (non-wireless), black
<b>CZ-RTC6BL</b>	CONEX wired remote controller with Bluetooth®, black
<b>CZ-RTC5B</b>	Wired remote controller with Econavi function
<b>CZ-RWS3 + CZ-RWRC3</b>	Infrared remote controller and receiver

### Accessories

<b>PAW-RE2C4-MOD-WH</b>	Room controller for hotel rooms, white
<b>PAW-RE2C4-MOD-BK</b>	Room controller for hotel rooms, black
<b>PAW-RE2D4-WH</b>	Display control for hotel rooms, white
<b>PAW-RE2D4-BK</b>	Display control for hotel rooms, black
<b>CZ-CENSC1</b>	Econavi energy saving sensor

## Technical focus

- No need of rap valves for standard operation
- 100% fresh air duct function\*
- DC fan motor for more savings
- Complete flexibility for ductwork design
- Can be located within a weatherproof housing for external installation
- Air OFF sensor avoids cold air dumping
- Configurable air temperature control

\*Rap valves required, see 100% fresh air duct function below.

## 100% fresh air duct function

The E2 duct with 100% fresh air duct function have exceptional discharge temperature.

	Discharge Range		
	Min	Max	Default
Cooling	15 °C	24 °C	18 °C
Heating	17 °C	45 °C	40 °C

## System example

An inspection port (450 x 450 mm or more) is required at the lower side of the indoor unit body (field supply).

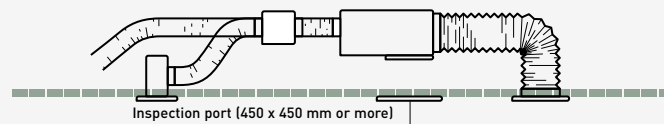

## Plenums

Air outlet plenum (suitable for rigid + flexible duct)		
	Number of exits with diameters	Model
S-224ME2E5	1 x 500 mm	CZ-TREMIESPW705
S-280ME2E5	1 x 500 mm	CZ-TREMIESPW706

## Kit for 100% fresh air function

Kit for 2 way systems		Kit for 3 way systems	
<b>2x CZ-P160RVK2</b>	Rap valve kit	<b>2x CZ-P160HR3</b>	3 way valve kit
<b>2x CZ-CAPE2</b>	3 way control PCB	<b>2x CZ-CAPE2</b>	3 way control PCB
<b>CZ-P680BK2BM</b>	Distribution joint kit	<b>CZ-P680BH2BM</b>	Distribution joint kit
	1x remote controller		1x remote controller



ECONAVI and INTERNET CONTROL: Optional.

Rating conditions: Cooling indoor 27 °C DB / 19 °C WB. Cooling outdoor 35 °C DB / 24 °C WB. Heating indoor 20 °C DB. Heating outdoor 7 °C DB / 6 °C WB. (DB: Dry Bulb; WB: Wet Bulb). Specifications subject to change without notice. For detailed information about ErP / Energy Labelling, please visit our websites www.aircon.panasonic.eu or www.ptc.panasonic.eu.

## Wall-mounted with nanoe X Generator Mark 3

The K3 wall-mounted unit features the upgraded nanoe™ X (Generator Mark 3).



Modern design for any interior. Its modern, flat design with a stylish matte white finish suits any interior, perfect for commercial projects.

**Air distribution is automatically altered depending on the operational mode of the unit**

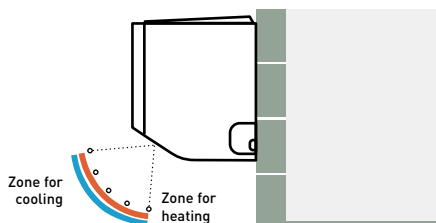

**Piping outlet in six directions**

Piping outlet is possible in six directions of; right, right rear, right bottom, left, left rear and left bottom, making the installation work more flexible.

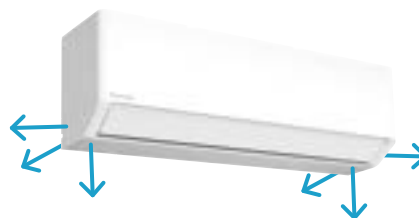

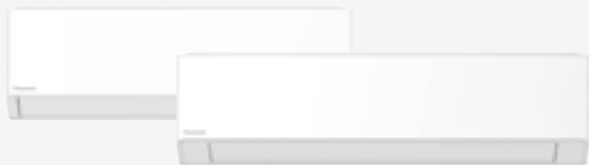

### K3 type wall-mounted - R32 / R410A

#### nanoe™ X (Generator Mark 3).

It's modern, flat design with a stylish matte white finish complements any interior, while improved fan serviceability ensures effortless maintenance.

COMPATIBLE WITH ALL PANASONIC CONNECTIVITY SOLUTIONS. FOR DETAILED INFORMATION GO TO THE CONTROL SYSTEMS SECTION



Indoor unit			S-15MK3E	S-22MK3E	S-28MK3E	S-36MK3E	S-45MK3E	S-56MK3E	S-73MK3E	S-106MK3E
Cooling capacity	kW		1,5	2,2	2,8	3,6	4,5	5,6	7,3	10,6
Input power	W		15,00	18,00	19,00	20,00	25,00	40,00	55,00	80,00
Current	A		0,18	0,19	0,20	0,22	0,25	0,35	0,50	0,70
Heating capacity	kW		1,7	2,5	3,2	4,2	5,0	6,3	8,0	10,6
Input power	W		15,00	18,00	19,00	20,00	25,00	40,00	55,00	80,00
Current	A		0,18	0,19	0,20	0,22	0,25	0,35	0,50	0,70
Fan type			Cross flow	Cross flow	Cross flow	Cross flow	Cross flow	Cross flow	Cross flow	Cross flow
nanoe X Generator			Mark 3	Mark 3	Mark 3	Mark 3	Mark 3	Mark 3	Mark 3	Mark 3
Air flow	Cool (Hi/Med/Lo)	m <sup>3</sup> /min	6,8/6,3/5,5	9,0/8,0/7,0	9,5/8,5/7,0	10,5/9,0/7,5	11,5/10,0/7,5	15,0/14,0/13,0	19,0/17,0/14,0	22,0/18,0/14,0
	Heat (Hi/Med/Lo)	m <sup>3</sup> /min	6,8/6,3/5,5	9,0/8,0/7,0	10,0/8,5/7,0	10,5/9,0/7,5	11,5/10,0/7,5	15,0/14,0/13,0	19,0/17,0/14,0	22,0/18,0/14,0
Sound pressure	Hi/Med/Lo	dB(A)	31/29/28	32/30/29	33/31/29	35/32/29	38/33/29	40/38/35	47/44/40	50/45/40
Sound power	Hi/Med/Lo	dB(A)	46/44/43	47/45/44	48/46/44	50/47/44	53/48/44	55/53/50	62/59/55	65/60/55
Dimension	H x W x D	mm	295 x 890 x 244	295 x 890 x 244	295 x 890 x 244	295 x 890 x 244	295 x 890 x 244	295 x 1060 x 249	295 x 1060 x 249	295 x 1060 x 249
Net weight		kg	12	12	12	12	12	14	14	14
Piping diameter	Liquid	Inch (mm)	1/4(6,35)	1/4(6,35)	1/4(6,35)	1/4(6,35)	1/4(6,35)	1/4(6,35)	3/8(9,52) <sup>1)</sup>	3/8(9,52)
	Gas	Inch (mm)	1/2(12,70)	1/2(12,70)	1/2(12,70)	1/2(12,70)	1/2(12,70)	1/2(12,70)	5/8(15,88) <sup>1)</sup>	5/8(15,88)

1) When the piping diameter is (liquid) Ø1/4 (6,35) - (gas) Ø1/2 (12,70), connect the liquid socket tube (Ø1/4 (6,35) - Ø3/8 (9,52)) to the liquid tubing side indoor unit and connect the gas socket tube (Ø1/2 (12,70) - Ø5/8 (15,88)) to the gas tubing side indoor unit.

#### Accessories

<b>CZ-RTC6W</b>	CONEX wired remote controller (non-wireless), white
<b>CZ-RTC6WBL</b>	CONEX wired remote controller with Bluetooth®, white
<b>CZ-RTC6WBLW2</b>	CONEX wired remote controller with Wi-Fi and Bluetooth®, white
<b>CZ-RTC6</b>	CONEX wired remote controller (non-wireless), black
<b>CZ-RTC6BL</b>	CONEX wired remote controller with Bluetooth®, black
<b>CZ-RTC6BLW2</b>	CONEX wired remote controller with Wi-Fi and Bluetooth®, black
<b>CZ-RTC5B</b>	Wired remote controller with Econavi function
<b>CZ-RWS3</b>	Infrared remote controller

#### Accessories

<b>PAW-RE2C4-MOD-WH</b>	Room controller for hotel rooms, white
<b>PAW-RE2C4-MOD-BK</b>	Room controller for hotel rooms, black
<b>PAW-RE2D4-WH</b>	Display control for hotel rooms, white
<b>PAW-RE2D4-BK</b>	Display control for hotel rooms, black
<b>CZ-CENSC1</b>	Econavi energy saving sensor
<b>CZ-P73SVK3</b>	External valve for model sizes 15 to 73*
<b>CZ-P106SVK3</b>	External valve for model size 106
<b>CZ-CGLSC2</b>	Panasonic R32 refrigerant leak detector

\*A 3/8" to 1/4" reducer is required when combining the S-73MK3E with ECOi EX R410A outdoor units (ME2 and MF3).

### Technical focus

- Modern, flat design with a stylish matte white finish
- Quiet operation
- nanoe™ X (Generator Mark 3: 48 trillion hydroxyl radicals/sec) as standard
- Easy fan, front grill, and blow-off grill removal for easy maintenance
- Efficient installation with drain hose support holders and lock mechanism
- Piping outlet in six directions
- Air distribution is automatically altered depending on the operational mode

### External valve (optional)

CZ-P73SVK3 (model sizes 15 to 73\*).  
CZ-P106SVK3 (model size 106).

\*A 3/8" to 1/4" reducer is required when combining the S-73MK3E with ECOi EX R410A outdoor units (ME2 and MF3).



### Efficient installation with drain hose support holders and lock mechanism

**Easy connection and disconnection of the drain hose.**  
Locking mechanism between the drain tray and hose ensures a tight connection during installation and easy dismantling.



**Built-in support holders for secure spacing.**  
Holds the indoor unit against the wall, providing clear access for setting up the drain hose and piping.



ECONAVI and INTERNET CONTROL: Optional.

Rating conditions: Cooling indoor 27 °C DB / 19 °C WB. Cooling outdoor 35 °C DB / 24 °C WB. Heating indoor 20 °C DB. Heating outdoor 7 °C DB / 6 °C WB. (DB: Dry Bulb; WB: Wet Bulb). Specifications subject to change without notice. For detailed information about ErP / Energy Labelling, please visit our websites [www.aircon.panasonic.eu](http://www.aircon.panasonic.eu) or [www.ptc.panasonic.eu](http://www.ptc.panasonic.eu).

## T2 type ceiling - R410A

The T2 type ceiling mounted units feature a DC fan motor for increased efficiency and reduced operating sound levels.

All the units are the same height and depth for a uniform appearance in mixed installations, and feature a fresh air knockout for improved air quality.



COMPATIBLE WITH ALL PANASONIC CONNECTIVITY SOLUTIONS. FOR DETAILED INFORMATION GO TO THE CONTROL SYSTEMS SECTION



Indoor unit			S-36MT2E5A	S-45MT2E5A	S-56MT2E5A	S-73MT2E5A	S-106MT2E5A	S-140MT2E5A
Cooling capacity	kW		3,6	4,5	5,6	7,3	10,6	14,0
Input power	W		35,00	40,00	40,00	55,00	80,00	100,00
Current	A		0,36	0,38	0,38	0,44	0,67	0,79
Heating capacity	kW		4,2	5,0	6,3	8,0	11,4	16,0
Input power	W		35,00	40,00	40,00	55,00	80,00	100,00
Current	A		0,36	0,38	0,38	0,44	0,67	0,79
Fan type			Sirocco fan	Sirocco fan	Sirocco fan	Sirocco fan	Sirocco fan	Sirocco fan
Air flow	Hi/Med/Lo	m <sup>3</sup> /min	14,0/12,0/10,5	15,0/12,5/10,5	15,0/12,5/10,5	21,0/18,0/15,5	30,0/25,0/23,0	32,0/28,0/24,0
Sound pressure	Hi/Med/Lo	dB(A)	36/32/30	37/33/30	37/33/30	39/35/33	42/37/36	46/40/37
Sound power	Hi/Med/Lo	dB(A)	54/50/48	55/51/48	55/51/48	57/53/51	60/55/54	62/58/55
Dimension	HxWxD	mm	235x960x690	235x960x690	235x960x690	235x1275x690	235x1590x690	235x1590x690
Net weight		kg	27	27	27	33	40	40
Piping diameter	Liquid	Inch (mm)	1/4 (6,35)	1/4 (6,35)	1/4 (6,35)	3/8 (9,52)	3/8 (9,52)	3/8 (9,52)
	Gas	Inch (mm)	1/2 (12,70)	1/2 (12,70)	1/2 (12,70)	5/8 (15,88)	5/8 (15,88)	5/8 (15,88)

Accessories	
<b>CZ-RTC6W</b>	CONEX wired remote controller (non-wireless), white
<b>CZ-RTC6WBL</b>	CONEX wired remote controller with Bluetooth®, white
<b>CZ-RTC6</b>	CONEX wired remote controller (non-wireless), black
<b>CZ-RTC6BL</b>	CONEX wired remote controller with Bluetooth®, black
<b>CZ-RTC5B</b>	Wired remote controller with Econavi function
<b>CZ-RWS3 + CZ-RWRT3</b>	Infrared remote controller and receiver

Accessories	
<b>PAW-RE2C4-MOD-WH</b>	Room controller for hotel rooms, white
<b>PAW-RE2C4-MOD-BK</b>	Room controller for hotel rooms, black
<b>PAW-RE2D4-WH</b>	Display control for hotel rooms, white
<b>PAW-RE2D4-BK</b>	Display control for hotel rooms, black
<b>CZ-CENSC1</b>	Econavi energy saving sensor

### Technical focus

- Low sound levels
- All units just 235 mm high
- Large and wide air distribution
- Easy to install and maintain
- Fresh air knockout

### Air distribution is altered depending on the operational mode

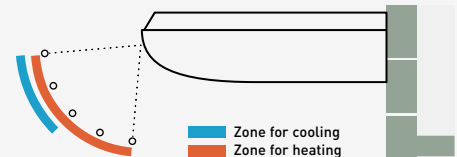

### Further comfort improvement with air flow distribution

Horizontal air flow reaches maximum 9,5 m. This is ideal for wide rooms.

The wide air discharge opening expands the air flow to the left and right. The unpleasant feeling caused when the air flow directly hits the human body is prevented by the "Draft prevention position", which changes the swing width, increasing the degree of comfort.

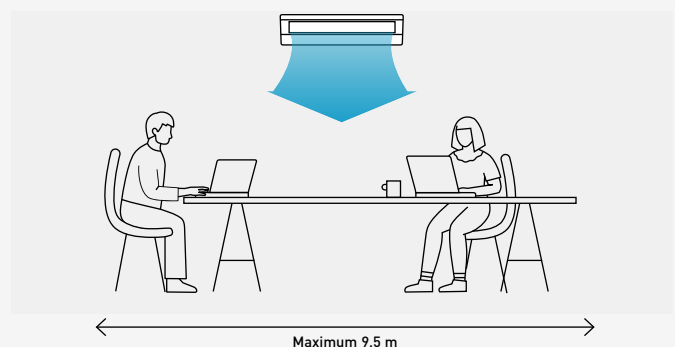

ECONAVI and INTERNET CONTROL: Optional.



### G1 type floor console - R410A

The stylish and compact unit profile, also used for residential market range, is easy to integrate into any design of building.

Compact and versatile, this system is capable of being installed in an area with limited space. It is a perfect solution for retrofit, replacing existing radiator panels.

COMPATIBLE WITH ALL PANASONIC CONNECTIVITY SOLUTIONS. FOR DETAILED INFORMATION GO TO THE CONTROL SYSTEMS SECTION



Indoor unit			S-22MG1E5N	S-28MG1E5N	S-36MG1E5N	S-45MG1E5N	S-56MG1E5N
Cooling capacity	kW		2,2	2,8	3,6	4,5	5,6
Input power	W		20,00	20,00	22,00	28,00	31,00
Current	A		0,20	0,20	0,23	0,25	0,28
Heating capacity	kW		2,5	3,2	4,2	5,0	6,3
Input power	W		21,00	21,00	23,00	29,00	32,00
Current	A		0,20	0,20	0,24	0,26	0,28
Fan type			Cross flow	Cross flow	Cross flow	Cross flow	Cross flow
nanoe X Generator			Mark 1	Mark 1	Mark 1	Mark 1	Mark 1
Air flow	Cool (Hi/Med/Lo)	m <sup>3</sup> /min	9,2/7,5/6,0	9,2/7,5/6,0	9,7/8,2/6,0	10,5/9,0/6,5	12,0/9,5/6,5
	Heat (Hi/Med/Lo)	m <sup>3</sup> /min	9,7/8,0/6,5	9,7/8,0/6,5	10,2/8,7/6,5	11,0/9,5/7,0	12,5/10,0/7,0
Sound pressure	Hi/Med/Lo	dB(A)	38/34/29	38/34/29	39/35/29	42/37/30	44/38/30
Dimension	H x W x D	mm	600 x 750 x 207	600 x 750 x 207	600 x 750 x 207	600 x 750 x 207	600 x 750 x 207
Net weight		kg	14	14	14	14	14
Piping diameter	Liquid	Inch (mm)	1/4(6,35)	1/4(6,35)	1/4(6,35)	1/4(6,35)	1/4(6,35)
	Gas	Inch (mm)	1/2(12,70)	1/2(12,70)	1/2(12,70)	1/2(12,70)	1/2(12,70)

\*Infrared receiver is integrated with the unit as standard.

#### Accessories

<b>CZ-RTC6W</b>	CONEX wired remote controller (non-wireless), white
<b>CZ-RTC6WBL</b>	CONEX wired remote controller with Bluetooth®, white
<b>CZ-RTC6</b>	CONEX wired remote controller (non-wireless), black
<b>CZ-RTC6BL</b>	CONEX wired remote controller with Bluetooth®, black
<b>CZ-RTC5B</b>	Wired remote controller with Econavi function
<b>CZ-RWS3*</b>	Infrared remote controller

#### Accessories

<b>PAW-RE2C4-MOD-WH</b>	Room controller for hotel rooms, white
<b>PAW-RE2C4-MOD-BK</b>	Room controller for hotel rooms, black
<b>PAW-RE2D4-WH</b>	Display control for hotel rooms, white
<b>PAW-RE2D4-BK</b>	Display control for hotel rooms, black
<b>CZ-CENSC1</b>	Econavi energy saving sensor

## 1 nanoe™ X: Bringing nature's balance indoors

Panasonic's nanoe™ X technology brings nature's detergent – hydroxyl radicals – indoors to help improve protection 24/7 against several types of pollutants can be inhibited such as certain types of bacteria, viruses, mould, allergens, pollen or hazardous substances.

## 2 Stylish and simple

- Clean and modern European design with slim depth
- Modern matt white color panel
- Washable air filter

The stylish and compact unit profile, also used for residential market range, is easy to integrate into any design of building.



**Dimension:**  
W x H x D = 750 x 600 x 207 mm

**Weight:**  
14kg

## 3 Flexible easy installation

Four different mounting styles possible: exposed (floor or wall), semi-recessed and recessed.

Flexible installation with 4 different options.

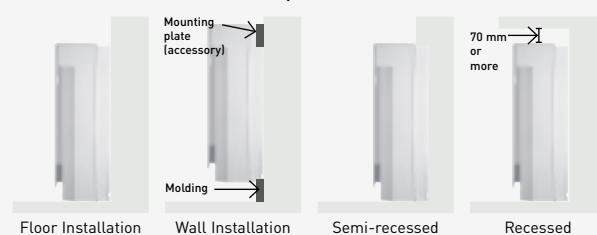

## 4 Functions for comfort

- Double Air Flow direction to maximize comfort
- Self-cleaning function
- Compatible with Commercial Wi-Fi Adaptor for cloud control

### Self-cleaning function.

- Self cleaning function can be pre-scheduled with remote controller, up to a maximum of 90 minutes following cooling / dry operation
- Air flow will not blow directly at occupants during self-cleaning



ECONAVI and INTERNET CONTROL: Optional.

Rating conditions: Cooling indoor 27 °C DB / 19 °C WB. Cooling outdoor 35 °C DB / 24 °C WB. Heating indoor 20 °C DB. Heating outdoor 7 °C DB / 6 °C WB. (DB: Dry Bulb; WB: Wet Bulb). Specifications subject to change without notice. For detailed information about ErP / Energy Labelling, please visit our websites [www.aircon.panasonic.eu](http://www.aircon.panasonic.eu) or [www.ptc.panasonic.eu](http://www.ptc.panasonic.eu).

**NEW! P2 type floor-standing - R32 / R410A****NEW! R2 type concealed floor-standing - R32 / R410A**

Optimised for efficiency and lower costs, with nanoe™ X for better air quality. Slim design (P1: 210 mm, R2: 200 mm) fits perimeter spaces, delivering powerful heating and cooling without compromising aesthetics.

**COMPATIBLE WITH ALL PANASONIC CONNECTIVITY SOLUTIONS. FOR DETAILED INFORMATION GO TO THE CONTROL SYSTEMS SECTION**



NEW

  
nanoe™ X as a standard.

P2 indoor unit		S-22MP2E	S-28MP2E	S-36MP2E	S-45MP2E	S-56MP2E	S-71MP2E	
R2 indoor unit		S-22MR2E	S-28MR2E	S-36MR2E	S-45MR2E	S-56MR2E	S-71MR2E	
Cooling capacity	kW	2,2	2,8	3,6	4,5	5,6	7,1	
Input power	W	24,00	24,00	40,00	44,00	49,00	57,00	
Current	A	0,31	0,31	0,40	0,46	0,51	0,56	
Heating capacity	kW	2,5	3,2	4,2	5,0	6,3	8,0	
Input power	W	26,00	26,00	42,00	51,00	56,00	64,00	
Current	A	0,35	0,35	0,44	0,52	0,57	0,62	
Fan type		Sirocco fan	Sirocco fan	Sirocco fan	Sirocco fan	Sirocco fan	Sirocco fan	
nanoe X Generator		Mark 3	Mark 3	Mark 3	Mark 3	Mark 3	Mark 3	
Air flow	Hi/Med/Lo	m <sup>3</sup> /min	7,0/6,0/5,0	7,0/6,0/5,0	9,0/7,0/6,0	14,5/12,5/11,0	15,0/13,0/11,0	16,0/14,0/12,0
External static pressure		Pa	15	15	15	15	15	
Sound pressure	Hi/Med/Lo	dB(A)	33/30/28	33/30/28	39/35/29	38/35/31	39/36/31	40/38/35
P2 dimension	HxWxD	mm	615x1060x210	615x1060x210	615x1060x210	615x1460x210	615x1460x210	615x1460x210
P2 net weight		kg	29	29	29	38	38	38
R2 dimension	HxWxD	mm	595x1060x200	595x1060x200	595x1060x200	595x1460x200	595x1460x200	595x1460x200
R2 net weight		kg	21	21	21	28	28	28
Piping diameter	Liquid	Inch (mm)	1/4(6,35)	1/4(6,35)	1/4(6,35)	1/4(6,35)	1/4(6,35)	3/8(9,52)
	Gas	Inch (mm)	1/2(12,70)	1/2(12,70)	1/2(12,70)	1/2(12,70)	1/2(12,70)	5/8(15,88)

**Accessories**

<b>CZ-RTC6W</b>	CONEX wired remote controller (non-wireless), white
<b>CZ-RTC6WBL</b>	CONEX wired remote controller with Bluetooth®, white
<b>CZ-RTC6</b>	CONEX wired remote controller (non-wireless), black
<b>CZ-RTC6BL</b>	CONEX wired remote controller with Bluetooth®, black
<b>CZ-RTC5B</b>	Wired remote controller with Econavi function

**Accessories**

<b>CZ-RWS3 + CZ-RWRC3</b>	Infrared remote controller and receiver
<b>PAW-RE2C4-MOD-WH</b>	Room controller for hotel rooms, white
<b>PAW-RE2C4-MOD-BK</b>	Room controller for hotel rooms, black
<b>PAW-RE2D4-WH</b>	Display control for hotel rooms, white
<b>PAW-RE2D4-BK</b>	Display control for hotel rooms, black

**P2/R2 Technical focus**

- nanoe™ X (Generator Mark 3) built-in
- Maximum 65%\* improvement in cooling operation vs. conventional model with DC fan motor upgrade
- Pipes can be connected to either side of the unit from the bottom or rear
- Easy to install
- Removable air discharge grille gives flexible airflow (P2 only)
- Front panel opens fully for easy maintenance (P2 only)
- Room for condensate pump (P2 only)

\*MP2 type 4,5 kW model.

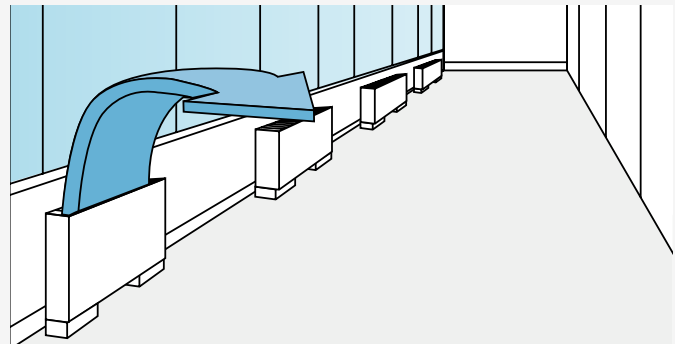
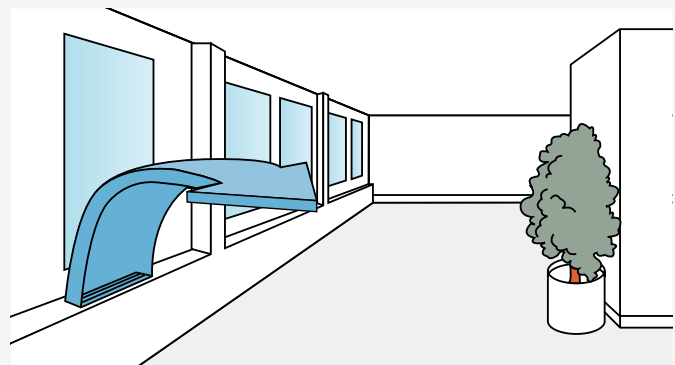
**Effective perimeter handling****Perimeter air conditioning with high interior quality**

INTERNET CONTROL: Optional.



## Hydrokit for ECOi, water at 45 °C - R410A

Connect the Hydrokit to your VRF system, together with other indoor units.

Total system performs high energy efficiency through heat recovering operation, and it gives an advantage for sustainability related assessment methods, such as BREEAM in UK.

COMPATIBLE WITH ALL PANASONIC CONNECTIVITY SOLUTIONS. FOR DETAILED INFORMATION GO TO THE CONTROL SYSTEMS SECTION



Indoor unit				S-80MW1E5	S-125MW1E5
Power supply	Voltage	V		230	230
	Phase			Single phase	Single phase
	Frequency	Hz		50	50
Cooling capacity			kW	8,0	12,5
Heating capacity			kW	9,0	14,0
Maximum temperature			°C	-45 / -65 <sup>1)</sup>	-45 / -65 <sup>1)</sup>
Dimension	H x W x D		mm	892 x 502 x 353	892 x 502 x 353
Water pipe connector			Inch	R 1 ¼	R 1 ¼
Water pump (built-in)				DC motor (A class)	DC motor (A class)
Water flow rate	Cool	L/min		22,90	35,80
	Heat	L/min		25,80	40,10
Piping diameter	Liquid	Inch (mm)		3/8 (9,52)	3/8 (9,52)
	Gas	Inch (mm)		5/8 (15,88)	5/8 (15,88)
	Drain	mm		15 ~ 17 (inner size)	15 ~ 17 (inner size)
Operation range	Cool	Ambient	°C	+10 ~ +43	+10 ~ +43
		Water	°C	+5 ~ +20	+5 ~ +20
	Heat	Ambient	°C	-20 ~ +43	-20 ~ +43
		Water	°C	+25 ~ +45	+25 ~ +45
Connectable system	3-Pipe ECOi EX MF3 Series (heat recovery type - system capable up to 48 HP)				
Maximum Indoor ratio (connectable hydrokit module capacity ratio)	Total indoor unit + Hydrokit capacity: up to 130% (**~ **% vs total outdoor unit capacity)				

1) Maximum 45 °C by refrigerant circuit (heat pump cycle), over 45 °C is provided by electric heater operation.

### Accessories

**CZ-RTC5B** Wired remote controller with Econavi function

## Basic principle and advantage.

Hydrokit module provides hot water by using waste heat that is recovered from standard air-conditioning indoor unit in cooling mode.

## Technical focus

- Only with 3-Pipe ECOi EX MF3 Series outdoor units
- Remote controller CZ-RTC5B common use with DX coil indoor units PACi and ECOi

## Hydrokit control function / CZ-RTC5B

- CZ-RTC5B can be used for hydrokit and also normal indoor unit. CZ-RTC5B checks the type of connected unit and switches between hydrokit and air conditioner display automatically

- Hydrokit mode (tank or air conditioning mode) is set during initial startup

## Overview: hydromodule in VRF system

- Multiple hydromodule connection in same circuit is available
- The mode of each module can be individually set from either hot water or space heating / cooling (once set the units cannot operate in another mode, resetting will be required)
- 3-Pipe control solenoid valve kit is necessary for each indoor unit and hydromodule

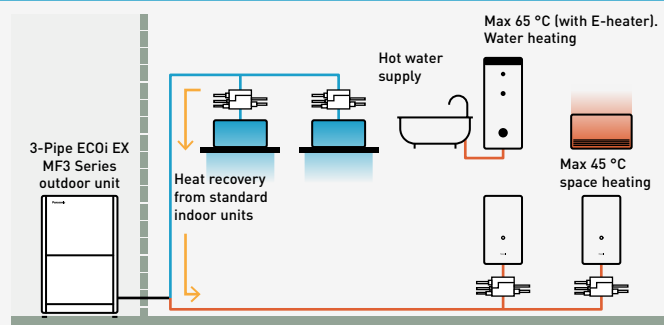

\*Cold water also available.

# Water heat exchanger for hydronic applications

Panasonic water heat exchanger available with ECOi systems. Those are suitable not only for new projects but also for the old chiller systems to be replaced.



## ECOi water heat exchanger

Electrical VRF with water heat exchanger

- With this easy to install water heat exchanger unit, you can now cover projects up to 51 kW hot water demand or 44 kW on chilled application in an efficient and cost effective way

### System example.

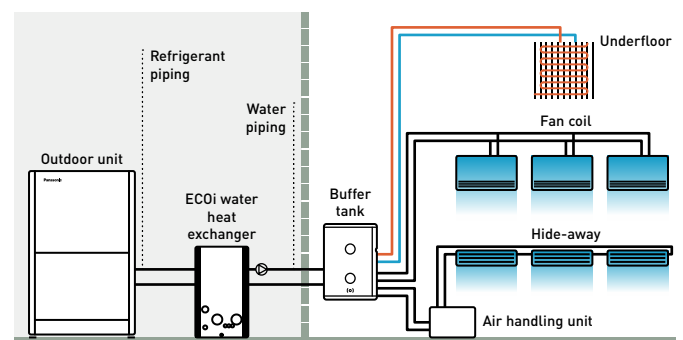

A buffer tank of minimum 280 l for 28 kW and 500 l for 50 kW is always needed.



## 2-Pipe ECOi EX ME2 Series with water heat exchanger for chilled and hot water production - R410A

### Water heat exchanger (WHE) for hydronic applications.

WHE for ECOi EX systems controlled by a CZ-RTC5B timer remote control.

Energy efficient capacity control with superior external static pressure is now ready.

Availability of easy vertical stacking allows installations in a limited space (up to 3 units)\*.

Stainless steel plate heat exchanger with anti-freeze protection control.

Change over between heating and cooling operation.

\*Stacking kit (PAW-3WSK) is necessary.

Hydrokit with A class water pump		PAW-250WP5G1	PAW-500WP5G1
Hydrokit without pump		PAW-250W5G1	PAW-500W5G1
Cooling capacity (A 35 °C, W 7 °C)	kW	25,0	50,0
Heating capacity	kW	28,0	56,0
Heating capacity (A +7 °C, W 45 °C)	kW	28,0	56,0
COP (A +7 °C, W 45 °C)	W/W	2,97	3,10
<b>Energy efficiency class at 35 °C <sup>1)</sup></b>		<b>A++</b>	<b>A++</b>
<b>η<sub>s,h</sub> (LOT1) <sup>2)</sup></b>		<b>152,0%</b>	<b>152,0%</b>
Dimension	H x W x D	mm	1000 x 575 x 1110
Net weight		kg	135 (140 with pump)
Water pipe connector			Rp2 Female thread (50A)
Heating water flow (ΔT=5 K, 35 °C)	m <sup>3</sup> /h		5,16
Electric backup heater	kW		Not equipped
Flow switch			Equipped
Water filter			Equipped
Input power with A class water pump / without pump	kW	0,329 / 0,024	0,574 / 0,024
Maximum current with A class water pump / without pump	A	1,43 / 0,10	2,50 / 0,10
<b>Outdoor unit</b>		<b>U-10ME2E8</b>	<b>U-20ME2E8</b>
Sound pressure	dB(A)		56
Dimension	H x W x D	mm	1842 x 770 x 1000
Net weight		kg	210
Piping diameter	Liquid	Inch (mm)	3/8 (9,52)
	Gas	Inch (mm)	7/8 (22,22)
Pipe length range / Pipe length for nominal capacity	m		170 / 7,5
Elevation difference (in / out)	m		50 (OU above) 35 (OU below)
Pre-charged pipe length / Additional gas amount (R410A)	m / g/m		0 < / Refer to manual
Refrigerant (R410A) / CO <sub>2</sub> Eq.	kg		5,6 (need additional gas amount at site)
Operating range	Heat Min ~ Max	°C	-11 ~ +15 <sup>3)</sup>
Water outlet temperature range	Cool Min ~ Max	°C	+5 ~ +15
	Heat Min ~ Max	°C	+35 ~ +45

1) Unit efficiency energy level: Scale from A+++ to D. 2) Seasonal space cooling / heating energy efficiency following COMMISSION REGULATION (EU) 813/2013. 3) With accessory low temperature kit -25 ~ +15 °C. Available only as a spare part.

Performance calculation in agreement with Eurovent. Sound pressure measured at 1 m from the outdoor unit and at 1,5 m height.

### Accessories

**PAW-3WSK** Stacking kit for vertically stacking up to 3 WHE (4 pieces per Kit)

### Stacking kit PAW-3WSK.

It is possible to stack up to 3 units. When stacking units, always anchor the bottom unit to the ground using the anchor holes.

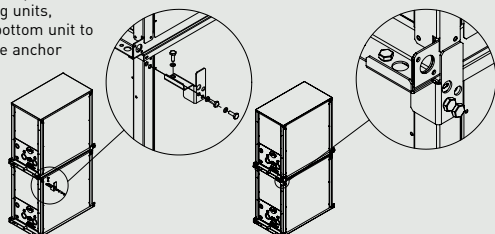

### Technical focus

- Heating, cooling and DHW
- A class water pump included (only in P model)
- Flexible modularity from 25 kW
- Better partial load vs standard chiller system
- Compatible with all centralized controllers
- Maximum distance between outdoor unit and WHE: 170 m
- Maximum hot water outlet temperature: 45 °C
- Minimum chilled water outlet temperature: 5 °C
- Outdoor temperature range in heating mode: -11 °C to +15 °C (with low temperature kit -25 °C\*)

\*Available as a spare part.



**AHU connection kit MAH4M for ECOi 2-Pipe - R32**

- Space-saving compact casing
- Direct Modbus communication without the need for an additional interface
- Accurate control with a pressure transducer
- PAW-P+100MAH4M (H x W x D): 300 x 400 x 150 mm, 11 kg

R32



Built-in controller.

ECO i EX ECO i

AHU kit PAW-P+100MAH4M			4 HP	5 HP	6 HP	8 HP LZ2	8 HP MZ1	10 HP LZ2	10 HP MZ1	12 HP
AHU connection kit			116EEVPACK	116EEVPACK	116EEVPACK	116EEVPACK	116EEVPACK	133EEVPACK	133EEVPACK	133EEVPACK
Outdoor unit			U-4LZ2E5(8)	U-5LZ2E5(8)	U-6LZ2E5(8)	U-8LZ2E8	U-8MZ1E8	U-10LZ2E8	U-8MZ1E8	U-10MZ1E8
Nominal cooling capacity	kW		12,0	14,0	16,0	22,4	22,4	28,0	28,0	33,5
Nominal heating capacity	kW		12,5	16,0	17,0	25,0	25,0	28,0	31,5	37,5
Minimum cooling continuous <sup>1)</sup>	kW		6,6	6,6	6,6	6,6	6,6	10,7	10,7	10,7
Minimum heating continuous <sup>2)</sup>	kW		7,4	7,4	7,4	7,4	7,4	12,1	12,1	12,1
Air flow volume	Min	m <sup>3</sup> /h	1100	1100	1100	1700	1700	2000	2000	2000
	Max	m <sup>3</sup> /h	4000	5000	5000	8000	10000	8600	10000	10000
AHU DX coil heat exchanger volume	Min	dm <sup>3</sup>	1,5	1,5	1,5	2,0	2,0	2,0	2,0	2,0
	Max	dm <sup>3</sup>	5,5	6,3	7,0	7,0	8,5	7,0	10,0	12,0
Piping length	Min / Max	m	10/60	10/60	10/60	10/70	10/100	10/70	10/100	10/100
Maximum branch pipe length	m		12	12	12	12	12	12	12	12
Maximum pipe length difference after 1st joint	m		10	10	10	10	10	10	10	10
Maximum elevation difference (in / out)	m		10	10	10	10	10	10	10	10
Piping connections EEV	mm		8	8	8	10	10	10	10	10
Piping diameter branch pipe	Liquid	Inch (mm)	3/8(9,52)	3/8(9,52)	3/8(9,52)	3/8(9,52)	3/8(9,52)	3/8(9,52)	3/8(9,52)	3/8(9,52)
	Gas	Inch (mm)	5/8(15,88)	5/8(15,88)	5/8(15,88)	3/4(19,05)	3/4(19,05)	7/8(22,22)	3/4(19,05)	7/8(22,22)
On coil temperature	Cool Min ~ Max	°C DB	12/32	12/32	12/32	12/32	12/32	12/32	12/32	12/32
		°C WB	8~25	8~25	8~25	8~25	8~25	8~25	8~25	8~25
	Heat Min ~ Max	°C DB	0~32 <sup>3)</sup>	0~32 <sup>3)</sup>	0~32 <sup>3)</sup>	0~32 <sup>3)</sup>	0~32 <sup>3)</sup>	0~32 <sup>3)</sup>	0~32 <sup>3)</sup>	0~32 <sup>3)</sup>
Outdoor temperature	Cool Min ~ Max	°C DB	-10~52	-10~52	-10~52	-10~52	-10~50	-10~52	-10~50	-10~50
	Heat Min ~ Max	°C WB	-20~18	-20~18	-20~18	-20~18	-25~24 <sup>4)</sup>	-20~18	-25~24 <sup>4)</sup>	-25~24 <sup>4)</sup>

1) At rated condition with 35 °C DB outdoor and 27 °C DB / 19 °C WB on coil. 2) At rated condition with 7 °C DB / 6 °C WB outdoor and 20 °C DB on coil. 3) In case of on coil temperature of 5 °C or below and of 31 °C and above air flow would be restricted. 4) In case of on coil temperature > +18 °C WB in heating mode, intermittent operation could happen.

**Technical focus**

- Maximum capacity / system: 48 HP (134 kW\*)
- Selectable expansion valve packs depending on the capacity
- DC 12 V outlet available without optional interface
- Maximum elevation difference indoor/outdoor unit: 10 m
- Elevation difference (indoor unit / indoor unit): 4 m
- In / out connection capacity ratio: 50~100%
- Maximum number of AHU connection kits: 1 unit
- Outdoor temperature range in heating: -20~+15 °C
- Available temperature range for the suction air at AHU connection kit: cool: +18~+32 °C / heat: +16~+30 °C
- The system's set temperature can be selected either as the default setting discharge air temperature (supply room temperature) or the suction air set temperature (or room return air temperature)
- Accurate control with a pressure transducer

- Direct Modbus communication with a built-in Modbus S-Link interface
- Various technical parameters available with Modbus
- SG Ready fulfilled. Demand input can be set Thermostat OFF or 40~200% by the user
- Defrost operation signal, compressor status ON / OFF output
- Display an error message concerning drain water overflow
- Connectable with S-Link system. Special care for electrical noise may be necessary depending on the on-site system
- Fan control signal output to manage the air flow [ON / OFF]
- Alarm status monitoring output

\*Nominal cooling capacity.

Accessories	
<b>PAW-P+102SENSPACK</b>	AHU connection kit sensor pack 1 (2 pcs of SENSOR PT1000 HT IP67 -50/250 CABLE 6 m PCK)
<b>PAW-P+116EEVPACK</b>	EEV pack 1 (1 pc of expansion valve ≤ 16,0 kW (R32 / R410A) and 1 pc of UNIPOLAR stator and filter strainers)
<b>PAW-P+133EEVPACK</b>	EEV pack 2 (1 pc of expansion valve ≤ 33,0 kW (R32 / R410A) and 1 pc of UNIPOLAR stator and filter strainers)
<b>PAW-P+145EEVPACK</b>	EEV pack 3 (1 pc of expansion valve ≤ 45,0 kW (R32 / R410A) and 1 pc of UNIPOLAR stator and filter strainers)

Accessories	
<b>PAW-P+156EEVPACK</b>	EEV pack 4 (1 pc of expansion valve ≤ 61,5 kW (R32 / R410A) and 1 pc of UNIPOLAR stator and filter strainers)
<b>PAW-P+174EEVPACK</b>	EEV pack 5 (1 pc of expansion valve ≤ 96,0 kW (R32 / R410A) and 1 pc of UNIPOLAR stator and filter strainers)
<b>PAW-P+100PGNEPACK</b>	Remote control pack (1 pc of PGNE 132 x 64 mm, mounting panel and 1 pc of cable L= 1,5 m, telephone connectors)



R32

### AHU connection kit MAH4M for ECOi 2-Pipe combination from 16 to 48 HP - R32

ECO i EX ECO i



Built-in controller.

AHU kit PAW-P+100MAH4M		16 HP	18 HP	20 HP	22 HP	24 HP	26 HP	28 HP	30 HP	
AHU connection kit		145EEVPACK	145EEVPACK	145EEVPACK	145EEVPACK	156EEVPACK	156EEVPACK	156EEVPACK	174EEVPACK	
Outdoor unit		2×U-8MZ1E8	U-8MZ1E8 + U-10MZ1E8	2×U-10MZ1E8	U-10MZ1E8 + U-12MZ1E8	2×U-12MZ1E8	2×U-8MZ1E8 + U-10MZ1E8	U-8MZ1E8 + 2×U-10MZ1E8	3×U-10MZ1E8	
Multi combination		8+8	8+10	10+10	10+12	12+12	8+8+10	8+10+10	10+10+10	
Nominal cooling capacity	kW	44,8	50,4	56,0	61,5	67,0	72,8	78,4	84,0	
Nominal heating capacity	kW	50,0	56,5	63,0	69,0	75,0	81,5	88,0	94,5	
Minimum cooling continuous <sup>1)</sup>	kW	15,9	15,9	15,9	15,9	23,3	23,3	23,3	32,8	
Minimum heating continuous <sup>2)</sup>	kW	18,0	18,0	18,0	18,0	26,3	26,3	26,3	37,1	
Air flow volume	Min	m <sup>3</sup> /h	3400	3700	4000	4000	4000	5400	6000	
	Max	m <sup>3</sup> /h	16000	20000	20000	20000	20000	24000	30000	
AHU DX coil heat exchanger volume	Min	dm <sup>3</sup>	4,0	4,0	4,0	4,0	4,0	6,0	6,0	
	Max	dm <sup>3</sup>	15,0	18,0	20,0	22,0	24,0	27,0	30,0	
Piping length	Min / Max	m	10/100	10/100	10/100	10/100	10/100	10/100	10/100	
Maximum branch pipe length	m	12	12	12	12	12	12	12	12	
Maximum pipe length difference after 1st joint	m	10	10	10	10	10	10	10	10	
Maximum elevation difference (in / out)	m	10	10	10	10	10	10	10	10	
Piping connections EEV	mm	10	10	10	10	16	16	16	7/8"	
Piping diameter branch pipe	Liquid	Inch (mm)	1/2(12,70)	1/2(12,70)	1/2(12,70)	1/2(12,70)	1/2(12,70)	1/2(12,70)	1/2(12,70)	5/8(15,88)
	Gas	Inch (mm)	1 1/8(28,58)	1 1/8(28,58)	1 1/8(28,58)	1 1/8(28,58)	1 1/8(28,58)	1 1/8(28,58)	1 1/8(28,58)	1 3/8(34,98)
On coil temperature	Cool Min ~ Max	°C DB	12~32	12~32	12~32	12~32	12~32	12~32	12~32	12~32
		°C WB	8~25	8~25	8~25	8~25	8~25	8~25	8~25	8~25
Outdoor temperature	Heat Min ~ Max	°C DB	0~32 <sup>3)</sup>	0~32 <sup>3)</sup>	0~32 <sup>3)</sup>	0~32 <sup>3)</sup>	0~32 <sup>3)</sup>	0~32 <sup>3)</sup>	0~32 <sup>3)</sup>	0~32 <sup>3)</sup>
		°C WB	-25~50	-10~50	-10~50	-10~50	-10~50	-10~50	-10~50	-10~50
Outdoor temperature	Heat Min ~ Max	°C DB	-10~50	-10~50	-10~50	-10~50	-10~50	-10~50	-10~50	-10~50
		°C WB	-25~24 <sup>4)</sup>	-25~24 <sup>4)</sup>	-25~24 <sup>4)</sup>	-25~24 <sup>4)</sup>	-25~24 <sup>4)</sup>	-25~24 <sup>4)</sup>	-25~24 <sup>4)</sup>	-25~24 <sup>4)</sup>

AHU kit PAW-P+100MAH4M		32 HP	34 HP	36 HP	38 HP	40 HP	42 HP	44 HP	46 HP	48 HP
AHU connection kit		174EEVPACK	174EEVPACK	174EEVPACK	174EEVPACK	174EEVPACK	174EEVPACK	174EEVPACK	174EEVPACK	174EEVPACK
Outdoor unit		2×U-10MZ1E8 + U-12MZ1E8	U-10MZ1E8 + 2×U-12MZ1E8	3×U-12MZ1E8	U-8MZ1E8 + 3×U-10MZ1E8	4×U-10MZ1E8	3×U-10MZ1E8 + U-12MZ1E8	2×U-10MZ1E8 + 2×U-12MZ1E8	U-10MZ1E8 + 3×U-12MZ1E8	4×U-12MZ1E8
Multi combination		10+10+12	10+12+12	12+12+12	8+10+10+10	10+10+10+10	10+10+10+12	10+10+12+12	10+12+12+12	12+12+12+12
Nominal cooling capacity	kW	89,5	95,0	100,0	106,0	112,0	117,0	123,0	128,0	134,0
Nominal heating capacity	kW	100,0	106,0	112,0	119,0	126,0	132,0	138,0	144,0	150,0
Minimum cooling continuous <sup>1)</sup>	kW	32,8	32,8	32,8	32,8	32,8	32,8	32,8	32,8	32,8
Minimum heating continuous <sup>2)</sup>	kW	37,1	37,1	37,1	37,1	37,1	37,1	37,1	37,1	37,1
Air flow volume	Min	m <sup>3</sup> /h	6000	6000	6000	7700	8000	8000	8000	8000
	Max	m <sup>3</sup> /h	30000	30000	30000	34000	36000	38000	40000	40000
AHU DX coil heat exchanger volume	Min	dm <sup>3</sup>	6,0	6,0	6,0	8,0	8,0	8,0	8,0	8,0
	Max	dm <sup>3</sup>	32,0	34,0	36,0	38,0	40,0	42,0	44,0	46,0
Piping length	Min / Max	m	10/100	10/100	10/100	10/100	10/100	10/100	10/100	10/100
Maximum branch pipe length	m	12	12	12	12	12	12	12	12	12
Maximum pipe length difference after 1st joint	m	10	10	10	10	10	10	10	10	10
Maximum elevation difference (in / out)	m	10	10	10	10	10	10	10	10	10
Piping connections EEV	mm	7/8"	7/8"	7/8"	7/8"	7/8"	7/8"	7/8"	7/8"	7/8"
Piping diameter branch pipe	Liquid	Inch (mm)	5/8(15,88)	5/8(15,88)	5/8(15,88)	5/8(15,88)	5/8(15,88)	5/8(15,88)	5/8(15,88)	5/8(15,88)
	Gas	Inch (mm)	1 3/8(34,98)	1 3/8(34,98)	1 3/8(34,98)	1 3/8(34,98)	1 3/8(34,98)	1 3/8(34,98)	1 3/8(34,98)	1 3/8(34,98)
On coil temperature	Cool Min ~ Max	°C DB	12~32	12~32	12~32	12~32	12~32	12~32	12~32	12~32
		°C WB	8~25	8~25	8~25	8~25	8~25	8~25	8~25	8~25
Outdoor temperature	Heat Min ~ Max	°C DB	0~32 <sup>3)</sup>	0~32 <sup>3)</sup>	0~32 <sup>3)</sup>	0~32 <sup>3)</sup>	0~32 <sup>3)</sup>	0~32 <sup>3)</sup>	0~32 <sup>3)</sup>	0~32 <sup>3)</sup>
		°C WB	-10~50	-10~50	-10~50	-10~50	-10~50	-10~50	-10~50	-10~50
Outdoor temperature	Heat Min ~ Max	°C DB	-10~50	-10~50	-10~50	-10~50	-10~50	-10~50	-10~50	-10~50
		°C WB	-25~24 <sup>4)</sup>	-25~24 <sup>4)</sup>	-25~24 <sup>4)</sup>	-25~24 <sup>4)</sup>	-25~24 <sup>4)</sup>	-25~24 <sup>4)</sup>	-25~24 <sup>4)</sup>	-25~24 <sup>4)</sup>

1) At rated condition with 35 °C DB outdoor and 27 °C DB / 19 °C WB on coil. 2) At rated condition with 7 °C DB / 6 °C WB outdoor and 20 °C DB on coil. 3) In case of on coil temperature of 5 °C or below and of 31 °C and above air flow would be restricted. 4) In case of on coil temperature > +18 °C WB in heating mode, intermittent operation could happen.

**AHU connection kit MAH4M for ECOi 2-Pipe - R410A**

- Space-saving compact casing
- Direct Modbus communication without the need for an additional interface
- Accurate control with a pressure transducer
- PAW-P+100MAH4M (H x W x D): 300 x 400 x 150 mm, 11 kg



Built-in controller.

ECO *i* EX ECO *i*

AHU kit PAW-P+100MAH4M			4 HP	5 HP	6 HP	8 HP LE1	8 HP ME2	10 HP LE1
AHU connection kit			116EEVPACK	116EEVPACK	116EEVPACK	133EEVPACK	133EEVPACK	133EEVPACK
Outdoor unit			U-4LE2E5(8)	U-5LE2E5(8)	U-6LE2E5(8)	U-8LE1E8	U-8ME2E8	U-10LE1E8
Nominal cooling capacity	kW		12,0	14,0	16,0	22,4	22,4	28,0
Nominal heating capacity	kW		12,5	16,0	17,0	25,0	25,0	31,5
Minimum cooling continuous <sup>1)</sup>	kW		4,3	4,3	4,3	7,0	7,0	7,0
Minimum heating continuous <sup>2)</sup>	kW		5,0	5,0	5,0	8,1	8,1	8,1
Air flow volume	Min	m <sup>3</sup> /h	1100	1100	1100	1700	1700	2000
	Max	m <sup>3</sup> /h	4000	5000	5000	8000	10000	8600
AHU DX coil heat exchanger volume	Min	dm <sup>3</sup>	1,5	1,5	1,5	2,0	2,0	2,0
	Max	dm <sup>3</sup>	5,5	6,3	7,0	7,0	10,0	7,0
Piping length	Min / Max	m	10/100	10/100	10/100	10/100	10/100	10/100
Maximum branch pipe length		m	12	12	12	12	12	12
Maximum pipe length difference after 1st joint		m	10	10	10	10	10	10
Maximum elevation difference (in / out)		m	10	10	10	10	10	10
Piping connections EEV		mm	8	8	8	10	10	10
Piping diameter branch pipe	Liquid	Inch (mm)	3/8(9,52)	3/8(9,52)	3/8(9,52)	3/8(9,52)	3/8(9,52)	3/8(9,52)
	Gas	Inch (mm)	5/8(15,88)	5/8(15,88)	5/8(15,88)	3/4(19,05)	3/4(19,05)	7/8(22,22)
On coil temperature	Cool Min ~ Max	°C DB	12/32	12/32	12/32	12/32	12/32	12/32
		°C WB	8/25	8/25	8/25	8/25	8/25	8/25
	Heat Min ~ Max	°C DB	0/32 <sup>3)</sup>	0/32 <sup>3)</sup>	0/32 <sup>3)</sup>	0/32 <sup>3)</sup>	0/32 <sup>3)</sup>	0/32 <sup>3)</sup>
Outdoor temperature	Cool Min ~ Max	°C DB	-10/46	-10/46	-10/46	-10/46	-10/46	-10/46
	Heat Min ~ Max	°C WB	-20/18	-20/18	-20/18	-20/18	-25/18	-20/18

AHU kit PAW-P+100MAH4M			10 HP ME2	12 HP	14 HP	16 HP	18 HP	20 HP
AHU connection kit			133EEVPACK	133EEVPACK	145EEVPACK	145EEVPACK	145EEVPACK	156EEVPACK
Outdoor unit			U-10ME2E8	U-12ME2E8	U-14ME2E8	U-16ME2E8	U-18ME2E8	2×U-10ME2E8
Nominal cooling capacity	kW		28,0	33,5	40,0	45,0	50,0	56,0
Nominal heating capacity	kW		31,5	37,5	45,0	50,0	56,0	63,0
Minimum cooling continuous <sup>1)</sup>	kW		7,0	7,0	10,4	10,4	10,4	15,3
Minimum heating continuous <sup>2)</sup>	kW		8,1	8,1	12,0	12,0	12,0	17,5
Air flow volume	Min	m <sup>3</sup> /h	2000	2000	3500	3500	5000	5000
	Max	m <sup>3</sup> /h	10000	10000	12000	12000	20000	20000
AHU DX coil heat exchanger volume	Min	dm <sup>3</sup>	2,0	3,0	3,0	4,0	4,0	4,0
	Max	dm <sup>3</sup>	10,0	17,0	17,0	17,0	19,0	19,0
Piping length	Min / Max	m	10/100	10/100	10/100	10/100	10/100	10/100
Maximum branch pipe length		m	12	12	12	12	12	12
Maximum pipe length difference after 1st joint		m	10	10	10	10	10	10
Maximum elevation difference (in / out)		m	10	10	10	10	10	10
Piping connections EEV		mm	10	10	10	10	10	16
Piping diameter branch pipe	Liquid	Inch (mm)	3/8(9,52)	1/2(12,70)	1/2(12,70)	1/2(12,70)	5/8(15,88)	5/8(15,88)
	Gas	Inch (mm)	7/8(22,22)	1 1/8(28,58)	1 1/8(28,58)	1 1/8(28,58)	1 1/8(28,58)	1 1/8(28,58)
On coil temperature	Cool Min ~ Max	°C DB	12/32	12/32	12/32	12/32	12/32	12/32
		°C WB	8/25	8/25	8/25	8/25	8/25	8/25
	Heat Min ~ Max	°C DB	0/32 <sup>3)</sup>	0/32 <sup>3)</sup>	0/32 <sup>3)</sup>	0/32 <sup>3)</sup>	0/32 <sup>3)</sup>	0/32 <sup>3)</sup>
Outdoor temperature	Cool Min ~ Max	°C DB	-10/46	-10/46	-10/46	-10/46	-10/46	-10/46
	Heat Min ~ Max	°C WB	-25/18	-25/18	-25/18	-25/18	-25/18	-25/18

1) At rated condition with 35 °C DB outdoor and 27 °C DB / 19 °C WB on coil. 2) At rated condition with 7 °C DB / 6 °C WB outdoor and 20 °C DB on coil. 3) In case of on coil temperature of 5 °C or below and of 31 °C and above air flow would be restricted.



## AHU connection kit MAH4M for ECOi 2-Pipe combination from 22 to 34 HP - R410A

ECO *i* EX ECO *i*



Built-in controller.

AHU kit PAW-P+100MAH4M			22 HP	24 HP	26 HP	28 HP	30 HP	32 HP	34 HP	
AHU connection kit			156EEVPACK	174EEVPACK	174EEVPACK	174EEVPACK	174EEVPACK	174EEVPACK	174EEVPACK	
Outdoor unit			U-10ME2E8 + U-12ME2E8	2×U-12ME2E8	U-10ME2E8 + U-16ME2E8	U-12ME2E8 + U-16ME2E8	U-14ME2E8 + U-16ME2E8	2×U-16ME2E8	U-14ME2E8 + U-20ME2E8	
Multi combination			10+12	12+12	10+16	12+16	14+16	16+16	14+20	
Nominal cooling capacity			kW	61,5	68,0	73,0	78,5	85,0	90,0	96,0
Nominal heating capacity			kW	69,0	76,5	81,5	87,5	95,0	100,0	108,0
Minimum cooling continuous <sup>1)</sup>			kW	15,3	21,5	21,5	21,5	21,5	21,5	21,5
Minimum heating continuous <sup>2)</sup>			kW	17,5	24,7	24,7	24,7	24,7	24,7	24,7
Air flow volume	Min	m <sup>3</sup> /h	6000	6000	6000	6000	7000	7000	8500	
	Max	m <sup>3</sup> /h	24000	24000	24000	25000	25000	25000	30000	
AHU DX coil heat exchanger volume	Min	dm <sup>3</sup>	5,0	6,0	6,0	6,0	6,0	6,0	7,0	
	Max	dm <sup>3</sup>	27,0	34,0	27,0	34,0	34,0	34,0	36,0	
Piping length	Min / Max	m	10/100	10/100	10/100	10/100	10/100	10/100	10/100	
Maximum branch pipe length			m	12	12	12	12	12	12	12
Maximum pipe length difference after 1st joint			m	10	10	10	10	10	10	10
Maximum elevation difference (in / out)			m	10	10	10	10	10	10	10
Piping connections EEV			mm	16	7/8"	7/8"	7/8"	7/8"	7/8"	7/8"
Piping diameter branch pipe	Liquid	Inch (mm)	5/8(15,88)	5/8(15,88)	3/4(19,05)	3/4(19,05)	3/4(19,05)	3/4(19,05)	3/4(19,05)	
	Gas	Inch (mm)	1 1/8(28,58)	1 1/8(28,58)	1 1/4(31,75)	1 1/4(31,75)	1 1/4(31,75)	1 1/4(31,75)	1 1/4(31,75)	
On coil temperature	Cool Min ~ Max	°C DB	12/32	12/32	12/32	12/32	12/32	12/32	12/32	
		°C WB	8/25	8/25	8/25	8/25	8/25	8/25	8/25	
	Heat Min ~ Max	°C DB	0/32 <sup>3)</sup>	0/32 <sup>3)</sup>	0/32 <sup>3)</sup>	0/32 <sup>3)</sup>	0/32 <sup>3)</sup>	0/32 <sup>3)</sup>	0/32 <sup>3)</sup>	
Outdoor temperature	Cool Min ~ Max	°C DB	-10/46	-10/46	-10/46	-10/46	-10/46	-10/46	-10/46	
	Heat Min ~ Max	°C WB	-25/18	-25/18	-25/18	-25/18	-25/18	-25/18	-25/18	

1) At rated condition with 35 °C DB outdoor and 27 °C DB / 19 °C WB on coil. 2) At rated condition with 7 °C DB / 6 °C WB outdoor and 20°C DB on coil. 3) In case of on coil temperature of 5 °C or below and of 31 °C and above air flow would be restricted.

### Accessories

<b>PAW-P+102SENSPACK</b>	AHU connection kit sensor pack 1 (2 pcs of SENSOR PT1000 HT IP67 -50/250 CABLE 6 m PCK)
<b>PAW-P+116EEVPACK</b>	EEV pack 1 (1 pc of expansion valve ≤ 16,0 kW (R32 / R410A) and 1 pc of UNIPOLAR stator and filter strainers)
<b>PAW-P+133EEVPACK</b>	EEV pack 2 (1 pc of expansion valve ≤ 33,0 kW (R32 / R410A) and 1 pc of UNIPOLAR stator and filter strainers)
<b>PAW-P+145EEVPACK</b>	EEV pack 3 (1 pc of expansion valve ≤ 45,0 kW (R32 / R410A) and 1 pc of UNIPOLAR stator and filter strainers)

### Accessories

<b>PAW-P+156EEVPACK</b>	EEV pack 4 (1 pc of expansion valve ≤ 61,5 kW (R32 / R410A) and 1 pc of UNIPOLAR stator and filter strainers)
<b>PAW-P+174EEVPACK</b>	EEV pack 5 (1 pc of expansion valve ≤ 96,0 kW (R32 / R410A) and 1 pc of UNIPOLAR stator and filter strainers)
<b>PAW-P+100PGNEPACK</b>	Remote control pack (1 pc of PGNE 132 x 64 mm, mounting panel and 1 pc of cable L= 1,5 m, telephone connectors)

### Advanced energy recovery ventilation - ZY Series

- Extended 9 model line-up including 2000 m<sup>3</sup>/h model
- DC motors
- ESP up to 150 Pa
- F7 grade filter built-in as a standard
- Intuitive remote controller
- BMS integration with RS485



Rated flow rate			150 m <sup>3</sup> /h	250 m <sup>3</sup> /h	350 m <sup>3</sup> /h	500 m <sup>3</sup> /h	650 m <sup>3</sup> /h	800 m <sup>3</sup> /h	1000 m <sup>3</sup> /h	1500 m <sup>3</sup> /h	2000 m <sup>3</sup> /h		
<b>Indoor unit</b>			FV-15ZY1G	FV-25ZY1G	FV-35ZY1G	FV-50ZY1G	FV-65ZY1G	FV-80ZY1G	FV-1KZY1G	FV-1HZY1G	FV-2KZY1G		
Power supply	Voltage	V	220 - 240	220 - 240	220 - 240	220 - 240	220 - 240	220 - 240	220 - 240	220 - 240	220 - 240		
	Phase		Single phase	Single phase	Single phase	Single phase	Single phase	Single phase	Single phase	Single phase	Single phase		
	Frequency	Hz	50	50	50	50	50	50	50	50	50		
Motor type			DC	DC	DC	DC	DC	DC	DC	DC	DC		
<b>ERV</b>													
Air flow	Max	m <sup>3</sup> /h	150	250	350	500	650	800	1000	1500	2000		
External static pressure	Max	Pa	100	120	140	130	150	150	150	130	130		
Sound pressure <sup>2)</sup>	Max	dB(A)	37	38	39	43	45	45	46	49	51		
Input power	Max	W	76~84	106~117	141~155,5	180~198	420~462	470~517	550~605	940~1034	1100~1210		
<b>Heat exchange efficiency <sup>3)</sup></b>													
Cooling	Max	%	68,0	69,0	71,0	65,0	64,0	63,0	65,0	63,0	65,0		
Heating	Max	%	83,0	82,0	83,0	81,0	82,0	83,0	82,0	83,0	82,0		
<b>Enthalpy exchange efficiency</b>													
Cooling	Max	%	66,0	66,0	67,0	62,5	62,5	63,5	63,0	63,5	63,0		
Heating	Max	%	76,0	74,0	75,0	73,0	72,0	73,0	74,0	73,0	74,0		
Adapter diameter			mm	100	150	150	200	200	250	250	250		
Dimension			HxWxD	mm	289x610 x860	289x735 x860	331x874 x968	331x1016 x968	404x954 x1008	404x1004 x1224	404x1231 x1224	808x1004 x1224	808x1231 x1224
Net weight			kg	23	27	37	40	48	60	64	119	142	

1) Different dimensions depending on models. 2) Measurement of noise 1,5 m below the center of the main unit (anechoic chamber). 3) Heat exchange efficiency measurement standard JIS B 8628 (2003). \*JIS B 8628 (2017) is used in the measurement environment. \*A remote controller is included.

Accessories	
<b>FV-FP15ZY1G</b>	Replacement high-efficiency filter for FV-15ZY1G
<b>FV-FP25ZY1G</b>	Replacement high-efficiency filter for FV-25ZY1G
<b>FV-FP35ZY1G</b>	Replacement high-efficiency filter for FV-35ZY1G
<b>FV-FP50ZY1G</b>	Replacement high-efficiency filter for FV-50ZY1G

Accessories	
<b>FV-FP65ZY1G</b>	Replacement high-efficiency filter for FV-65ZY1G
<b>FV-FP80ZY1G</b>	Replacement high-efficiency filter for FV-80ZY1G and FV-1HZY1G <sup>1)</sup>
<b>FV-FP1KZY1G</b>	Replacement high-efficiency filter for FV-1KZY1G and FV-2KZY1G <sup>1)</sup>
<b>PAW-ERV-IAQCT</b>	IAQ Controller

1) 2 sets of filters required for those models.

### Recovers up to 83% of the heat in the outgoing air

ZY Series achieves more than 80% of heat exchange efficiency in all the line-up <sup>1)</sup>. The high recovery rate optimizes operation cost and can be considered as a sustainable solution.

1) Heating operation, H1 speed setting.

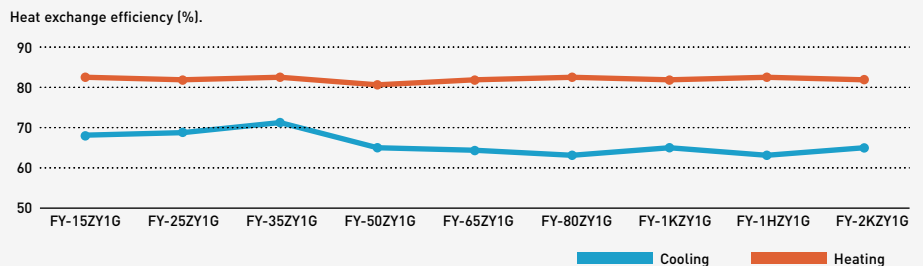

Ventilation volume setting PQ curve example.

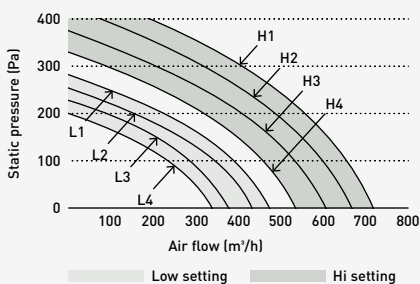

### Easy adjust for air volume balance

DC motors are equipped with independent control settings for air supply and exhaust. Air volume balance can be easily adjusted with 4 speeds settings for each Hi / Low operation.

### Intuitive remote controller with RS485 connection.

- Simple and clean screen with white back light panel
- RS485 terminal equipped to integrate with Building Management Systems
- Metal switch box is included in the package





## Energy recovery ventilation with DX coil - HRPT Series - R32 / R410A

COMPATIBLE WITH ALL PANASONIC CONNECTIVITY SOLUTIONS. FOR DETAILED INFORMATION GO TO THE CONTROL SYSTEMS SECTION



Indoor unit with high-efficiency heat exchanger			PAW-HRPT40HX	PAW-HRPT80HX	PAW-HRPT120HX	PAW-HRPT160HX	PAW-HRPT200HX				
Power supply	Voltage	V	230	230	230	230	380				
	Phase		Single phase	Single phase	Single phase	Single phase	Three phase				
	Frequency	Hz	50	50	50	50	50				
<b>Heat recovery ventilation <sup>1)</sup></b>			<b>Cooling</b>	<b>Heating</b>	<b>Cooling</b>	<b>Heating</b>	<b>Cooling</b>	<b>Heating</b>	<b>Cooling</b>	<b>Heating</b>	
Temperature efficiency	%	63,4	76,7	60,0	73,5	61,4	75,0	62,2	76,0	59,4	73,2
Enthalpy efficiency	%	52,3	53,2	47,8	49,2	49,5	50,7	50,0	51,2	46,8	48,3
Weight	kg	70		114		150		184		194	

Indoor unit with sensible heat exchanger			PAW-HRPT40	PAW-HRPT80	PAW-HRPT120	PAW-HRPT160	PAW-HRPT200				
Power supply	Voltage	V	230	230	230	230	380				
	Phase		Single phase	Single phase	Single phase	Single phase	Three phase				
	Frequency	Hz	50	50	50	50	50				
<b>Heat recovery ventilation <sup>1)</sup></b>			<b>Cooling</b>	<b>Heating</b>	<b>Cooling</b>	<b>Heating</b>	<b>Cooling</b>	<b>Heating</b>	<b>Cooling</b>	<b>Heating</b>	
Temperature efficiency	%	84,6	84,9	84,3	84,7	84,8	85,2	84,7	85,1	83,8	84,2
Weight	kg	66		110		145		180		190	

Common data		DX coil <sup>2)</sup>		Cooling	Heating	Cooling	Heating	Cooling	Heating	Cooling	Heating	Cooling	Heating
Total / Sensible capacity	kW	3,0 / 2,4	3,2	6,0 / 4,1	6,2	8,0 / 5,5	8,3	10,0 / 7,1	11,0	12,5 / 8,6	12,8		
Maximum input current	A	1,5		2,2		4,1		4,4		3,3			
Sound pressure @1 m / @3 m	dB(A)	41 / 35		51 / 43		42 / 36		49 / 41		57 / 49			
Air flow	Nominal m <sup>3</sup> /h	400		800		1200		1600		2000			
External static pressure	High Pa	150		150		150		150		150			
Dimension	HxWxD mm	286 x 1003 x 1475		425 x 1226 x 1878		425 x 1628 x 1878		425 x 2030 x 1720		425 x 2030 x 1878			
Piping diameter	Liquid Inch (mm)	1/4 (6,35)		1/4 (6,35)		3/8 (9,52)		3/8 (9,52)		3/8 (9,52)			
	Gas Inch (mm)	1/2 (12,70)		1/2 (12,70)		5/8 (15,88)		5/8 (15,88)		5/8 (15,88)			

1) Data refers to the following conditions (UNI EN 13141-7): nominal air flow, heating external air 5 °C with 72% r. / expelled air 25 °C with 28% r. - cooling 35 °C with 40% / expelled air 27 °C with 48%. 2) Data refers to the following conditions: nominal air flow, cooling inlet coil summer 27 °C with 48% / heating inlet coil winter 20 °C with 50% r. \*Image is for PAW-HRPT40.

### Accessories

<b>CZ-RTC6W</b>	CONEX wired remote controller (non-wireless), white
<b>CZ-RTC6WBL</b>	CONEX wired remote controller with Bluetooth®, white
<b>CZ-RTC6</b>	CONEX wired remote controller (non-wireless), black
<b>CZ-RTC6BL</b>	CONEX wired remote controller with Bluetooth®, black
<b>CZ-RTC5B</b>	Wired remote controller with Econavi function

### Accessories

<b>CZ-RWS3 + CZ-RWRC3</b>	Infrared remote controller and receiver
<b>PAW-RE2C4-MOD-WH</b>	Room controller for hotel rooms, white
<b>PAW-RE2C4-MOD-BK</b>	Room controller for hotel rooms, black
<b>PAW-RE2D4-WH</b>	Display control for hotel rooms, white
<b>PAW-RE2D4-BK</b>	Display control for hotel rooms, black

### Technical focus

- Dual flow ventilation with EC fan, featuring high-efficiency heat recovery (>85% η)
- 5 model line-up is available with air flow rates of 400, 800, 1200, 1600 and 2000 m<sup>3</sup>/h
- 2 types of polystyrene heat exchanger (high-efficiency and sensible) with counter-current flows and integrated bypass as standard
- Automatic defrosting of the exchanger
- Low consumption and EC motors with electronic speed control ensure high useful static pressure for circular inlet connection to air ducts
- Wide ambient temperature range up to +50 °C and down to -15 °C
- Modbus connection available

### Interconnection to outdoor / indoor units

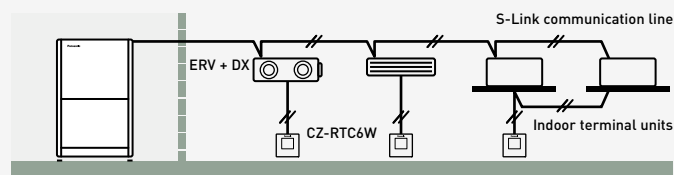

### Aeraulic performance

EC motors with electronic speed control ensure high values of effective static pressure for ducting.

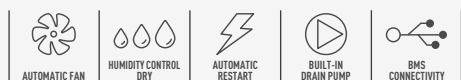
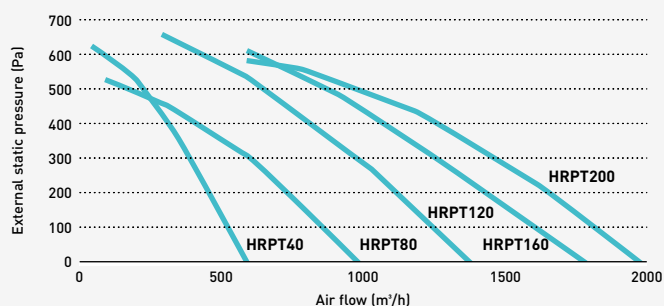

**NEW! Air curtain with DX coil, connected to ECOi 2-Pipe**

- Advanced defrost control without disrupting the air curtain effect or causing cold drafts
- Three installation options: suspended, cassette, or built-in
- Quiet operation

\*Includes two remote controllers: a touch screen remote controller and an intelligent built-in controller for setup.



Touch screen remote controller\*.

Air outlet height 2,8 m			PAW-M2-100R	PAW-M2-150R	PAW-M2-200R	PAW-M2-250R
<b>Outdoor unit minimum size</b>			<b>4 HP</b>	<b>5 HP</b>	<b>8 HP</b>	<b>10 HP</b>
Cooling capacity <sup>1)</sup>	Max	kW	7,6	12,0	16,3	20,5
Heating capacity <sup>2)</sup>	Max	kW	9,4	15,0	20,7	25,6
Air flow	High	m <sup>3</sup> /h	1800	2700	3600	4500
Heat Exchanger	Volume	L	1,60	2,80	3,90	5,10
Electric consumption fan	230 V / 50 Hz	kW	0,33	0,50	0,66	0,83
Current	230 V / 50 Hz	A	2,40	3,60	4,80	6,00
Sound pressure <sup>3)</sup>	Max	dB(A)	56	57	58	59
Dimension	H x W x D (x D <sup>4)</sup> )	mm	300 x 1000 x 750 (x 890)	300 x 1500 x 750 (x 890)	300 x 2000 x 750 (x 890)	300 x 2500 x 750 (x 890)
Net weight		kg	61	74	96	138
Fan type			EC	EC	EC	EC
Piping diameter <sup>5)</sup>	Liquid / Gas	Inch (mm)	1/4 (6,35) / 1/2 (12,70)	3/8 (9,52) / 5/8 (15,88)	3/8 (9,52) / 5/8 (15,88)	1/2 (12,70) / 7/8 (22,22)
Door width		m	1,0	1,5	2,0	2,5
Refrigerant			R32 / R410A	R32 / R410A	R32 / R410A	R32 / R410A

**Tentative data**

Air outlet height 3,2 m			PAW-M3-100R	PAW-M3-150R	PAW-M3-200R	PAW-M3-250R
<b>Outdoor unit minimum size</b>			<b>4 HP</b>	<b>6 HP</b>	<b>10 HP</b>	<b>10 HP</b>
Cooling capacity <sup>1)</sup>	Max	kW	10,0	13,8	21,7	25,2
Heating capacity <sup>2)</sup>	Max	kW	11,4	17,0	25,7	30,2
Air flow	High	m <sup>3</sup> /h	2400	3200	4900	5700
Heat Exchanger	Volume	L	1,60	2,80	3,90	5,10
Electric consumption fan	230 V / 50 Hz	kW	0,50	0,66	0,99	1,16
Current	230 V / 50 Hz	A	3,60	4,80	7,20	8,40
Sound pressure <sup>3)</sup>	Max	dB(A)	58	59	60	61
Dimension	H x W x D (x D <sup>4)</sup> )	mm	300 x 1000 x 750 (x 890)	300 x 1500 x 750 (x 890)	300 x 2000 x 750 (x 890)	300 x 2500 x 750 (x 890)
Net weight		kg	65	78	104	145
Fan type			EC	EC	EC	EC
Piping diameter <sup>5)</sup>	Liquid / Gas	Inch (mm)	3/8 (9,52) / 5/8 (15,88)	3/8 (9,52) / 5/8 (15,88)	1/2 (12,70) / 7/8 (22,22)	1/2 (12,70) / 7/8 (22,22)
Door width		m	1,0	1,5	2,0	2,5
Refrigerant			R32 / R410A	R32 / R410A	R32 / R410A	R32 / R410A

1) Minimum discharge temperature of 17 °C. With an air intake temperature of 27 °C RH 50%, evaporation temperature of 4,5 °C, SH 3 K, SC 20 K. 2) Air intake temperature of 20 °C, refrigerant R32, outside temperature -0 °C, condensation temperature 48 °C, SH 40 K and SC 3 K. 3) Measured in distance from 3,0 m. 4) Depth including brackets for cassette mounting and built-in models. For built-in model height changes + 100 mm for the channels. 5) Piping diameter to outdoor unit. Air curtain port connection for all sizes is 1/2" (12,7 mm) / 7/8" (22,00 mm). For smaller models, field-supplied adapters are required to ensure proper pipe connection.

**Accessories**

**PAW-CDP1** Drain pump kit

**Technical focus**

- Advanced defrost control maintains the air curtain effect without cold drafts
- Four air curtain lengths available: P2 and P3 – 1,0 m, 1,5 m, 2,0 m, and 2,5 m
- Installation height up to 3,2 m
- Flexible installation: suspended as standard, cassette or built-in optional\*
- Includes one user-friendly touchscreen remote controller
- Effortless settings management via touchscreen control
- Optional smart temperature control automatically adjusts to outdoor conditions
- Integrated control with door sensor and BMS ON / OFF functionality
- Scalable setup: group up to 10 units for synchronized operation
- Drain pump optional

\*Cassette type (PAW-M2-100/150/200/250GVP) or built-in type (PAW-M3-100/150/200/250BVP) available upon request.

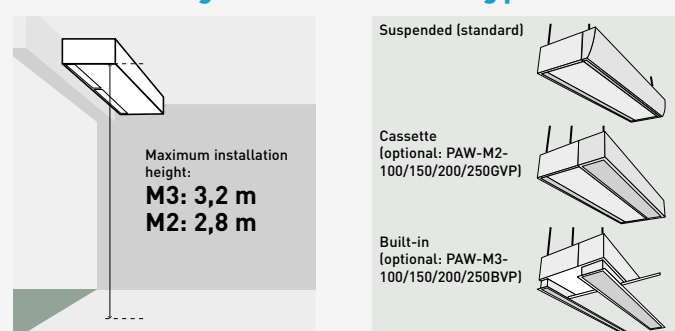
**Installation heights and three mounting possibilities**



**Ceiling mounted air-e nanoe X Generator**

- nanoe™ X technology (Generator Mark 1: 4,8 trillion hydroxyl radicals/sec)
- Silent operation. Whisper quiet at 25,5 dB(A) (at 230 V)
- Low power consumption 4 W
- Easy installation
- Compact and modern design

Model	FV-15CSD1G					
Power supply	Voltage	V	220	230	240	
	Frequency	Hz	50	50	50	
Air flow	m³/h		15	16	17	
	CFM		8,8	9,4	10,0	
Consumption	W		4	4	4	
Sound pressure	dB(A)		23,5	25,5	27,0	
Net weight	kg			1,1		

\*The value of air volume, power consumption and noise are specified at static pressure 0 Pa. The value of air volume is the mean value and a tolerance of +10% is allowed. The value of noise level is a weighted average sound pressure level, the mean value is measured by Panasonic. A tolerance of +3 dB/-7 dB is allowed. The noise is measure at 1 m apart from the left, the front and below of the tested product. Conditions of generating nanoe™ X: room temperature: about 5 °C - 40 °C (dew point temperature more than 2 °C), relative humidity: about 30% - 85%. nanoe™ X is generated using the air in the room, and its amount is subject to the temperature and humidity in the air.

**One device is suitable for around 10 m² (with a ceiling height 3 m)**

Ex. 3 air-e devices are required for the room size 30 m².

The air-e is a stand alone device which is an easy and simple choice to improve indoor air quality. It can be easily installed to various commercial projects including refurbishments.

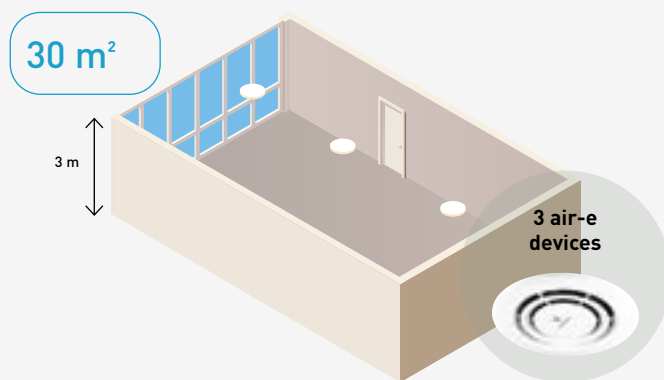

Ceiling mounted air-e nanoe X Generator. Bringing nature's balance indoors with Panasonic's unique nanoe™ X technology built into the air-e. Deodorises and inhibits certain bacteria, viruses, mould, pollens and allergens for better indoor air quality.

**The tested effects of nanoe™ X**

**Bacteria and viruses.**

SARS-CoV-2: 99,9% % inhibited <sup>1)</sup>.  
 Influenza virus H1N1 subtype: 99,9% inhibited <sup>2)</sup>.

**Odour.**

nanoe X Generator can reduce cigarette smoke odour intensity by 2,4 levels in 12 minutes.

- 1) Novel coronavirus [SARS-CoV-2] > [Test organization] Texcell (France) [Test subject] Adhered novel coronavirus [SARS-CoV-2] [Test volume] 45 L enclosed box [Test result] Inhibited 99,9% in 2 hours [Test report] 1140-01 A1.
- 2) Adhered virus [Influenza virus H1N1 subtype] > [Test organization] Kitasato Research Center for Environmental Science [Test subject] Influenza virus [H1N1 subtype] [Test volume] 1000 L enclosed box [Test result] Inhibited 99,9% in 2 hours [Test report] 21\_0084\_1.
- 3) Deodorisation effect for adhering odour (cigarette smoke) > [Test organization] Panasonic Product Analysis Center [Test subject] Adhered cigarette smoke odour [Test volume] Approx. 24 m³ laboratory [Test result] Odour intensity reduced 2,4 levels in 0,2 hours [Test report] 4AA33-160615-N04.

Performance of nanoe™ X might differ in real life environment and is only expected in the same room as where the unit is placed. The nanoe™ X performance varies depending on the room size, environment and usage and it may take several hours to reach the full effect. nanoe™ X is not a medical device.



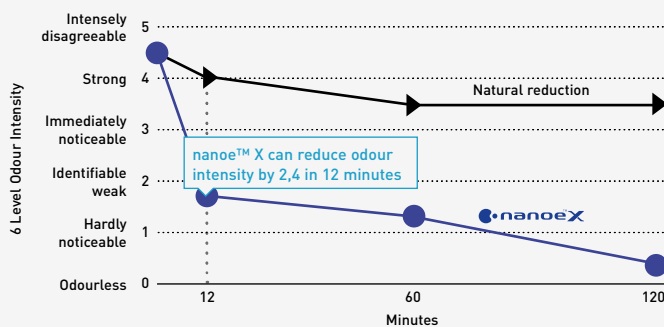











Deodorisation effect for adhering odour (cigarette smoke) <sup>3)</sup>.





For further details and validation data, please refer to the following website.



# ECOi compatible models

Indoor units	U2 type 4 way 90x90 cassette	Y3 type 4 way 60x60 cassette	L1 type 2 way cassette	D1 type 1 way cassette	F3 type adaptive duct	M2 type slim duct	E2 type high static pressure hide- away	K3 type wall- mounted	T2 type ceiling	G1 type floor console	P2 type floor standing	R2 type concealed floor standing	Hydrokit water at 45 °C	Water heat exchanger
														
	R32/ R410A	R32/ R410A	R410A	R410A	R32/ R410A	R32/ R410A	R410A	R32/ R410A	R410A	R410A	R32/ R410A	R32/ R410A	R410A	R410A
Outdoor units	S-**MU2E5C	S-**MY3E8	S-**ML1E5	S-**MD1E5	S-**MF3E5D	S-**MM2E8	S-**ME2E5	S-**MK3E	S-**MT2E5A	S-**MG1E5N	S-**MP2E	S-**MR2E	S-**MW1E5	PAW-**WIPJ5G
R32	LZ2	U- <b>LZ2E5/8</b>	✓	✓			✓	✓				✓	✓	
	MZ1	U- <b>MZ1E8</b>	✓	✓			✓	✓				✓	✓	
	MF4	U- <b>MF4E8</b>	✓	✓			✓	✓				✓	✓	
R410A	LE2	U- <b>LE2E5/8</b>	✓	✓	✓	✓	✓	✓	✓	✓	✓	✓	✓	
	LE1	U- <b>LE1E8</b>	✓	✓	✓	✓	✓	✓	✓	✓	✓	✓	✓	
	ME2	U- <b>ME2E8</b>	✓	✓	✓	✓	✓	✓	✓	✓	✓	✓	✓	✓
	MF3	U- <b>MF3E8</b>	✓	✓	✓	✓	✓	✓	✓	✓	✓	✓	✓	✓

Ventilation	HRPT Series Energy recovery ventilation with DX coil	AHU connection kit		Air curtain with DX coil
				
	R32/R410A	R32/R410A	R410A	R32/R410A
Outdoor units	PAW-HRPT** PAW-HRPT**HX	PAW-P+100MAH4M	PAW-**MAH3M	PAW-M2-***R PAW-M3-***R
R32	LZ2	U- <b>LZ2E5/8</b>	✓	✓
	MZ1	U- <b>MZ1E8</b>	✓	✓
	MF4	U- <b>MF4E8</b>		
R410A	LE2	U- <b>LE2E5/8</b>	✓	✓
	LE1	U- <b>LE1E8</b>	✓	✓
	ME2	U- <b>ME2E8</b>	✓	✓
	MF3	U- <b>MF3E8</b>	✓	✓

# Accessories and control

## R32 ECOi / ECOi EX: Safety measures and accessories



**Leak detector for 4 way 90x90 cassette, 4 way 60x60 cassette, and wall-mounted units.**

-----  
CZ-CGLSC2



**R32 refrigerant leak alarm designed for adaptive duct, slim duct, floor standing and concealed floor standing.**

-----  
CZ-CGLALC1



**2-pipe safety valve kit.**

-----  
CZ-P1160SVK

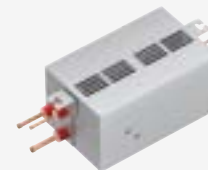

**3-pipe heat recovery box with safety valve kit.**

-----  
CZ-P1160SVHR



**3-pipe heat recovery box.**

-----  
CZ-P1160HR4



**External 16 V power supply.**

-----  
PAW-16DC-ALC1



**Basic Pump Down system (2 way) for one R32 Mini ECOi outdoor unit.**

-----  
PAW-PUD2WB-1

Representative code

## R410A ECOi EX: Heat recovery box

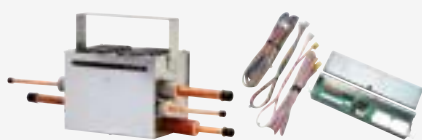

**3-Pipe control Solenoid valve kit (up to 5,6 kW).**

CZ-P56HR3 + CZ-CAPE2.

-----  
KIT-P56HR3



**Solenoid valve kit (up to 5,6 kW).**

-----  
CZ-P56HR3

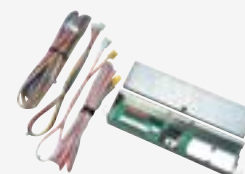

**3-Pipe control PCB.**

-----  
CZ-CAPE2

**3-Pipe control Solenoid valve kit (from 5,6 to 16,0 kW).**

CZ-P160HR3 + CZ-CAPE2.

-----  
KIT-P160HR3

**Solenoid valve kit (from 5,6 kW to 16,0 kW).**

-----  
CZ-P160HR3

**3-Pipe control PCB for wall-mounted.**

-----  
CZ-CAPEK2

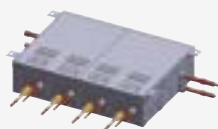

**4 ports 3 pipe box (up to 5,6 kW per port).**

-----  
CZ-P456HR3

**4 ports 3 pipe box (up to 16,0 kW per port).**

-----  
CZ-P4160HR3

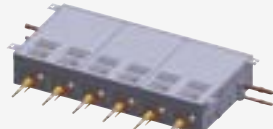

**6 ports 3 pipe box (up to 5,6 kW per port).**

-----  
CZ-P656HR3

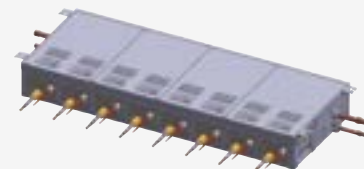

**8 ports 3 pipe box (up to 5,6 kW per port).**

-----  
CZ-P856HR3

## Leak detection and automatic Pump Down for R410A refrigerant



<b>Pump Down system (2 way) for 1 outdoor unit.</b>	<b>Pump Down system (2 way) for 2 outdoor units.</b>	<b>Pump Down system (2 way) for 3 outdoor units.</b>
PAW-PUD2W-1R	PAW-PUD2W-2R	PAW-PUD2W-3R <sup>1)</sup>
<b>Pump Down system (3 way) for 1 outdoor unit.</b>	<b>Pump Down system (3 way) for 2 outdoor units.</b>	<b>Pump Down system (3 way) for 3 outdoor units.</b>
PAW-PUD3W-1R	PAW-PUD3W-2R	PAW-PUD3W-3R <sup>1)</sup>









<sup>1)</sup>Special order requiring the longer lead time than usual. For the detailed information, please contact an authorized Panasonic dealer.

## Distribution joint kits

<b>2-Pipe MZ1/ME2 for outdoor units (up to 68,0 kW).</b>	<b>2-Pipe MZ1/ME2 for outdoor units (from 68,0 kW to 168,0 kW).</b>	<b>2-Pipe MZ1/ME2 and Mini ECOi for indoor units (up to 22,4 kW<sup>2)</sup>).</b>
CZ-P680PH2BM	CZ-P1350PH2BM	CZ-P224BK2BM
<b>2-Pipe MZ1/ME2 for indoor units (from 22,4 kW to 68,0 kW<sup>2)</sup>).</b>	<b>2-Pipe MZ1/ME2 for indoor units (from 68,0 kW to 168,0 kW<sup>2)</sup>).</b>	<b>3-Pipe MF4/MF3 for outdoor units (up to 68,0 kW).</b>
CZ-P680BK2BM	CZ-P1350BK2BM	CZ-P680PJ2BM
<b>3-Pipe MF4/MF3 for outdoor units (from 68,0 kW to 135,0 kW).</b>	<b>3-Pipe MF4/MF3 for indoor units (up to 22,4 kW).</b>	<b>3-Pipe MF4/MF3 for indoor units (from 22,4 kW to 68,0 kW).</b>
CZ-P1350PJ2BM	CZ-P224BH2BM	CZ-P680BH2BM
<b>3-Pipe MF4/MF3 for indoor units (up to 68,0 kW).</b>	<b>2-Pipe MZ1/ME2 header pipe.</b>	<b>3-Pipe MF4/MF3 header pipe.</b>
CZ-P1350BH2BM	CZ-P4HP4C2BM	CZ-P4HP3C2BM

<sup>2)</sup>In case the total capacity of indoor units connected after distribution exceeds the total capacity of the outdoor units, select the distribution piping size for the total capacity of the outdoor units.

## Panels

			
<b>Standard panel for 4 way 90x90 cassette, white (RAL9003).</b>	<b>Econavi panel for 4 way 90x90 cassette, white (RAL9003).</b>	<b>Standard panel for 4 way 90x90 cassette, graphite black (RAL9011).</b>	<b>NEW! Panel for 4 way 60x60 cassette, white (RAL9003).</b>
CZ-KPU3	CZ-KPU3A	CZ-KPU3B	CZ-KPY4W
			
<b>NEW! Panel for 4 way 60x60 cassette, graphite black (RAL9011).</b>	<b>Panel for 2 way cassette (for S-22 to S-56 models).</b>	<b>Panel for 2 way cassette (for S-73 model).</b>	<b>Panel for 1 way cassette.</b>
CZ-KPY4B	CZ-02KPL2	CZ-03KPL2	CZ-KPD2

<sup>1)</sup>Available in Autumn 2026.

**Sensors**



**Econavi energy saving sensor.**

-----  
CZ-CENSC1



**Remote temperature sensor.**

-----  
CZ-CSRC3

**Cassette fresh air-intake kit.**

-----  
CZ-FDU3+CZ-ATU2

**IAQ filter for adaptive ducted unit**



\*Tentative image.

**BION air pollutant filter for MF3 15, 22, 28, 36, 45 and 56.**

-----  
PAW-APF800F

**BION air pollutant filter for MF3 60 and 73.**

-----  
PAW-APF1000F

**BION air pollutant filter for MF3 90, 112, 140 and 160.**

-----  
PAW-APF1400F

**Plenums**

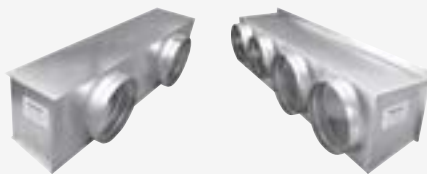

**Air outlet plenum for MF3 15, 22, 28, 36, 45 and 56.**

-----  
CZ-56DAF2

**Air outlet plenum for MF3 60, 73 and 90.**

-----  
CZ-90DAF2

**Air outlet plenum for MF3 106, 112, 140 and 160.**

-----  
CZ-160DAF2

**Air outlet plenum for S-224ME1E5.**

-----  
CZ-TREMIESPW705

**Air outlet plenum for S-280ME1E5.**

-----  
CZ-TREMIESPW706

**Valves**



**Wall-mounted external valve for model sizes 15 to 73.**

-----  
CZ-P73SVK3<sup>3)</sup>

**Wall-mounted external valve for model size 106.**















-----  
CZ-P106SVK3

**Rap valve kit.**

-----  
CZ-P160RVK2

\*A 3/8" to 1/4" reducer is required when combining the S-73MK3E with ECoI EX R410A outdoor units (ME2 and MF3).

Individual controls

 <p><b>CONEX wired remote controller (non-wireless), white.</b></p> <p>----- CZ-RTC6W</p>	 <p><b>CONEX wired remote controller with Bluetooth®, white.</b></p> <p>----- CZ-RTC6WBL</p>	 <p><b>CONEX wired remote controller with Wi-Fi and Bluetooth®, white.</b></p> <p>----- CZ-RTC6WBLW2*</p>	 <p><b>CONEX wired remote controller (non-wireless), black.</b></p> <p>----- CZ-RTC6</p>
 <p><b>CONEX wired remote controller with Bluetooth®, black.</b></p> <p>----- CZ-RTC6BL</p>	 <p><b>CONEX wired remote controller with Wi-Fi and Bluetooth®, black.</b></p> <p>----- CZ-RTC6BLW2*</p>	 <p><b>Design wired remote controller with Econavi function.</b></p> <p>----- CZ-RTC5B</p>	 <p><b>Infrared remote controller and receiver for 4 way 60x60 cassette with panel.</b></p> <p>----- CZ-RWS3 + CZ-RWRY3W</p>
 <p><b>Infrared remote controller and receiver for 4 way 90x90 cassette.</b></p> <p>----- CZ-RWS3 + CZ-RWRU3</p>	 <p><b>Infrared remote controller and receiver for 2 way cassette.</b></p> <p>----- CZ-RWS3 + CZ-RWRL3</p>	 <p><b>Infrared remote controller and receiver for 1 way cassette.</b></p> <p>----- CZ-RWS3 + CZ-RWRD3</p>	
 <p><b>Infrared remote controller and receiver for ceiling.</b></p> <p>----- CZ-RWS3 + CZ-RWRT3</p>	 <p><b>Infrared remote controller for wall-mounted and floor console.</b></p> <p>----- CZ-RWS3</p>	 <p><b>Infrared remote controller and receiver for all indoor units.</b></p> <p>----- CZ-RWS3 + CZ-RWRC3</p>	

\*Available for indoor unit types MY3, MF3, MM2, and MK3.

**Controller and touch controllers for hotels with dry contacts**



**Modbus RS-485 touch room controller with I/O, white.**

PAW-RE2C4-MOD-WH

**Touch display control with 2 digital inputs, white.**

PAW-RE2D4-WH



**Modbus RS-485 touch room controller with I/O, black.**

PAW-RE2C4-MOD-BK

**Touch display control with 2 digital inputs, black.**

PAW-RE2D4-BK

**Hotel sensors for dry contacts**



**Wall silent motion sensor 24 V.**

PAW-WMS-DC

**Wall silent motion sensor 240 V AC.**

PAW-WMS-AC



**Ceiling silent motion sensor 24 V.**

PAW-CMS-DC

**Ceiling silent motion sensor 240 V AC.**

PAW-CMS-AC



**Power supply 24 V.**

PAW-24DC



**Door or window contact.**

PAW-DWC

**Centralised controls**



**System controller for 64 indoor units with weekly timer.**

CZ-64ESMC3



**Central ON / OFF controller, up to 16 groups, 64 indoor units.**

CZ-ANC3



**Intelligent controller (touch screen/web server) to control up to 256 indoors with included load distribution ratio (LDR).**

CZ-256ESMC3

**Commercial Smart Edge**



**Gateway for Commercial Smart Edge – supports up to 4 indoor unit connections.**

PAW-CSE-1B

**Gateway for Commercial Smart Edge – supports up to 10 indoor unit connections.**

PAW-CSE-2B

**Gateway for Commercial Smart Edge – supports up to 50 indoor unit connections.**

PAW-CSE-10

**Gateway for Commercial Smart Edge – supports up to 100 indoor unit connections.**

PAW-CSE-20

\*The final number of connected indoor units may vary depending on the range. \*\*For the detail information, please contact an authorised Panasonic dealer.

**BMS interface with S-Link**



**A unified interface supporting Modbus, BACnet, and KNX protocols for up to 16 indoor units.**

PAW-AC2-BMS-16

**A unified interface supporting Modbus, BACnet, and KNX protocols for up to 64 indoor units.**

PAW-AC2-BMS-64

**A unified interface supporting Modbus, BACnet, and KNX protocols for up to 128 indoor units.**

PAW-AC2-BMS-128

**Accessories interfaces**



**Commercial Wi-Fi Adaptor.**

CZ-CAPWFC2



**DIN rail-mounted KNX interface.**

PAW-RC2-KNX-1i



**DIN rail-mounted Modbus RTU interface.**

PAW-RC2-MBS-1



**Modbus RTU interface to control 4 indoor/groups.**

PAW-RC2-MBS-4



**BACnet IP and MSTP.**

PAW-RC2-BAC-1



**KNX interface.**

PAW-AZRC-KNX-1



**Modbus RTU interface with 12 V DC power supply.**

PAW-AZRC-MBS-1



**BACnet IP and MSTP interface.**

PAW-AZRC-BAC-1



**RAC interface adapter for integration into S-Link, plus external input and alarm/status output.**

CZ-CAPRA1

**Centralised controls. Connection with general equipment**



**Adaptor for ON / OFF control of external devices. Up to three digital outputs.**

-----  
CZ-CAPC4



**Demand control for Mini ECOi (LZ2, LE2).**

-----  
CZ-CAPDC3



**Mini series parallel device controlling indoor units, maximum 1 group and 8 indoor unit.**

-----  
CZ-CAPBC2



**Communication Adaptor. Up to 128 groups. Controls 128 units.**

-----  
CZ-CFUNC2

**Accessories PCB and cables**



**T10 interface PCB with digital and relay connections.**

-----  
PAW-T10



**Cable for all the T10 functions.**

-----  
CZ-T10



**Cable to operate external fan.**

-----  
PAW-FDC



**Cable for all option monitoring signals.**

-----  
PAW-OCT

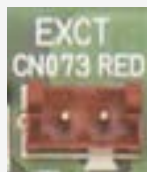

**Cable with force thermo OFF/leakage detection.**

-----  
PAW-EXCT



**Option harness for PAW-OCT and PAW-FDC, providing option, fan drive, and EXCT functions. For VRF indoor units MM2, MK3, MP2, and MR2.**

-----  
PAW-OPT-MZ

**R-22 Replacement Kit**

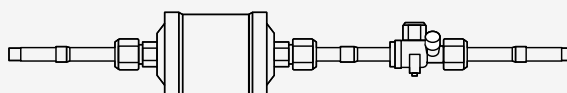

**Replacement kit for R-22.**

-----  
CZ-SLK2

**Water heat exchanger accessories**

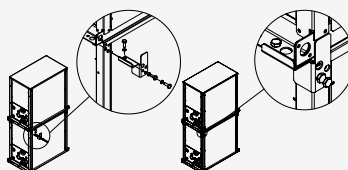

**Stacking kit for vertically stacking up to 3 WHE (4 pieces per Kit).**

-----  
PAW-3WSK

# Dimension and tube sizes of branches and headers for 2-Pipe ECOi EX ME2 and Mini ECOi Series

## Optional distribution joint kits.

See the installation instructions packaged with the distribution joint kit for the installation procedure.

\*In case the total capacity of indoor units connected after distribution exceeds the total capacity of the outdoor units, select the distribution piping size for the total capacity of the outdoor units.

Model name	Cooling capacity after distribution	Remarks
1. CZ-P680PH2BM	Up to 68,0 kW	For outdoor unit
2. CZ-P1350PH2BM	From 68,0 kW to 168,0 kW	For outdoor unit
3. CZ-P224BK2BM*	Up to 22,4 kW	For indoor unit
4. CZ-P680BK2BM*	From 22,4 kW to 68,0 kW	For indoor unit
5. CZ-P1350BK2BM*	From 68,0 kW to 168,0 kW	For indoor unit

## Tube size (with thermal insulation)

1. CZ-P680PH2BM: For outdoor unit side (capacity after distribution joint up to 68,0 kW).

Gas piping

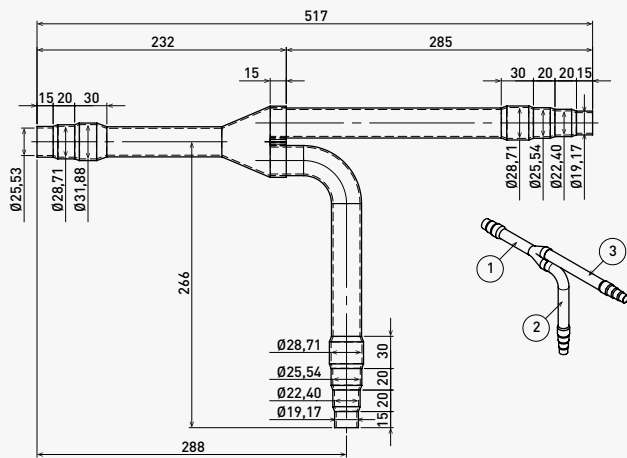

Liquid piping

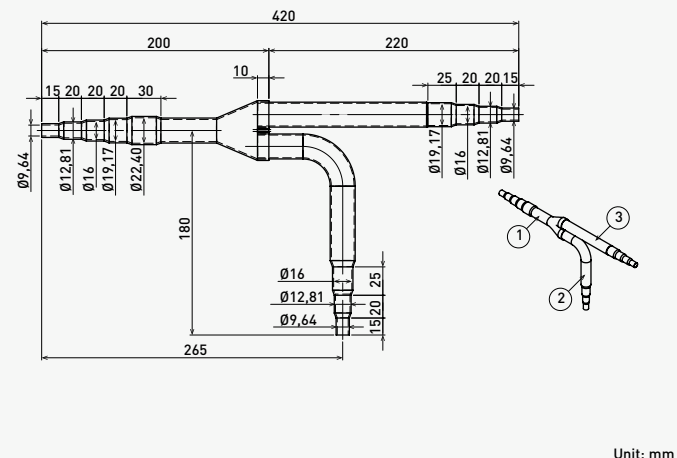

Unit: mm

2. CZ-P1350PH2BM: For outdoor unit side (capacity after distribution joint is from 68,0 kW to 168,0 kW).

Gas piping

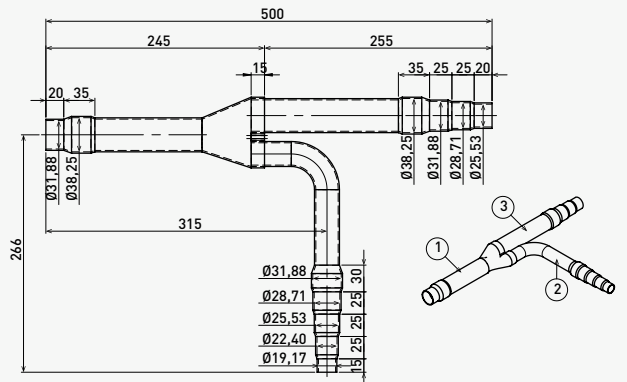

Liquid piping

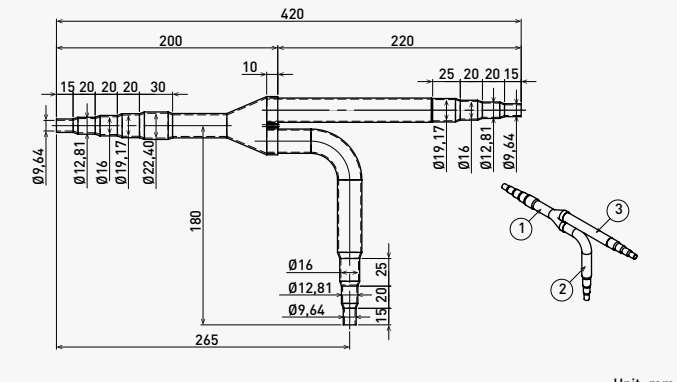

Unit: mm

3. CZ-P224BK2BM: For indoor unit side (capacity after distribution joint up to 22,4 kW).

Gas piping

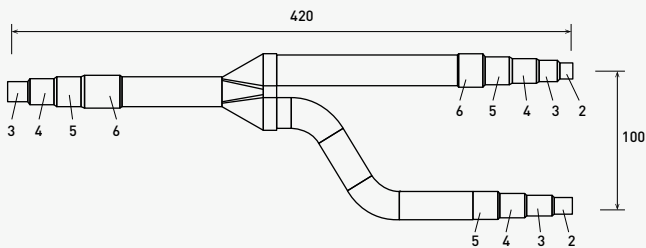

Liquid piping

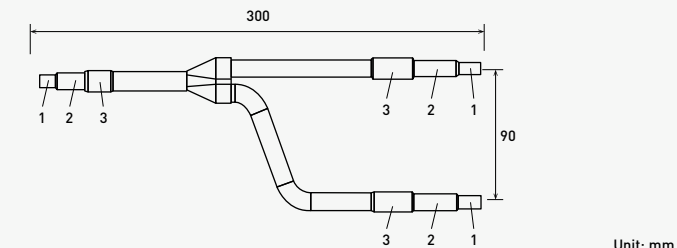

Unit: mm

**4. CZ-P680BK2BM:** For indoor unit side (capacity after distribution joint is from 22,4 kW to 68,0 kW).

Gas piping

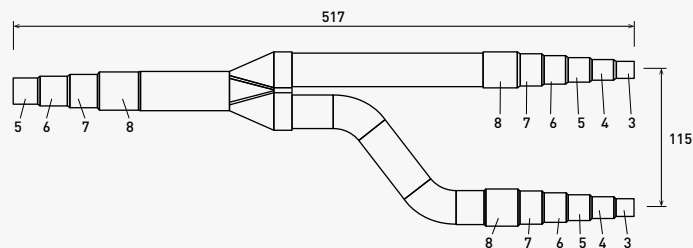

Liquid piping

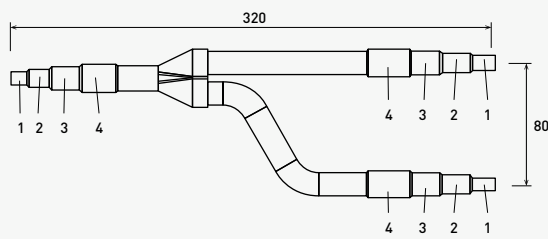

Unit: mm

**5. CZ-P1350BK2BM:** For indoor unit side (capacity after distribution joint is from 68,0 kW to 168,0 kW).

Gas piping

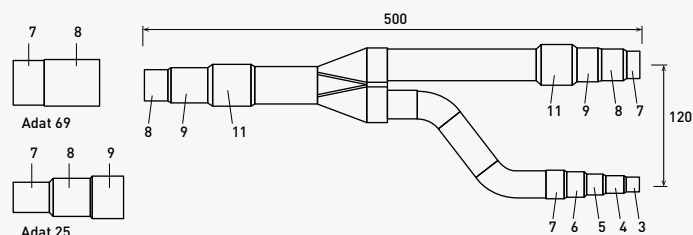

Liquid piping

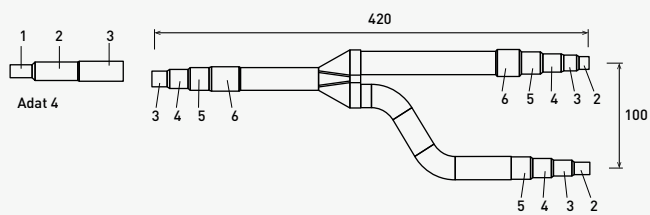

Unit: mm

Size of connection point on each part (shown are inside diameters of piping)

Diameters		1	2	3	4	5	6	7	8	9	10	11	12	13	14
Dimension	Inch	1/4	3/8	1/2	5/8	3/4	7/8	1	1 1/8	1 1/4	1 3/8	1 1/2	1 5/8	1 3/4	2
	mm	6,35	9,52	12,70	15,88	19,05	22,40	25,40	28,57	31,75	34,92	38,10	41,28	44,45	50,80

**Header pipe set**

**CZ-P4HP4C2BM**

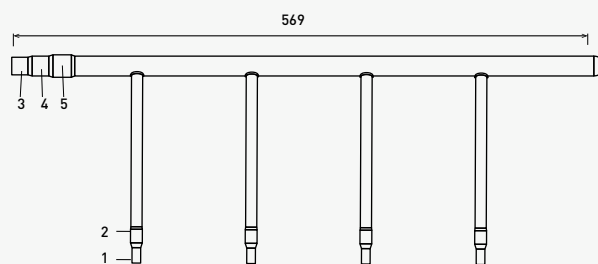
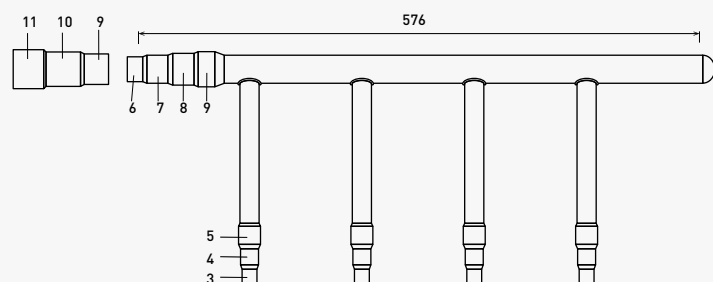

Size of connection point on each part (shown are inside diameters of piping)

Diameters		1	2	3	4	5	6	7	8	9	10	11
Dimension	Inch	1/4	3/8	1/2	5/8	3/4	7/8	1	1 1/8	1 1/4	1 3/8	1 1/2
	mm	6,35	9,52	12,70	15,88	19,05	22,40	25,40	28,57	31,75	34,92	38,10

**Distribution joint Kits for Mini ECOi LE/LZ Series**

**CZ-P224BK2BM:** For indoor unit side (capacity after distribution joint up to 22,4 kW).

Gas piping

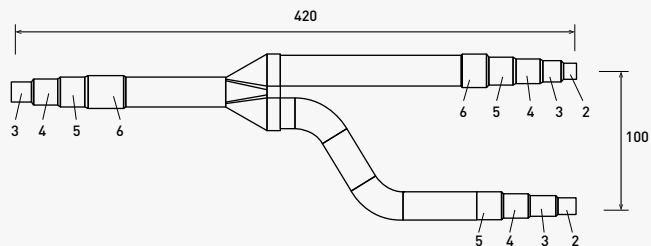

Liquid piping

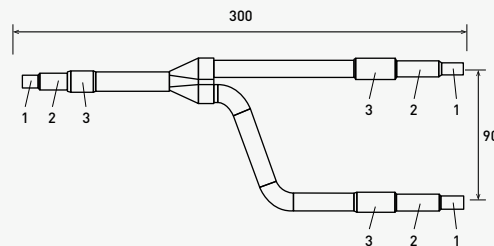

Unit: mm

Size of connection point on each part (shown are inside diameters of piping)

Diameters		1	2	3	4	5	6
Dimension	Inch	1/4	3/8	1/2	5/8	3/4	7/8
	mm	6,35	9,52	12,70	15,88	19,05	22,40

# Dimension and tube sizes of branches and headers for 3-Pipe ECOi EX MF3 Series

## Optional distribution joint kits.

See the installation instructions packaged with the distribution joint kit for the installation procedure.

Model name	Cooling capacity after distribution	Remarks
1. CZ-P680PJ2BM	Up to 68,0 kW	For outdoor unit
2. CZ-P1350PJ2BM	From 68,0 kW to 135,0 kW	For outdoor unit
3. CZ-P224BH2BM	Up to 22,4 kW	For indoor unit
4. CZ-P680BH2BM	From 22,4 kW to 68,0 kW	For indoor unit
5. CZ-P1350BH2BM	From 68,0 kW to 135,0 kW	For indoor unit

## Piping size

1. CZ-P680PJ2BM: For outdoor unit side (capacity after distribution joint up to 68,0 kW).

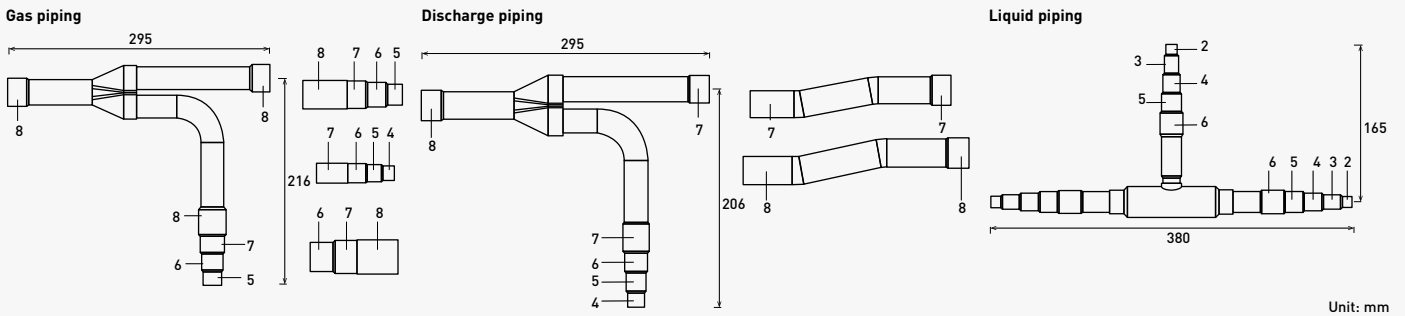

2. CZ-P1350PJ2BM: For outdoor unit side (capacity after distribution joint is from 68,0 kW to 135,0 kW).

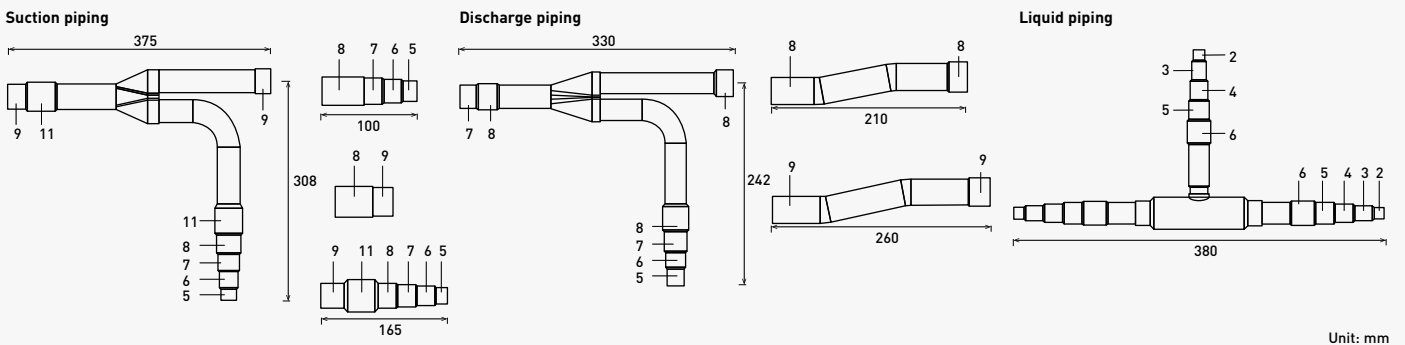

3. CZ-P224BH2BM: For indoor unit side (capacity after distribution joint up to 22,4 kW).

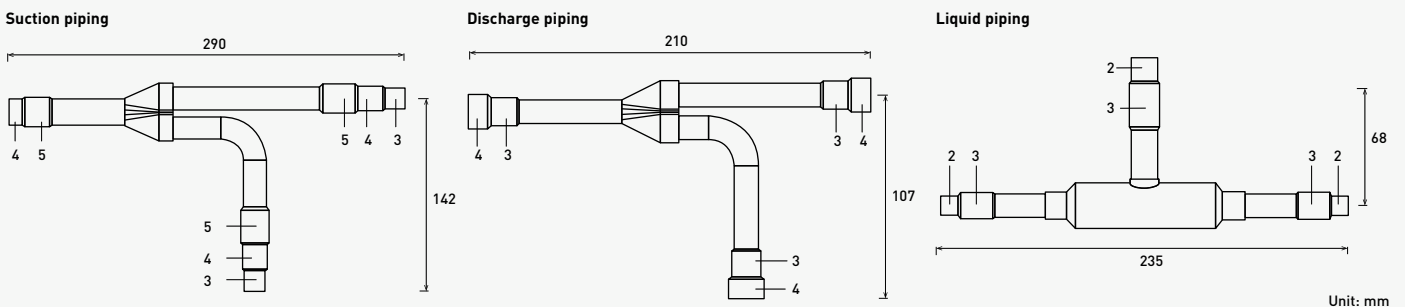

**4. CZ-P680BH2BM:** For indoor unit side (capacity after distribution joint is from 22,4 kW to 68,0 kW).

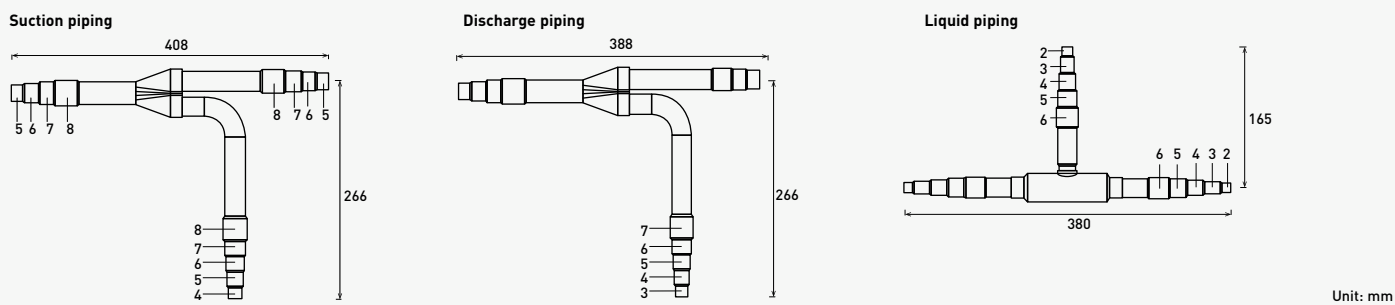

**5. CZ-P1350BH2BM:** For indoor unit side (capacity after distribution joint is from 68,0 kW to 135,0 kW).

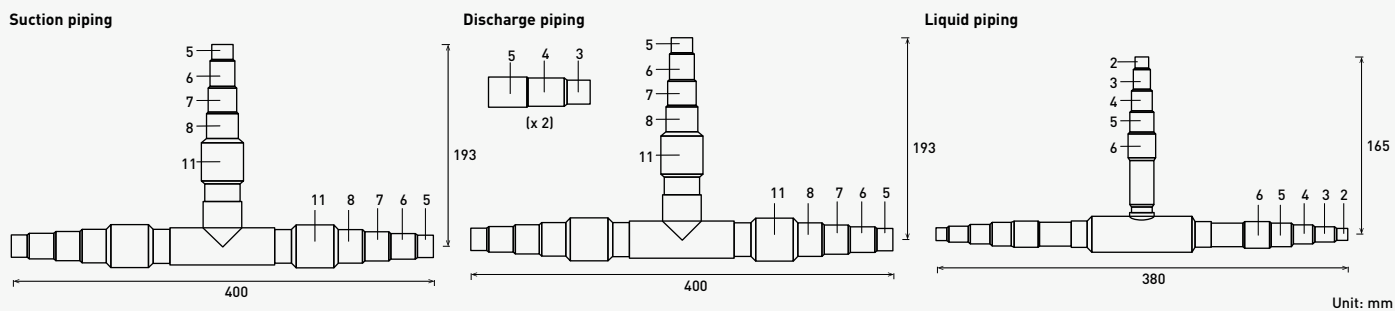

Size of connection point on each part (shown are inside diameters of piping)

Diameters	1	2	3	4	5	6	7	8	9	10	11	12	13	14	
Inch	1/4	3/8	1/2	5/8	3/4	7/8	1	1 1/8	1 1/4	1 3/8	1 1/2	1 5/8	1 3/4	2	
Dimension	mm	6,35	9,52	12,70	15,88	19,05	22,40	25,40	28,57	31,75	34,92	38,10	41,28	44,45	50,80

**Header pipe set**

**CZ-P4HP3C2BM**

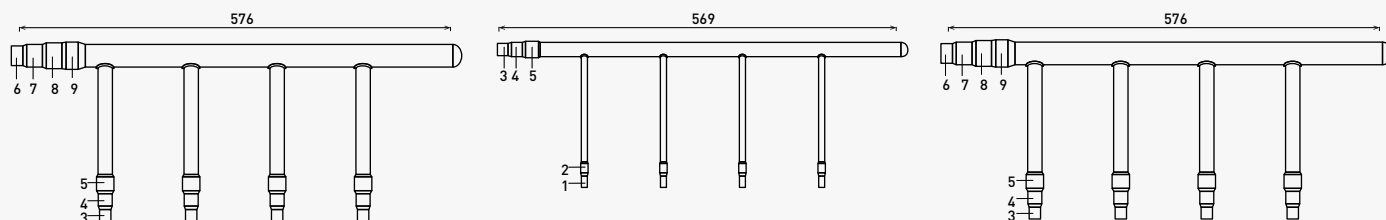

Size of connection point on each part (shown are inside diameters of piping)

Diameters	1	2	3	4	5	6	7	8	9	10	11	
Inch	1/4	3/8	1/2	5/8	3/4	7/8	1	1 1/8	1 1/4	1 3/8	1 1/2	
Dimension	mm	6,35	9,52	12,70	15,88	19,05	22,40	25,40	28,57	31,75	34,92	38,10

## Eurovent certified technical data

Panasonic's PACi and VRF systems are now certified by Eurovent\*.



The Eurovent certification verifies the performance ratings of heating and cooling systems following European standards. Data provides products efficiency with full transparency, for the benefit of customers and professionals.



### Eurovent VRF certified technical data: Mini ECOi LZ2 Series 4 to 10 HP · R32

HP		4 HP				5 HP				6 HP				8 HP		10 HP	
Outdoor unit		U-4LZ2E5		U-4LZ2E8		U-5LZ2E5		U-5LZ2E8		U-6LZ2E5		U-6LZ2E8		U-8LZ2E8		U-10LZ2E8	
Indoor units combination S-**MU2: S-**MU2E5C S-**MF3: S-**MF3E5D		2x S-60MU2	3x S-28MF3	2x S-60MU2	3x S-28MF3	4x S-36MU2	4x S-36MF3	4x S-36MU2	4x S-36MF3	2x S-36MU2	2x S-36MF3	2x S-36MU2	2x S-36MF3	4x S-56MU2	4x S-56MF3	4x S-73MU2	4x S-73MF3
Cooling	Pc out <sup>1)</sup> kW	12,1	12,1	12,1	12,1	14,0	14,0	14,0	14,0	15,5	15,5	15,5	15,5	22,4	19,0	28,0	23,8
	Pec out <sup>2)</sup> kW	3,0	3,6	3,0	3,6	3,7	4,5	3,7	4,5	4,4	5,2	4,4	5,2	6,8	6,8	9,7	9,5
	EERout	4,1	3,4	4,1	3,4	3,8	3,1	3,8	3,1	3,5	3,0	3,5	3,0	3,3	2,8	2,9	2,5
Seasonal Cooling	SEER	8,5	6,8	8,5	6,8	8,1	6,8	8,1	6,8	7,7	6,5	7,7	6,5	7,6	5,8	7,1	5,7
	η <sub>s,c</sub> %	337,0	270,6	337,0	270,6	321,8	267,4	321,8	267,4	305,4	258,2	305,4	258,2	299,4	228,6	280,2	225,8
Cooling PL Condition B	PcB kW	8,9	8,9	8,9	8,9	10,3	10,3	10,3	10,3	11,4	11,4	11,4	11,4	16,5	14,0	20,6	17,5
	EERB	6,5	5,2	6,5	5,2	5,9	4,9	5,9	4,9	5,4	4,7	5,4	4,7	5,2	4,2	4,6	4,0
Cooling PL Condition C	PcC kW	5,7	5,7	5,7	5,7	6,6	6,6	6,6	6,6	7,3	7,3	7,3	7,3	10,6	9,0	13,2	11,2
	EERC	11,3	8,8	11,3	8,8	10,8	9,0	10,8	9,0	10,2	8,8	10,2	8,8	9,6	7,0	8,7	6,7
Cooling PL Condition D	PcD kW	5,4	5,4	5,4	5,4	5,6	5,4	5,6	5,4	5,8	5,4	5,8	5,4	9,0	7,1	9,5	8,0
	EERD	15,6	12,3	15,6	12,3	15,2	12,1	15,2	12,1	15,0	11,0	15,0	11,0	16,6	11,5	18,0	13,1
Seasonal Heating	Pdesign kW	10,0	10,0	10,0	10,0	11,2	11,2	11,2	11,2	11,6	11,6	11,6	11,6	17,5	16,2	19,6	18,2
	SCOP	5,1	4,0	5,1	4,0	4,6	3,9	4,6	3,9	4,6	3,7	4,6	3,7	4,6	3,8	4,6	3,9
	η <sub>s,h</sub> %	199,0	155,8	199,0	155,8	181,4	151,0	181,4	151,0	180,6	146,6	180,6	146,6	180,6	147,4	181,0	151,4
Heating PL Condition A	PhA kW	8,8	8,8	8,8	8,8	9,9	9,9	9,9	9,9	10,3	10,3	10,3	10,3	15,4	14,3	17,3	16,1
	COPA	3,1	2,5	3,1	2,5	2,9	2,4	2,9	2,4	2,9	2,3	2,9	2,3	2,9	2,4	2,8	2,3
Heating PL Condition B	PhB kW	5,4	5,4	5,4	5,4	6,0	6,0	6,0	6,0	6,2	6,2	6,2	6,2	9,4	8,7	10,5	9,8
	COPB	4,8	3,6	4,8	3,6	4,1	3,4	4,1	3,4	4,1	3,3	4,1	3,3	4,2	3,5	4,2	3,6
Heating PL Condition C	PhC kW	3,5	3,5	3,5	3,5	3,9	3,9	3,9	3,9	4,0	4,0	4,0	4,0	6,2	5,6	6,7	6,3
	COPC	7,2	6,1	7,2	6,1	7,2	6,2	7,2	6,2	7,1	6,1	7,1	6,1	6,9	5,4	7,1	5,8
Heating PL Condition D	PhD kW	4,0	3,5	4,0	3,5	4,0	3,5	4,0	3,5	4,0	3,5	4,0	3,5	6,7	6,0	6,9	6,2
	COPD	9,1	7,4	9,1	7,4	9,3	7,3	9,3	7,3	9,3	7,3	9,3	7,3	8,7	6,8	9,2	7,2
T bivalent	Tbiv °C	-10	-7	-10	-7	-7	-7	-7	-7	-7	-7	-7	-7	-7	-7	-7	-7
	PhTbiv kW	10,0	8,8	10,0	8,8	9,9	9,9	9,9	9,9	10,3	10,3	10,3	10,3	15,4	14,3	17,3	16,1
	COPTbiv	2,5	2,5	2,5	2,5	2,9	2,4	2,9	2,4	2,9	2,4	2,9	2,4	2,9	2,4	2,8	2,3
PsbC	W	14,0	14,0	14,0	14,0	14,0	14,0	14,0	14,0	14,0	14,0	14,0	14,0	18,0	18,0	18,0	18,0
Psbh	W	14,0	14,0	14,0	14,0	14,0	14,0	14,0	14,0	14,0	14,0	14,0	14,0	18,0	18,0	18,0	18,0
PoffC	W	14,0	14,0	14,0	14,0	14,0	14,0	14,0	14,0	14,0	14,0	14,0	14,0	18,0	18,0	18,0	18,0
Poffh	W	14,0	14,0	14,0	14,0	14,0	14,0	14,0	14,0	14,0	14,0	14,0	14,0	18,0	18,0	18,0	18,0
PtOc	W	18,0	18,0	18,0	18,0	18,0	18,0	18,0	18,0	18,0	18,0	18,0	18,0	26,0	26,0	26,0	26,0
PtOh	W	18,0	18,0	18,0	18,0	18,0	18,0	18,0	18,0	18,0	18,0	18,0	18,0	26,0	26,0	26,0	26,0
PckC	W	18,0	18,0	18,0	18,0	18,0	18,0	18,0	18,0	18,0	18,0	18,0	18,0	26,0	26,0	26,0	26,0
Pckh	W	18,0	18,0	18,0	18,0	18,0	18,0	18,0	18,0	18,0	18,0	18,0	18,0	26,0	26,0	26,0	26,0
Sound power level / in heating	dB(A)	69 / 72	—	69 / 72	—	70 / 74	—	70 / 74	—	72 / 75	—	72 / 75	—	72 / 74	—	74 / 75	—

### Eurovent VRF certified technical data: 2-Pipe ECOi EX MZ1 Series 8 to 12 HP · R32

HP		8 HP			10 HP		12 HP	
Outdoor unit		U-8MZ1E8		U-10MZ1E8		U-12MZ1E8		
Indoor units combination S-**MU2: S-**MU2E5C S-**MF3: S-**MF3E5D		4x S-56MU2		4x S-56MF3		4x S-73MU2		
Cooling	Pc out <sup>1)</sup> kW	22,40	18,10	28,00	22,70	33,50	27,20	
	Pec out <sup>2)</sup> kW	6,78	6,70	8,00	8,11	11,17	11,33	
	EERout	3,30	2,70	3,50	2,80	3,00	2,40	
Seasonal Cooling	SEER	7,27	5,20	7,82	5,62	7,37	5,30	
	η <sub>s,c</sub> %	288,00	205,10	310,10	221,80	292,10	209,20	
Cooling PL Condition B	PcB kW	16,50	13,80	20,60	17,20	24,70	20,70	
	EERB	5,10	3,90	5,30	4,10	4,80	3,70	
Cooling PL Condition C	PcC kW	10,60	8,60	13,30	10,80	15,90	13,00	
	EERC	9,10	6,10	9,60	6,50	8,90	6,00	
Cooling PL Condition D	PcD kW	9,30	8,00	9,80	8,40	10,10	8,70	
	EERD	16,30	10,50	18,40	11,80	19,60	12,70	
Seasonal Heating	Pdesign kW	16,30	13,20	20,50	16,50	24,40	19,80	
	SCOP	4,35	3,57	4,38	3,57	4,33	3,61	
	η <sub>s,h</sub> %	171,00	140,10	172,40	139,80	170,30	141,60	
Heating PL Condition A	PhA kW	14,40	13,20	18,10	16,50	21,60	19,80	
	COPA	2,80	2,30	2,70	2,30	2,40	2,10	
Heating PL Condition B	PhB kW	8,70	7,90	11,00	9,90	13,10	11,90	
	COPB	4,10	3,50	4,00	3,30	4,00	3,40	
Heating PL Condition C	PhC kW	5,90	5,40	7,10	6,50	8,40	7,80	
	COPC	6,10	5,00	6,60	5,40	7,00	5,80	
Heating PL Condition D	PhD kW	6,90	6,90	7,40	7,40	8,80	6,80	
	COPD	7,50	6,80	8,50	7,70	8,20	7,50	
T bivalent	Tbiv °C	-10	-7	-10	-7	-10	-7	
	PhTbiv kW	16,30	13,20	20,50	16,50	24,40	19,80	
	COPTbiv	2,40	2,30	2,40	2,30	2,10	2,10	
PsbC	W	15,00	15,00	15,00	15,00	15,00	15,00	
Psbh	W	15,00	15,00	15,00	15,00	15,00	15,00	
PoffC	W	1,00	1,00	1,00	1,00	1,00	1,00	
Poffh	W	34,00	34,00	34,00	34,00	34,00	34,00	
PtOc	W	24,00	24,00	24,00	24,00	24,00	24,00	
PtOh	W	23,00	23,00	23,00	23,00	23,00	23,00	
PckC	W	23,00	23,00	23,00	23,00	23,00	23,00	
Pckh	W	37,00	37,00	37,00	37,00	37,00	37,00	
Sound power level / in heating	dB(A)	75 / 75	75 / 75	77 / 77	77 / 77	81 / 84	81 / 84	

## Eurovent VRF certified technical data

## Eurovent VRF certified technical data: Mini ECOi LE Series 4 to 10 HP - R410A

HP	4 HP				5 HP				6 HP				8 HP		10 HP		
Outdoor unit	U-4LE2E5		U-4LE2E8		U-5LE2E5		U-5LE2E8		U-6LE2E5		U-6LE2E8		U-8LE1E8		U-10LE1E8		
Indoor units combination	3x	3x	3x	3x	4x	4x	4x	4x	2x	2x	2x	2x	4x	4x	4x	4x	
S-***MU2: S-***MU2E5C	S-28MU2	S-28MF2	S-28MU2	S-28MF2	S-36MU2	S-36MF2	S-36MU2	S-36MF2	S-36MU2	S-36MF2	S-36MU2	S-36MF2	S-36MU2	S-56MU2	S-56MF2	S-73MU2	S-73MF2
S-***MF2: S-***MF2E5A	1x	1x	1x	1x	1x	1x	1x	1x	2x	2x	2x	2x	2x	2x	2x	2x	2x
	S-36MU2	S-36MF2	S-36MU2	S-36MF2					S-45MU2	S-45MF2	S-45MU2	S-45MF2					
Cooling	Pc out <sup>1)</sup> kW	12,1	12,1	12,1	12,1	14,0	14,0	14,0	14,0	15,5	15,5	15,5	15,5	22,4	22,4	28,0	28,0
	Pec out <sup>2)</sup> kW	2,9	2,9	2,9	2,9	3,7	3,7	3,7	3,7	4,6	4,6	4,6	4,6	7,2	7,2	10,8	10,8
	EERout	4,2	4,2	4,2	4,2	3,8	3,8	3,8	3,8	3,4	3,4	3,4	3,4	3,1	3,1	2,6	2,6
Seasonal Cooling	SEER	7,8	7,8	7,8	7,8	7,5	7,5	7,5	7,5	7,2	7,2	7,2	7,2	6,3	6,3	6,4	6,4
	η <sub>sc</sub> %	311,0	309,0	311,0	309,0	296,2	297,0	296,2	297,0	286,8	285,0	286,8	285,0	247,9	249,0	251,8	253,0
Cooling PL Condition B	PcB kW	8,9	8,9	8,9	8,9	10,3	10,3	10,3	10,3	11,4	11,4	11,4	11,4	16,5	16,5	20,6	20,6
	EERB	6,7	6,7	6,7	6,7	6,0	6,0	6,0	6,0	5,5	5,5	5,5	5,5	4,8	4,8	4,4	4,4
Cooling PL Condition C	PcC kW	5,7	5,7	5,7	5,7	6,6	6,6	6,6	6,6	7,3	7,3	7,3	7,3	10,6	10,6	13,2	13,2
	EERC	12,2	12,2	12,2	12,2	11,2	11,2	11,2	11,2	10,1	10,1	10,1	10,1	7,8	7,8	8,2	8,2
Cooling PL Condition D	PcD kW	2,6	2,6	2,6	2,6	2,9	2,9	2,9	2,9	3,4	3,4	3,4	3,4	8,0	8,0	9,0	9,0
	EERD	10,0	10,0	10,0	10,0	10,2	10,2	10,2	10,2	12,1	12,1	12,1	12,1	12,8	12,8	15,4	15,4
Seasonal Heating	Pdesign kW	10,0	10,0	10,0	10,0	12,5	12,5	12,5	12,5	13,0	13,0	13,0	13,0	17,5	17,5	19,6	19,6
	SCOP	4,9	4,9	4,9	4,9	4,4	4,4	4,4	4,4	4,2	4,2	4,2	4,2	4,2	4,2	4,3	4,3
	η <sub>sh</sub> %	191,8	193,0	191,8	193,0	172,9	173,0	172,9	173,0	166,7	165,0	166,7	165,0	166,4	165,0	169,5	169,0
Heating PL Condition A	PhA kW	8,8	8,8	8,8	8,8	11,0	11,0	11,0	11,0	11,5	11,5	11,5	11,5	15,4	15,4	17,3	17,3
	COPA	3,5	3,5	3,5	3,5	2,8	2,8	2,8	2,8	2,6	2,6	2,6	2,6	2,7	2,7	2,6	2,6
Heating PL Condition B	PhB kW	5,3	5,3	5,3	5,3	6,7	6,7	6,7	6,7	7,0	7,0	7,0	7,0	9,4	9,4	10,5	10,5
	COPB	4,1	4,1	4,1	4,1	3,7	3,7	3,7	3,7	3,6	3,6	3,6	3,6	3,8	3,8	3,9	3,9
Heating PL Condition C	PhC kW	3,4	3,4	3,4	3,4	4,3	4,3	4,3	4,3	4,5	4,5	4,5	4,5	6,0	6,0	6,7	6,7
	COPC	7,7	7,7	7,7	7,7	7,5	7,5	7,5	7,5	7,4	7,4	7,4	7,4	6,6	6,6	6,8	6,8
Heating PL Condition D	PhD kW	4,0	4,0	4,0	4,0	4,0	4,0	4,0	4,0	4,0	4,0	4,0	4,0	6,4	6,4	6,6	6,6
	COPD	9,8	9,8	9,8	9,8	9,8	9,8	9,8	9,8	9,8	9,8	9,8	9,8	8,1	8,1	8,9	8,9
T bivalent	Tbiv °C	-10	-10	-10	-10	-9	-9	-9	-9	-7	-7	-7	-7	-7	-7	-7	-7
	PhTbiv kW	10,0	10,0	10,0	10,0	12,0	12,0	12,0	12,0	11,5	11,5	11,5	11,5	15,4	15,4	17,3	17,3
	COPTbiv	2,9	2,9	2,9	2,9	2,6	2,6	2,6	2,6	2,6	2,6	2,6	2,6	2,7	2,7	2,6	2,6
PsbC	W	14,0	14,0	14,0	14,0	14,0	14,0	14,0	14,0	14,0	14,0	14,0	14,0	18,0	18,0	18,0	18,0
PoffC	W	14,0	14,0	14,0	14,0	14,0	14,0	14,0	14,0	14,0	14,0	14,0	14,0	18,0	18,0	18,0	18,0
Ptoc	W	34,0	34,0	34,0	34,0	34,0	34,0	34,0	34,0	34,0	34,0	34,0	34,0	48,0	48,0	48,0	48,0
PckC	W	34,0	34,0	34,0	34,0	34,0	34,0	34,0	34,0	34,0	34,0	34,0	34,0	48,0	48,0	48,0	48,0
Psbh	W	38,0	38,0	38,0	38,0	38,0	38,0	38,0	38,0	38,0	38,0	38,0	38,0	48,0	48,0	48,0	48,0
Poffh	W	38,0	38,0	38,0	38,0	38,0	38,0	38,0	38,0	38,0	38,0	38,0	38,0	48,0	48,0	48,0	48,0
PtoH	W	38,0	38,0	38,0	38,0	38,0	38,0	38,0	38,0	38,0	38,0	38,0	38,0	48,0	48,0	48,0	48,0
Pckh	W	38,0	38,0	38,0	38,0	38,0	38,0	38,0	38,0	38,0	38,0	38,0	38,0	48,0	48,0	48,0	48,0
Sound power level / in heating	dB(A)	69 / 72	—	69 / 72	—	71 / 75	—	71 / 75	—	73 / 75	—	73 / 75	—	79 / 83	—	83 / 84	—

## Eurovent VRF certified technical data: 2-Pipe ECOi EX ME2 Series 8 to 20 HP - R410A

HP	8 HP		10 HP		12 HP		14 HP		16 HP		18 HP		20 HP		
Outdoor unit	U-8ME2E8		U-10ME2E8		U-12ME2E8		U-14ME2E8		U-16ME2E8		U-18ME2E8		U-20ME2E8		
Indoor units combination	4x	4x	4x	4x	6x	6x	2x	2x	6x	6x	6x	6x	8x	8x	
S-***MU2: S-***MU2E5C	S-56MU2	S-56MF2	S-73MU2	S-73MF2	S-56MU2	S-56MF2	S-60MU2	S-60MF2	S-73MU2	S-73MF2	S-60MU2	S-60MF2	S-73MU2	S-73MF2	
S-***MF2: S-***MF2E5A	2x	2x	2x	2x	4x	4x	2x	2x	2x	2x	2x	2x	2x	2x	
	S-73MU2	S-73MF2	S-73MU2	S-73MF2			S-73MU2	S-73MF2			S-73MU2	S-73MF2			
Cooling	Pc out <sup>1)</sup> kW	19,7	19,7	24,6	24,6	33,5	33,5	40,0	40,0	45,0	45,0	50,0	50,0	56,0	56,0
	Pec out <sup>2)</sup> kW	5,8	5,8	8,8	8,8	11,6	11,6	13,3	13,3	18,8	18,8	17,9	17,9	23,3	23,3
	EERout	3,4	3,4	2,8	2,8	2,9	2,9	3,0	3,0	2,4	2,4	2,8	2,8	2,4	2,4
Seasonal Cooling	SEER	7,4	7,4	7,0	7,0	6,7	6,7	7,2	7,2	6,4	6,4	7,6	7,6	7,0	7,0
	η <sub>sc</sub> %	294,3	293,0	275,4	277,0	266,6	265,0	286,0	285,0	254,3	253,0	299,2	301,0	278,2	277,0
Cooling PL Condition B	PcB kW	14,5	14,5	18,1	18,1	24,6	24,6	29,4	29,4	33,1	33,1	36,8	36,8	41,2	41,2
	EERB	5,7	5,7	4,8	4,8	4,6	4,6	4,9	4,9	4,2	4,2	5,0	5,0	4,6	4,6
Cooling PL Condition C	PcC kW	9,3	9,3	11,6	11,6	15,8	15,8	18,9	18,9	21,3	21,3	23,6	23,6	26,5	26,5
	EERC	11,8	11,8	9,6	9,6	8,1	8,1	9,4	9,4	8,2	8,2	9,8	9,8	9,0	9,0
Cooling PL Condition D	PcD kW	8,2	8,2	9,3	9,3	8,2	8,2	8,4	8,4	9,4	9,4	10,5	10,5	11,7	11,7
	EERD	13,7	13,7	18,9	18,9	18,4	18,4	22,6	22,6	22,1	22,1	25,2	25,2	24,6	24,6
Seasonal Heating	Pdesign kW	17,5	17,5	22,0	22,0	26,2	26,2	31,5	31,5	35,0	35,0	39,2	39,2	44,1	44,1
	SCOP	4,8	4,8	4,3	4,3	4,7	4,7	4,3	4,3	4,1	4,1	4,3	4,3	4,1	4,1
	η <sub>sh</sub> %	188,4	189,0	167,6	169,0	185,8	185,0	168,2	169,0	159,0	161,0	168,7	169,0	160,4	161,0
Heating PL Condition A	PhA kW	15,4	15,4	19,4	19,4	23,1	23,1	27,8	27,8	30,9	30,9	34,6	34,6	39,0	39,0
	COPA	2,8	2,8	2,6	2,6	2,8	2,8	2,5	2,5	2,3	2,3	2,6	2,6	2,4	2,4
Heating PL Condition B	PhB kW	9,4	9,4	11,8	11,8	14,1	14,1	16,9	16,9	18,8	18,8	21,1	21,1	23,7	23,7
	COPB	4,5	4,5	3,6	3,6	4,2	4,2	3,7	3,7	3,6	3,6	3,7	3,7	3,5	3,5
Heating PL Condition C	PhC kW	6,0	6,0	7,6	7,6	9,0	9,0	10,9	10,9	12,1	12,1	13,5	13,5	15,2	15,2
	COPC	7,2	7,2	7,7	7,7	7,7	7,7	7,4	7,4	6,6	6,6	7,1	7,1	6,9	6,9
Heating PL Condition D	PhD kW	7,1	7,1	7,0	7,0	7,2	7,2	6,7	6,7	6,6	6,6	7,4	7,4	7,4	7,4
	COPD	8,9	8,9	9,6	9,6	9,3	9,3	10,2	10,2	10,0	10,0	10,3	10,3	10,3	10,3
T bivalent	Tbiv °C	-9	-9	-7	-7	-9	-9	-7	-7	-7	-7	-7	-7	-7	-7
	PhTbiv kW	16,8	16,8	19,4	19,4	25,1	25,1	27,8	27,8	30,9	30,9	34,6	34,6	39,0	39,0
	COPTbiv	2,6	2,6	2,6	2,6	2,6	2,6	2,5	2,5	2,3	2,3	2,6	2,6	2,4	2,4
PsbC	W	48,0	48,0	48,0	48,0	48,0	48,0	88,0	88,0	88,0	88,0	88,0	88,0	88,0	88,0
Psbh	W	48,0	48,0	48,0	48,0	48,0	48,0	88,0	88,0	88,0	88,0	88,0	88,0	88,0	88,0
PoffC	W	48,0	48,0	48,0	48,0	48,0	48,0	88,0	88,0	88,0	88,0	88,0	88,0	88,0	88,0
Poffh	W	48,0	48,0	48,											









## Eurovent VRF certified technical data: 3-Pipe ECOi EX MF3 Series 8 to 16 HP · R410A

HP		8 HP		10 HP		12 HP		14 HP		16 HP	
Outdoor unit		U-8MF3E8		U-10MF3E8		U-12MF3E8		U-14MF3E8		U-16MF3E8	
Indoor units combination		4x S-56MU2	4x S-56MF2	4x S-73MU2	4x S-73MF2	6x S-56MU2	6x S-56MF2E	2x S-60MU2, 4x S-73MU2	2x S-60MF2, 4x S-73MF2	6x S-73MU2	6x S-73MF2
S-**MU2: S-**MU2E5C											
S-**MF2: S-**MF2E5A											
Cooling	Pc out <sup>1)</sup> kW	22,4	22,4	28,0	28,0	33,5	33,5	40,0	40,0	45,0	45,0
	Pec out <sup>2)</sup> kW	7,2	7,2	10,8	10,8	12,9	12,9	15,4	15,4	19,6	19,6
	EERout	3,1	3,1	2,6	2,6	2,6	2,6	2,6	2,6	2,3	2,3
Seasonal Cooling	SEER	7,0	7,0	7,0	7,0	6,4	6,4	6,7	6,7	6,0	6,0
	η <sub>sc</sub> %	277,7	277,0	278,9	277,0	252,7	253,0	264,4	265,0	237,7	237,0
Cooling PL Condition B	PcB kW	16,5	16,5	20,6	20,6	24,6	24,6	29,4	29,4	33,1	33,1
	EERB	4,9	4,9	4,6	4,6	4,3	4,3	4,4	4,4	3,9	3,9
Cooling PL Condition C	PcC kW	10,6	10,6	13,2	13,2	15,8	15,8	18,9	18,9	21,3	21,3
	EERC	9,1	9,1	9,3	9,3	7,7	7,7	8,3	8,3	7,4	7,4
Cooling PL Condition D	PcD kW	7,2	7,2	8,5	8,5	7,1	7,1	8,5	8,5	9,4	9,4
	EERD	16,5	16,5	19,7	19,7	15,7	15,7	19,7	19,7	17,4	17,4
Seasonal Heating	Pdesign kW	17,5	17,5	22,0	22,0	26,2	26,2	31,5	31,5	35,0	35,0
	SCOP	4,8	4,8	4,2	4,2	4,3	4,3	4,1	4,1	3,8	3,8
	η <sub>sh</sub> %	190,9	189,0	166,8	165,0	167,8	169,0	162,1	161,0	149,3	149,0
Heating PL Condition A	PhA kW	15,4	15,4	19,4	19,4	23,1	23,1	27,8	27,8	30,9	30,9
	COPA	2,9	2,9	2,5	2,5	2,7	2,7	2,4	2,4	2,2	2,2
Heating PL Condition B	PhB kW	9,4	9,4	11,8	11,8	14,1	14,1	16,9	16,9	18,8	18,8
	COPB	4,6	4,6	3,7	3,7	3,7	3,7	3,6	3,6	3,3	3,3
Heating PL Condition C	PhC kW	6,0	6,0	7,6	7,6	9,0	9,0	10,9	10,9	12,1	12,1
	COPC	7,1	7,1	7,4	7,4	6,9	6,9	7,1	7,1	6,5	6,5
Heating PL Condition D	PhD kW	6,7	6,7	6,9	6,9	6,5	6,5	6,6	6,6	6,6	6,6
	COPD	8,7	8,7	9,4	9,4	9,0	9,0	9,6	9,6	9,6	9,6
T bivalent	Tbiv °C	-9	-9	-7	-7	-9	-9	-7	-7	-7	-7
	PhTbiv kW	16,8	16,8	19,4	19,4	25,1	25,1	27,8	27,8	30,9	30,9
	COPTbiv	2,6	2,6	2,5	2,5	2,3	2,3	2,4	2,4	2,2	2,2
Psbc	W	17,0	17,0	17,0	17,0	17,0	17,0	25,0	25,0	25,0	25,0
Poffc	W	17,0	17,0	17,0	17,0	17,0	17,0	25,0	25,0	25,0	25,0
Ptoc	W	17,0	17,0	17,0	17,0	17,0	17,0	25,0	25,0	25,0	25,0
Pckc	W	50,0	50,0	50,0	50,0	50,0	50,0	91,0	91,0	91,0	91,0
Psbh	W	50,0	50,0	50,0	50,0	50,0	50,0	91,0	91,0	91,0	91,0
Poffh	W	50,0	50,0	50,0	50,0	50,0	50,0	91,0	91,0	91,0	91,0
PtoH	W	50,0	50,0	50,0	50,0	50,0	50,0	91,0	91,0	91,0	91,0
Pckh	W	50,0	50,0	50,0	50,0	50,0	50,0	91,0	91,0	91,0	91,0
Sound power level / in heating	dB(A)	79 / 77	—	80 / 82	—	84 / 86	—	86 / 86	—	86 / 88	—













## Features explained

### Energy saving.

-  **REFRIGERANT R32.** Our heat pumps using R32 refrigerant feature a low Global Warming Potential (GWP) of 675.
-  **INVERTER PLUS SYSTEM.** Inverter Plus system classification highlights Panasonic's highest performing systems.
-  **PANASONIC R2 ROTARY COMPRESSOR.** Designed to withstand extreme conditions, it delivers high performance and efficiency.
-  **ALL INVERTER COMPRESSORS.** Multiple large-capacity all Inverter compressors (more than 14 HP). Two independently controlled Inverter compressors achieve high-efficiency. Redesigned components in the body provide performance improvement especially in the rated cooling condition and EER performance.

-  **HIGH COP.** High-efficiency models performs higher COP than standard units and standard combinations.
-  **ECONAVI.** Intelligent human activity sensor and sunlight sensor technologies that can detect and reduces the waste of energy by optimising air conditioner operation according to room conditions. With just one touch of a button, you can save energy.
-  **ErP 2018.** Compliant following COMMISSION REGULATION (EU) No2016/2281.

### High performance and indoor air quality.

-  **BLUEFIN.** Panasonic has extended the life of its condensers with an original anti-rust coating.
-  **DOWN TO -10 °C IN COOLING MODE.** The air conditioner works in cooling mode when the outdoor temperature of -10 °C.
-  **DOWN TO -25 °C IN HEATING MODE.** The air conditioner works in heat pump mode when the outdoor temperature is as low as -25 °C.
-  **COOLING WITH OUTDOOR TEMPERATURE UP TO 52 °C.** The ECOi EX system works in cooling mode with performance data at outdoor temperature up to 52 °C.
-  **AUTOMATIC RESTART.** Automatic restart function for power failure. Even when power failure occurs, preset programmed operation can be reactivated once power is resumed.
-  **R22 RENEWAL.** The Panasonic renewal system allows good quality existing R22 pipe work to be re-used whilst installing high-efficiency R410A systems.
-  **NANOEX™ X.** Technology with the benefits of hydroxyl radicals has the capacity to inhibit pollutants, viruses, and bacteria to clean and deodorise.
-  **SELF-DIAGNOSING FUNCTION.** By using electronic control valves past warnings are stored. This makes it easier to diagnose malfunctions, reducing service labour and therefore costs.
-  **AUTOMATIC FAN OPERATION.** Convenient microprocessor control automatically adjusts fan speed to High, Medium or Low, corresponding to room sensor and maintains comfortable air flow throughout the room.
-  **MILD DRY.** By intermittent control of compressor and indoor unit's fan, "Mild Dry" gives you comfort. It realizes efficient dehumidification according to room temperature.
-  **COMFORTABLE AUTO-FLAP CONTROL.** When the unit is first turned on, flap position is automatically adjusted in accordance with the cooling or heating operation.
-  **AIR SWEEP.** The air sweep function moves the flap up and down in the air outlet, directing air in a "sweeping" motion around the room and providing comfort in every corner.

## High performance and indoor air quality (cont.).



**BUILT-IN DRAIN PUMP.** Maximum head 50 cm (or 75 cm for U type) from the bottom of the unit.



**5 YEARS COMPRESSOR WARRANTY.** We guarantee the outdoor unit compressors in the entire range for five years.



**FILTER INCLUDED.** Hide-away with filter included.

## High connectivity.



**DOMESTIC INTEGRATION TO S-LINK - CZ-CAPRA1.** Can connect RAC range to S-Link. Full control is now possible.



**BMS CONNECTIVITY.** The communication port can be integrated into the indoor unit and provides easy connection to, and control of, your Panasonic air conditioner to your home or Building Management System.



**INTERNET CONTROL.** A next generation system providing user-friendly control of air conditioning or heat pump units from everywhere, using a simple Android™ or iOS smartphone or tablet via Wi-Fi.

## Panasonic ECOi is Eurovent certified\*.

The Eurovent certification verifies the performance ratings of heating and cooling systems following European standards. Those data provides products efficiency with full transparency for the benefit of customers and professionals.



\*Reference website: <https://www.eurovent-certification.com/en>.

