



# Control and connectivity

Panasonic has developed a wide range of control systems to offer the best options for commercial and residential needs, from the individual remote controllers, to the newest technology capable of controlling your building anywhere in the world. The simple to use cloud software can even be used from a portable device.

## ABOUT

Control and connectivity map for Panasonic business areas	→ 429
Commercial Smart Edge	→ 431
Commercial Smart Edge Packages	→ 434
Commercial Wi-Fi Adaptor	→ 435
CONEX. Devices and apps	→ 437
Remote controller with Econavi	→ 441
Intelligent controller	→ 443
Econavi sensor	→ 445
Controller for hotel application	→ 447
A united BMS interface with S-Link	→ 449
Control and connectivity	→ 451
Individual controllers wired	→ 453
Individual wireless controllers	→ 455
Centralised controllers	→ 456
PACi NX and VRF connectivity	→ 459
PACi NX and ECOi connectivity indoor units	→ 461

## PRODUCT SPECIFICATIONS

### Individual controllers wired

CONEX wired remote controller	→ 453
Design wired remote controller	→ 453
Room controller for hotel rooms	→ 453
Display control for hotel rooms	→ 454
Redundancy control options for 24/7/365 applications with PACi NX	→ 454
Redundancy control options for 24/7/365 applications with PACi NX or VRF	→ 454

### Individual wireless controllers

Infrared remote controller	→ 455
Remote sensor	→ 455

### Centralised controllers

System controller with schedule timer	→ 456
ON / OFF controller	→ 456
Intelligent controller (touch screen panel)	→ 457
Local adaptor for ON / OFF control	→ 458
Demand control for Mini ECOi (LZ2, LE2) outdoor units	→ 458
Mini Seri-Para I/O Unit 0 -10 V	→ 458
Communication adaptor for VRF connectivity	→ 458

### PACi NX and ECOi connectivity indoor units

T10 connector (CN061)	→ 461
Fan drive connector (CN032)	→ 462
Option connector (CN060) output external signals	→ 462
EXCT connector (CN073)	→ 462
Option harness	→ 462

# Control and connectivity map for Panasonic business areas

A wide range of control and connectivity solutions to suit a variety of applications. Integration capability, scalable solutions and smart connectivity offer a unique portfolio to meet every customer's needs.

## Integration with Home Automation or KNX.

Simple and flexible solution to integrate Panasonic heating and cooling systems into smart home energy solutions.

Luxury housing estates

Condominiums

Small retails



## CONEX.

Simple and intuitive control with smart apps availability <sup>1)</sup>. Each of the specialized apps, for owners or HVAC&R professionals, support daily operation. Allows connection of one, or a group of indoor units, to Panasonic Comfort Cloud App, which provides control, monitoring, scheduling and error alerts. Compatible with Voice Control <sup>2)</sup>.

REFER TO PAGE 437 FOR MORE DETAILS 

<sup>1)</sup> App connectivity available with CZ-RTC6WBL, CZ-RTC6BL, CZ-RTC6WBLW2 and CZ-RTC6BLW2.

<sup>2)</sup> Alexa, Google Home... Giving indication of compatible options.

<sup>3)</sup> Edge controller box (PAW-CSE\*\*) is required.

<sup>4)</sup> 2 DI on standard version and 4 DI/DO available on Modbus version.

<sup>5)</sup> 128 indoor units as standard, additional communication adaptor required for 256 units.

### Commercial Smart Edge.

Manage the entire Panasonic HVAC portfolio from a single platform – on-site or remotely, 24/7.



**P-Smart Edge** <sup>31</sup>.  
A powerful smart control platform designed for single-site installations, giving you seamless management of the complete Panasonic HVAC range.



**P-Smart Nexus** <sup>31</sup>.  
An online multi-site control solution that provides remote, centralised supervision of all your locations worldwide.



REFER TO PAGE 431 FOR MORE DETAILS

Hotels



### Controller for hotel application.

Intuitive controller allowing up to 4 digital inputs and outputs <sup>41</sup>. Perform the most common operations in hotel rooms, such as key cards and window contacts.

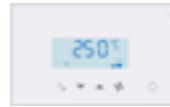

REFER TO PAGE 447 FOR MORE DETAILS



### Intelligent controller.

Centralized controller with large LCD touch screen display. Maximum 256 <sup>51</sup> indoor units connectable, ideal for larger buildings.

REFER TO PAGE 443 FOR MORE DETAILS

Supermarkets

Offices / Large buildings

### Integration with BACnet or Modbus.

Easy and reliable solution to integrate Panasonic heating and cooling systems into the building management systems in your business.

# Commercial Smart Edge

Step into the future of HVAC management with Commercial Smart Edge by Panasonic.

This solution brings flexible, scalable and intelligent control to commercial buildings of any size. Manage operations locally or remotely from any device, whether you oversee a single site or multiple locations.



The system improves comfort, enhances energy efficiency and supports proactive maintenance.

Designed also for professionals such as installers and service/maintenance companies, Commercial Smart Edge provides essential tools for simplified commissioning, remote configuration and streamlined service operations.

### Flexible and reliable solution for your business



Anytime



Anywhere

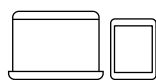

Multiplatform



Data ownership guaranteed

### Scalable solution for your business

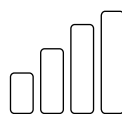

Small to large

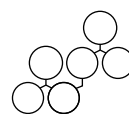

1 to multi-sites



Upgrade features <sup>1)</sup>

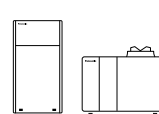

ECOi-W, ECOi, PACi NX, Aquarea, RAC <sup>2)</sup>

1) Customised to meet user demand / Continuous upgrades: new functions and product introductions / IT smart management. 2) RAC: Residential air to air heat pumps.

## Commercial Smart Edge consists of two complementary platforms



### One screen. Complete control for single sites.

P-Smart Edge centralises the management of your Panasonic HVAC system locally or remotely on a single platform, providing real-time visibility, intuitive control and improved energy performance for single-site installations.



### Smart Multi-Site Control Solution.

P-Smart Nexus enables 24/7 monitoring and management of HVAC units across multiple locations, improving energy efficiency, preventing breakdowns and reducing operational costs through scalable, centralised control.

**A powerful smart control platform designed for the seamless management of the complete Panasonic HVAC range.**

Edge controller box

**Manage the entire Panasonic HVAC portfolio from a single platform – on-site or remotely, 24/7.**



**COMPATIBLE WITH ENTIRE HVAC RANGE**

**SIMPLIFIED COMMISSIONING**

**OPTIMISED PLANT MANAGEMENT**

**ADVANCED ANALYTICS**

**Key functions and uniqueness**



- Optimised plant managements.**
- Complete overview of the building's HVAC system
  - Products organized by building zones or system groups for fast diagnostics and efficient system monitoring
  - 3 different user profiles: facility manager, installer and maintenance



- Weekly scheduled operations.**
- Customize daily or grouped schedules
  - Set operating modes and setpoints
  - Include special modes for energy savings
  - Define seasonal logic for summer/winter schedules



- Energy consumption monitoring.**
- Configure digital I/O signals to manage peak power consumption
  - Connect electricity meters for electrical energy calculations



- P-Smart Nexus: smart multi-site remote management.**
- Remote global supervision of all your sites in one place
  - 24/7 control of all the installations
  - Easy connection to Commercial Cascade Edge without special on-site network setup
  - 3-year subscription from the start-up included
  - Online visualization, no installation of any specific software is required

Note: User interface design may vary.

# Commercial Smart Edge – System overview example

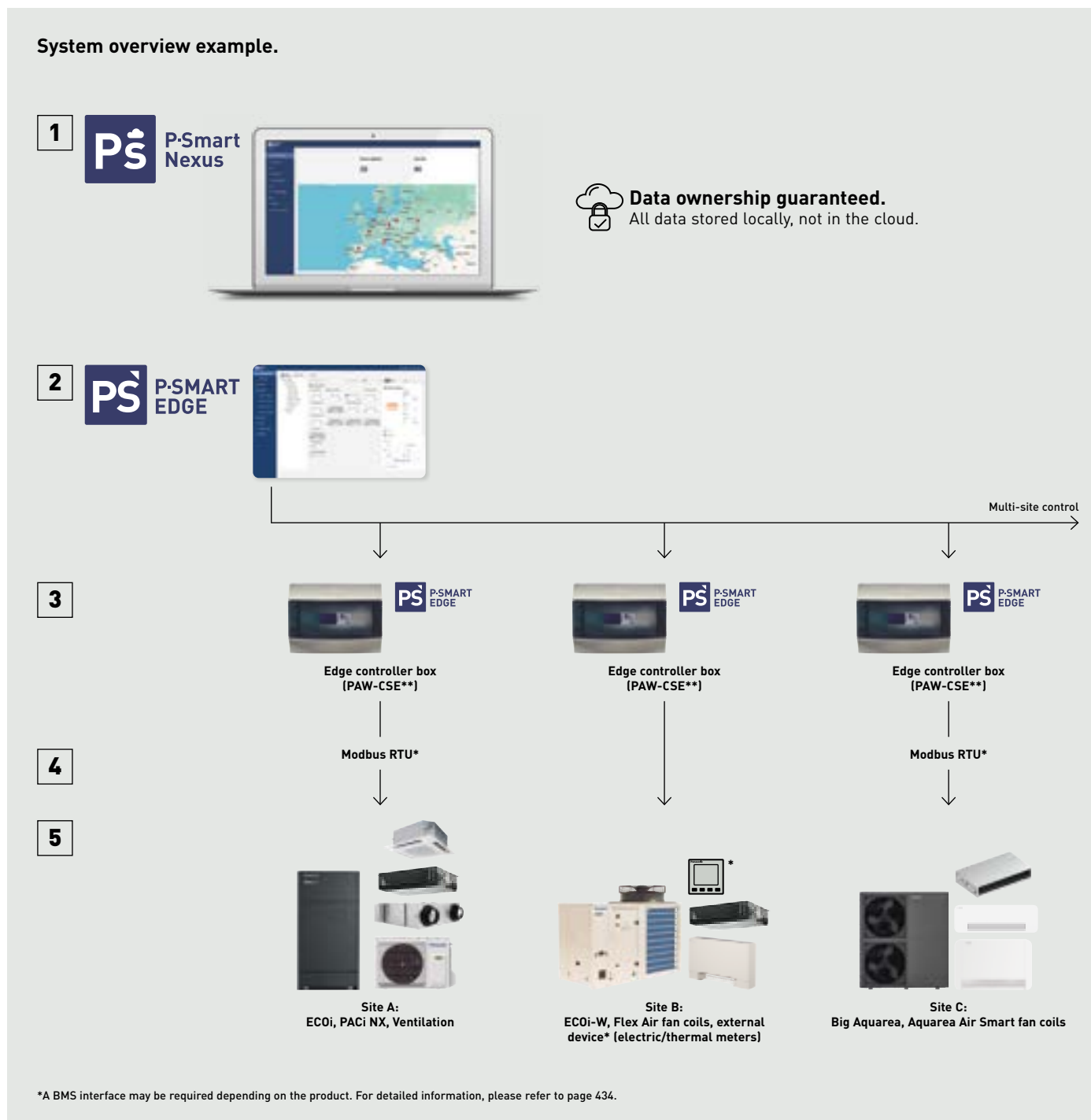

**1 P-Smart Nexus.**  
Smart multi-site control which allows a remote global supervision of all your sites. Control your different installations wherever you are, with easy on-site network setup.

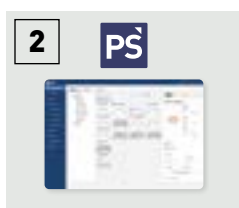

**2 P-Smart Edge.**  
Control and monitoring solution for HVAC projects – designed for single-site management, even remotely from outside your installation location.



**3 Edge controller box – (PAW-CSE-\*\*).**  
Choose the model based on the number of control points required.



**4 Modbus interface.**  
A BMS interface may be required depending on the product. For detailed information, please refer to page 434.

\*The image of the interface is an example.

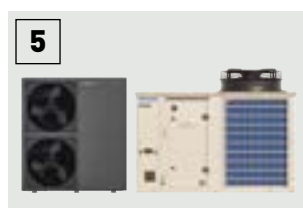

**5 Panasonic HVAC system.**  
Smartly manage the entire project, even when combining different Panasonic HVAC ranges. The Edge controller box is compatible with ECOi-W, ECOi EX, PACi NX, Aquarea, and RAC\* ranges.

\*RAC: Residential air to air heat pumps.

# Commercial Smart Edge – Packages

## Steps

**Step 1** | Verify the type and number of indoor and outdoor units

**Step 2** | Determine the required control points for the project

**Step 3** | Select the appropriate gateway based on your project specifications

## Basic package

Package size = Control points <sup>1)</sup>	Commercial Smart Edge	Model reference	Product description
<b>100</b>	Edge controller box	PAW-CSE-1B <sup>2)</sup>	Edge controller box for Commercial Smart Edge <sup>3)</sup> . Control points: 100
	Start up and configuration fee <sup>4)</sup>	SR-CSE-SETUP	Commercial Smart Edge start up and configuration
	P-Smart Nexus access fee	SR-CSE-1SUB	P-Smart Nexus access fee for <b>1 year</b> <sup>5)</sup>
<b>200</b>	Edge controller box	PAW-CSE-2B <sup>2)</sup>	Edge controller box for Commercial Smart Edge <sup>3)</sup> . Control points: 200
	Start up and configuration fee <sup>4)</sup>	SR-CSE-SETUP	Commercial Smart Edge start up and configuration
	P-Smart Nexus access fee	SR-CSE-2SUB	P-Smart Nexus access fee for <b>1 year</b> <sup>5)</sup>
<b>1000</b>	Edge controller box	PAW-CSE-10	Edge controller box for Commercial Smart Edge <sup>3)</sup> . Control points: 1000
	Start up and configuration fee <sup>4)</sup>	SR-CSE-SETUP	Commercial Smart Edge start up and configuration
	P-Smart Nexus access fee	SR-CSE-10SUB	P-Smart Nexus access fee for <b>1 year</b> <sup>5)</sup>
<b>2000</b>	Edge controller box	PAW-CSE-20	Edge controller box for Commercial Smart Edge <sup>3)</sup> . Control points: 2000
	Start up and configuration fee <sup>4)</sup>	SR-CSE-SETUP	Commercial Smart Edge start up and configuration
	P-Smart Nexus access fee	PAW-CSE-20SUB	P-Smart Nexus access fee for <b>1 year</b> <sup>5)</sup>

## Required BMS interface <sup>6)</sup>

Main system	Model reference	Product description
<b>PACi NX/ECOi indoor units</b>	PAW-RC2-MBS-1	DIN rail-mounted Modbus RTU interface for 1 indoor unit
	PAW-AC2-EDGE64	PACi NX and ECOi interface for Commercial Smart Edge, for 64 Indoor units
<b>Ventilation</b>	Not required <sup>7)</sup>	
<b>RAC indoor units</b>	PAW-AC-MBS-1	DIN rail-mounted Modbus gateway for 1 indoor unit. Powered via CN-CNT. For RAC models with CN-CNT connector
<b>ECOi-W outdoor units</b>	Not required <sup>7)</sup>	
<b>ECOi-Loop</b>	Not required <sup>7)</sup>	
<b>Aquarea outdoor units</b>	CZ-NSMB-C	Modbus RTU gateway, compatible with Aquarea H Series onwards
<b>Aquarea Air</b>	Not required <sup>7)</sup>	
<b>Flex Air</b>	Not required <sup>8)</sup>	
<b>ECOi-RT Rooftop</b>	Not required <sup>7)</sup>	
<b>Electricity meters</b>	PAW-CSE-4I40 <sup>9)</sup>	Inputs device to connect electrical meters and fire alarm input on PAW-CSE-1B and PAW-CSE-2B

1) Please refer to the technical manual for the required control points for each product range. 2) Doesn't include digital input. 3) 3 years access fee is included. 4) Not mandatory. Startup and configuration can be managed by the customer. 5) The first 3 years of access are included in the gateway cost. After the 3rd year, an access subscription is required for continued service. 6) Follows category commercial policy. 7) Modbus RTU is available without an additional interface. 8) Plogic or PAW-FC-\*\*\* controls are required. 9) Required only for PAW-CSE-1B, 2B. PAW-CSE-10, 20 include this function by default.

## Licence upgrade

Extend the number of control points required for your projects by purchasing a package extension.

Control points upgrade	Model reference
<b>100 --&gt; 200</b>	SR-CSE-1T2
<b>100 --&gt; 1000</b>	SR-CSE-1T10
<b>100 --&gt; 2000</b>	SR-CSE-1T20
<b>200 --&gt; 1000</b>	SR-CSE-2T10
<b>200 --&gt; 2000</b>	SR-CSE-2T20
<b>1000 --&gt; 2000</b>	SR-CSE-10T20

## Commercial Wi-Fi Adaptor

Panasonic CZ-CAPWFC2 interface adaptor, allows connection of one or a group of indoor units to Panasonic Comfort Cloud App, which provides control, monitoring, scheduling, and error alerts.



Comfort Cloud



### 1 From 1 to 200 units

User can control up to 10 different sites, with up to 20 units / groups per site. Additionally, one adaptor can be connected to 1 indoor or to a group of up to 8 indoors.

### 2 Voice control compatible

Registering the unit to Panasonic Comfort Cloud App makes it compatible with the most popular voice assistants.

### 3 Multi user

The Panasonic Comfort Cloud App allows multi-user access control, whilst allowing user restriction to specific units.

### 4 Easy scheduling

Complex weekly scheduling made simple. Not only for one unit, but across multiple sites, and from a smartphone.

### 5 Energy monitor

See the estimated power consumption and compare with other periods, to see how energy consumption can be further reduced. Check list of units that provides consumption\*.

\*Function available depending on the model.

### 6 Error codes

Error code notification through the App, provides early notification and allows for faster repair.

**Control PACi NX and ECOi indoor units with your smartphone whenever and wherever you are, by using Panasonic Comfort Cloud App and Commercial Wi-Fi Adaptor.**



**Advanced smartphone control.**

This scalable solution is ideal for one system, one site or multiple locations. Coupling the adapter with the already feature rich systems, makes it an ideal solution for residential and commercial applications.

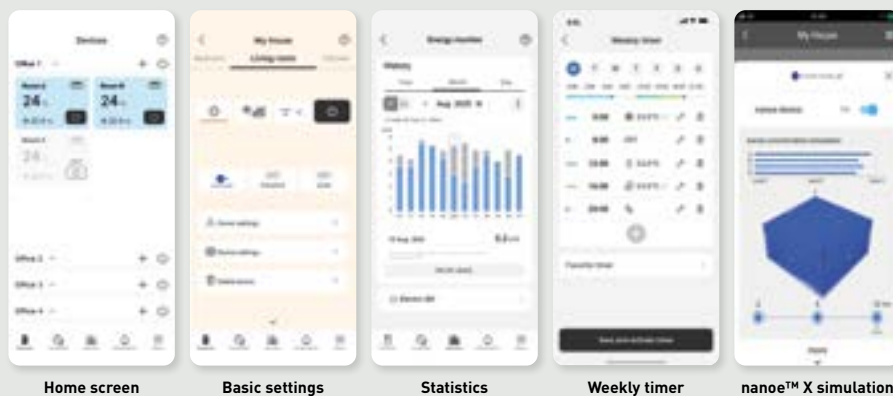

**Connection diagram**

Commercial Wi-Fi Adaptor wiring length is 1,9 m and connects to indoor unit via T10 connector and R1/R2 terminal connectors.

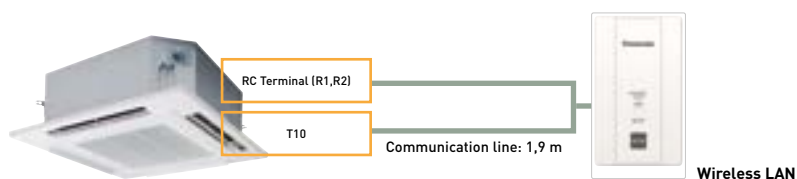

Input Voltage	12 V DC (supplied from T10 connector)
Power Consumption	Maximum 2,4 W
Size (HxWxD)	120 x 70 x 25 mm
Weight	190 g (including communications lines)
Interface	1 x Wireless LAN
Wireless LAN Standard	IEEE 802,11 b/g/n

Frequency Range	2,4 GHz band
Operating range	0 ~ 55 °C, 20 ~ 80 RH%
Connectable indoor unit	1 unit
Length of communication line	1,9 m (included)

**Panasonic Comfort Cloud App**

**Download free app.**

Other hardware requirements: Wi-Fi internet connection (not included) and Smartphone or tablet with internet access. The Panasonic Cloud Server is fully managed and operated by Panasonic. \*The app screen is for illustration purposes only. The actual screen may differ.



# CONEX. Devices and apps

CONEX provides comfort and control for varying user needs.



Comfort Cloud



**Intuitive operation with simple and modern design panel.**

REFER TO PAGE 453 FOR MORE DETAILS



Sophisticated design with white or black flat panel and compact body. From residential to commercial, the wired remote controller series perfectly matches with all kinds of modern building. It enables user to recognize each function with a simple glance.

**Accessible, flexible, and scalable with different controllers and apps. Perfectly meeting requirements of modern controls for end user, installer, and service.**

**1 Intuitive control with stylish design**

- Simple operation at a glance
- Clean face with full flat and LCD display
- Compact body, only 86x86 mm

**2 Control comfort with your smartphone**

- Flexible control options with IoT integration
- Panasonic H&C Control App for daily remote control operation
- Panasonic Comfort Cloud App for remote operation 24/7/365

**3 Easy maintenance with service support app**

- Quick and easy app set-up for system setting
- Panasonic H&C Diagnosis App enables the user to obtain detailed system operation data

\*The use of apps depends on the remote controller model.

**CONEX with IoT integration**

The wired remote controller CONEX is fully integrated with IoT solutions developed by Panasonic.

Detailed operation, maintenance setting and service operation are all possible with smartphone or tablet.

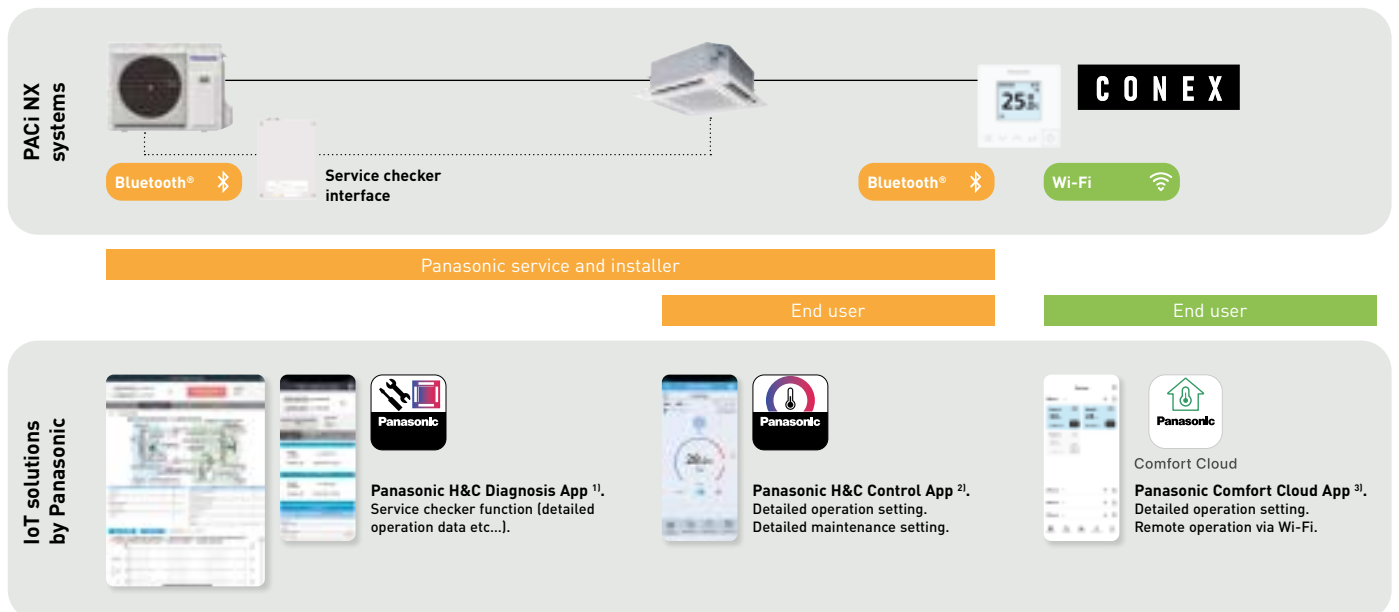

1) A service checker interface is required when this app is used from outdoor location. Wired remote controller (CZ-RTC6WBL, CZ-RTC6BL, CZ-RTC6WBLW2 or CZ-RTC6BLW2) is required when this app is used from indoor location. Compatible with PZ3 and PZH3 outdoor units. 2) CZ-RTC6WBL, CZ-RTC6BL, CZ-RTC6WBLW2 or CZ-RTC6BLW2 required. 3) CZ-RTC6WBLW2 or CZ-RTC6BLW2 required.

**Service checker interface.**

The service checker interface provides easy access to service parameters and service checker data via Bluetooth®.

- A Service checker interface for PACi NX Series\*
- Bluetooth® connection
- Panasonic H&C Diagnosis App

\*Available as a spare part, compatible with PACi NX Series.

Input voltage	220-240 V ~ 50-60 Hz (supplied from outdoor unit)
Power consumption	Maximum 2,4 W (including outdoor units)
Size (H x W x D)	175 x 125 x 50 mm
Weight	—
Interface	Bluetooth® 4.2 or later
Frequency range	2,4 GHz band*
Operating range - Temperature / Humidity	0 ~ 40 °C / 20 ~ 80% (no condensation)

\*Frequency band in which the radio equipment operates; 2402 - 2480 MHz.

\*Maximum radio-frequency power transmitted in the frequency bands in which the radio equipment operates; +0 dBm.



# CONEX. Devices and apps

Flexible control options with IoT integration. 3 different apps for individual usage.

## Panasonic H&C Diagnosis App for service and installer

Tool for diagnosis and troubleshooting.



### Available functions:

- AC control
  - System view
  - Refrigerant circuit view
- Real-time data
  - Indoor unit
  - Outdoor unit
- Refrigerant cycle diagram and graph
- Data recording
- History data
- Error code tables



Main

Operation data

History data

Equipment control

## Panasonic H&C Control App for end user, service and installer

Detailed operation setting. Detailed maintenance setting.



### Available functions:

- ON / OFF, mode, temperature, air flow volume, air flow direction
- Weekly timer
- All energy saving functions
- Alarm display and history
- Filter sign
- Test run
- Sensor value monitor
- Simple setting mode
- Detailed setting mode
- Key lock
- Ventilation fan control
- Display contrast adjustment
- Rotation, redundancy
- Quiet mode
- nanoe™ X
- Power consumption
- Unit naming



Home screen

Basic settings

Statistics

Weekly timer

Advanced settings

## Panasonic Comfort Cloud App for end user

Remote operation via Wi-Fi.



Comfort Cloud

### Available functions:

- ON / OFF
- Mode
- Temperature
- Air flow volume
- Air flow direction
- Weekly timer
- Temperature setting range limitation
- Energy monitoring
- Alarm display
- nanoe™ X

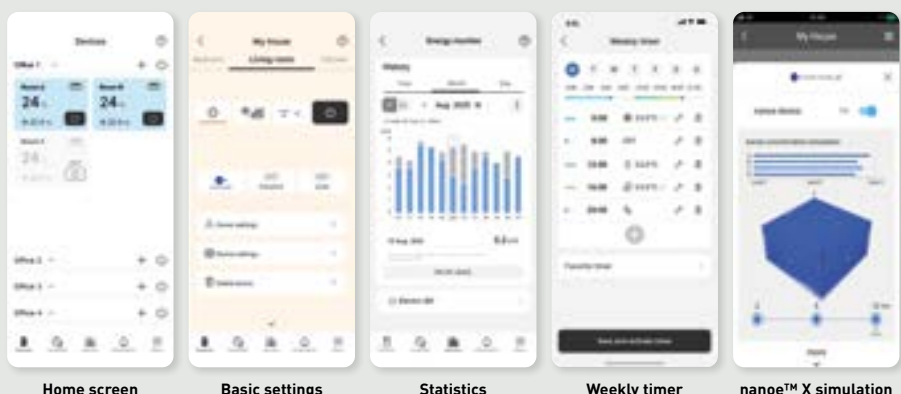

Home screen

Basic settings

Statistics

Weekly timer

nanoe™ X simulation

## Connectivity matrix.



White model	CZ-RTC6W	CZ-RTC6WBL	CZ-RTC6WBLW2
Black model	CZ-RTC6	CZ-RTC6BL	CZ-RTC6BLW2
Wired connection compatible with	PACi NX and ECOi	PACi NX and ECOi	PACi NX and ECOi <sup>1)</sup>
Wireless functions	No wireless capability	Bluetooth®	Bluetooth® + Wi-Fi
<b>App compatibility</b>			
Panasonic Comfort Cloud App	—	—	✓
Panasonic H&C Control App	—	✓ PACi NX and ECOi	✓ PACi NX only
Panasonic H&C Diagnosis App <sup>2)</sup>	—	✓ PACi NX only <sup>3)</sup>	✓ PACi NX only <sup>3)</sup>
Outdoor unit settings (remote controller connected to indoor unit)	✓ PACi NX only <sup>3)</sup>	✓ PACi NX only <sup>3)</sup>	✓ PACi NX only <sup>3)</sup>

1) Available with ECOi indoor unit types MY3, MF3, MM2, and MK3. 2) Compatible with U-71/100/125/140PZH3E5/8 and U-100/125/140PZ3E5/8. 3) When connected to PACi NX indoor and outdoor unit combination.

## Function comparison

This shows the functions provided:		Remote controller functionalities	Panasonic H&C Control App	Panasonic Comfort Cloud App			
a) by the remote controllers		CONEX		CONEX			
b) by the apps		CONEX		CONEX			
		CZ-RTC5B	CZ-RTC6W / CZ-RTC6	CZ-RTC6WBL(W) / CZ-RTC6BL(W) + app	CZ-CAPWFC2 + app	CZ-RTC6WBLW2 / CZ-RTC6BLW2 + app	
<b>Basic operation</b>	ON / OFF, mode, temperature, air flow volume, air flow direction	✓	✓	✓	✓	✓	
<b>Timer functions</b>	Time display	✓	—	✓	✓	✓	
	Easy ON / OFF timer	✓	—	✓	—	—	
	Weekly program timer	✓	—	✓	✓	✓	
<b>Energy saving</b>	Outing function	✓	✓	✓	—	—	
	Temperature auto return	✓	—	✓	—	—	
	Temperature setting range limitation	✓	—	✓	✓	✓	
	OFF reminder	✓	—	✓	—	—	
	Energy saving mode	✓	—	✓	—	—	
	Schedule demand control	✓	—	✓	—	—	
	Energy monitoring	✓	—	✓	✓	✓	
	Econavi	✓	✓	✓	✓	✓	
	<b>Maintenance</b>	System failure information (alarm history)	✓	✓	✓	—	—
		Alarm display	✓	✓	✓	✓	✓
Service contact registration		✓	—	✓	—	—	
Filter sign		✓	✓	✓	—	—	
Test run		✓	✓	✓	—	—	
Sensor value monitor		✓	✓	✓	—	—	
Simple setting mode		✓	✓	✓	—	—	
<b>Others</b>	Detailed setting mode	✓	✓	✓	—	—	
	Key lock	✓	✓	✓	—	—	
	Ventilation fan control	✓	—	✓	—	—	
	Display contrast adjustment	✓	✓	✓	—	—	
	Rotation	✓	—	✓	—	—	
	Quiet operation mode	✓	—	✓	—	—	
	nanoe™ X	✓	✓	✓	✓	✓	

## Remote controller with Econavi

Easy to use, attractive, clear design, with demand control functions and energy consumption display! This useful feature makes this remote controller unique!



### 1 Design

The CZ-RTC5B wired remote controller is ideal for integration into the most demanding interior architectures.

The touch panel features a very sleek and easy to use display, which with its compact display is only 120 x 120 x 16 mm.

### 2 Key functions

- Easy setup of the timer and settings of the indoor unit
- Energy consumption display (for all PACi NX)
- Limitation of the energy consumption (Demand control) by timer.

### 3 Display of information

The information is mainly based on pictograms to ensure easy understanding. The minimal amount of text is available in 6 languages (English / German / French / Spanish / Italian / Polish).

The screen is back lit to enable reading even during the night.

### 4 Easy access to the menus

With the pictograms, the navigation, the selection and the settings are simple and easy to follow.

## Basic function (operation display and indication).

REFER TO PAGE 453 FOR MORE DETAILS 

All functions are easily available on the remote controller.

- ON / OFF timer
- Weekly timer
- Quiet operation
- Remote controller sensor
- Operation prohibit
- Filter sign
- Energy saving
- Centralized control indication
- Mode change prohibit
- Automatic temperature return
- Temperature range limitation
- OFF remind
- Schedule demand control
- Ventilation
- Out Function

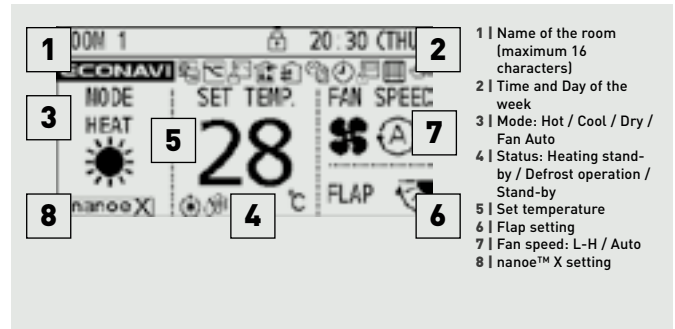

- 1 | Name of the room (maximum 16 characters)
- 2 | Time and Day of the week
- 3 | Mode: Hot / Cool / Dry / Fan Auto
- 4 | Status: Heating stand-by / Defrost operation / Stand-by
- 5 | Set temperature
- 6 | Flap setting
- 7 | Fan speed: L-H / Auto
- 8 | nanoe™ X setting

### Easy operation and quick access to all menus

- 1 | Set temperature will be selected, when any arrow button is touched
- 2 | Select the item (Mode or Fan speed) by left/right ◀▶ key
- 3 | Change the setting by up/down ▲▼ key

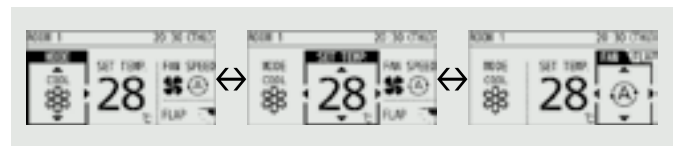

### Example of easy access to the functions: air direction setting

- 1 | Select "Air direction" and press "Enter" key
- 2 | Select the unit number by up/down ▲▼ key
- 3 | Select the flap position by up/down ▲▼ key
- 4 | Press "Return" key to go back the Menu display

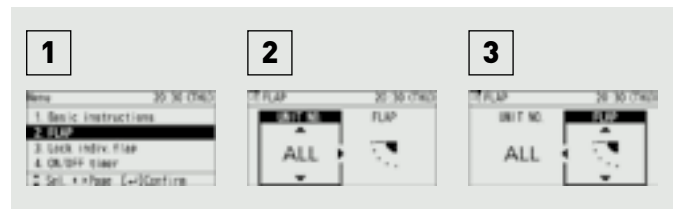

### Backup control by using CZ-RTC5B

Group wiring of 2 systems of PACi NX can do auto individual control: Rotation operation, backup operation and support operation.

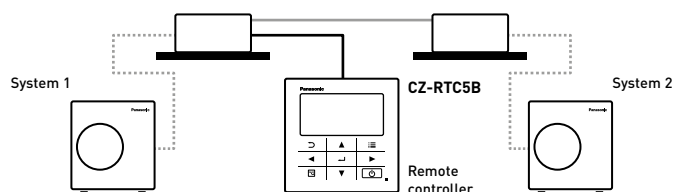

### Functions available on the CZ-RTC5B

Control item	Controllability	Indoor units	
		PACi NX	VRF
Basic operation	Operation, Mode, Temperature setting, Air flow volume, Air flow direction	✓	✓
	Time display	✓	✓
Timer function	Easy ON / OFF timer	✓	✓
	Weekly program timer	✓	✓
Energy saving	Outing function	✓	✓
	Temperature auto return	✓	✓
	Temperature setting range limitation	✓	✓
	OFF remind	✓	✓
	Energy saving mode	✓	✓
Others	Schedule demand control	✓	✓
	Energy monitoring - R32	✓	—

Control item	Controllability	Indoor units	
		PACi NX	VRF
Maintenance	System failure information	✓	✓
	Service contact registration	✓	✓
	Filter sign (rest time display) and reset	✓	✓
	Auto-address, Test run	✓	✓
	Sensor value monitor	✓	✓
Others	Simple / Detail setting mode	✓	✓
	Key lock	✓	✓
	Ventilation fan control	✓	✓
	Display contrast adjustment	✓	✓
	Remote controller sensor	✓	✓
Others	Quiet operation mode	✓	—
	Prohibit setting control from central controller	✓	✓

\*All specifications subject to change without notice.

## Intelligent controller

This controller is the smart solution for your advanced requirement in buildings.



**Intuitive operation.**

REFER TO PAGE 457 FOR MORE DETAILS 

The screens used for operations all follow a common pattern, with the screens being easy to read and easy to use.

- Enlarged screen (10,4 inch) with colour LCD
- Smartphone-like gestures (flick, swipe, touch)

Large screen display. Enlarged by 60%.



Easy swipe or flick operation.



**Swipe.**  
This is an operation where the finger is slid in a direction (up or down) on the touch panel. This is used to scroll slowly.

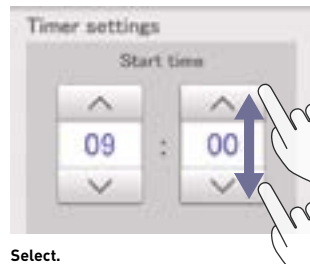

**Select.**  
This is an up and down movement of the finger touching the screen, used to pick settings in elements such as spin boxes.

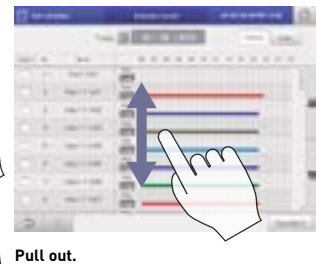

**Pull out.**  
This is an operation where the finger on the touch panel is flicked in a direction (up or down). This is used to scroll quickly.

**Enhanced functions for energy saving as standards**

- Set temperature auto return settings, Auto shut OFF, set temperature range limit settings
- Demand control function

Screen of set temperature auto return setting.



Auto shut OFF.



Screen of outdoor demand control.



- Outdoor demand input and timer settings possible
- Indoor can be set at  $\pm 1$  °C/ $\pm 2$  °C or thermostat OFF
- Indoor units controlled in sequence at 10-minute intervals

**Energy visualization**

- Energy saving plans are supported with graph display function
- Displays electricity and gas usage distribution

Screen of graph display.



Useful parameters are shown for your better energy saving. Ex.) Bar graph:

Indoor unit: Total operating time, thermostat ON operation time (Min.)  
Amount used (electricity, gas)  
Electricity or gas charges

Outdoor unit: Outdoor unit operation cycles (# cycles)  
Engine time in operation (Hrs.)  
Cumulative Inverter power output  
Cumulative PV power output

Pulse value selection per different data intervals 1 hour/1 day/ 1 month compared with last year.

**Main function**

Gesture function (flick, swipe, touch)	✓
Graph display (trends, comparisons)	✓
Web functions (maximum 64 users)	✓
Recipient setting for warning email	✓ (Maximum 8)
Automatic return to setting temperature	✓
Limitation of setting temperature range	✓
Left-on prevention	✓
Quiet operation of outdoor unit	✓
Occupant sensor linkage	✓
Demand function	✓
Charge calculation	✓
Log display	✓ Warning 10000 items. Status change 50000 items
Linked control (event definition 50 events, input: 32, output: 32)	✓
Under maintenance (under inspection registration)	✓

## Econavi sensor

The Econavi sensor detects presence in the room, and quietly adapts the PACi NX or VRF air conditioning system in order to improve comfort and energy savings.



- Detects human activity and adjusts temperature by 2 degrees (up or down) to optimise comfort and efficiency
- If there is no activity detected for a set time period, the Econavi will stop the unit or move to a temperature previously set
- The Econavi device is installed independently of the indoor unit, and is located in the area best suited for detection

**Applications**

**Saving energy for offices:** If the air conditioning is left on after the last employee leaves the office, Econavi will automatically react, reducing or stopping the system.  
**Increased comfort in hotel rooms:** When presence is detected in the room, the temperature is automatically adjusted to achieve best comfort.

**Key points**

- Compatible with cassette, wall-mounted, hide-away and Ceiling units
- Improves efficiency
- Better comfort
- Can be installed in the best location within the room for detection purposes

**Sensor location image.**

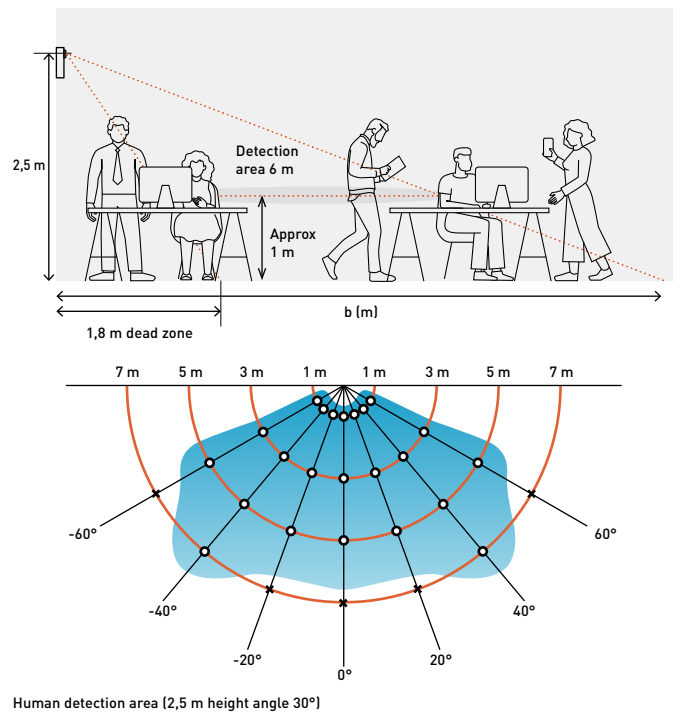

Providing outstanding energy saving performance, Panasonic's Inverter system can be connected to Econavi to detect when energy is being wasted. Econavi senses the presence or absence of people and the level of activity in each area of an office. When unnecessary heating or cooling is detected, indoor units are individually controlled to match office conditions for energy saving operation.

**Detection of the level of activity enables precise power saving.**

Presence or absence of people at their desks and the level of activity in the office are detected in real time. Set temperature is automatically adjusted to optimise the lower power consumption.

**Remote Econavi sensor allows optimum energy operation.**

Pillars, walls, cabinets and other fittings obstruct the sensor, reducing the area of detection and lowering the energy saving effect. Taking into consideration blind spots, Panasonic enables the optimum layout for sensors in any office.



**Econavi sensor: CZ-CENSC1**

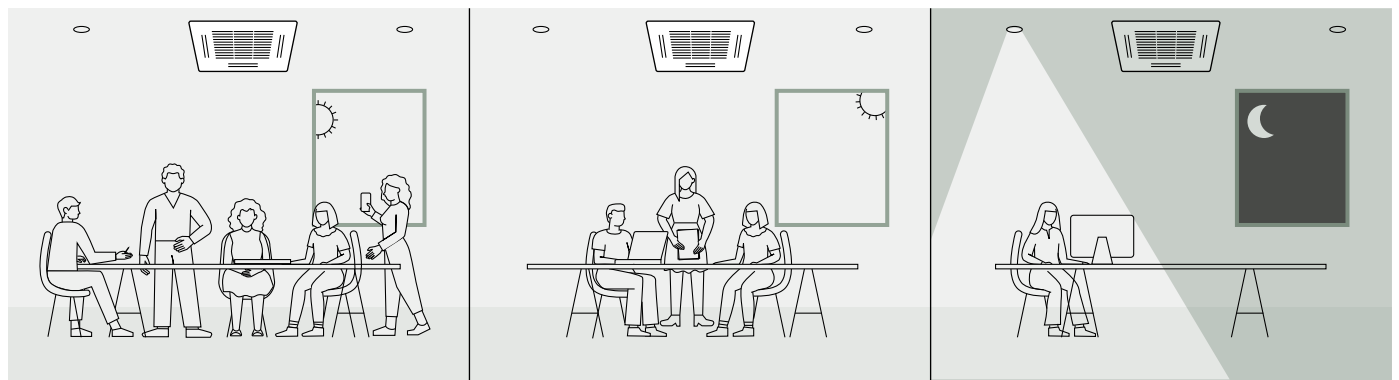

**In the morning.**  
Thorough cooling when there is a high level of activity.

**In the afternoon.**  
Reduced cooling when there are fewer people.

**At night.**  
Automatic Thermo OFF depending on conditions at the end of the day.

## Controller for hotel application

Innovative line up of room controllers specially designed for hotel applications. With a modern cosmetic that match room interiors and simple operation for hotel guests.



**3** Room card switch (field supply).

**Controller to integrate all room hotel needs in one device.**  
Card switch. Heating and cooling control. Light control. Window control. Possible to connect to Modbus.



Lighting control.



Wall silent motion sensor PAW-WMS-AC (-DC).



Indoor unit. Variable static pressure hide-away.



Door or window contact PAW-DWC.



Ceiling silent motion sensor PAW-CMS-AC (-DC).

- Easy to install
- Cost effective installation as all electrical cables are centralized on the remote: The lighting, card contact, motion detector, window contact and the air conditioning are controlled
- Architect inspired attractive design with 2 colors: black or white
- Stand alone and Modbus
- Bespoke finish by special order

REFER TO PAGE 453 FOR MORE DETAILS 

**NFC fast set up.**

With the touch display control and touch room controller setting are quicker than ever. Just touching smartphone with NFC capability the settings will be saved. This function is also possible even when the control is not wired. Giving flexibility to save the setting even before installation.

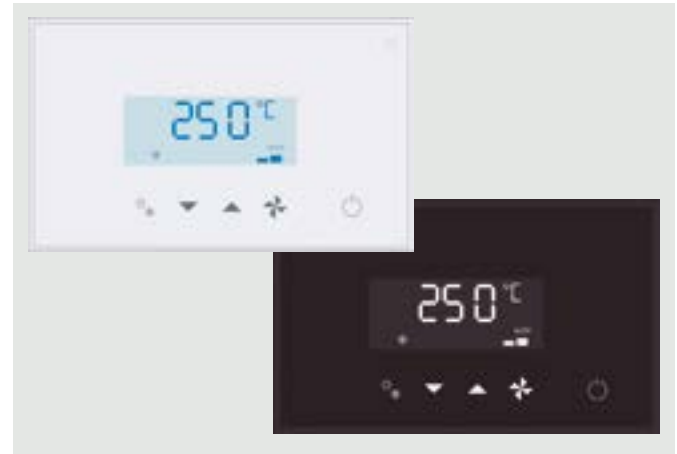

**Energy saving functions included on the device.**

Turns OFF air conditioning and lighting when room is unoccupied. Disables air conditioning when window is open. Configurable maximum/minimum setpoint temperature.

**Easy remote controller.**

The hotel guest will have access to limited functions to control the air conditioning: ON / OFF, Temperature and Fan speed.

**Easy set up.**

Stand alone model with easy configuration menu to access all parameters. A pre-define scenario can be uploaded on the remote controller connected to a computer to make installation on site Plug & Play (only on the Modbus models).

Type	Model	Colors	Digital inputs	Digital output	BMS	Inst. set up	T. sensor
Touch display controller	PAW-RE2D4-WH	White	2			NFC	Built-in
	PAW-RE2D4-BK	Black	2			NFC	Built-in
Touch room controller	PAW-RE2C4-MOD-WH	White	4	4	Modbus	NFC	Built-in
	PAW-RE2C4-MOD-BK	Black	4	4	Modbus	NFC	Built-in

**Room controller: 4 digital inputs and 4 digital output**

Room controller offers flexibility and easy installation thanks to 4 preconfigured options. This is available in Modbus type. Modbus references: PAW-RE2C4-MOD-WH, PAW-RE2C4-MOD-BK.

Wiring configuration example for option 2 in Modbus type.

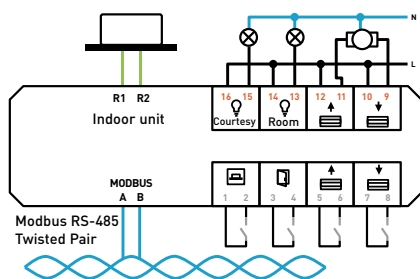

Configurations	4 options available I/O configurations: Inputs				Available I/O Configurations: Outputs			
	Digital 1-2	Digital 3-4	Digital 5-6	Analog 7-8	Relay 15-16	Relay 13-14	Relay 11-12	Relay 9-10
Option 1	Card	Window	Lighting	Temperature	Courtesy	Lighting	Not used	Valve actuator
Option 2	Card	Window	Blinds up	Blinds down	Courtesy	Lighting	Blinds up	Blinds down
Option 3	Motion sensor	Window	Door contact	Temperature	Courtesy	Lighting	Not used	Valve actuator
Option 4	Lighting	Window	Blinds up	Blinds down	Not used	Lighting	Blinds up	Blinds down

**Display: 2 digital inputs**

Display control allows to handle 2 inputs to perform most common operation in room hotels. References: PAW-RE2D4-WH, PAW-RE2D4-BK.

Wiring example for display controller.

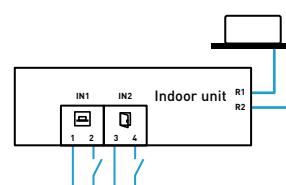

Configurations	3 options available: Inputs	
	IN1 (1-2)	IN2 (3-4)
Option 1	Card	Window
Option 2	Motion sensor	Window
Option 3	Motion sensor	Door contact

Hotel room controller	
PAW-RE2C4-MOD-WH	Modbus RS-485 touch room controller with I/O, white
PAW-RE2C4-MOD-BK	Modbus RS-485 touch room controller with I/O, black
PAW-RE2D4-WH	Touch display control with 2 digital inputs, white
PAW-RE2D4-BK	Touch display control with 2 digital inputs, black

Accessories sensors	
PAW-WMS-DC	Wall silent motion sensor 24 V
PAW-WMS-AC	Wall silent motion sensor 240 V AC
PAW-CMS-DC	Ceiling silent motion sensor 24 V
PAW-CMS-AC	Ceiling silent motion sensor 240 V AC
PAW-24DC	Power supply 24 V
PAW-DWC	Door or window contact

## A united BMS interface with S-Link

Introducing a unified BMS interface, compatible with Modbus, BACnet, and KNX protocols. PAW-AC2-BMS-16, 64, 128.

BMS interface with Panasonic communication bus helps you to get significant savings. Easy to use and reliable interfaces for a straightforward integration.



Modbus®

Home  
automation

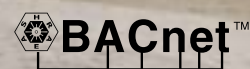

# 1 Direct connection to S-Link communication bus

The interface can provide faster, cheaper, easier solution in your projects!

- No need for additional gateway (CZ-CFUNC2)
- Significant 50% cost saving for BMS interface\*
- Avoid mistakes and reduce configuration time

\*In the case of PAW-AC2-BMS-16 by Panasonic calculation.  
 \*\*One BMS protocol is available per one interface.

System example with the unified BMS interface.

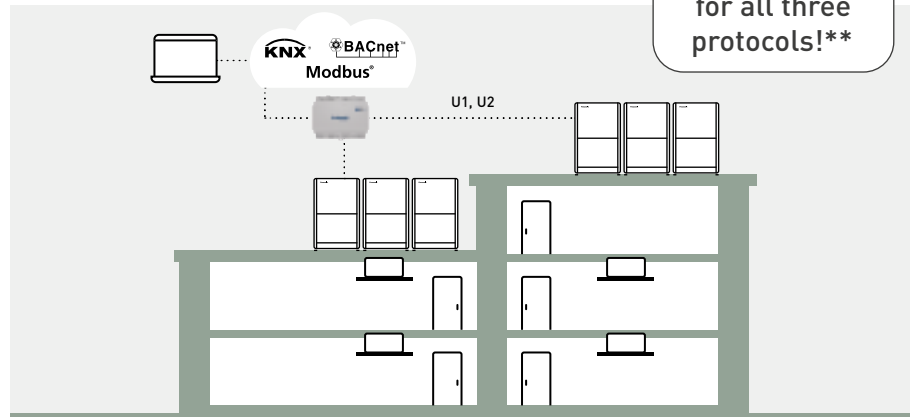

U1U2 link is connected directly to IntesisBox. Support from 16 to 128 per each interface.

# 2 Easy configuration

- A single device supporting all Modbus, BACnet, and KNX protocols
- Dedicated configuration support tool (MAPs for Panasonic)
- Firmware updates with improvements and features
- Scan: Automatic identification of the units present in the VRF system



Screen examples of MAPs for Panasonic.

# 3 Upgraded specifications

- Electricity consumption calculation using three inputs from pulse meters or Modbus meters
- BACnet: Version 14 and BTL Certified
- Modbus and BACnet 128 units now supports IP and RTU/MSTP
- **NEW!** MQTT Support available for third-party cloud monitoring, analytics, and remote control

## Home automation compatibility for Smart Home systems for PAW-AC2-BMS-\*\*

Drivers available for:

**AMX, Control4, eedomus, Elan, Fibaro, iRidium, Eedom, RTI, Savant, Creston, Kuju and Vera**



<b>PAW-AC2-BMS-16</b>	A unified interface supporting Modbus, BACnet, and KNX protocols for up to 16 indoor units
<b>PAW-AC2-BMS-64</b>	A unified interface supporting Modbus, BACnet, and KNX protocols for up to 64 indoor units
<b>PAW-AC2-BMS-128</b>	A unified interface supporting Modbus, BACnet, and KNX protocols for up to 128 indoor units

Version	Connectable indoor units	Connectable outdoor units	Number of S-Link communication bus port
<b>16</b>	1-16	1-16	1
<b>64</b>	1-64	1-30	1
<b>128</b>	128 (1-64 / S-Link communication bus port)	60 (1-30 / S-Link communication bus port)	2

# Control and connectivity

A wide variety of control options to meet the requirements of different applications.

## Centralized control systems

### Intelligent controller.



**Intelligent controller.**  
Up to 256 indoor units touch screen with web server.  
CZ-256ESMC3

### Commercial Smart Edge.



**Edge controller box.**  
Up to 2000 control points.  
PAW-CSE-1B / PAW-CSE-2B / PAW-CSE-10 / PAW-CSE-20

### Connection with general equipment.



**ON / OFF control for external devices such as ERV.**  
Controls 3 units.  
CZ-CAPC4



**Demand control for Mini ECOi (LZ2, LE2).**  
Up to 4 outdoor units.  
CZ-CAPDC3



**Mini Seri-Para I/O Unit 0 - 10 V.**  
Controls 1 indoor unit or a group of 8 indoor units.  
CZ-CAPBC2



**Communication Adaptor.**  
Up to 128 groups. Controls 128 units.  
CZ-CFUNC2

## Domestic integration to S-Link

### CZ-CAPRA1

Can connect RAC range to S-Link. Full control is now possible.

#### Integrates any unit in big system control.

- YKEA server room integration <sup>1)</sup>
- Small offices with domestic indoors
- Tender for refurbishment (old system Domestic and VRF in one installation)
- Centralized Control Systems: 64 indoor units
- Intelligent controller / Web Server: 256 indoor units
- Panasonic Commercial Smart Edge

- Basic operation items: ON / OFF, Mode select, Temperature setting, Fan speed, Flap setting, Remote control prohibit
- External input: ON / OFF control signal, Abnormal stop signal
- External output for Relay <sup>2)</sup>: Operation status (ON / OFF), Alarm status output

1) When duty rotation using the remote controller is set up, CZ-CAPRA1 cannot be connected.  
2) Because current CN-CNT connector can not provide the power for external output relay, additional 12 V DC power supply for external relay is necessary.

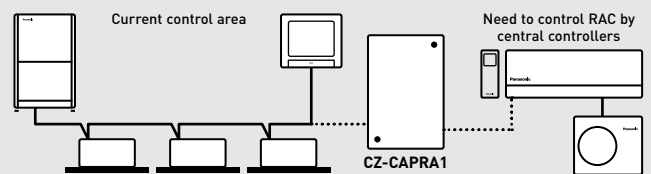

Current system for PACI NX / VRF. Central controller can connect to S-Link line to control units directly.

RAC units cannot connect directly to S-Link to be managed by Central Controllers.

It's necessary to have interface between S-Link and RAC protocol to cover basic operating items.









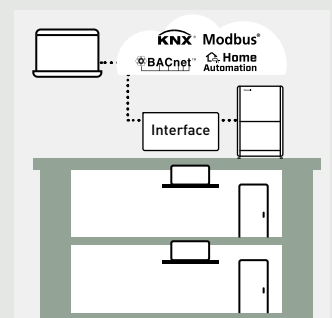

## Easy connection to KNX, Modbus, BACnet and Proprietary Home Automation Systems

Easy and reliable solution to integrate your Panasonic heating and cooling systems into any BMS or BEMS.

Fully bi-directional communications with all necessary parameters.

For more information, contact Panasonic.



			Econavi control	Built-in thermostat	Indoor units which can be controlled	Use limitations	Function ON / OFF	Mode setting	Fan speed setting	Temperature setting	Air flow direction	Permit/Prohibit switching	Weekly program	BMS protocol
<b>Individual controllers</b>														
CONEX Wired remote controller		CZ-RTC6W CZ-RTC6 Non-wireless	✓	✓	1 group, 8 units	· Up to 2 controllers can be connected per group	✓	✓	✓	✓	✓	—	—	—
		CZ-RTC6WBL CZ-RTC6BL With Bluetooth®	✓	✓	1 group, 8 units	· Up to 1 controller can be connected per group	✓	✓	✓	✓	✓	—	✓	—
		CZ-RTC6WBLW2 <sup>1)</sup> CZ-RTC6BLW2 <sup>1)</sup> With Wi-Fi and Bluetooth®	✓	✓	1 group, 8 units	· Up to 1 controller can be connected per group	✓	✓	✓	✓	✓	—	✓	—
Design wired remote controller		CZ-RTC5B	✓	✓	1 group, 8 units	· Up to 2 controllers can be connected per group	✓	✓	✓	✓	✓	—	✓	—
Touch room controller for hotel with Dry Contact and Modbus		PAW-RE2C4-MOD-WH PAW-RE2C4-MOD-BK  WH: White, BK: Black. Bespoke finish available on request.	—	✓	1 indoor unit	—	✓	✓	✓	✓	—	✓	—	Modbus + 4 digital I/O signals
Touch display control for hotel with Dry Contacts		PAW-RE2D4-WH PAW-RE2D4-BK  WH: White, BK: Black. Bespoke finish available on request.	—	✓	1 indoor unit	—	✓	✓	✓	✓	—	✓	—	Stand Alone + 2 digital inputs
Infrared remote controller		CZ-RWS3 + CZ-RWRU3 CZ-RWS3 + CZ-RWRY3W CZ-RWS3 CZ-RWS3 + CZ-RWRL3 CZ-RWS3 + CZ-RWRD3 CZ-RWS3 + CZ-RWRT3 CZ-RWS3 + CZ-RWRC3	✓	—	1 group, 8 units	· Up to 2 controllers can be connected per group	✓	✓	✓	✓	✓ <sup>2)</sup>	—	—	—
<b>Centralized controllers</b>														
System controller with weekly timer		CZ-64ESMC3	✓	—	64 groups, maximum 64 units	· Up to 10 controllers, can be connected to one system · Main unit/sub unit (1 main unit + 1 sub unit) connection is possible · Use without remote controller is possible	✓	✓	✓	✓	✓ <sup>2)</sup>	✓	✓	—
Central ON / OFF controller		CZ-ANC3	—	—	16 groups, maximum 64 units	· Up to 8 controllers (4 main units + 4 sub units) can be connected to one system · Use without remote controller is impossible	✓	—	—	—	—	✓	—	—
Intelligent controller (touch screen/ web server)		CZ-256ESMC3	✓	—	Main unit: 128. Up to 256 units can be expanded	· Communication adaptor CZ-CFUNC2 is necessary for connection with more than 128 units	✓	✓	✓	✓	✓ <sup>2)</sup>	✓	✓	—

1) Available for indoor unit types MY3, MF3, MM2, and MK3. 2) Setting is not possible when a remote controller unit is present (use the remote controller for setting). \*All specifications subject to change without notice.

# Individual controllers wired

## CONEX wired remote controller

### CZ-RTC6W // CZ-RTC6 // CZ-RTC6WBL // CZ-RTC6BL // CZ-RTC6WBLW2 // CZ-RTC6BLW2

- 3 line-up: - CZ-RTC6W // CZ-RTC6: Non-wireless
  - CZ-RTC6WBL // CZ-RTC6BL: Bluetooth®
  - CZ-RTC6WBLW2 <sup>1)</sup> // CZ-RTC6BLW2 <sup>1)</sup>: Wi-Fi and Bluetooth®
- Colours: 6W: White. 6: Black
- Intuitive control with stylish design profile
- Clean face with full flat and LCD display
- Dimension (HxWxD): 86 x 86 x 25 mm

#### Panasonic H&C Control App <sup>2)</sup>.

Daily remote control operation via Bluetooth® // · Quick and easy App set-up for system setting.

#### Panasonic H&C Diagnosis App <sup>3)</sup>.

Easy access to service parameters and service checker data via Bluetooth®.

#### Panasonic Comfort Cloud App.

Especially designed for end users // Remote operation via Wi-Fi.

**Basic operation:** Mode setting: Heat-Cool-Dry-Fan-Auto // Temperature setting // Fan speed: 5 levels // Air flow direction // nanoe™ X and Econavi setting // Weekly program <sup>4)</sup>.

1) Available for PACi NX Series and ECOi indoor units types MY3, MF3, MM2 and MK3.

2) CZ-RTC6WBL, CZ-RTC6BL, CZ-RTC6WBLW2 or CZ-RTC6BLW2 required.

3) A service checker interface is required. Compatible with PACi NX Series.

4) Can be set from Panasonic H&C Control App.

CONEX



Comfort Cloud

nanoe™ X

ECONAVI

## Design wired remote controller

### CZ-RTC5B

- Power consumption monitor (only for PACi NX)
- Flat face design and touch sensor switch for stylish design and operating usability
- Functions such as for energy saving and monitoring and for service use are available on the full dot LCD (3,5" display)
- Improved illumination
- White LED backlit
- Blink when alarm occurs

\*Panasonic App is required on your smartphone.

**Basic operation:** Operation // Mode // Temperature setting // Air flow volume // Air flow direction.

**Timer function:** Outing function // Weekly program timer // Easy ON / OFF timer // Time display.

**Energy saving:** Outing function // Temperature setting range limitation // Temperature auto return // OFF remind // Schedule demand control // Energy saving mode // Energy monitoring.

**Others:** Key lock // Ventilation fan control // Display contrast adjustment // Remote controller sensor // Quiet operation mode // Prohibit setting control from central controller // Rotation / backup control.

\*Rotation and backup control with CZ-RTC5B is available for all PACi NX systems.



nanoe™ X

ECONAVI

## Room controller for hotel rooms

### PAW-RE2C4-MOD-WH // PAW-RE2C4-MOD-BK

- Easy to install
- Cost effective installation as all electrical cables are centralised on this remote
- Architect inspired attractive design
- Direct connection to the Indoor unit with all primary functions of indoor unit available
- 2 options available: Stand alone and Modbus communication
- Colours: WH: White. BK: Black
- Room controller: 4 digital inputs and 4 digital outputs

#### From this remote controller.

The lighting, card contact, motion detector, window contact and the air conditioning are controlled.

#### Energy saving functions included on the device.

- Turns OFF air conditioning and lighting when room is unoccupied
- Disables air conditioning when window is open
- Maximum/minimum setpoint temperature configurable

#### Fast and simple set up.

Set up is simple and easy for room controllers. It is extremely easy and quick with touch models, which can be set up by using smartphone with NFC technology, even when control is not yet installed / powered.

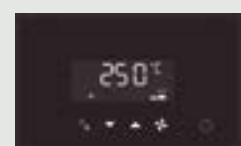

## Display control for hotel rooms

### PAW-RE2D4-WH // PAW-RE2D4-BK

- Easy to install
- Cost effective installation as all electrical cables are centralised on this remote
- Architect inspired attractive design
- Direct connection to the Indoor unit with all primary functions of indoor unit available
- Stand alone communication
- Colours: WH: White. BK: Black
- Basic hotel function: 2 digital inputs

#### From this remote controller.

The card contact, motion detector, window contact and the air conditioning are controlled.

#### Energy saving functions included on the device.

- Disables air conditioning when window is open
- Maximum/minimum setpoint temperature configurable

#### Fast and simple set up.

Set up with smartphone with NFC technology, even when control is not yet installed/powerd.



## Redundancy control options for 24/7/365 applications with PACi NX

### CZ-RTC5B / CZ-RTC6W / CZ-RTC6 / CZ-RTC6WBL / CZ-RTC6BL / CZ-RTC6WBLW2 / CZ-RTC6BLW2

- Full redundancy functionality
- Quick and easy installation using PACi NX group control
- Up to 2 PACi NX systems connectable to 1 remote controller
- Delta T setting for support operation selectable from 4 to 10 K
- Connectable to Panasonic centralised control systems
- Optional interfaces for connection to external BMS (Modbus, BACnet, KNX)

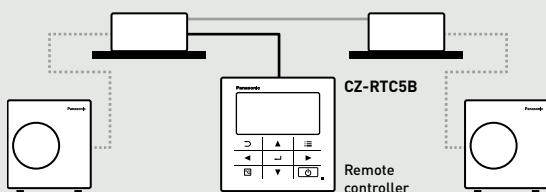

## Redundancy control options for 24/7/365 applications with PACi NX or VRF

### PAW-PACR4

- Redundancy control up to 4 indoor unit groups
- Actual unit operation / alarm status can be displayed
- Common digital alarm / operation status output
- For each support operation level, individual temperature thresholds can be set (cascade control)
- Room temperature display (by device's own temperature sensor)
- Modbus connection (up to 4 PAW-RC2-MBS-1)
- Available external inputs (ON / OFF, heating/cooling change\*, fire prevention contact)

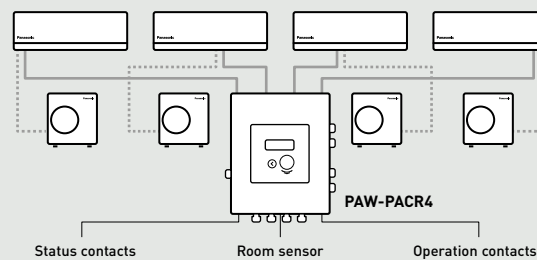

\*External input heating/cooling change only for the interface control logic, not for the indoor unit mode change.

# Individual wireless controllers

## Infrared remote controller

**CZ-RWS3 + CZ-RWRU3 // CZ-RWS3 + CZ-RWRY3W // CZ-RWS3 // CZ-RWS3 + CZ-RWRL3 // CZ-RWS3 + CZ-RWRD3 // CZ-RWS3 + CZ-RWRT3 // CZ-RWS3 + CZ-RWRC3**

- Easy installation for the 4 Way Cassette type by simply replacing the corner part
- 24 hour timer function
- Remote controller by main remote controller and sub controller is possible (maximum 2 remote controllers (main remote controller and sub controller) can be installed for one indoor unit)
- When CZ-RWS3 is used, infrared control becomes possible for all indoor units (1: when a separate receiver is set up in a different room, control from that room also becomes possible. 2: automatic operation by means of the emergency operation button is possible even when the remote controller has been lost or the batteries have been exhausted)
- Operation of separate energy recovery ventilators (when commercial ventilation fans or heat-exchange ventilation fans have been installed, they can be operated with this remote controller (interlocked operation with the indoor unit or independent ventilation ON / OFF)



Infrared remote controller and receiver for 4 way 90x90 cassette. CZ-RWS3 + CZ-RWRU3



Infrared remote controller and receiver for 4 way 60x60 cassette with white panel (RAL9003). CZ-RWS3 + CZ-RWRY3W



Infrared remote controller for wall-mounted and floor console. CZ-RWS3



Infrared remote controller and receiver for 2 way cassette. CZ-RWS3 + CZ-RWRL3



Infrared remote controller and receiver for 1 way cassette. CZ-RWS3 + CZ-RWRD3



Infrared remote controller and receiver for ceiling. CZ-RWS3 + CZ-RWRT3



Infrared remote controller and receiver for all indoor units. CZ-RWS3 + CZ-RWRC3



## Remote sensor

### CZ-CSRC3

- This remote sensor can be connected to any PACi NX or VRF unit. Use it to detect the room temperature when no remote controller sensor or body sensor is used (connection to a system without a remote controller is possible)
- For joint use with a remote controller switch, use the remote controller switch as main remote controller
- Batch group control for up to 8 indoor units
- Appearance design based on simplified remote controller chassis
- Dimension (H x W x D): 120 x 70 x 17 mm
- Weight: 70 g
- Temperature/Humidity range: 0 °C to 40 °C / 20% to 80% (no condensation) (indoor use only)
- Power supply: 16 V DC (supplied from indoor unit)
- Maximum number of connectable indoor units: Up to 8 units



Control contents	Part name, model No.	Quantity
Standard control	High spec wired remote controller: CZ-RTC5B CONEX wired remote controller: CZ-RTC6W // CZ-RTC6 // CZ-RTC6WBL // CZ-RTC6BL // CZ-RTC6WBLW2 // CZ-RTC6BLW2 Infrared remote controller: CZ-RWS3 + CZ-RWRU3 // CZ-RWS3 + CZ-RWRY3W // CZ-RWS3 // CZ-RWS3 + CZ-RWRL3 // CZ-RWS3 + CZ-RWRD3 // CZ-RWS3 + CZ-RWRT3 // CZ-RWS3 + CZ-RWRC3	1 unit each
(1) Group control	High spec wired remote controller: CZ-RTC5B CONEX wired remote controller: CZ-RTC6W // CZ-RTC6 // CZ-RTC6WBL // CZ-RTC6BL // CZ-RTC6WBLW2 // CZ-RTC6BLW2 Infrared remote controller: CZ-RWS3 + CZ-RWRU3 // CZ-RWS3 + CZ-RWRY3W // CZ-RWS3 // CZ-RWS3 + CZ-RWRL3 // CZ-RWS3 + CZ-RWRD3 // CZ-RWS3 + CZ-RWRT3 // CZ-RWS3 + CZ-RWRC3	8 units
(2) Main/sub. remote controller	Main or sub.: High spec wired remote controller: CZ-RTC5B CONEX wired remote controller: CZ-RTC6W // CZ-RTC6 // CZ-RTC6WBL // CZ-RTC6BL // CZ-RTC6WBLW2 // CZ-RTC6BLW2 Infrared remote controller: CZ-RWS3 + CZ-RWRU3 // CZ-RWS3 + CZ-RWRY3W // CZ-RWS3 // CZ-RWS3 + CZ-RWRL3 // CZ-RWS3 + CZ-RWRD3 // CZ-RWS3 + CZ-RWRT3 // CZ-RWS3 + CZ-RWRC3	As required

# Centralised controllers

## System controller with schedule timer

### CZ-64ESMC3

Operation with various functions from central station.

**Panasonic unveils state-of-the-art digital controller.**

Panasonic's innovative and easy to use interface that offers full functionality with an integrated schedule timer and system controller, making managing heating and cooling systems easier than ever before. The CZ-64ESMC3 includes Panasonic's popular schedule timer, which gives users full flexibility over when they want their property heated or cooled. Users can adjust the system for holidays, pausing operations for long periods of time so that energy isn't wasted heating or cooling an empty home or office. The controller also allows six operations per day to be programmed.

### Mix of current 2 controllers: System controller + schedule timer.

System controller will be designed by taking priority on these 2 operations with following technical key points:

- Same operation feeling as wired remote controller by touch-key panel
- High visibility and usability by full-dot LCD
- Based on high wired remote controller
- Maximum 64 group of indoor units, individual control for 64 units
- 4 zone control; 1 zone = maximum 16 groups
- Several energy saving function (based on CZ-RTC5B)
- 6 timer program per day for 1 week (7 days) operation (total 6 x 7= 42 programs)
- Basic setting items (Temperature, Mode, Fan speed, Flap position) can be set by same manner as CZ-RTC5B

### Function list:

Central control functions:

- Central control / individual setting
  - Start-stop prohibition for remote controller
  - Start-stop / Mode change / Temperature setting prohibition for remote controller
  - Mode change / Temperature setting prohibition for remote controller
  - Mode change prohibition for remote controller
  - Select items for prohibition
- Filter information
  - Filter sign
  - Filter sign reset
- Ventilation setting

Timer functions and external I/O:

- Weekly timer
  - Timer setting enable / disable
  - Copy of timer setting
- Maintenance
  - External signal (Start / Stop) (Demand control)
  - Centralized control master-slave setting
  - Alarm history
- Initial setting
  - Clock

Energy saving, maintenance and operating functions:

- Energy saving control
  - Econavi ON / OFF
- Filter information
  - Filter sign and hour counter display
- Maintenance
  - Service contact
- Initial setting
  - Clock display setting
  - Name Setting
  - Operation lock setting
  - Operation sound setting
  - LCD contrast setting
  - LCD backlight setting
  - Select displayed language (EN/FR/IT/ES/DE)
  - Administrator password
- Setting information list



**ECONAVI**

Sample display image / Operation status display

Operation Status ALL



Operation Status ZONE



Operation Status GROUP



## ON / OFF controller

### CZ-ANC3

Only ON / OFF operation from central station.

- 16 groups of indoor units can be controlled
- Collective control and individual group (unit) control can also be performed
- Up to 8 ON / OFF controller (4 main, 4 sub) can be installed in one link system
- The operation status can be determined immediately
- Dimension (HxWxD): 121 x 122 x 14 + 52 mm (embedding dimension)

Power supply: 220 to 240 V AC.

I/O part: Remote input (effective voltage: within 24 V DC): All ON / OFF.

Remote output (allowable voltage: within 30 V DC): ON, Alarm.

Note: As operation mode and temperature settings are not possible with the ON / OFF controller, it must be used together with a remote controller, a system controller etc.



# Centralised controllers

## Intelligent controller (touch screen panel)

### CZ-256ESMC3

#### Simplified load distribution ratio (LDR) for each tenant.

- Dimension (HxWxD): 240 x 280 x 20 (+60) mm
- Power supply: Single phase 100-240 V ~ 50/60 Hz
- Maximum number of connectable indoor units: 256 units (maximum per link: 64 units)
- Maximum number of connectable outdoor units: 120 units (maximum per link: 30 units)
- Central control device: Up to 10 units
- Enlarged display screen: 10,4 inch touch-panel colour LCD. Pursuing visibility, ease of use. Retrieve data from USB memory: Place the USB port inside the panel (USB memory available in stores)
- Communication adaptor: CZ-CFUNC2\*

\*CZ-CFUNC2 is required to connect more than 128 indoor units.

#### Functions:

- Graph display (trends, comparisons)
- Econavi ON / OFF
- Outdoor unit quiet operation ON / OFF
- Energy saving functions: Set temperature auto return settings, Auto shut OFF, Set temperature range limit settings, Energy saving for PAC current value, etc.
- Event control (such as equipment linkage)
- Performs closing at end of any period

#### Operation and status.

You can check to operational status (ON / OFF, operating mode, alarms, etc.) of all indoor units and outdoor units in real time. You can also select indoor units to change their settings.

#### Operation scheduling.

You can register daily operation schedules (ON / OFF time, operating modes, set temperatures, etc.) for individual indoor units or groups of indoor units. Operations can be schedule for up to 2 years in advance.

#### Load distribution calculation for each tenant.

- Air-conditioner load distribution ratio is calculated for each unit (tenant) with used energy consumption data (m<sup>3</sup>, kWh)
- Calculated data is stored as a CSV type file
- Data from the last 365 days is stored

#### Web application. Web access and control from remote station.

- Accessing from remote PC
- You can monitor/operate system by using web browser



#### Remote controller.

The LAN terminal on this unit enables you connect it to a network. Connecting to Internet will enable you to operate the unit and check the status using a PC from a remote location\*.

\*Remote access rights and additional IT infrastructure / programming may be required.

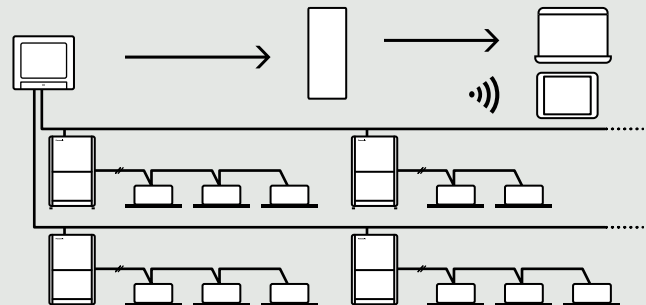

#### Backup tool to save your commissioning time.

Various data such as distribution, setting, log history etc. can be saved by CSV file. Setting data of CSV file is available to edit and import to the controller again. You can save time for commissioning and change setting flexibly and easily by your PC.

- Customize data
  - Data recovery
- Data can be imported again by general USB.

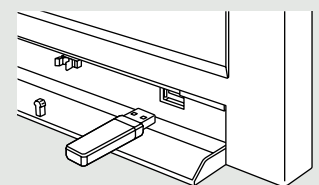

#### System configuration example.

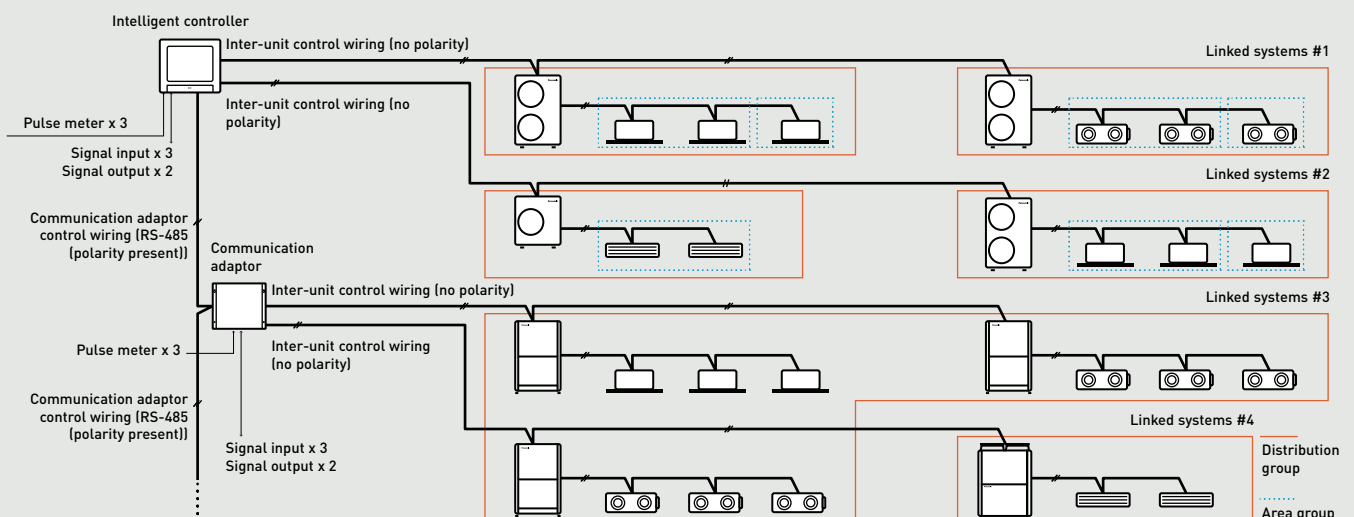

## Local adaptor for ON / OFF control

### CZ-CAPC4

#### Connection with general equipment.

- Control and status monitoring is possible for individual indoor unit (or any external electrical device up to 250 V AC, 10 A) by contact signal
- Up to three digital outputs

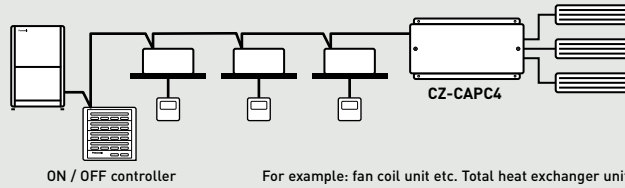

## Demand control for Mini ECOi (LZ2, LE2) outdoor units

### CZ-CAPDC3

#### Connection with general equipment.

- Control of Mini ECOi (LZ2, LE2) outdoor units
- From the central control device, demand control and forced stop are possible

Input: Demand (non-voltage contact / 24 V DC / 2 mA, static signal).  
 Input: Forced stop operation (non-voltage contact / 24 V DC / 10 mA, static signal).  
 Forced stop input for fire alarm input control.  
 3 step demand control for staged control of outdoor unit capacity.

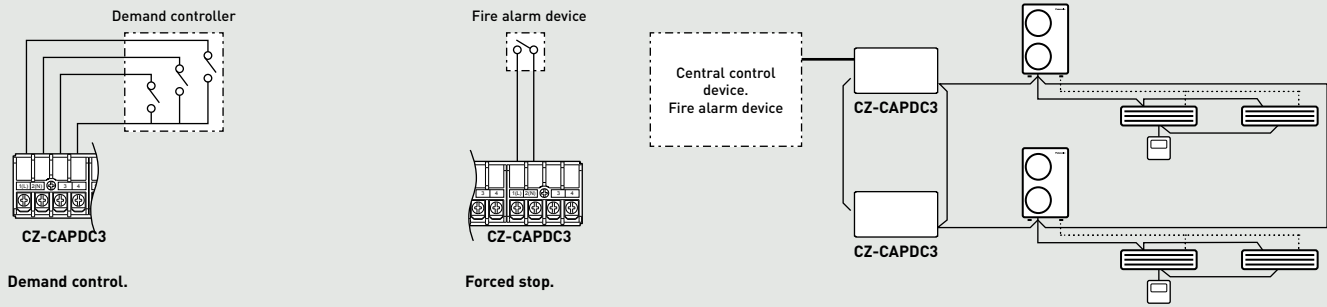

## Mini Seri-Para I/O Unit 0 -10 V

### CZ-CAPBC2

#### Connection with general equipment.

- Control and status monitoring is possible for individual indoor unit (1 group)
- In addition to operation and stop, there is a digital input function for air speed and operation mode
- Temperature setting and measuring of the indoor suction temperature can be performed from central monitoring
- Power is supplied from the T10 terminal of the indoor units
- The analog input for demand of the outdoor capacity by 20 steps (from 40% to 120%) by 0-10 V
- The analog input for temperature setting is 0 to 10 V, or 0 to 140 Ohm
- Separate power supply also is possible (in case of suction temperature measuring)

\*Ask to your distributor.

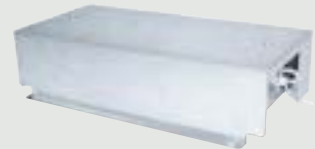
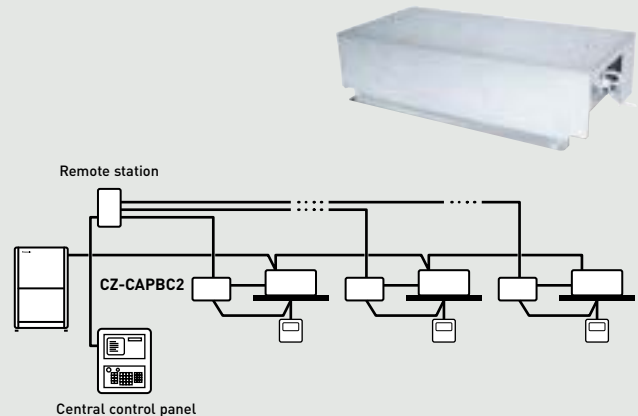

## Communication adaptor for VRF connectivity

### CZ-CFUNC2

This communication interface is required to connect a ECOi system to a BMS. CZ-CFUNC2 is very easy to operate and to connect to the Panasonic S-Link, which is the ECOi bus. From the CZ-CFUNC2, all the indoor and outdoor units of the installation can be easily control. Two linked wiring systems can be connected to one CZ-CFUNC2.

Dimension (HxWxD): 260 x 200 x 68 mm

\*As this is not a splash-proof design, it must be installed indoors or in the control panel, etc.



## PACi NX and VRF connectivity

Controls and connectivities are the key to offer better comfort and price. Panasonic offers its customers cutting-edge technology, specially designed to ensure our air conditioning systems deliver optimal performance.



### PACi NX and ECOi connectivity.

The interface has been designed specifically for Panasonic and provides complete monitoring, control and full functionality of the line-up from IntesisHome, KNX, Modbus and BACnet installations. This connectivity solution with "PAW" model names is made by a third party company, please contact Panasonic for more information.

	Room controller	Interface	BMS Type	Maximum number of indoor units connected
<b>PACi NX / ECOi indoor units</b>	PAW-RE2C4-MOD-WH / PAW-RE2C4-MOD-BK		Modbus	1 unit/group
		PAW-RC2-KNX-1i	KNX	1 (1 group of indoor units)
		PAW-RC2-MBS-1	Modbus RTU <sup>1)</sup>	1 (1 group of indoor units)
		PAW-RC2-MBS-4	Modbus	4 Indoor/groups
		PAW-RC2-BAC-1	BACnet	1
		PAW-AZRC-KNX-1	KNX	1 (1 group of indoor units)
		PAW-AZRC-MBS-1	Modbus RTU <sup>1)</sup>	1 (1 group of indoor units)
		PAW-AZRC-BAC-1	BACnet	1
<b>PACi NX / ECOi S-Link</b>	PAW-AC2-BMS-16		KNX, Modbus and BACnet	16
	PAW-AC2-BMS-64		KNX, Modbus and BACnet	64
	PAW-AC2-BMS-128		KNX, Modbus and BACnet	128

<sup>1)</sup> Interface Modbus RTU/TCP is needed in case if Modbus TCP connection. PAW-MBS-TCP2RTU (ModBus RTU Slave devices).

### Airzone. Control of the hide-aways

Airzone has developed interfaces to easily connect to Panasonic Commercial hide-away units. Ensuring optimum performance, comfort and energy savings, the system is efficient and easy to install.

#### Airzone full range of accessories for any duct project.

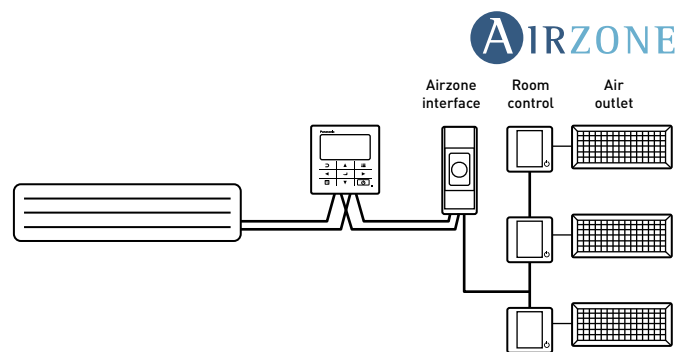

# PACi NX and ECOi connectivity indoor units

## PCB's and cables for PACi NX and ECOi indoor units

Name of the cables	Function	Comment
<b>CZ-T10</b>	All T10 functions	Requires field supplied accessory
<b>PAW-FDC</b>	Operate external fan	Requires field supplied accessory
<b>PAW-OCT</b>	All option monitoring signals	Requires field supplied accessory
<b>CZ-CAPE2</b>	3-Pipe control PCB	Requires additional wires from spare part supply
<b>PAW-EXCT</b>	Forced Thermo OFF/Leakage D	Requires field supplied accessory
<b>PAW-OPT-MZ</b>	Adapter harness for option, fan drive and EXCT functions	Compatible with PACi NX indoor unit types: PK4 and PE4, ECOi indoor unit types: MM2, MK3, MP2, and MR2

Name of the PBC	Function	Comment
<b>PAW-T10</b>	All T10 functions	Allows easy connection "Plug & Play"
<b>PAW-PACR4</b>	PCB for server room application. Available for PACi NX and ECOi	Interface for redundant operation up to 4 indoor unit groups

### T10 connector (CN061)

#### CZ-T10

Panasonic has developed an optional accessory (consisting of plug + wires) called CZ-T10 to enable an easy connection to this T10 connector.



Connecting an ECOi indoor unit to an external device is easy. The T10 terminal featured in the electronic circuit board of all indoor units enables digital connection to external devices.

#### T10 terminal specification (T10: CN061 at indoor unit PCB).

- Control items: 1. Start / stop input
- 2. Remote controller prohibit input
- 3. Start signal output
- 4. Alarm signal output

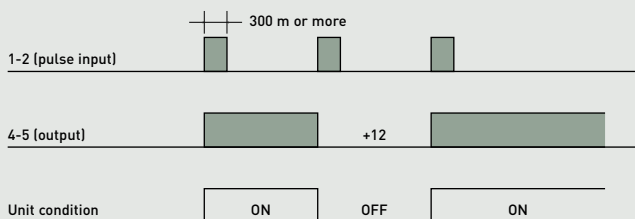

NOTE: The wire length from indoor unit to the relay must be within 2,0 m. Pulse signal changeable to static by cutting jumper JP001.

Condition:

- 1-2 (pulse input): Unit ON / OFF condition switching with a pulse signal. (1 pulse signal: shortage status more than 300 msec. or more)
- 2-3 (static input): open / operation with remote is permitted (normal condition) close / remote controller is prohibited
- 3-4 (static output): 12 V output during the unit ON / no output at OFF
- 4-5 (static output): 12 V output when some errors occur / no output at normal

Example of wiring:

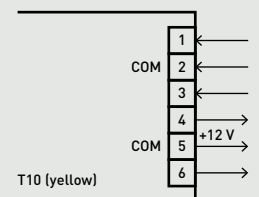

#### Usage example.

##### Forced OFF control.

Term 1 and 2: Free contact for ON / OFF signal (cut \*JP1\* for static signal) when the hotel card is it connected the contact must be close (the unit can be used).

Term 2 and 3: Free contact to prohibit all function in the remote controller install in the room when the hotel card is it removed the contact must be closed (the unit can not work).

Terminal = T10

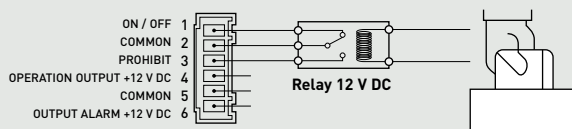

#### Operation ON / OFF signal output.

Condition:

- 4-5 (static output): 12 V output during the unit ON / no output at OFF

Example of wiring:

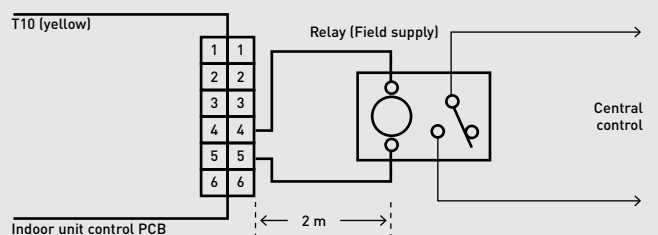

Note: The wire length from indoor unit to the Relay must be within 2,0 m. Pulse signal changeable to static by cutting jumper JP001.

\*PACi NX Series is not compatible.

### Fan drive connector (CN032)

#### PAW-FDC

Panasonic has developed an optional accessory (consisting of plug + wires) called PAW-FDC to enable an easy connection to this fan drive connector (CN032).

- Operating the ventilation fan from the remote controller
- Start / stop of external ventilation and total heat exchanger fans
- Works even if indoor unit is stopped
- In case of group control > all fans will operate; no individual control

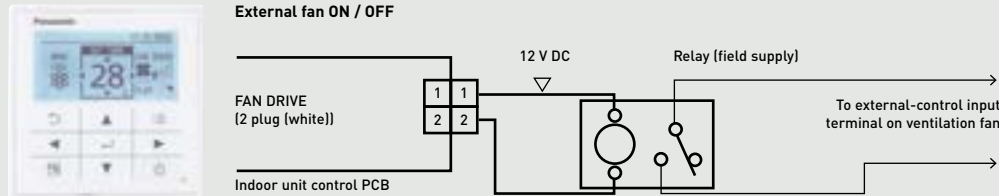

### Option connector (CN060) output external signals

#### PAW-OCT

Panasonic has developed an optional accessory (consisting of plug + wires) called PAW-OCT to enable an easy connection to this Option Connector (CN060).

With the combination of the T10 and the option CN060 an external control of the indoor units is possible!

6P (white): Outputs external signals as shown in the figure below.

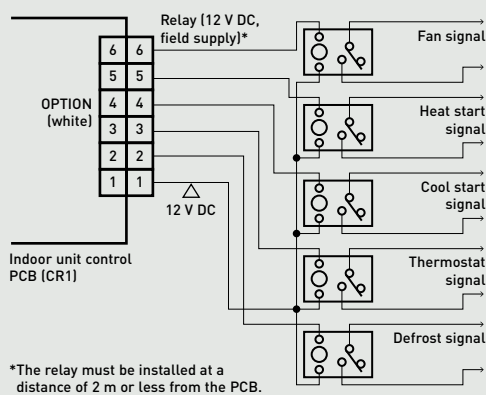

\*The relay must be installed at a distance of 2 m or less from the PCB.

### EXCT connector (CN073)

#### PAW-EXCT

Panasonic has developed an optional accessory (consisting of plug + wires) called PAW-EXCT to enable an easy connection to this EXCT Connector (CN073).

#### A) With static input.

##### > STATIC INPUT > THERMO OFF > ENERGY SAVING

2P plug (red): Can be used for demand control. When input is present, forces the unit to operate with the thermostat OFF.

Note: The length of the wiring from the indoor unit control PCB to the relay must be 2 m or less.

Examples of wiring:

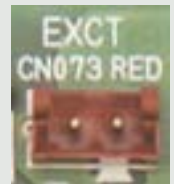
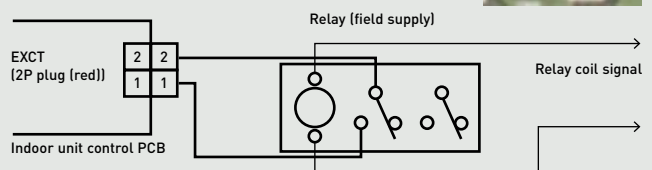

#### B) Example: In connection with a refrigerant sensor.

- Signal from leakage detector: non voltage, static.
- Indoor unit setting: Code 0b > 1
- Connector for leak detector: EXCT
- Outdoor unit setting: Code C1 > 1 power output if alarm from O2 connector 230 V Code C1 > 2 power output if alarm from O2 connector 0 V
- Displayed alarm message P14

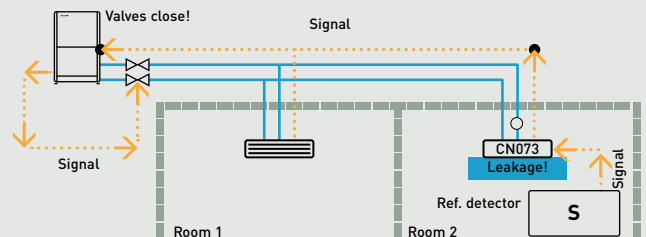

### Option harness

#### PAW-OPT-MZ

Adapter harness to allow connection of PAW-OCT and PAW-FDC, to provide option, fan drive, EXCT functions.

For PACi NX indoor unit types: PK4 and PE4.

For ECOi indoor unit types: MM2, MK3, MP2, and MR2.

