

AQUAREA

## Aquarea Heat Pumps: efficient comfort for every project

From 3 kW to 30 kW, Panasonic's Aquarea air to water heat pumps range is one of the widest on the market, designed for both new builds and refurbishments. With multiple All in One units, cascade controllers, and indoor comfort solutions, Aquarea delivers energy savings and comfort for every project, from single homes to centralised systems.



## ABOUT

Highlighted features	→ 3
Discover the Aquarea Heat Pump range	→ 5
Comfort heating and peace of mind with Aquarea solution	→ 7
At the forefront of heating innovation: Panasonic Aquarea with natural refrigerant R290	→ 9
<hr/>	
Aquarea M Series	→ 11
Aquarea All in One Hydraulic M Series	→ 14
Aquarea T-CAP M Series	→ 15
Big Aquarea T-CAP M Series	→ 16
Big Aquarea for centralised heating and DHW	→ 17
Aquarea K Series	→ 19
<hr/>	
Aquarea Loop	→ 21
<hr/>	
Aquarea EcoFleX	→ 23
<hr/>	
Smart Solutions for Aquarea systems	→ 27
Aquarea Home App	→ 28
Panasonic Comfort Cloud App	→ 29
Aquarea Service Cloud	→ 30
Aquarea Heat Pumps + tado°	→ 31
Control and connectivity	→ 33
Cascade manager	→ 35
P-Smart Edge for Aquarea Cascade Edge	→ 37
<hr/>	
How Panasonic contributes to Nearly Zero Energy Buildings (nZEB)	→ 39
Aquarea and PV integration	→ 40
Aquarea design tools to make your life easier	→ 41
<hr/>	
Validating efficiency and performance of Aquarea Heat Pumps	→ 52
<hr/>	
Features explained	→ 133
<hr/>	
Examples of installations	→ 134
<hr/>	
<b>Aquarea range</b>	
Aquarea Hydraulic	→ 43
Aquarea Split	→ 45
Aquarea DHW Heat Pump	→ 46

## PRODUCT SPECIFICATIONS

**Aquarea T-CAP**

Hydraulic M Series · R290	→ 47
Mono-bloc J Series - MXC · R32	→ 51
All in One 185 L K Series · R32	→ 59
All in One 185 L K Series with Electrical Anode · R32	→ 60
All in One 260 L K Series · R32	→ 61
All in One 260 L K Series with Electrical Anode · R32	→ 62
All in One 185 L K Series. Super Quiet outdoor unit · R32	→ 63
All in One 185 L K Series with Electrical Anode. Super Quiet outdoor unit · R32	→ 64
All in One 260 L K Series. Super Quiet outdoor unit · R32	→ 65
All in One 260 L K Series with Electrical Anode. Super Quiet outdoor unit · R32	→ 66
Bi-bloc K Series · R32	→ 67
Bi-bloc K Series. Super Quiet outdoor unit · R32	→ 68

**Aquarea High Performance**

Hydraulic L Series · R290	→ 53
Hydraulic M Series · R290	→ 55
Mono-bloc J Series - MDC · R32	→ 58
All in One 185 L K Series · R32	→ 69
All in One 185 L K Series with Electrical Anode · R32	→ 70
All in One 260 L K Series with Electrical Anode · R32	→ 71
All in One 185 L K Series 2 zones · R32	→ 72
All in One 185 L K Series · R32	→ 73
All in One 185 L K Series with Electrical Anode · R32	→ 74
All in One 260 L K Series · R32	→ 75
All in One 260 L K Series with Electrical Anode · R32	→ 76
Bi-bloc K Series - SDC · R32	→ 77

**Aquarea EcoFleX · R32****Aquarea Loop****Aquarea Air Smart fan coils**

Floor standing	→ 85
Wall-mounted	→ 86
Ducted thin / ducted	→ 87
Ducted multi zone thin / ducted multi zone	→ 89

**Flex Air Smart fan coil**

Wall-mounted DC fan – FK1	→ 91
Medium static pressure duct DC fan – FF1	→ 93
Comfort AC/EC fan	→ 95

**More options for your home**

Storage tanks for heating and DHW	→ 99
Heat recovery ventilation unit	→ 101
Aquarea Vent - Counter flow ventilation	→ 103
Aquarea DHW Heat Pumps	→ 105

Accessories and control	→ 107
-------------------------	-------

Heating and cooling capacity tables	→ 123
-------------------------------------	-------

## Highlighted features

From 3 kW to 30 kW, Panasonic Aquarea Heat Pumps offer one of the widest ranges on the market, suitable for both new builds and refurbishment projects. Developed for high system efficiency, installation flexibility and long-term operational reliability.



**Developed and manufactured by Panasonic, the Aquarea range combines advanced heat pump technology with over 65 years of HVAC engineering expertise.**

Aquarea Heat Pumps integrate exclusive Panasonic technologies such as T-CAP for reliable capacity at low outdoor temperatures, U-Vacua™ insulation to minimise heat loss, and in-house developed Panasonic compressors engineered for efficiency, durability and quiet operation.

**Reliable performance at extremely low outdoor temperatures.**

Panasonic Aquarea is engineered for stable operation at outdoor temperatures as low as -25 °C, ensuring consistent system performance while reducing energy consumption and CO<sub>2</sub> emissions.

 **UP TO 80% ENERGY SAVING COMPARED TO BOILERS**

 **RELIABLE COMFORT IN EXTREME OUTDOOR CONDITIONS**

**CO<sub>2</sub> / LOWER CO<sub>2</sub> EMISSIONS**

Aquarea – a comprehensive heating solution by Panasonic.

Panasonic extends its commitment to comfort and energy savings beyond heat pumps by offering a comprehensive range of solutions for indoor comfort.



# Discover the Aquarea Heat Pump range

## Aquarea Hydraulic systems

The Aquarea Hydraulic system simplifies installation by requiring only water pipes between the outdoor unit and the interior of the building.

No F-gas certification required

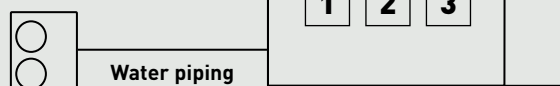

## Hydraulic indoor unit options

### 1 Stand-alone outdoor unit + optional DHW tank.

This hydraulic system without indoor unit offers high installation flexibility, ideal for retrofit projects.

### 2 All in One indoor unit.

The All in One unit combines the indoor unit and a DHW tank, simplifying installation and saving space.

### 3 Bi-bloc indoor unit + optional DHW.

This wall-mounted unit offers flexible installation with customizable tank sizes.



		5,0 kW	7,0 kW	9,0 kW	12,0 kW	16,0 kW	20,0 kW	25,0 kW	30,0 kW
Aquarea High Performance	1 ph	✓	✓	✓	✓	✓			
	3 ph			✓	✓	✓			
Aquarea T-CAP	1 ph			✓	✓				
	3 ph			✓	✓	✓	✓	✓	✓

## Aquarea DHW Heat Pumps

Using a compressor with natural refrigerant R290, Aquarea DHW Heat Pumps efficiently produce domestic hot water and significantly reduce energy consumption and CO<sub>2</sub> emissions compared to electric heaters and other traditional systems.



Panasonic Aquarea provides the ideal solution for any project, enhancing the efficiency of homes and simplifying the installation process.

### Aquarea Split systems

The Aquarea split system features a separate outdoor unit and indoor unit connected by refrigerant pipes. It requires no antifreeze protection for outdoor piping, even during long periods of inactivity in cold climates.

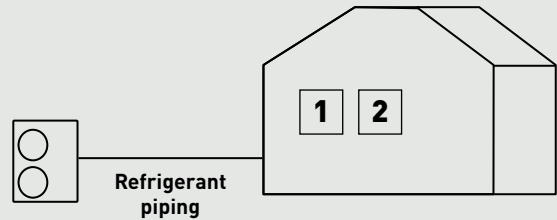

### Indoor unit options

**1 All in One indoor unit.**

The All in One unit combines the indoor unit and a DHW tank, simplifying installation and saving space.

185 L - 260 L



**2 Bi-bloc indoor unit + optional DHW.**

This wall-mounted unit offers flexible installation with customizable tank sizes.



		3,0 kW	5,0 kW	7,0 kW	9,0 kW	12,0 kW	16,0 kW
Aquarea High Performance	1 ph	✓	✓	✓	✓	✓	✓
	3 ph				✓	✓	✓
Aquarea T-CAP	1 ph				✓	✓	
	3 ph				✓	✓	✓

### Aquarea EcoFleX

Designed for new installations, the Aquarea EcoFleX heat pump combines air to air indoor units and a hot water tank. It delivers hot water, heating, cooling, and cleaner air, all with outstanding efficiency, energy savings, and low CO<sub>2</sub> emissions.

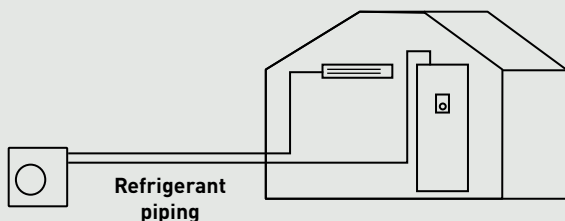

# Comfort heating and peace of mind with Aquarea solution

## Aquarea Air Smart fan coils.

Stylish, compact fan coil units for high comfort and energy savings.

**Aquarea Air Smart fan coil – Floor standing.**  
Even narrower and thinner fan coils.



**Aquarea Air Smart fan coil – Wall-mounted.**  
The thinnest and most quietest in its class.

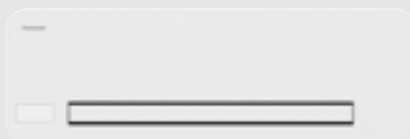

**Aquarea Air Smart fan coil – Ducted / ducted multi zone.**  
Thin version with only 185 mm height.  
Integrated multi zone management (2-5 zones, with the multi zone line-up).



## Flex Air / Flex Air Smart fan coils.

A large range of fan coil units dedicated to commercial applications.

**Flex Air Smart fan coil – Wall-mounted – FK1.**  
Stylish design. nanoe™ X (Generator Mark 3).

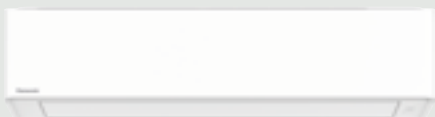

**Flex Air Smart fan coil – Medium static pressure duct – FF1.**  
nanoe™ X (Generator Mark 3).



**Flex Air fan coil – Comfort.**  
Floor and ceiling units with high configuration flexibility.



Panasonic extends its commitment to comfort and energy savings beyond heat pumps by offering a comprehensive range of solutions for indoor comfort.

### Aquarea Loop, the water loop heat pump for multi-family buildings.

Efficiently replaces existing radiators in centralised heating systems.



### Wide range of water tanks DHW tanks, buffer tanks and combo tanks available.



### Residential ventilation units.

**Aquarea Vent – Counter flow ventilation units.**  
Suitable for single family houses or apartments.  
High-efficiency sensible heat recovery.



**Heat recovery ventilation unit.**  
Designed for areas up to approximately 140 m<sup>2</sup>.  
High energy-efficiency rotary heat exchanger with EC technology fans.



### tado° for room heating control and smart energy management services.

Unlocking maximum efficiency and savings – without sacrificing cosy temperatures at any time.

tado° smart heating customers save an average of 22% on their energy consumption.

\*Based on internal data averaged across all tado° customers, collected up to 11/2023.



### Cascade solutions.

Boost the capacity up to 300 kW by connecting the Aquarea Heat Pumps in cascade.



### Aquarea Service Cloud.

For remote maintenance of the Aquarea Heat Pump.



# At the forefront of heating innovation: Panasonic Aquarea with natural refrigerant R290

Aquarea air to water heat pumps with R290 refrigerant offer an advanced, energy efficient solution for heating, cooling, and domestic hot water that delivers outstanding performance, aligning with our vision of a carbon-free society and our GREEN IMPACT plan.



**0,02** Global Warming Potential

Panasonic's newest series are engineered with industry leading natural refrigerant R290, which has a low Global Warming Potential (GWP) of just 0,02, helping reduce CO<sub>2</sub> emissions and environmental impact.

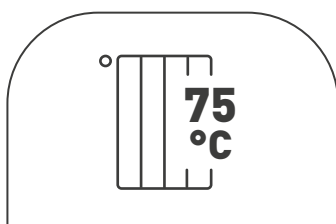

**Output water.**

Up to 75 °C water outlet down to -15 °C\* outdoor.

\*-10 °C for L Series. Down to 15 °C outdoor for 20, 25 and 30 kW models.

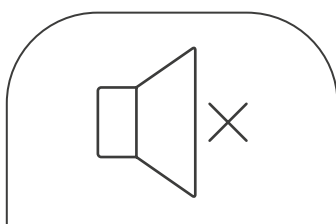

**Quiet operation.**

Only 27 dB(A) sound pressure at 5m\*.

\*Sound pressure calculation for WH-WDG05LE5, free standing, A +7 °C, W 35 °C in Quiet mode 3.

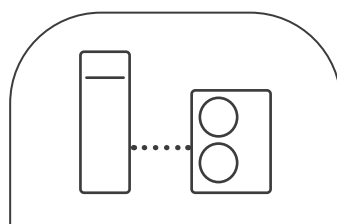

**Flexible hydronic installation.**

Hydronic connection between indoor and outdoor.

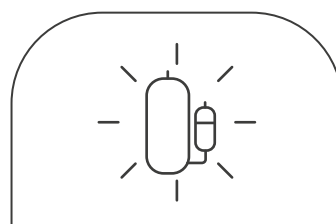

**Made and designed by Panasonic.**

Reliable outdoor units with Panasonic compressor.

**Output water. High performance under extreme conditions**

**Excellent solution for heating system retrofit.**

The compressor operates without backup heating down to -28 °C ambient temperatures, and can be integrated alongside existing radiators with a high-water flow temperature of up to 75 °C at -15 °C outside temperature. Even at -28 °C outside temperature, it can supply hot water at 55 °C.

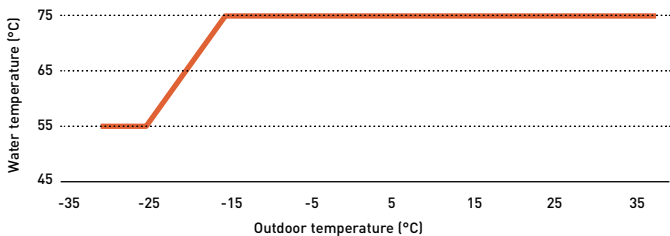

\*For M Series T-CAP 9, 12 and 16 kW models. M Series High Performance operates down to -25 °C with 75 °C water outlet down to -15 °C ambient. L Series operates down to -25 °C with 75 °C water outlet down to -10 °C ambient.

**Sterilisation process without heater.**

It can also reach a domestic hot water temperature of up to 65 °C without the use of the electric heater, so the tank sterilisation can be performed with the heat pump operation.

**Quiet operation. Panasonic's unique low noise architecture**

The compressor, which is a major source of noise, is equipped with a double-bottomed structure to provide a safe, quiet structure that does not disturb neighbours in crowded residential areas.

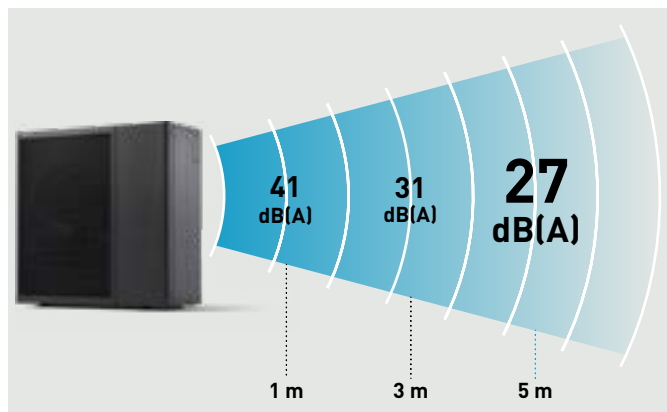

\*Sound pressure calculation for WH-WDG05LE5, free standing, A +7 °C, W 35 °C in Quiet mode 3.



**Flexible hydronic installation**

The installation of the system is 100% hydronic, with only water pipes between the outdoor unit and the interior of the home.

**More living space at home.**

No indoor safety measures needed for refrigerant or fuel gas piping.

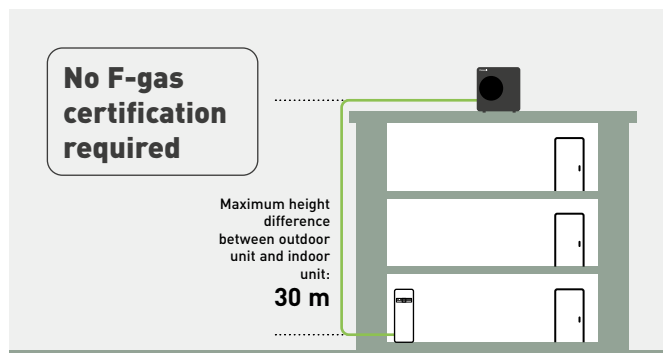

\*For L Series only when the outdoor unit is installed above the indoor unit, and the water pressure does not exceed 1 bar at the outdoor unit.

**Made and designed by Panasonic.**

**Aquarea High Performance L Series from 5 to 9 kW.**



Wi-Fi adapter included

**Aquarea High Performance M Series from 9 to 16 kW.  
Aquarea T-CAP M Series from 9 to 30 kW.**



Wi-Fi adapter included

\*Check availability of units and combinations.

# Aquarea M Series, the latest generation of high performance heat pumps with R290

Combining flexible system design, quiet operation and up to 75 °C water flow, the Aquarea M Series offers a reliable, high-quality heat pump solution for new-build and retrofit applications.



reddot winner 2024



GOOD DESIGN AWARD 2024

**BEST 100**

\*For 9, 12 and 16 kW single and three phase.

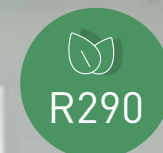

Up to 75 °C water outlet down to -15 °C outdoor\*.

\*Down to 15 °C outdoor for 20, 25 and 30 kW models.



Only 29 dB(A) sound pressure at 5 m\*.

\*Sound pressure calculation for WH-WXG12ME5, free standing, A +7 °C, W 35 °C in Quiet mode 3.



Hydronic connection between indoor and outdoor.



Reliable outdoor units with Panasonic compressor.

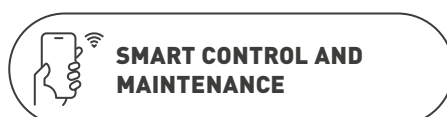

Panasonic Comfort Cloud App and Aquarea Service Cloud included.



ErP 35 °C.  
Energy efficiency class up to A+++\*.

\*Scale from A+++ to D.

**Flexible installation, suitable for retrofit and new buildings.**

Thanks to its new, modular concept, the outdoor unit can function independently with just an indoor remote control, for those seeking basic functionalities. Homeowners can opt for enhanced functionality by incorporating the more advanced control module or selecting between a Bi-bloc or All in One indoor units.



Available in 120 L, 185 L and 260 L DHW tank.



	Remote controller	Control module	Bi-bloc (available from 9 to 16 kW)	All in One (available from 9 to 16 kW)
<b>CN-CNT</b>	☐ (1)	☐ (2)	☐ (2)	☐ (2)
<b>Backup heater</b>	—	Field supply	☐	☐
<b>Expansion vessel (10 L)</b>	—	—	☐	☐
<b>Additional functions</b>	—	CZ-NS7P	CZ-NS6P	CZ-NS6P

**Output water. High performance under extreme conditions**

**Excellent solution for heating system retrofit.**

The compressor operates without backup heating down to -28 °C\* ambient temperatures, and can be integrated alongside existing radiators with a high-water flow temperature of up to 75 °C at -15 °C outside temperature. Even at -28 °C\* outside temperature, it can supply hot water at 55 °C.

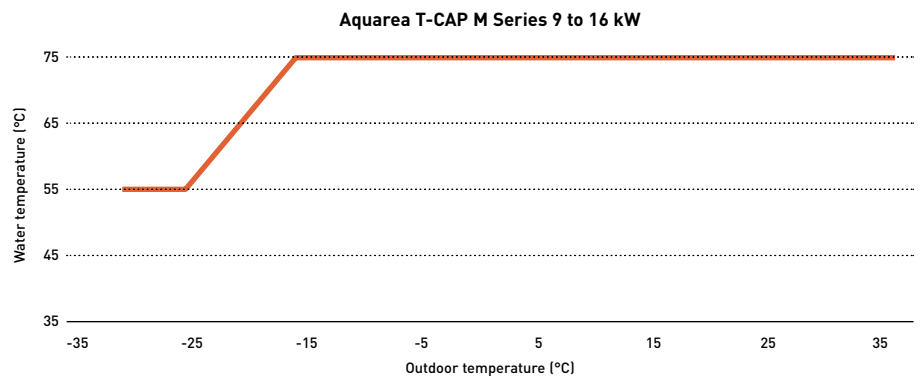

\*For M Series T-CAP (WH-WXG\*\*). In case of M Series High Performance (WH-WDG\*\*) operation down to -25 °C.

**High energy efficiency in heating and domestic hot water**

The Aquarea M Series saves energy and significantly reduces operating cost by achieving the highest ErP energy rating. Aquarea M Series can reach a domestic hot water temperature of up to 65 °C without the use of the electric heater, so the tank sterilisation can be performed with the heat pump operation for further energy savings.

\*Rating conditions: Heating: Inside air temperature: 20 °C Dry Bulb / Outside air temperature: 7 °C Dry Bulb / 6 °C Wet Bulb. Conditions: Water input temperature: 30 °C / Water output temperature: 35 °C. Energy rating for WH-WXG12ME8.

**A+** ENERGY EFFICIENCY CLASS UP TO A+. SCALE FROM A+ TO F.

**A+++** **A++** ERP 35 °C / 55 °C. ENERGY EFFICIENCY CLASS UP TO A+++/A++. SCALE FROM A+++ TO D.

**Great serviceability**

Cutting-edge outdoor unit design keeps the PCB in a safe and accessible location.

**Aquarea M Series safety optimisation.**

- 1 | Non-flammable control box
- 2 | Power box cable gland with sealed connections
- 3 | Air/refrigerant separator

\*This image applies to 9, 12 and 16 kW.

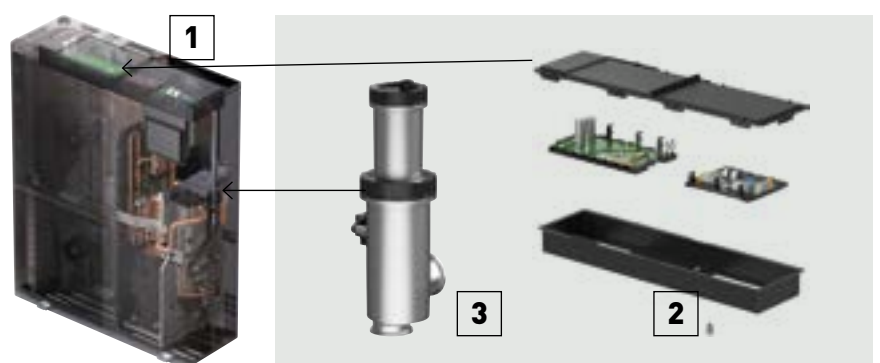

# Enhanced comfort and advanced connectivity with the Aquarea M Series

**Aquarea M Series delivers a revolution in the design, performance and connectivity, aligning with our vision of a carbon-free society and our GREEN IMPACT plan.**

## Maximising hot water comfort.

- Up to 40% more tap water with a higher tank temperature setting to save space
- New domestic hot water circulation mode for instant availability of hot tap water
- During sterilisation, the domestic hot water circulation mode is activated to ensure sterilisation of the water pipes

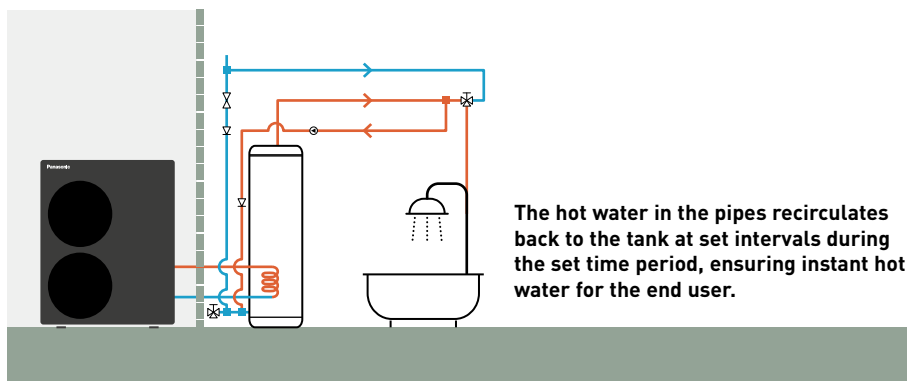

## Internet adapter included for Smart Control and remote maintenance

The Aquarea M Series comes standard with an internet adapter for Wi-Fi or WLAN connection. It can be easily connected via the front panel of the indoor units or the control module, providing flexible and intuitive connectivity.



## Advanced control and connectivity features, enhanced interface.

### Smart bivalency.

Cost effective bivalent mode with power tariff logic.

### Smart Grid Ready.

The Aquarea M Series features the SG Ready function\* for seamless connection to smart grid controls.

### Enhanced connectivity.

A second interface connection port (CN-CNT) offers improved connectivity when connecting the outdoor unit to the control module or an indoor unit.

\*Additional accessory required.

### BMS integration.

Aquarea integrates seamlessly with Modbus or KNX projects\*, allowing bi-directional monitoring and control of all operating parameters.

### Dual controller system.

A dual controller system, for independent control of two zones, within the home.

\*Additional accessory required.



# Aquarea All in One Hydraulic M Series

The ultimate space saving solution.

Available in 120 L, 185 L and 260 L DHW tank, with a footprint of just 599 x 602 mm.



**599 X 602 MM FOOTPRINT REDUCES REQUIRED INSTALLATION SPACE**



**NO BUFFER TANK REQUIRED, REDUCING SPACE, COST AND INSTALLATION TIME**



**UP TO 40% MORE TAP WATER WITH A HIGHER TANK TEMPERATURE SETTING**



**ROBUST BODY AND TOP SURFACE ENABLES INSTALLATION OF A TOP VENTILATION UNIT**

## Aquarea All-in-One M series: the best Panasonic technology.



### Great serviceability.

- Easy access to hydraulic part thanks to door opening mechanism
- All sensors can be checked from the remote controller
- Water pressure sensor and reading on home-screen

### Other high quality components inside.

- Maintenance free Inox stainless 120 L, 185 L or 260 L tank
- Variable speed water pump ("A class")
- Backup heater
- 3 way valve inside



### Extended elevation difference (up to 30 m).

With the new expansion vessel, the All in One M Series allows a high indoor/outdoor height difference of up to 30 m.

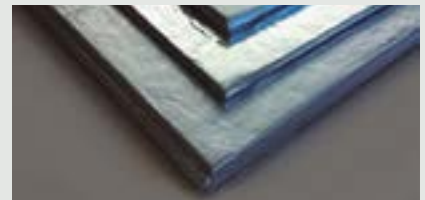

### U-Vacua™ Vacuum insulation panel.

U-Vacua™ panels offer 19 times the insulation performance of polystyrene foam. Since the system retains heat longer, it needs to heat up fewer times each day, resulting in energy savings.

## Aquarea All in One with Electrical Anode:

The All in One with built-in impressed current anode is the ideal solution for installations in locations with harsh water conditions.

\*Available only on models with a 185 L or 260 L DHW tank.



# Aquarea T-CAP M Series: Designed for demanding conditions, powered by natural refrigerant R290

Introducing T-CAP M Series, innovative Aquarea Heat Pumps with natural refrigerant R290, delivering superior performance even in extreme conditions.



Aquarea T-CAP outdoor units are highly reliable thanks to the quality of all components, including the new compressor with injection technology, developed and manufactured by Panasonic, that can work in outdoor temperatures as low as -28 °C.

**75 °C OUTPUT WATER**

Up to 75 °C water outlet down to -15 °C outdoor\*.

\*Down to 15 °C outdoor for 20, 25 and 30 kW models.

**QUIET OPERATION**

Only 29 dB(A) sound pressure at 5 m\*.

\*Sound pressure calculation for WH-WXG12ME5, free standing, A +7 °C, W 35 °C in Quiet mode 3.

**-28 °C EXTREME CONDITIONS**

Compressor operating down to -28 °C outdoor temperatures.

**-15 °C T-CAP TECHNOLOGY**

Keeping heating capacity down to -15 °C at 55 °C water outlet.

## Aquarea T-CAP, high performance whatever the climate

With Aquarea T-CAP technology and the new compressor with Injection technology, Panasonic heat pumps can work in outdoor temperatures as low as -28 °C and maintain capacity without backup heating at -15 °C\*.

\*WH-WXG20/25/30ME8 work down to -25 °C outdoor.

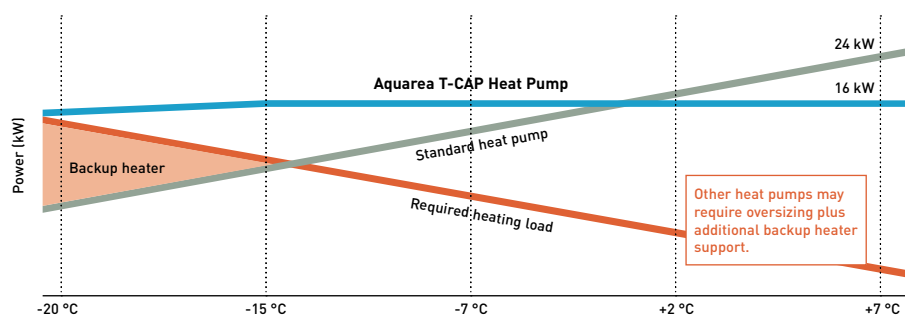

## Quiet operation. Panasonic's unique low noise architecture

The compressor, which is a major source of noise, is equipped with a double-bottomed structure to provide a safe, quiet structure that does not disturb neighbours in crowded residential areas.

\*Sound pressure calculation for WH-WXG12ME8, free standing, A +7 °C, W 35 °C in Quiet mode 3.

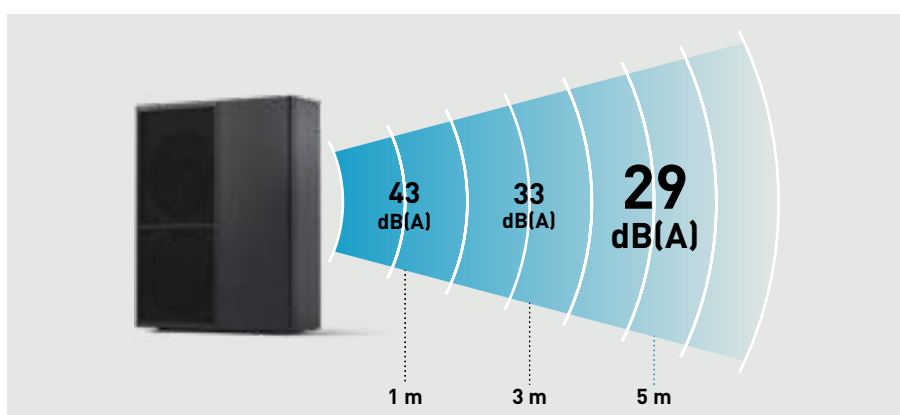

# Big Aquarea T-CAP M Series, the ideal solution for centralised heating and DHW installations

The Big Aquarea M Series offers a flexible, compact and energy efficient solution for central heating and/or domestic hot water installations in multi-family or commercial buildings.

## T-CAP technology, stable operation and high performance under extreme conditions.

The solution is suitable for both new buildings and retrofits, as it offers a more sustainable alternative to traditional fossil fuel heating systems and it can be easily integrated with existing water system such as fan coils, floor heating or domestic hot water tanks.



**300kW UP TO 300 KW IN CASCADE**



**COMPACT SOLUTION WITH SMALL FOOTPRINT**



**KEEPING CAPACITY AT 55 °C WATER OUTLET DOWN TO -15 °C OUTDOOR**



**QUIET OPERATION**



**PANASONIC INVERTER COMPRESSOR**



**65 °C DHW AT 65 °C WITH COMPRESSOR ONLY**

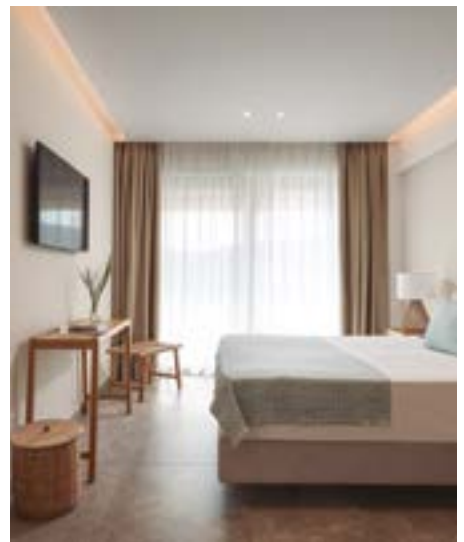

- Units from 20 to 30 kW, up to 300 kW in cascade
- Easy replacement of other heating sources
- Flexible control options: remote control only or control module for enhanced functionality
- Seamless Modbus integration
- Designed to blend with architecture and environment

**Maintained capacity.**  
**Time-saving installation.**  
**Cost-saving.**  
**Space saving.**

**2x 20 kW heat pump**  
Conventional cascade system

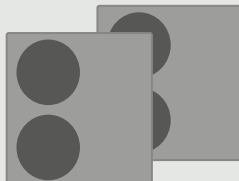

**1x 30 kW\***  
Big Aquarea T-CAP M Series

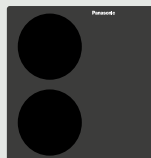

\*For 30 kW demand at 55 °C water outlet and -7 °C outdoor temperature.

### Reliable technology.

The outdoor units are equipped with a Panasonic R290 scroll compressor. The compressor is manufactured in-house with T-CAP technology including injection. The outdoor heat exchanger is protected with a Bluefin treatment for harsh ambient conditions.

# Big Aquarea for centralised heating and DHW installations in multi-family or commercial buildings

The Big Aquarea M Series offers a flexible, compact and energy efficient solution for central heating and/or domestic hot water installations in multi-family or commercial buildings.

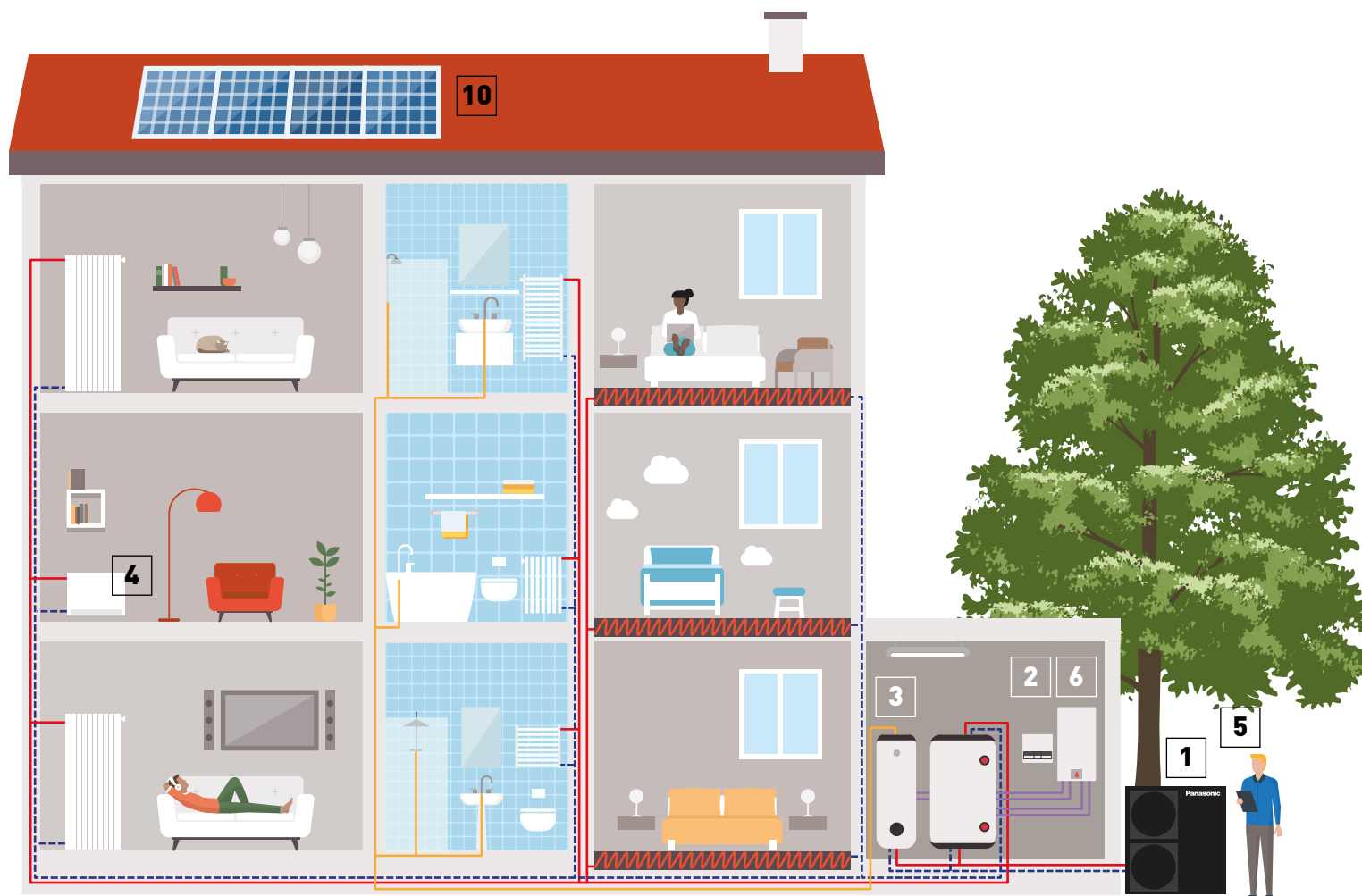

## 1 Big Aquarea T-CAP M Series.

25 kW heat pumps in cascade, for a space saving solution. It can replace an old fossil fuel boiler.



## 2 M Series control module.

The control module allows for enhanced control functionality. Operation with the remote controller only is also possible.



## 3 High-efficiency DHW tank.

A high-efficiency tank provides the required volume of hot water, at the correct temperature, reducing energy costs.



## 4 Aquarea Loop.

The water loop heat pump provides heating and cooling for every apartment or room connected to a central water loop.



## 4 Fan coils, radiators or floor heating.

Aquarea Heat Pumps can be integrated into a new or existing water system.



## 5 Aquarea Service Cloud.

This IoT solution provides powerful and user-friendly management and monitoring of Aquarea Heat Pumps and enables remote maintenance.

**A revolution in the design, performance, connectivity, and sustainability.**

- Scalable solution, up to 300 kW in cascade
- Suitable for new build and retrofit
- Up to 75 °C water outlet
- Easy replacement of other heating sources and integration into existing water systems
- Quiet operation
- Maintains output at 55 °C down to -15 °C
- Hot water production at 65 °C with compressor only
- Flexible control options and seamless Modbus integration

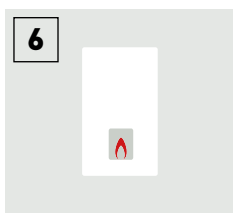
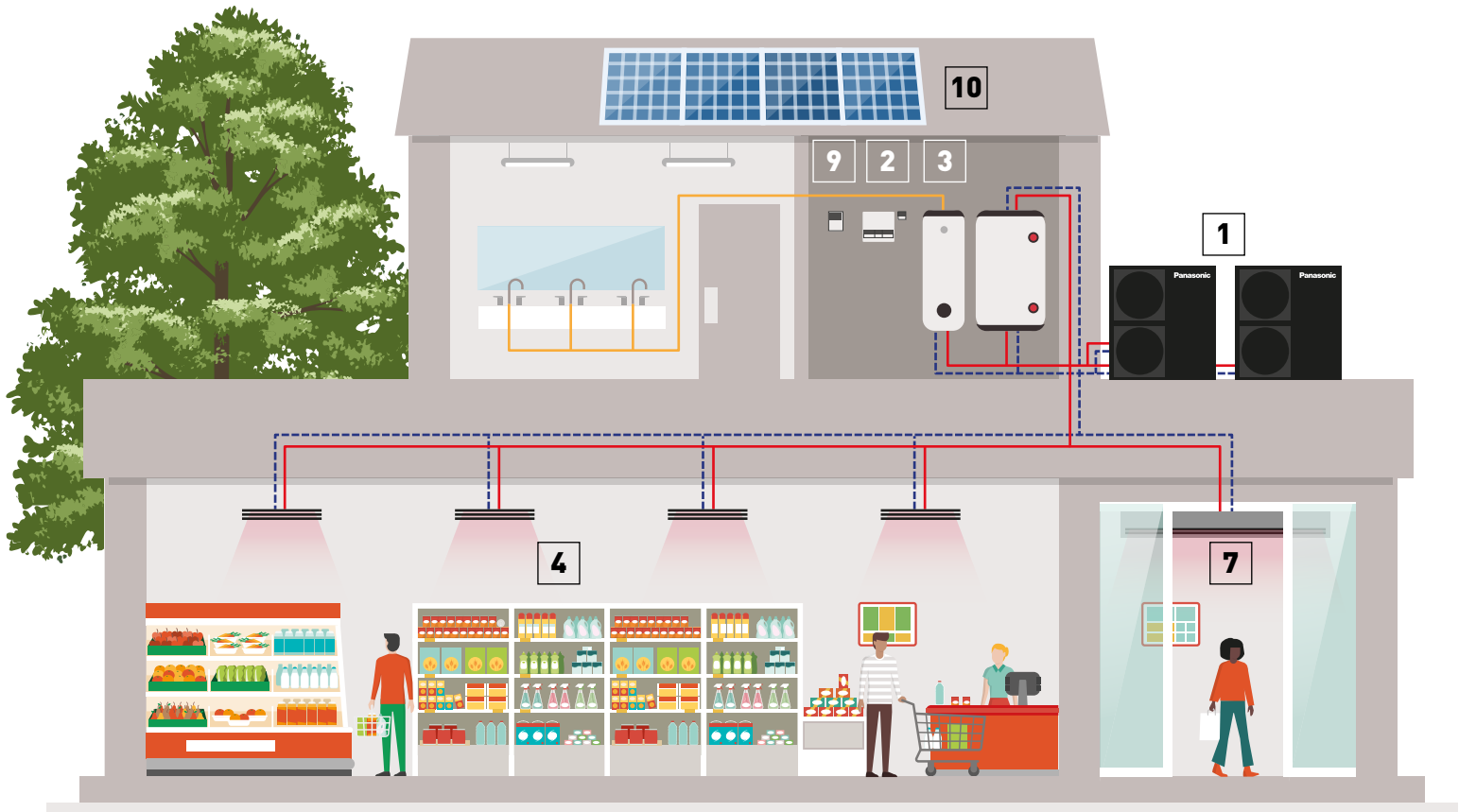

**6**  
**OPTIONAL. Bivalent mode.**  
Cost-effective bivalent mode with energy tariff logic when combined with an existing boiler.



**7**  
**Air Curtain with water Coil.**  
Water coil air curtains can be used in the hydraulic system to have efficient performance of the water system.



**8**  
**BMS integration.**  
The system can be easily integrated into a Modbus project with the optional accessory.



**9**  
**Cascade manager.**  
Manages up to 10 Aquarea Heat Pumps, balancing working hours, can control up to 2 buffer tanks and integrates PV, among others.

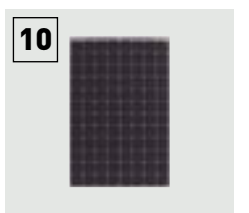

**10**  
**Photovoltaics.**  
Thanks to the integration with PV, the demand or power consumption for heating or hot water production is adapted to the PV production.

**Commercial Smart Edge.**

Manage the entire Panasonic HVAC portfolio from a single platform – on-site or remotely, 24/7.



P-SMART EDGE



P-Smart Nexus

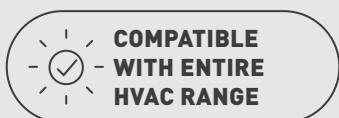

# Aquarea K Series

A revolution in design, efficiency, connectivity and sustainability.

Aquarea K Series is a ground breaking low-energy system for heating, cooling and domestic hot water production that delivers outstanding performance. This model is ideal for new installations and well-insulated homes.

R32  
REFRIGERANT



reddot winner 2023



GOOD DESIGN AWARD 2022

**BEST 100**



Wide range to suit all homes: High Performance and T-CAP.



-8 dB(A) in Quiet mode.



Panasonic Comfort Cloud App and Aquarea Service Cloud.



High energy class for low temperature applications\*.

\*Scale from A+++ to D. Might not apply to all the models.



DHW COP up to 3,5\*.

\*Scale from A+ to F.



Up to 60 °C water outlet down to -10 °C outdoor.

## Further advanced features:

- High tank insulation performance thanks to U-Vacua™\*
- All in One indoor unit available in 185 L and 260 L
- Less frequent maintenance with pre-installed magnet filter
- Water pressure sensor built-in

- Easy access to hydraulic parts
- Operation without backup heater at -25 °C
- Bluefin treatment protection on outdoor heat exchanger for harsh ambient conditions

\*Only applicable to ALL in One indoor unit. U-Vacua™ is a vacuum insulation panel (VIP) technology.

## Aquarea K Series keeps 60 °C water outlet temperature even at very low temperatures

Aquarea K Series is able to keep 60 °C water outlet temperature in outdoor temperatures down to -10 °C, keeping high comfort in the room even at low temperatures. With other heat pumps, water temperature dramatically drops at low outdoor temperatures, making the heat pump to work out of the design conditions and creating discomfort inside the room.

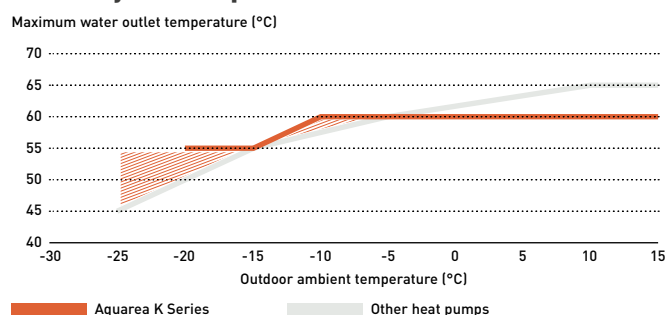

**Aquarea K Series for every project need.**

Available in both T-CAP and High Performance, the Aquarea K Series offers a versatile range of solutions to suit different project sizes and needs.



**The outdoor unit is designed to harmonize with architecture and the environment.**

The compressor, which is a major source of noise, is equipped with a double-bottomed structure to provide a safe, quiet structure that does not disturb neighbours in crowded residential areas.

**-8 dB(A) in Quiet mode**

**Aquarea T-CAP K Series.**

**For retrofit and new builds, the ideal solution for those installations where the output capacity is demanding.**

The entire Aquarea T-CAP line-up is excellent for replacing gas or oil boilers and for connecting to new underfloor heating, radiators or fan coil units.

Aquarea T-CAP can maintain the rated heating capacity even at -15 °C outdoor temperature, without requiring an electrical heater. This makes it an ideal solution for locations with extremely low temperatures

**Aquarea T-CAP, high performance whatever the climate**

With Aquarea T-CAP technology, Panasonic heat pumps can work in outdoor temperatures as low as -28 °C and maintain capacity without backup heating at -15 °C.

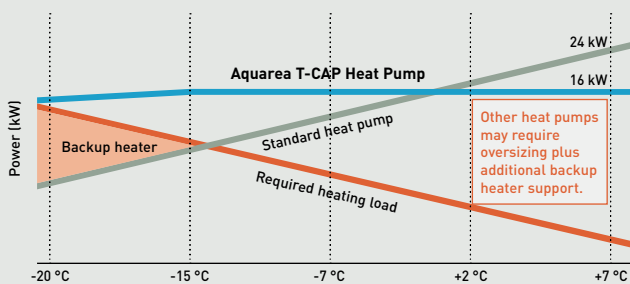

**How Aquarea T-CAP K Series maintains performance even at -15 °C outdoors**

A patent has been obtained for technology that can maintain heating capacity even in low outdoor temperatures through optimal control that comes from incorporating dual-piped heat exchanger into the refrigeration cycle.

**Dual-piped heat exchanger.**

Low pressure and low-temperature refrigerant in the inner pipe.

Image of the Aquarea T-CAP J Series Mono-bloc.

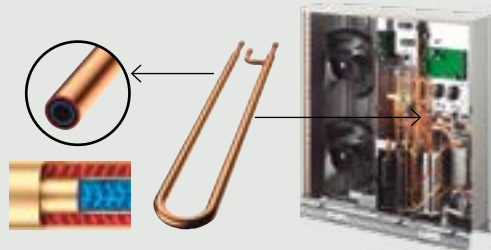

**Aquarea T-CAP Super Quiet**

**Up to 7 dB(A) quieter, same outstanding performance.**

The Super Quiet outdoor units operate up to 7 dB(A) quieter than standard T-CAP models, ensuring peace for residents and neighbours without compromising performance.

Perfect for noise-sensitive environments where outdoor units must blend into the surroundings.

\*Sound pressure calculation for WH-UQZ09KE8, free standing, A +7 °C, W 35 °C in Quiet mode 3.

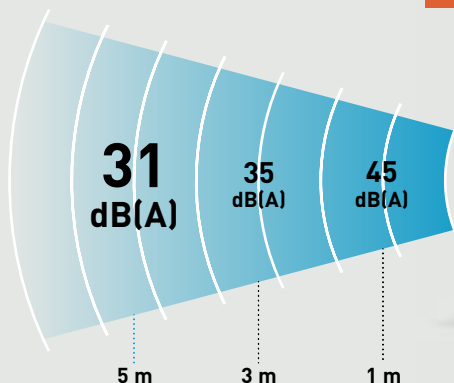

# Aquarea Loop: Efficient radiator retrofit for centralised heating with integrated cooling

The Aquarea Loop is a decentralised water-to-air heat pump using natural refrigerant R290, designed to replace radiators in centralised heating systems.



## Aquarea Home App

### Download free app.

Other hardware requirements: Router and Internet (purchase and subscribe separately). Panasonic Cloud Server is designed, operated and managed by Panasonic.

\*The app screen is for illustration purposes only. The actual screen may differ.



Aquarea Home



Download on the App Store



GET IT ON Google Play



**Ideal for multi-family buildings, social housing, hotels, schools, offices, ...**

**Efficiently replaces existing radiators in centralised heating systems.**

It delivers heating and cooling for buildings with a central water loop 20 ~ 30 °C, ensuring high-efficiency and seamless integration with existing pipework.

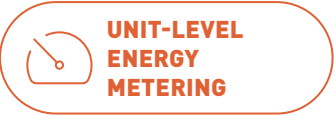

\*Based on the low flow rate requirement – must be checked on each project.

**Additional benefits of the Aquarea Loop:**

- Minimal disruption to the building and option for phased renovation
- Pre-installed hydraulic parts for faster installation
- Compact unit – only 140 mm deep
- No need for gas connection or chimney
- Reduced operating costs for long-term savings
- Full room-by-room autonomy for optimal comfort
- Independent or grouped scheduling via the Aquarea Home app or BMS
- High seasonal efficiency across the entire system
- Lower CO<sub>2</sub> emissions compared to traditional heating systems

**Flexible heating and cooling for collective buildings.**

Aquarea Loop is a decentralised solution for heating and cooling connected to a central water loop. Operating at low water temperatures (20 ~ 30 °C), it prevents condensation, reduces energy losses and optimises system efficiency.

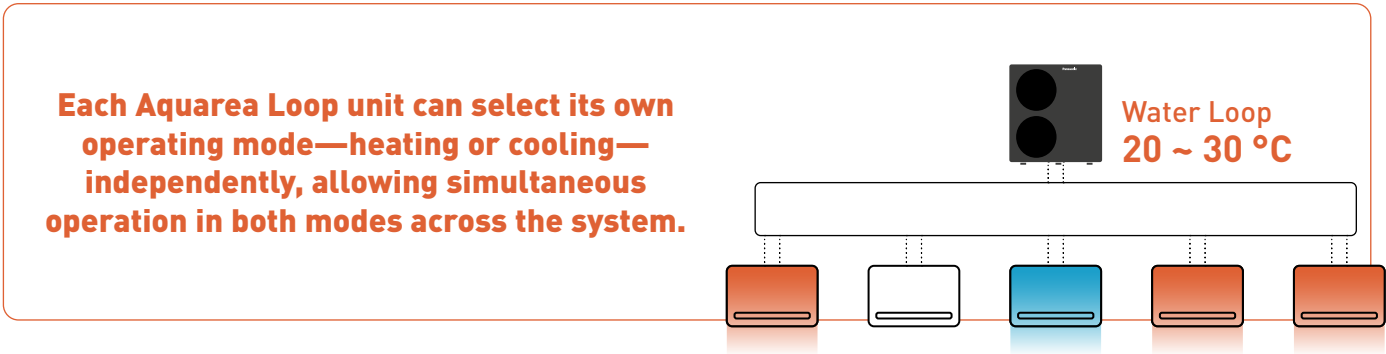

**Retrofit application: centralised low temperature installation for decentralised heating and cooling.**

- 1 Centralised Aquarea Heat Pump (first stage of generation) replacing a high temperature traditional heat source
- 2 Loop water temperature 20 ~ 30 °C. The existing pipework may be reused
- 3 Aquarea Loop heat pump (second stage of generation) replacing conventional radiators

Water Loop 20 ~ 30 °C

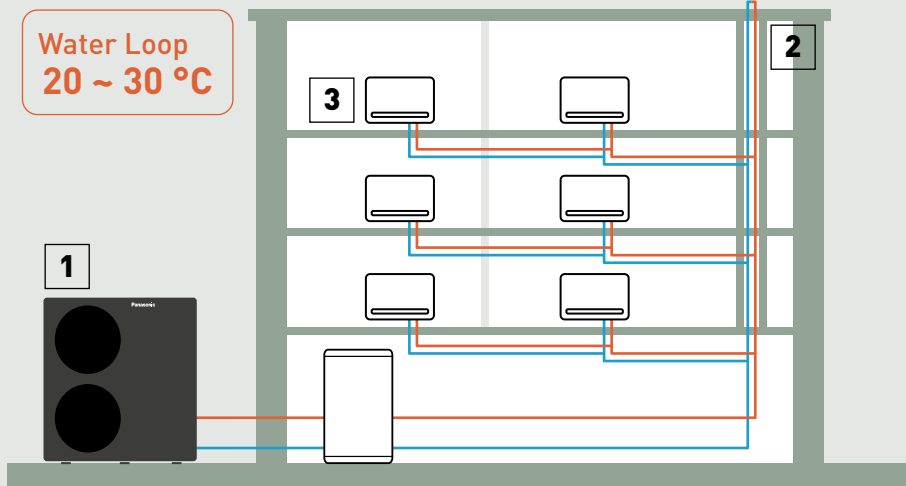

## New Aquarea EcoFlex

**2-in-1 – Flexible comfort and efficiency all year round.**

The new Aquarea EcoFlex offers enhanced versatility. It delivers heat recovery hot water, heating, cooling, and cleaner air with nanoe™ X technology, all in one compact solution.

R32  
REFRIGERANT



**Comfort, flexibility and energy savings in one compact solution.**

EcoFleX delivers heating, cooling and hot water from a single system. Its advanced heat recovery technology reuses energy to maximise savings while ensuring continuous comfort.

**MAXIMUM FLEXIBILITY**

**ULTIMATE COMFORT**

**FURTHER ENERGY SAVINGS**

**COMPACT DESIGN**

Up to 3 air to air indoor units plus an air-to-water unit with an integrated DHW tank.

Continuous heating, cooling, DHW and cleaner air with nanoe™ X, down to -25 °C.\*

\*For CU-4WZ90CBE5, CU-2WZ71YBE5 operates down to -15 °C.

Heat recovery during cooling provides free DHW, reducing energy costs.

The compact outdoor unit delivers both heating or cooling and DHW simultaneously.

**EcoFleX system overview**

1 outdoor unit. Up to 3 air to air indoor units for space heating or cooling. 1 air to water indoor unit for DHW and heating via radiators or underfloor heating.

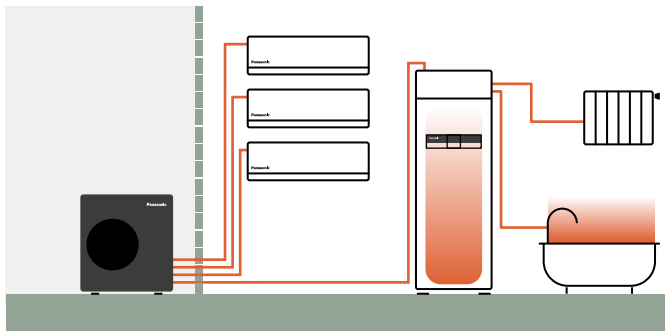

**Wide choice of indoor units for any installation**

A versatile range of indoor units, including Etherea wall-mounted and EcoFleX ducted units, both featuring nanoe™ X technology, plus slim duct options for narrow ceilings. The ideal solution for any project.



**Unique technologies behind Aquarea EcoFleX**

**Heat recovery.**

During cooling, the heat extracted from indoor air is recovered and used to produce domestic hot water, maximising energy efficiency.

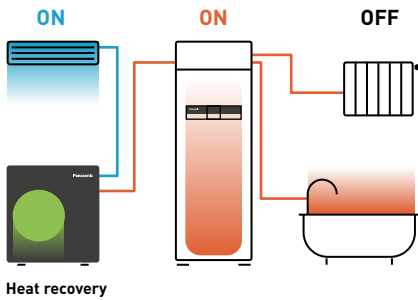

**Bi-heating.**

Simultaneous operation for space heating (air to air), heating via radiators or underfloor systems, and domestic hot water.

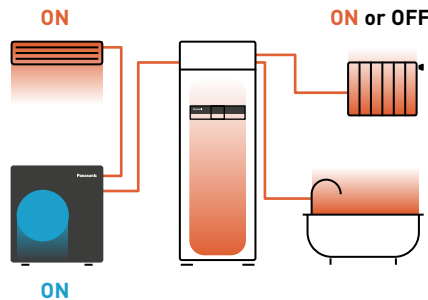

**Non-stop heating.**

During defrost cycles, heat from the tank maintains air to air heating, ensuring continuous comfort without interruptions.

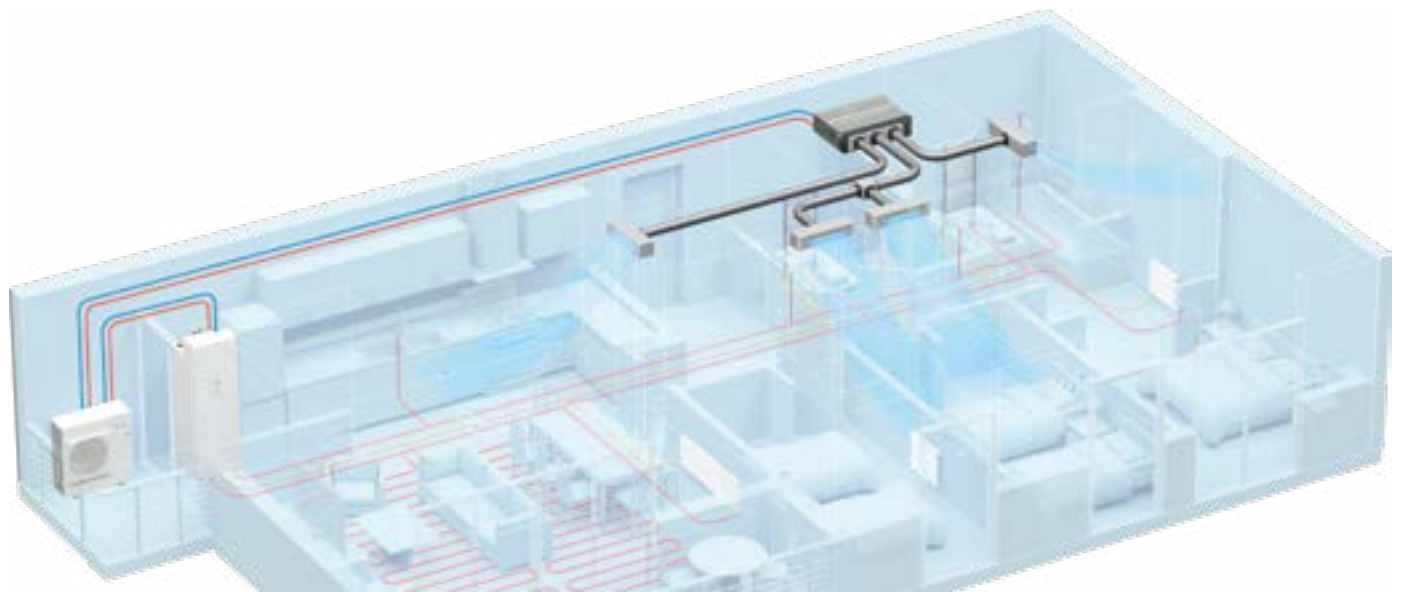
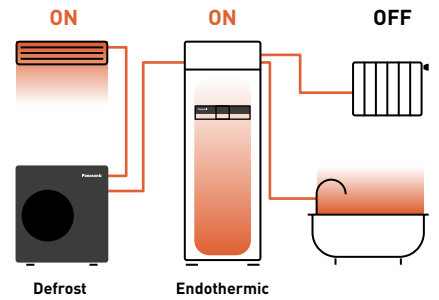

# Aquarea EcoFlex. Air to water indoor unit

Integrated DHW tank and heat exchanger for domestic hot water and space heating via radiators or underfloor systems.

## Compact design for easy integration.

Ideal for kitchens, utility rooms or confined spaces, with a depth comparable to standard kitchen appliances for seamless installation.



NEW

## Compact, yet easy to maintain.



Adapted door opening mechanism.

### Easy service access.

Front access to hydraulic components via door mechanism reduces maintenance time and cost.

### High-efficiency water filter.

Superior filtration minimises tank maintenance for long-term reliability.

**An optional version with a built-in impressed current anode is available for installations in areas with harsh water conditions.**



### Optimised heat exchanger design.

Top-mounted heat exchanger simplifies installation.

### Slim unit with large tank capacity.

185 L tank in a compact footprint (W 599 x D 602 mm) for space-saving installation.

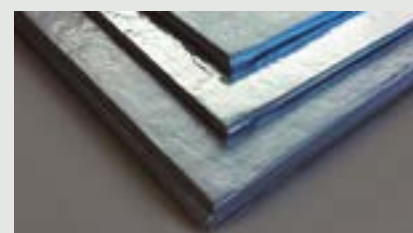

### Advanced U-Vacua™ insulation technology.









High performance vacuum insulation retains heat up to 19 times better than standard urethane foam.

# Aquarea EcoFlex. Air to air indoor units

Connect up to three indoor units for flexible heating and cooling in any space.

## Wide choice of indoor units for any installation.

A versatile range of indoor units, including Etherea wall-mounted and EcoFlex ducted units, both featuring nanoe™ X technology, plus slim duct options for narrow ceilings. The ideal solution for any project.

	Cooling capacity	Indoor unit dimension	Indoor air quality	Comfort	Installation	Connectivity
<b>Aquarea EcoFlex hide-away</b> 	7,1 kW	<b>250</b> x 1000 x 730	 nanoe X Generator Mark 2	 <b>26 dB(A)</b>	Selectable air inlet position Built-in drain pump Static pressure: 10 - 150 Pa	<b>CONEX with Wi-Fi</b> Optional KNX, Modbus, BACnet
<b>Low static pressure hide-away</b> 	2,0 to 6,0 kW	<b>200</b> x 750 x 640	Air filter	 <b>26 dB(A)</b>	Selectable air inlet position Built-in drain pump	Optional KNX, Modbus, BACnet
<b>Wall-mounted Etherea</b> 	1,6 to 7,1 kW	295 x <b>870</b> x 229 (295x1040x244 wide model)	 nanoe X Generator Mark 3 Internal cleaning function	Aerowings 2.0  <b>21 dB(A)</b>	Easy installation	<b>Built-in Wi-Fi</b> Optional KNX, Modbus, BACnet

### nanoe™ X: improving protection 24/7

Acts to clean your air, so that the indoor environment can be a cleaner and more pleasant place to be all day long. nanoe™ X works together with heating or cooling function when you are at home and can work independently when you are away.



**CLEANS THE AIR WHEN YOU ARE AWAY.**  
 LEAVE THE nanoe™ MODE ON TO INHIBIT CERTAIN POLLUTANTS AND DEODORISE BEFORE YOU RETURN HOME

**IMPROVES YOUR ENVIRONMENT WHEN YOU ARE AT HOME.**  
 ENJOY A CLEANER, COMFORTABLE SPACE WITH LOVED ONES

\*Available with Etherea and Ecoflex hide-away indoor units.



## Panasonic Comfort Cloud App

Download free app.

Other hardware requirements: Wi-Fi internet connection (not included) and Smartphone or tablet with internet access. The Panasonic Cloud Server is fully managed and operated by Panasonic.

\*The app screen is for illustration purposes only. The actual screen may differ.

\*Optional Wi-Fi adapter (CZ-TAW1B/CZ-TAW1C) is required.



Comfort Cloud





# Smart Solutions for Aquarea systems

Panasonic provides a comprehensive range of smart solutions for managing heating, cooling, and domestic hot water installations with Aquarea Heat Pumps.

Each app features advanced functionality, user-friendly interfaces, and seamless connectivity, providing complete control and optimization of Aquarea systems.



With multiple apps designed to meet a variety of requirements, the optimal solution can be chosen based on the specific needs of the project—whether it’s achieving greater energy savings, enhancing comfort, or ensuring peace of mind with remote maintenance by a service partner.

Compare Aquarea Smart Solutions	 Comfort Cloud	 Aquarea Home	
	Panasonic Comfort Cloud App	Aquarea Home App	tado°
<b>Aquarea Heat Pump management</b>	✓ Requires Cloud adapter CZ-TAW1B. Included with Aquarea L, M Series and EcoFlex.	✓ Requires Home Network Hub PCZ-ESW737.	✓ Requires Heat Pump Optimizer X PAW-THPOXE.
<b>Remote maintenance via Aquarea Service Cloud</b>	✓	—	—
<b>Room control</b>	✓ 1 or 2 heating zones control	✓ Aquarea Air Smart fan coils Aquarea Loop Aquarea Vent RAC Solo Requires remote control with Wi-Fi or Home Network Hub PCZ-ESW737.	✓ Radiators Underfloor heating Requires tado° Room control devices and Heat Pump Optimizer X or Bridge X.

# Aquarea Home App, seamless control of all Aquarea room solutions



Aquarea Home

**Introducing the Aquarea Home App: Effortlessly manage the Aquarea room solutions anytime, anywhere, 24/7.**

**Integrated control of Aquarea Heat Pumps and room solutions through a single intuitive, user-friendly app <sup>1)</sup>.**

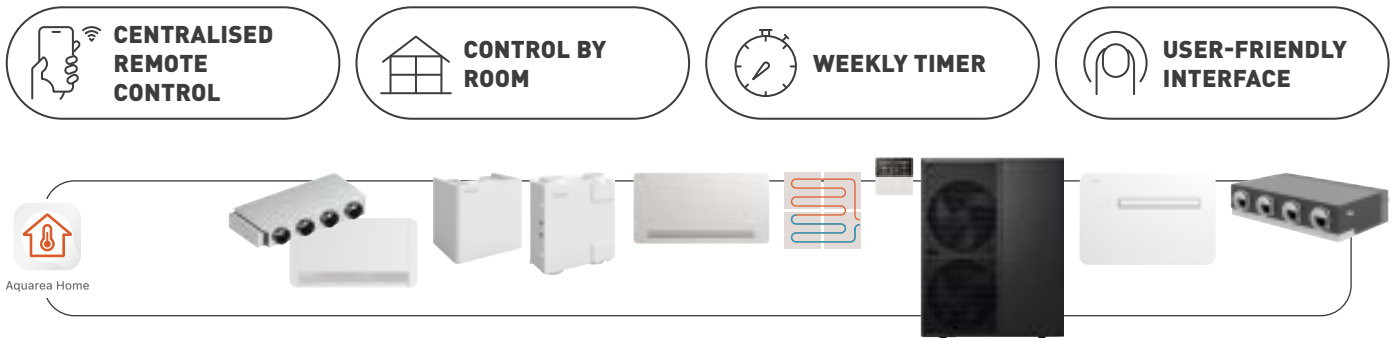

1) Aquarea Air Smart fan coils, Aquarea Vent, Aquarea Loop, underfloor heating (field supply), RAC Solo and PACi NX multi zone duct: requires a remote control with Wi-Fi connectivity or a Modbus controller connected to the Aquarea Home Network Hub (PCZ-ESW737). 2) Aquarea Heat Pumps: require the Home Network Hub (PCZ-ESW737) to be connected to the CN-CNT port.

**Comfort management, anytime, anywhere.**

**Home and room management.**  
Control heat pumps and terminals by room; monitor indoor/outdoor temperatures.

**Device settings.**  
Adjust ON / OFF, temperature, and operating mode for all devices.

**Scheduling.**  
Set independent weekly timers for each device.

\*The app screen is for illustration purposes only. The actual screen may differ.

## Connecting to Aquarea Home.

Aquarea Home supports two connection methods:

- Direct Wi-Fi connection
- Connection via the Home Network Hub (PCZ-ESW737): One heat pump and up to 16 room solutions per Hub

Both methods can be used simultaneously within the same home or installation.

## Requirements for connecting with Aquarea Home App

### 1 | Compatible devices and required accessories

	Connection via Wi-Fi	Connection via Home Network Hub (PCZ-ESW737)
<b>Aquarea Air Smart fan coils</b>	☐ Requires PCZ-EFB749 or Wi-Fi on-board display	☐ Requires PCZ-EEB749 or Modbus on-board display
<b>Aquarea Loop</b>	☐ Requires Wi-Fi on-board display	☐ Requires Modbus on-board display
<b>Aquarea Vent</b>	☐ Requires PCZ-AHRP0025	☐ Requires PCZ-AHRP0026
<b>Underfloor heating (field supply)</b>	☐ Requires PCZ-EG1028 and PCZ-EFB749	☐ Requires PCZ-EG1028 and PCZ-EEB749
<b>Aquarea H Series onwards</b>	—	☐ Connection to CN-CNT port
<b>RAC Solo</b>	☐	☐
<b>PACi NX multi zone duct</b>	☐	—

- 2 | In-house WLAN or Wi-Fi internet connection
- 3 | Smartphone or tablet with internet connection

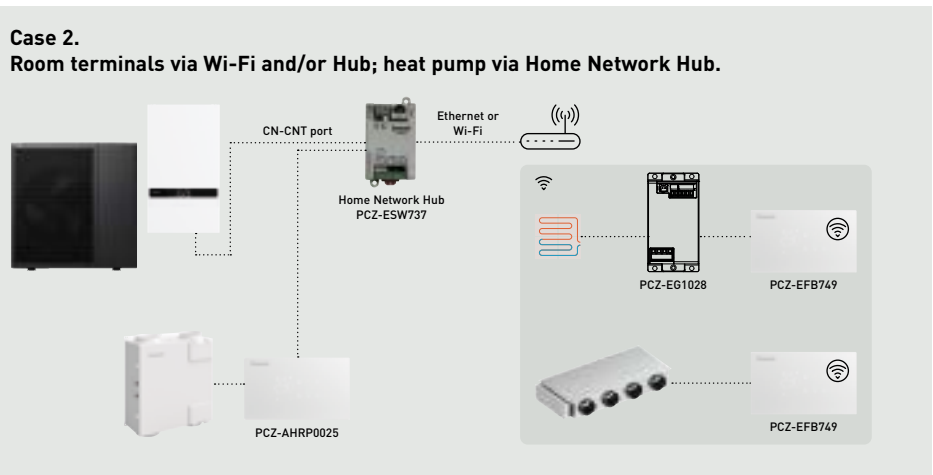
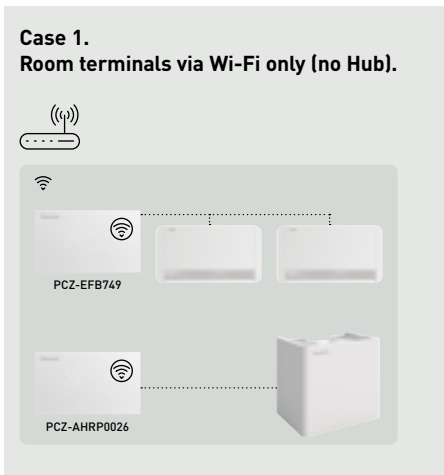

# Panasonic Comfort Cloud App

A powerful and intuitive app designed to manage and monitor your Panasonic heat pumps from anywhere, 24/7. With energy monitoring features, it helps reduce operational costs while ensuring your desired comfort.



Comfort Cloud

\*Requires Wi-Fi adapter CZ-TAW1B or CZ-TAW1C.



## Comfort management, anytime, anywhere.

Easily control heating, cooling, and DHW settings through an intuitive interface, maximising energy savings and comfort.

- Control of up to 2 heating zones (ON / OFF, temperature setting, mode selection, DHW setting)
- Optimised scheduling with weekly timer



## Easy and powerful energy management.

Monitor and optimise your heat pump's energy usage to balance comfort and efficiency.

- Track energy consumption for space heating, cooling and domestic hot water
- Daily, weekly and yearly energy visualisation monitor energy recovery for domestic hot water production with Aquarea EcoFlex



## Further peace of mind

Ensure your Aquarea Heat Pump is always under control.

- Enables remote maintenance via the Aquarea Service Cloud, managed by service partners
- Notification in case of malfunction

## Requirements for connecting with Panasonic Comfort Cloud App

- 1 | Aquarea H Series or later
- 2 | Cloud adapter, CZ-TAW1B or CZ-TAW1C connected via the CN-CNT port. Included in M and L Series, and EcoFlex. For other series, it needs to be purchased separately.
- 3 | In-house WLAN or Wi-Fi internet connection
- 4 | Smartphone or tablet with internet connection

## Panasonic Comfort Cloud App

Download free app.

Other hardware requirements: Wi-Fi internet connection (not included) and Smartphone or tablet with internet access. The Panasonic Cloud Server is fully managed and operated by Panasonic.  
\*The app screen is for illustration purposes only. The actual screen may differ.  
\*Optional Wi-Fi adapter (CZ-TAW1B/CZ-TAW1C) is required.



Comfort Cloud





# Aquarea Service Cloud

With the Aquarea Service Cloud, installers can remotely take care of their customers' heating systems. It saves time and money and shortens the response time, thus increasing the customers' satisfaction.

# AQUAREA Service Cloud

 **TIME AND COST SAVING. REMOTE SYSTEM ADJUSTMENT. REMOTE DIAGNOSIS. ONE VISIT, SPARE PART IN HAND**

 **INCREASED CUSTOMER SATISFACTION. FASTER SERVICE. TIME SAVING (LESS NUMBER OF VISITS)**



**Home page.**  
Overview of connected users at a glance with two display options: map view or list view.



**Unit status.**  
Real-time overview of the unit's operating status with up to 28 key parameters.



**Statistics.**  
Customisable performance statistics covering up to 71 parameters, accessible anytime for detailed analysis.



**Unit settings.**  
Remote configuration of most user and installer settings for convenient system management.

Note: User interface design may vary.

Aquarea Service Cloud offers three versions to optimise system performance and reduce downtime.

Aquarea Service Cloud	Standard version. Remote maintenance made simple	Advanced version. For preventive and corrective maintenance	Diagnosis version. For predictive maintenance
License pack (20 licenses)	—	SR-A2W-SVCADV20	SR-A2W-SVCDIA20
RRP (20 licenses)	Free of charge	Check price	Check price
Unit status	✓	✓	✓
Unit settings	✓	✓	✓
Error logs	Last 4	Last 50	Last 50
Statistics	7 days	1 year	1 year
Statistics bulk download		✓	✓
Group management		✓	✓
System diagram		✓	✓
Pre-error data*		✓	✓
24h diagnosis algorithms			✓
COP weekly average			✓

**Requirements:**

- 1 | End user: Aquarea Heat Pump connected to the Panasonic Comfort Cloud App
- 2 | Installer/maintenance company: Service ID. Installer registration: <https://aquarea-service.panasonic.com/>

**Activation in just 3 steps**

- 1 | Log in to Panasonic Comfort Cloud App (end user) or Aquarea Service Cloud (installer)
- 2 | Submit the activation request. The process can be initiated by either party
- 3 | Confirmation is completed via email link by the other party

\*The end user can adjust the installer's level of control at any time (four levels).

# Aquarea Heat Pumps + tado°, the integrated solution for maximum energy savings and comfort

tado° X enables room control and smart energy management services.



tado° smart heating customers save an average of 22% on their energy consumption.

\*Based on internal data averaged across all tado° customers, collected up to 11/2023.

## A smart solution for maintaining the perfect temperature in your home.



**1**  
**tado° Heat Pump Optimizer X.**  
Connecting to Aquarea Heat Pumps and enabling multi-room control and loadshifting.



**tado° app and Balance for Heat Pumps\*.**  
Multi-Room Control, scheduling and energy insights in one market leading app.  
\*Requires additional subscription.

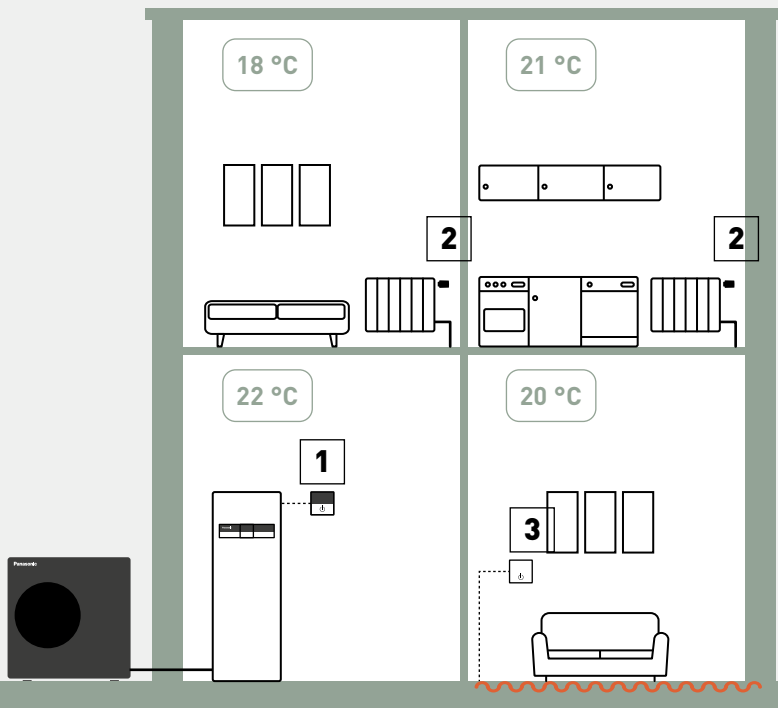

**2**  
**tado° Smart Radiator Thermostat X.**  
For radiator control.



**3**  
**tado° Wired Smart Thermostat X.**  
For underfloor heating control.

**Panasonic and tado° are redefining comfort and energy savings for Aquarea Heat Pumps.**

With joint developments such as **AQUAREA Sync**, which boosts efficiency by up to 10%, and **Hydronic Balancing** for optimal heat distribution, homeowners enjoy smarter control and greater energy savings.

Partnership for smart heat pump solutions

**MORE tado° OPTIONS IN ACCESSORIES SECTION**

**EASY INSTALLATION**

Intuitive system selection. Offline installation possible.

**FUTURE-PROOF SOLUTION**

Further efficiency gains via planned software updates.

**ADVANCED ENERGY SAVINGS**

With the individual room temperature control.

**RELIABLE AND TRUSTWORTHY**

Guaranteed and optimised interoperability.



**tado° Heat Pump Optimizer X and Balance for Heat Pumps.**

Intelligent heating control optimised for Aquarea Heat Pumps. The optional Balance subscription maximizes savings by unlocking additional optimisations.



**tado° Room Control.**

tado° Smart Thermostats simply replace the radiator thermostats or wall thermostats in your home and let you control your heating room by room in one easy-to-use app.

1) Requires the tado° Heat Pump Optimizer X, the tado° Bridge X or another Thread border router. 2) Not required with a Heat Pump Optimizer X or another Thread border router.

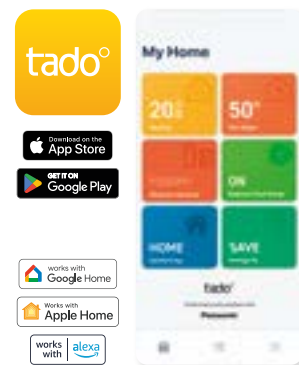

**The tado° app.**

Intuitive smart heating technology with Geofencing, Open Window Detection, Multi-Room Control, and offline Smart Schedules.

**Exclusive benefits with the Panasonic | tado° bundle.**

**12 MONTHS FREE BALANCE FOR HEAT PUMPS**

**AQUAREA SYNC FOR UP TO +10% HIGHER EFFICIENCY**

**HYDRONIC BALANCING INCLUDED\***

\*Normally only available with AI Assist subscription.



**Hydronic Balancing.**

tado° Room control sets with Heat Pump Optimizer X	
<b>KIT-TSRTXHPOXE</b>	Set of tado° Heat Pump Optimizer X and 1x Smart Radiator Thermostat X
<b>KIT-TSRTX4HPOXE</b>	Set of tado° Heat Pump Optimizer X and 4x tado° Smart Radiator Thermostat X
<b>KIT-TSTXHPOXE</b>	Set of tado° Heat Pump Optimizer X and 1x Smart Thermostat X
<b>KIT-TSTXSRTX2HPOXE</b>	Set of tado° Heat Pump Optimizer X and 1x Smart Thermostat X and 2x Smart Radiator Thermostat X

tado° Room control sets with Bridge X	
<b>PAW-TSRTXB</b>	tado° Smart Radiator Thermostat X with Bridge X
<b>PAW-TSTXB</b>	tado° Smart Thermostat X with Bridge X
<b>PAW-TSTXSRTX2B</b>	Set of 1x Smart Thermostat X, 2x Smart Radiator Thermostat X and 1x Bridge X
tado° X devices	
<b>PAW-THPOXE</b>	tado° Heat Pump Optimizer X (with Europlug)
<b>PAW-TSTX</b>	tado° Smart Thermostat X
<b>PAW-TSRTX</b>	tado° Smart Radiator Thermostat X
<b>PAW-TSRTX4</b>	4x tado° Smart Radiator Thermostat X
<b>PAW-TWTSX</b>	tado° Wireless Temperature Sensor X
<b>PAW-TBX</b>	tado° Bridge X
<b>PAW-TWRXE</b>	tado° X Wireless receiver

# Control and connectivity

**Aquarea Heat Pumps provide a range of control options for efficient system management.**

Integration with KNX and Modbus enables centralised operation through home management systems, optimising performance and costs.

## Advanced remote controller.

**Aquarea remote controller is designed in harmony with the whole system, with optimised user interface and improved features.**

The remote controller can be removed from the indoor unit and installed in the living room.

## K, L and M Series remote controller.

Dual controller system: A dual controller system for independent control of two zones within the home (requires additional remote controller CZ-RTW2-1 for M Series or CZ-RTW1 for K and L Series).



	K, L and M Series				H and J Series	
	Main controller		Sub controller		Main controller	
Quick menu	✓		✓		✓	
User menu	✓		✓		✓	
Installer / custom menu	✓		—		✓	
Maintenance menu	✓		—		✓	
Error reset	✓		✓		✓	
Internal thermostat	✓ Zone 1	✓ Zone 2	✓ Zone 1	✓ Zone 2	✓ Zone 1	✓ Zone 2

### Installer functions:

System setup, operation setup (including heating / cooling modes,  $\Delta T$  setup), dry concrete mode and cost-effective bivalent mode\*, among others.

\*Only for K, L and M Series.

### End user functions:

Mode selection (including auto, powerful and quiet modes), weekly timer and energy monitoring, among others.

## PCBs for additional functions.

**CZ-NS4P: H and J Series.**

**CZ-NS5P: K and L Series.**

**CZ-NS6P: M Series All in One and Bi-bloc.**

**CZ-NS7P: M Series control module.**

The optional PCB enables additional control functions for Aquarea Heat Pumps.

Functions available through the connection of the Optional PCB to the Main PCB:

- 2-zone control, with 2 mixing valves, 2 pumps and 2 room thermostats or sensors
- Control of swimming pool
- Solar thermal control
- External error signal output
- 0-10 V signal for heat pump demand control
- SG Ready <sup>1)</sup>
- Stop compressor by external compressor switch
- Switch heating and cooling by external heat-cool switch

<sup>1)</sup> Aquarea H and J Series heat pumps in combination with the optional PCB CZ-NSP4 hold the SG Ready Label (Smart Grid Ready Label), given by Bundesverband Wärmepumpe (German Heat Pump Association). This Label shows the real capacity of Aquarea to be connected in an intelligent grid control.









## Control by BMS.

Maximum flexibility for seamless integration with KNX and Modbus projects, enabling full bi-directional monitoring and control of all operating parameters.

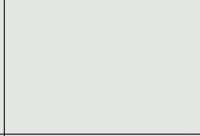
- Quick and easy installation
- Direct connection to the unit via the CN-CNT connector
- Bidirectional control
- Simultaneous operation via remote controller and gateway

\*For specific functionality list of each gateway, please check the user's manual.

	Modbus RTU gateways			
				
	<b>PAW-AZAW-MBS-M</b>	<b>PAW-AW-MBS-M</b>	<b>CZ-NSMB-C</b>	<b>CZ-NSMB</b>
Dimension (H x W x D)	80 x 92 x 22 mm	93 x 53 x 59 mm	93 x 53 x 25 mm	85 x 50 x 20 mm
Mounting	Fixed by 2 screws or double-sided adhesive	DIN Rail	DIN Rail	Inside Big Aquarea T-CAP, Control Module, Bi-bloc and All in One*.
Configuration	App and Bluetooth®	DIP switch	DIP switch	DIP switch
External power supply	12 V DC	Not required	Not required	Not required
Compatibility	H Series onwards	H Series onwards	H Series onwards	M Series

	KNX gateways		EEBus gateways
			
	<b>PAW-AZAW-KNX-1</b>	<b>PAW-AW-KNX-H</b>	<b>PAW-AZAW-EEBUS-1</b>
Dimension (H x W x D)	80 x 92 x 22 mm	59 x 45 x 21 mm	80 x 92 x 22 mm
Mounting	Fixed by 2 screws or double-sided adhesive	Not required	Fixed by 2 screws or double-sided adhesive
Configuration	App and Bluetooth®	DIP switch	App and Bluetooth®
External power supply	12 V DC	Not required	12 V DC
Compatibility	J, K or L Series	H, K or L Series	H Series onwards

\*Big Aquarea T-CAP: WH-WXG20ME8, WH-WXG25ME8 and WH-WXG30ME8. Control module: WH-CME5, WH-CME8 and WH-CME8L. Bi-bloc (requires installation kit CZ-NSMB-MTPL): WH-SDC0916M3E5, WH-SDC0916M6E5 and WH-SDC0316M9E8. All in One (requires installation kit CZ-NSMB-MTPL): WH-ADC0916M3E51, WH-ADC0916M3E52, WH-ADC0916M6E52, WH-ADC0916M3E53, WH-ADC0916M6E53, WH-ADC0316M9E81, WH-ADC0316M9E82, WH-ADC0316M9E83.

## External meter gateway.

### PAW-A2W-EXTMETER

- Energy consumption and production from external Modbus RTU meters
- Real values visualized via Aquarea remote controller and Panasonic Comfort Cloud App
- Compatible with Aquarea K Series onwards



#### Possibility to mix internal calculation and external meters

Configuration	Electricity meter (HP)	Heat meter (heating and cooling)	Heat meter (DHW)
Only external meters	External	External	External
Only external consumption meter	External	Internal calculation	Internal calculation
Only external production meters (2 meters)	Internal calculation	External	External
Only external production meter [single meter for total production]	Internal calculation	External	Internal calculation

#### Functions:

- Configuration via App (iOS and Android™) using Bluetooth®
- Easy to setup thanks to templates for some meters manufacturers
- Configuration can be done before and just send it on commissioning

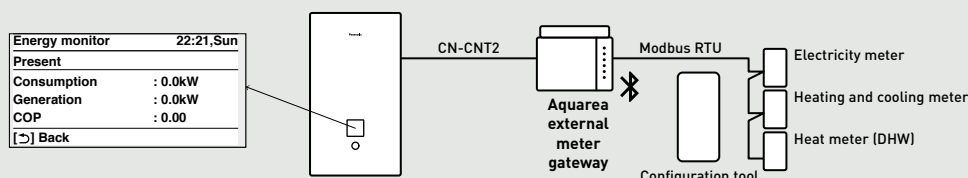

## Cascade manager

Designed for central heating projects, small hotels, supermarkets and restaurants, the cascade manager manages the demand for energy efficient heating and cooling balancing working hours.



### Up to 10 heat pumps (up to 300 kW)

- Cascade up to 10 units
- Heating and cooling control
- Domestic hot water (DHW) control
- Management up to 75 °C (L or M Series)
- Provides total energy consumption and generation
- All components in one case
- BMS integration

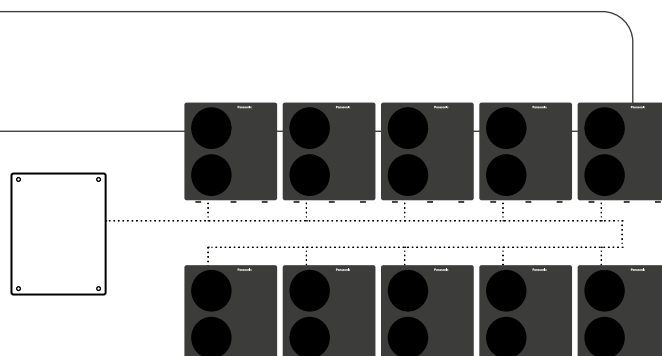

## Cascade manager.

### PAW-A2W-CMH-3

Cascade up to 10 heat pumps, getting up to 300 kW, with a large, easy-to-use touch screen display, providing intuitive control.

- Photovoltaics integration (PV optimised algorithm)
- Control of 3 way valves for cooling (2 buffer tanks)
- Heating/cooling 0-10 V demand signal – controls target outlet temperature
- Energy meters compatibility
  - Meters communication with Modbus RTU
  - Pre-configuration of 4 market popular meters
- BMS integration via Modbus TCP
- Working mode: entire system in heating/cooling or DHW by priority



### Compatible with Aquarea Heat Pumps from H Series onwards <sup>1)</sup>.

<sup>1)</sup> Requires 1 CZ-NSMB or 1 PAW-AZAW-MBS-M per each Aquarea Heat Pump.

## Aquarea Cascade Edge.

### PAW-A2W-CME4 and PAW-A2W-CME10

Cascade up to 4 or 10 Aquarea Heat Pumps, also in combination with ECOi-W AQUA chillers and heat pumps, and get up to 750 kW <sup>1)</sup>. Remotely control your units with a local web visualization via smartphone, tablet or PC.

- Local web visualization of the cascade controller
- Easy connection with smartphone, tablet or PC thanks to the Wi-Fi access point on the device
- 2 possible online management solutions:
  - P-Smart Nexus: easy access and global visualization of all your sites
  - Via customer VPN or MyDNS configuration
- Data ownership thanks to local data storage (no cloud storage)
- BMS Integration via BACnet IP
- Smaller buffer tank or smaller capacity unit thanks to 2 possible logic working modes
  - Possibility to combine all the heat pumps between heating/cooling and DHW, providing both simultaneously
  - Entire system in heating/cooling or DHW by priority
- Configuration wizard with default values



### Compatible with Aquarea Heat Pumps from H Series onwards <sup>2)</sup>.

<sup>1)</sup> Maximum capacity combining 1 Aquarea (main) + 9 ECOi-W AQUA-G BLUE 80 kW (sub unit). <sup>2)</sup> Requires 1 CZ-NSMB or 1 PAW-AZAW-MBS-M per each Aquarea Heat Pump.



**P-Smart Edge.**  
Control and monitoring online solution for Aquarea Cascade Edge systems wherever you are. In a simple click, configure and receive status updates of all your units.



**P-Smart Nexus.**  
Smart multi-site online control which allows a remote global supervision of all your sites.



	PAW-A2W-CMH-3	PAW-A2W-CME4	PAW-A2W-CME10
Cascade up to number of heat pumps	Up to 10	Up to 4	Up to 10
Management of heat demand, balancing working hours	✓	✓	✓
Integration of photovoltaics (PV optimised algorithm)	✓	–	–
Connectable buffer tank	2 tanks	1 tank	1 tank
Heating/cooling 0-10 V demand signal	✓	–	–
BMS integration	Modbus TCP	BACnet IP	BACnet IP
Built-in touch screen display	✓	–	–
Management via smartphone, tablet or PC	–	✓	✓
Remote monitoring via P-Smart Edge	–	✓	✓
Multi-site control via P-Smart Nexus	–	✓	✓
Data statistics visualization	–	✓	✓

## P-Smart Edge for Aquarea Cascade Edge

Complete and remote centralized control of your Aquarea cascade system.



**P-Smart Edge.**

Control and monitoring solution for Aquarea cascade systems wherever you are. In a simple click, configure and receive status updates of all your units.

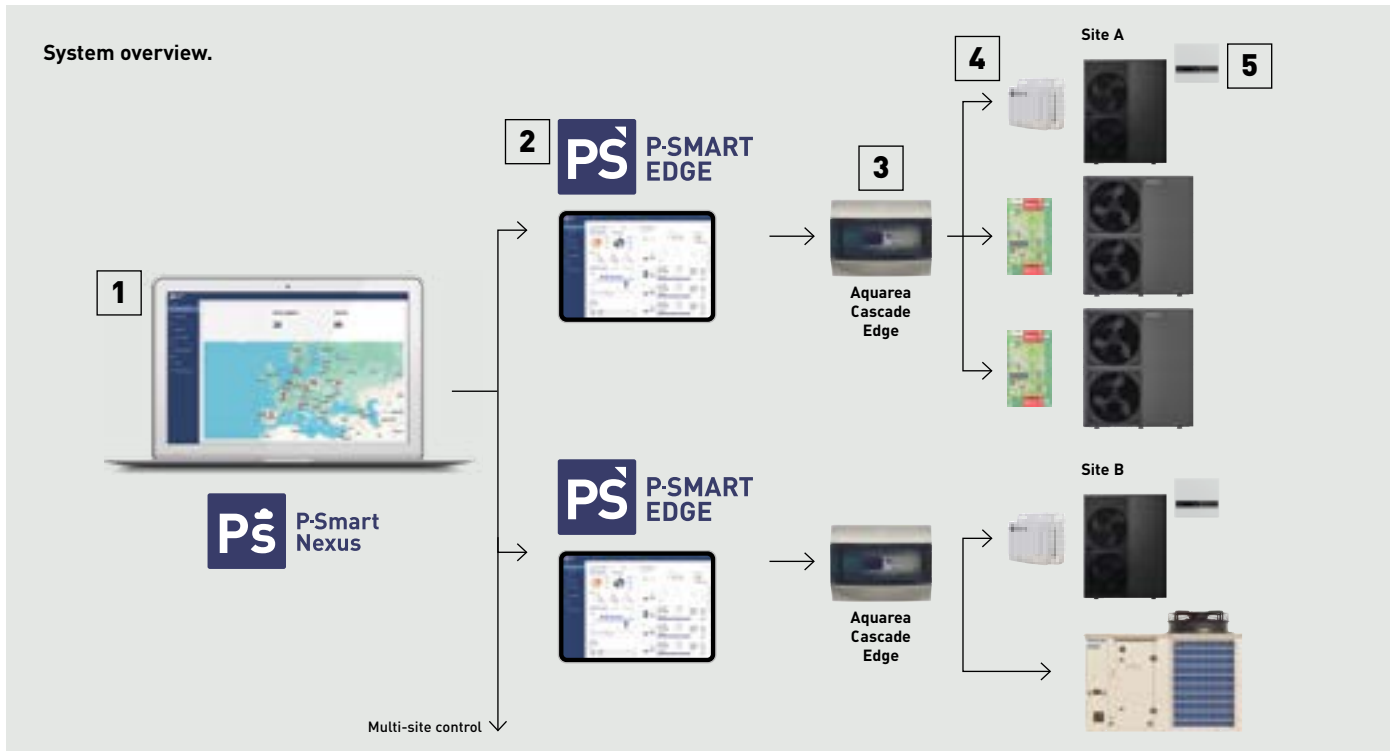

**1 P-Smart Nexus.**  
Smart multi-site control which allows a remote global supervision of all your sites. Control your different installations wherever you are, with easy on-site network setup.

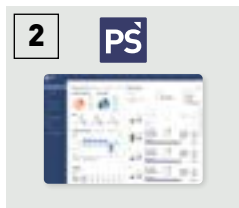

**2 P-Smart Edge.**  
Control and monitoring solution for Aquarea cascade systems, even outside your installation site.



**3 Aquarea Cascade Edge.**  
PAW-A2W-CME4 and PAW-A2W-CME10.



**4 Modbus interface.**  
Requires 1 Modbus gateway (see page 34) per each Aquarea Heat Pump.



**5 Aquarea cascade system.**  
Main unit: control module or Bi-bloc mandatory + optional PCB.  
Sub units: remote controller needed. Possibility of combination with other Panasonic commercial products (ECOi-W AQUA chillers and heat pumps).

\*Check availability for chiller connection.

**Advantages**



**Powerful remote management with user-friendly interface.**

- Simple and intuitive home screen with: Plant overview, energy overview, DHW status and buffer and zone list
- Alarm status and history
- 3 different user profiles: facility manager, installer and maintenance
- Online visualization, no installation of any specific software is required



**Remote configuration of the technical parameters.**

Possible configuration of:

- Installation settings
- Sterilisation configuration [schedule]
- Outdoor units silence mode [schedule]
- Bivalent
- SG Ready
- COP ranking



**Historical system data.**

- Graphs and data showing the energy overview related to periods of 7 days or 8 hours
- Data stored for up to 2 years



**P-Smart Nexus: smart multi-site remote management.**

- Remote global supervision of all your sites in one place
- 24/7 control of all the installations
- Easy connection to Aquarea Cascade Edge without special on-site network setup
- 3-year subscription from the start-up included
- Online visualization, no installation of any specific software is required

Note: User interface design may vary.

# How Panasonic contributes to Nearly Zero Energy Buildings (nZEB)

Our expertise gained over the years has helped to launch a range of products that contribute to a more carbon-free society.

**Panasonic is committed to develop products with greater energy efficiency.**

Highly efficient Panasonic solutions can help to significantly reduce the energy consumption of the house, at the same time a high level of comfort and good indoor air quality are kept.

- Aquarea High performance heat pump for heating, cooling and domestic hot water production
- Panasonic Comfort Cloud App, for energy monitoring
- Heat recovery ventilation system
- PV panels to produce renewable energy on-site



## Aquarea Heat Pumps and the ventilation unit with heat recovery certified as Passive House Component

Aquarea High Performance K and L Series heat pumps and the residential ventilation units have been certified by the Passive House Institute (PHI) as Passive House Component. This certification ensures highly energy efficient components according to international criteria for respective thermal performance, comfort and indoor air quality.

Certified models can be checked under the certification section of <https://database.passivehouse.com>.

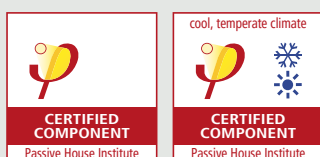

### H3 Grande Passive House, Poland.

When looking for a energy efficient heating solution, Polish construction company Procyon selected a 5 kW Panasonic Aquarea High Performance heat pump for its passive house project, H3 Grande. Procyon found this solution reduced annual heating expenses by almost half compared to an oil-based system, or by 10% in comparison to natural gas.

H3 Grande is a 175 m<sup>2</sup> detached house certified by the Passive House Institute (PHI) in Darmstadt. It is designed to minimise energy losses while incorporating an attractive, yet simple aesthetic. The building's shape, interior design and pitched roof contribute to the energy balance of the house, while large south-facing windows and wall insulation provide passive thermal comfort by retaining heat. The building has very low heating demand of approximately 15 W/m<sup>2</sup> and is designed to minimise energy.

# Aquarea and PV integration

**Aquarea Heat Pumps are designed with the future in mind.**

Thanks to the integration of the Aquarea Heat Pumps with PV, the demand or power consumption for heating, cooling and domestic hot water production is adapted to the PV production.







**SAVINGS ON  
HEAT PUMP  
RUNNING COSTS**



**REDUCED  
PRIMARY ENERGY  
CONSUMPTION**



**CO<sub>2</sub> LOWER CO<sub>2</sub>  
EMISSIONS**



**MAXIMISED  
COMFORT**

## Aquarea Heat Pumps can be integrated with PV thanks to the optional PCB <sup>1)</sup>

With the SG Ready function, the Aquarea Heat Pumps will be able to store thermal energy during periods where the electricity produced is higher than the demand in the house. These are some examples:

- 1** | Store DHW at higher temperature. Aquarea M and L Series can produce DHW at 65 °C up to 40% more tap water
- 2** | Heat or cool the house to maintain a comfortable temperature continuously. This requires less energy during the off-peak production hours
- 3** | Store thermal energy in a buffer tank

1) CZ-NS\*P. Check the model reference by Series in the control for Aquarea Heat Pumps section.

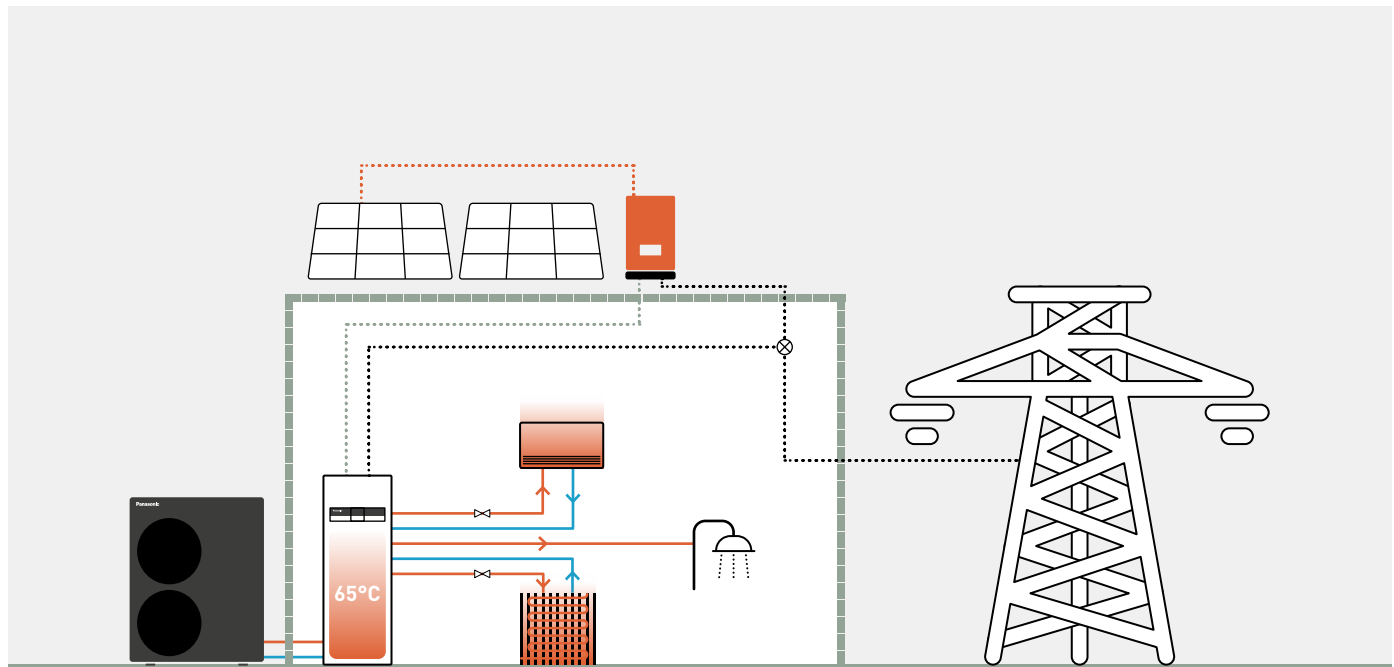

### Turning a family home into an energy-neutral house.

Installer Sinne Technyk chose the Aquarea T-CAP heat pump in combination with HIT KURO photovoltaic panels for a house in Oudemirdum in Friesland, the Netherlands. With this combination, the household enjoys energy-neutral and free heating and hot water, as well as a more comfortable indoor climate. “The aim was to create an energy-neutral house and to reduce gas consumption to zero,” explains Leo van der Molen of Sinne Technyk. “This makes a heat pump an interesting option”. With the comfort of customers and neighbours in mind, a silent Aquarea T-CAP heat pump was chosen, powered by 24 Panasonic HIT KURO solar panels of 325 Wp each.

# Aquarea design tools to make your life easier

Discover the suite of Aquarea design tools crafted to streamline your professional workflow on Aquarea projects.

These resources are designed to make your planning process more efficient and effective.



## Aquarea Designer.

With Panasonic's Aquarea Designer – Online tool, projects can be developed simply and easily. The newly developed air to water design tool is optimised to help HVAC professionals easily identify the most appropriate Aquarea air to water heat pump for a particular application, to calculate the savings compared to other heat sources and to calculate CO<sub>2</sub> emissions very quickly.

**The system can produce a Heat Pump Design Report which includes:**

- Customer and general project information
- Heating system specific data
- Heat pump dimensioning, including information about the chosen Panasonic heat pump
- Calculated energy demand and performance factors
- CO<sub>2</sub> savings by the different energy sources
- Comparison of yearly operational or economic costs (optional)



All the support tools are available in Panasonic PRO Club ([www.panasonicproclub.com](http://www.panasonicproclub.com)).

Among many others, these are the main tools for the design of Aquarea projects.

PRO Club 



### Hydraulic scheme generator.

The Aquarea Hydraulic Scheme Generator (HSG) allows users to select a hydraulic schematic according to their installation requirements. This will be accompanied by the relevant electrical connection schematic and component list.

**The latest features and upgrades include:**

- A modern user interface
- Accessory model choice selection
- Expanded buffer tank options
- Additional refrigerant and hydraulic specification details

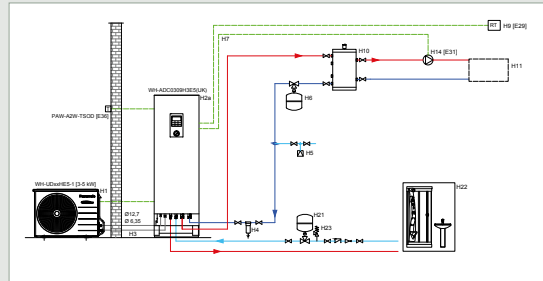

### Vent PRO.

From selecting the right ventilation unit to planning the air distribution system and choosing the appropriate components, the Vent PRO guides you through every step to ensure the optimal solution for your project.



### Heating demand calculator.

This software can quickly and easily determine the heating requirements for the rooms in a project. The Heating demand calculator will help determine approximately how much power is needed to heat each room individually. The result in kilowatts will help you choose the space heater best suited to your needs.

### CAD images and spec texts.

In order to add value in the design of projects, Panasonic has a wide library of 2D CAD, BIM objects (Building Information Modeling) and Spec texts to be used in Revit.























### Try the new Panasonic Augmented Reality projector.



Helping you to find the Aquarea Heat Pumps for your home in just a few clicks!

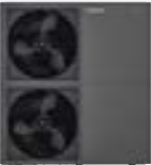
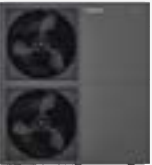
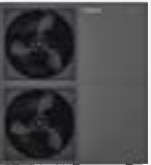

# Aquarea Hydraulic

Aquarea T-CAP	9 kW	12 kW	16 kW	20 kW	25 kW	30 kW
<b>P. 47 , 49</b>   <b>All in One · R290 1ph - 3ph</b>						
	WH-ADC0916M3E51 WH-ADC0916M3E52 <sup>1)</sup> WH-ADC0916M3E5AN2 WH-ADC0916M3E53 <sup>1)</sup> WH-ADC0916M3E5AN3 WH-ADC0316M9E81 WH-ADC0316M9E82 WH-ADC0316M9E8AN2 WH-ADC0316M9E83 WH-ADC0316M9E8AN3 WH-WXG09ME5 WH-WXG09ME8	WH-ADC0916M3E51 WH-ADC0916M3E52 <sup>1)</sup> WH-ADC0916M3E5AN2 WH-ADC0916M3E53 <sup>1)</sup> WH-ADC0916M3E5AN3 WH-ADC0316M9E81 WH-ADC0316M9E82 WH-ADC0316M9E8AN2 WH-ADC0316M9E83 WH-ADC0316M9E8AN3 WH-WXG12ME5 WH-WXG12ME8	WH-ADC0316M9E81 WH-ADC0316M9E82 WH-ADC0316M9E8AN2 WH-ADC0316M9E83 WH-ADC0316M9E8AN3 WH-WXG12ME5 WH-WXG12ME8			
<b>P. 47 , 49</b>   <b>Bi-bloc · R290 1ph - 3ph</b>						
	WH-SDC0916M3E5 <sup>1)</sup> WH-SDC0316M9E8 WH-WXG09ME5 WH-WXG09ME8	WH-SDC0916M3E5 <sup>1)</sup> WH-SDC0316M9E8 WH-WXG12ME5 WH-WXG12ME8	WH-SDC0316M9E8 WH-WXG16ME8			
<b>P. 47 , 49</b>   <b>Control module · R290 1ph - 3ph</b>						
	WH-CME5 WH-CME8 WH-WXG09ME5 WH-WXG09ME8	WH-CME5 WH-CME8 WH-WXG12ME5 WH-WXG12ME8	WH-CME8 WH-WXG16ME8	WH-CME8L WH-WXG20ME8	WH-CME8L WH-WXG25ME8	WH-CME8L WH-WXG30ME8
<b>P. 47 , 49</b>   <b>Stand-alone · R290 <sup>2)</sup> 1ph - 3ph</b>						
	WH-WXG09ME5 WH-WXG09ME8	WH-WXG12ME5 WH-WXG12ME8	WH-WXG16ME8	WH-WXG20ME8	WH-WXG25ME8	WH-WXG30ME8
<b>P. 51</b>  <b>Mono-bloc · R32 1ph - 3ph</b>						
	WH-MXC09J3E5-1 WH-MXC09J3E8-1	WH-MXC12J6E5-1 WH-MXC12J9E8-1	WH-MXC16J9E8-1			

Models with R290 refrigerant. Models with R32 refrigerant.

1) Also available with other backup heater capacities. 2) Requires CZ-RTW2TAW1C.  
 WH-\_\_E5 1ph // WH-\_\_E8 3ph.

Aquarea High Performance		5 kW	7 kW	9 kW	12 kW	16 kW
P. 53 , 55	 <b>All in One - R290</b> 1ph - 3ph	 WH-ADC0509L3E51 WH-ADC0509L3E5 1) WH-ADC0509L3E5B WH-ADC0509L3E5AN 1) WH-WDG05LE5	 WH-ADC0509L3E51 WH-ADC0509L3E5 1) WH-ADC0509L3E5B WH-ADC0509L3E5AN 1) WH-WDG07LE5	 WH-ADC0509L3E51 WH-ADC0509L3E5 1) WH-ADC0509L3E5B WH-ADC0509L3E5AN 1) WH-WDG09LE5  WH-ADC0316M9E81 WH-ADC0316M9E82 WH-ADC0316M9E8AN2 WH-ADC0316M9E83 WH-ADC0316M9E8AN3 <b>NEW!</b> WH-WDG09ME8	 WH-ADC0916M3E51 WH-ADC0916M3E52 1) WH-ADC0916M3E5AN2 WH-ADC0916M3E53 1) WH-ADC0916M3E5AN3 WH-ADC0316M9E81 WH-ADC0316M9E82 WH-ADC0316M9E8AN2 WH-ADC0316M9E83 WH-ADC0316M9E8AN3  <b>NEW!</b> WH-WDG12ME5 WH-WDG12ME8	 WH-ADC0916M3E51 WH-ADC0916M3E52 1) WH-ADC0916M3E5AN2 WH-ADC0916M3E53 1) WH-ADC0916M3E5AN3 WH-ADC0316M9E81 WH-ADC0316M9E82 WH-ADC0316M9E8AN2 WH-ADC0316M9E83 WH-ADC0316M9E8AN3  <b>NEW!</b> WH-WDG16ME5 WH-WDG16ME8
		 WH-SDC0509L3E5 1) WH-WDG05LE5	 WH-SDC0509L3E5 1) WH-WDG07LE5	 WH-SDC0509L3E5 1) WH-WDG09LE5  WH-SDC0916M3E5 1) WH-SDC0316M9E8  <b>NEW!</b> WH-WDG09ME8	 WH-SDC0916M3E5 1) WH-SDC0316M9E8  <b>NEW!</b> WH-WDG12ME5 WH-WDG12ME8	 WH-SDC0916M3E5 1) WH-SDC0316M9E8  <b>NEW!</b> WH-WDG16ME5 WH-WDG16ME8
P. 55	 <b>Control module - R290</b> 1ph - 3ph			 WH-CME8  <b>NEW!</b> WH-WDG09ME8	 WH-CME5 WH-CME8  <b>NEW!</b> WH-WDG12ME5 WH-WDG12ME8	 WH-CME5 WH-CME8  <b>NEW!</b> WH-WDG16ME5 WH-WDG16ME8
				 <b>NEW!</b> WH-WDG09ME8	 <b>NEW!</b> WH-WDG12ME5 WH-WDG12ME8	 <b>NEW!</b> WH-WDG16ME5 WH-WDG16ME8
P. 58	 <b>Mono-bloc - R32</b> 1ph	 <b>NEW!</b> WH-MDC05J3E5-1	 <b>NEW!</b> WH-MDC07J3E5-1	 <b>NEW!</b> WH-MDC09J3E5-1		

Models with R290 refrigerant. Models with R32 refrigerant.  
 1) Also available with other backup heater capacities. 2) Requires CZ-RTW2TAW1C.  
 WH-\_\_E5 1ph // WH-\_\_E8 3ph.

# Aquarea Split

Aquarea T-CAP		9 kW	12 kW	16 kW
P. 59, 60, 61, 62	<b>All in One · R32 1ph - 3ph</b>	 <p>WH-ADC0912K6E5 WH-ADC0912K6E5AN WH-ADC0912K6E53 WH-ADC0912K6E5AN3 WH-UXZ09KE5</p> <p>WH-ADC0912K9E8 WH-ADC0912K9E8AN WH-ADC0912K9E83 WH-ADC0912K9E8AN3 WH-UXZ09KE8</p>	 <p>WH-ADC0912K6E5 WH-ADC0912K6E5AN WH-ADC0912K6E53 WH-ADC0912K6E5AN3 WH-UXZ12KE5</p> <p>WH-ADC0912K9E8 WH-ADC0912K9E8AN WH-ADC0912K9E83 WH-ADC0912K9E8AN3 WH-UXZ12KE8</p>	 <p>WH-ADC16K9E8 WH-ADC16K9E8AN WH-ADC16K9E83 WH-ADC16K9E8AN3 WH-UXZ16KE8</p>
	<b>Bi-bloc · R32 1ph - 3ph</b>	 <p>WH-SXC09K3E5 <sup>1)</sup> WH-UXZ09KE5</p> <p>WH-SXC09K3E8 <sup>1)</sup> WH-UXZ09KE8</p>	 <p>WH-SXC12K6E5 WH-UXZ12KE5</p> <p>WH-SXC12K9E8 WH-UXZ12KE8</p>	 <p>WH-SXC16K9E8 WH-UXZ16KE8</p>
<b>Aquarea T-CAP Super Quiet</b>		<b>9 kW</b>	<b>12 kW</b>	<b>16 kW</b>
P. 63, 64, 65, 66	<b>All in One · R32 3ph</b>	 <p><b>NEW!</b> WH-ADC0912K9E8 WH-ADC0912K9E8AN WH-ADC0912K9E83 WH-ADC0912K9E8AN3 WH-UQZ09KE8</p>	 <p><b>NEW!</b> WH-ADC0912K9E8 WH-ADC0912K9E8AN WH-ADC0912K9E83 WH-ADC0912K9E8AN3 WH-UQZ12KE8</p>	 <p><b>NEW!</b> WH-ADC16K9E8 WH-ADC16K9E8AN WH-ADC16K9E83 WH-ADC16K9E8AN3 WH-UQZ16KE8</p>
	<b>Bi-bloc · R32 3ph</b>	 <p><b>NEW!</b> WH-SXC09K9E8 <sup>1)</sup> WH-UQZ09KE8</p>	 <p><b>NEW!</b> WH-SXC12K9E8 WH-UQZ12KE8</p>	 <p><b>NEW!</b> WH-SXC16K9E8 WH-UQZ16KE8</p>

Models with R32 refrigerant.

<sup>1)</sup> Also available with other backup heater capacities.

WH-\_\_E5 1ph // WH-\_\_E8 3ph.



Check all our certified heat pumps on:  
[www.heatpumpkeymark.com](http://www.heatpumpkeymark.com)

Aquarea High Performance		3 kW	5 kW	7 kW	9 kW	12 kW	16 kW
P. 69, 70, 71, 72, 73, 74, 75, 76	All in One • R32 1ph - 3ph						
		WH-ADC0309K3E5 <sup>1)</sup> WH-ADC0309K3E5B WH-ADC0309K3E5AN <sup>1)</sup> WH-UDZ03KE5	WH-ADC0309K3E5 <sup>1)</sup> WH-ADC0309K3E5B WH-ADC0309K3E5AN <sup>1)</sup> WH-UDZ05KE5	WH-ADC0309K3E5 <sup>1)</sup> WH-ADC0309K3E5B WH-ADC0309K3E5AN <sup>1)</sup> WH-UDZ07KE5	WH-ADC0309K3E5 <sup>1)</sup> WH-ADC0309K3E5B WH-ADC0309K3E5AN <sup>1)</sup> WH-UDZ09KE5  WH-ADC0912K9E8 WH-ADC0912K9E8AN WH-ADC0912K9E83 WH-ADC0912K9E8AN3 WH-UDZ09KE8	WH-ADC0912K6E5 WH-ADC0912K6E5AN WH-ADC0912K6E53 WH-ADC0912K6E5AN3 WH-UDZ12KE5  WH-ADC0912K9E8 WH-ADC0912K9E8AN WH-ADC0912K9E83 WH-ADC0912K9E8AN3 WH-UDZ12KE8	WH-ADC16K6E5 WH-ADC16K6E5AN WH-ADC16K6E53 WH-ADC16K6E5AN3 WH-UDZ16KE5  WH-ADC16K9E8 WH-ADC16K9E8AN WH-ADC16K9E83 WH-ADC16K9E8AN3 WH-UDZ16KE8
P. 77, 78	Bi-bloc • R32 1ph - 3ph						
		WH-SDC0309K3E5 <sup>1)</sup> WH-UDZ03KE5	WH-SDC0309K3E5 <sup>1)</sup> WH-UDZ05KE5	WH-SDC0309K3E5 <sup>1)</sup> WH-UDZ07KE5	WH-SDC0309K3E5 <sup>1)</sup> WH-UDZ09KE5  WH-SDC09K3E8 <sup>1)</sup> WH-UDZ09KE8	WH-SDC12K6E5 WH-UDZ12KE5  WH-SDC12K9E8 WH-UDZ12KE8	WH-SDC16K6E5 WH-UDZ16KE5  WH-SDC16K9E8 WH-UDZ16KE8

Models with R32 refrigerant.  
 1) Also available with other backup heater capacities.  
 WH-\_\_E5 1ph // WH-\_\_E8 3ph.

Aquarea EcoFlex		7,1 kW	9,5 kW
P. 79	EcoFlex • R32 1ph		
		WH-ADF0309J3E5CM S-71WF3E CU-2WZ71YBE5	<b>NEW!</b> WH-ADF0309K3E5M WH-ADF0309K3E5ANM S-71WF3E CS-MZ16CKE CS-Z20CKEW CS-Z25CKEW CS-Z35CKEW CS-Z42CKEW CS-Z50CKEW CS-Z71CKEW CS-MZ20CD3EA CS-Z25CD3EAW CS-Z35CD3EAW CS-Z50CD3EAW CS-Z60CD3EAW CU-4WZ90CBE5

## Aquarea DHW Heat Pump

Aquarea DHW Heat Pump		100 L	150 L	200 L	260 L
P. 105	 Aquarea DHW Heat Pump • R290 1ph				
		P-DHW100AE5	P-DHW150AE5	P-DHW200AE5 P-DHW200CAE5	P-DHW260AE5 P-DHW260CAE5

## Aquarea T-CAP Hydraulic M Series outdoor units. Single phase / Three phase - R290

Natural refrigerant R290 with GWP 0,02.

**Energy efficiency:** A+++ in heating at 35 °C / Built-in flow meter.

**Flexibility:** Hydronic connection between indoor and outdoor / Built-in magnetic water filter.

**Comfort:** Constant capacity at 55 °C down to -15 °C / Operating range to -28 °C / Up to 75 °C flow temperature / 55 °C flow temperature at -25 °C / Low noise level

**Control:** Optimised user interface and improved features (2 zone control, bivalent control).

Check all our certified heat pumps on:  
[www.heatpumpkeymark.com](http://www.heatpumpkeymark.com)



\*For All in One.

Combination table					Outdoor unit					
Indoor unit					Heating capacity					
	DHW tank	Backup heater capacity	Electrical anode		Single phase		Three phase			
					9,0 kW	12,0 kW	9,0 kW	12,0 kW	16,0 kW	
					WH-WXG09ME5	WH-WXG12ME5	WH-WXG09ME8	WH-WXG12ME8	WH-WXG16ME8	
Hydraulic All in One	1ph	120 L	3 kW	—	WH-ADC0916M3E51	✓	✓	—	—	—
		185 L	3 kW	—	WH-ADC0916M3E52	✓	✓	—	—	—
		185 L	3 kW	✓	WH-ADC0916M3E5AN2	✓	✓	—	—	—
		185 L	6 kW	—	WH-ADC0916M6E52	✓	✓	—	—	—
		260 L	3 kW	—	WH-ADC0916M3E53	✓	✓	—	—	—
	3ph	260 L	3 kW	✓	WH-ADC0916M3E5AN3	✓	✓	—	—	—
		260 L	6 kW	—	WH-ADC0916M6E53	✓	✓	—	—	—
		120 L	9 kW	—	WH-ADC0316M9E81	✓	✓	✓	✓	✓
		185 L	9 kW	—	WH-ADC0316M9E82	✓	✓	✓	✓	✓
		185 L	9 kW	✓	WH-ADC0316M9E8AN2	✓	✓	✓	✓	✓
Hydraulic Bi-bloc	1ph	—	3 kW	—	WH-SDC0916M3E5	✓	✓	—	—	—
		—	6 kW	—	WH-SDC0916M6E5	✓	✓	—	—	—
	3ph	—	9 kW	—	WH-SDC0316M9E8	✓	✓	✓	✓	✓
Control module	1ph	—	—	—	WH-CME5	✓	✓	—	—	—
	3ph	—	—	—	WH-CME8	✓	✓	✓	✓	✓
Remote controller with Wi-Fi adapter	—	—	—	—	CZ-RTW2TAW1C	✓	✓	✓	✓	✓

Combination table - Big Aquarea T-CAP Hydraulic M Series					Outdoor unit		
Indoor unit					Heating capacity		
					Three phase		
					20,0 kW	25,0 kW	30,0 kW
					WH-WXG20ME8	WH-WXG25ME8	WH-WXG30ME8
Control module		3ph		WH-CME8L	✓	✓	✓
Remote controller with Wi-Fi adapter		—		CZ-RTW2TAW1C	✓	✓	✓

Accessories	
CZ-RTW2TAW1C	Remote controller with Wi-Fi adapter (required for stand-alone outdoor units). M Series
CZ-RTW2-1	Optional remote controller for 2 zone control. M Series
CZ-NS6P	PCB for advanced functions. M Series All in One and Bi-bloc
CZ-NS7P	PCB for advanced functions. M Series control module
PAW-A2W-RTWIRED	Room thermostat
PAW-A2W-RTWIRELESS	Wireless LCD room thermostat
PAW-A2W-AFVLV-112	1 antifreeze valve 1 1/2". It is required to order 2 valves per system. For 20, 25 and 30 kW
PAW-A2W-AFVLV-1	1 antifreeze valve 1". It is required to order 2 valves per system. For 9, 12 and 16 kW
PAW-TD20C1E5-1	Tank 200 L - Stainless steel
PAW-TD30C1E5-1	Tank 300 L - Stainless steel

Accessories	
PAW-TA20C1E5STD	Tank 200 L - Enamelled
PAW-TA30C1E5STD	Tank 300 L - Enamelled
PAW-TE50H1AE	Tank 500 L - Enamelled DHW
PAW-TE75H1AEAN	Tank 750 L - Enamelled DHW
PAW-TE90H1AEAN	Tank 900 L - Enamelled DHW
PAW-3WYVLV-HW	3 way valve for DHW tanks
PAW-BTANK50L-2	Buffer tank 50 L
PAW-BTANK100L	Buffer tank 100 L
PAW-BTANKG200L	Buffer tank 200 L
PAW-BTANKG260L	Buffer tank 260 L
PAW-BC50FAE	Buffer tank 500 L
PAW-BC80FAE	Buffer tank 800 L
PAW-BC100FAE	Buffer tank 1000 L



DHW A+: For All in One.

## Aquarea T-CAP Hydraulic M Series outdoor units.

Outdoor unit		WH-WXG09ME5	WH-WXG12ME5	WH-WXG09ME8	WH-WXG12ME8	WH-WXG16ME8	
Heating capacity / COP (A +7 °C, W 35 °C)	kW / COP	9,00/5,23	12,00/5,06	9,00/5,23	12,00/5,06	16,00/4,89	
Heating capacity / COP (A +7 °C, W 55 °C)	kW / COP	9,00/3,24	12,00/3,23	9,00/3,24	12,00/3,23	16,00/3,20	
Heating capacity / COP (A +2 °C, W 35 °C)	kW / COP	9,00/3,81	12,00/3,54	9,00/3,81	12,00/3,54	16,00/3,30	
Heating capacity / COP (A +2 °C, W 55 °C)	kW / COP	9,00/2,54	12,00/2,42	9,00/2,54	12,00/2,42	16,00/2,37	
Heating capacity / COP (A -7 °C, W 35 °C)	kW / COP	9,00/3,45	12,00/3,00	9,00/3,45	12,00/3,00	16,00/2,53	
Heating capacity / COP (A -7 °C, W 55 °C)	kW / COP	9,00/2,35	12,00/2,17	9,00/2,35	12,00/2,17	16,00/1,97	
Cooling capacity / EER (A 35 °C, W 7 °C)	kW / EER	9,00/3,61	9,00/3,61	9,00/3,61	9,00/3,61	9,00/3,61	
Cooling capacity / EER (A 35 °C, W 18 °C)	kW / EER	9,00/5,26	12,00/5,26	9,00/5,26	12,00/5,26	16,00/5,26	
Heating average climate (W 35 °C / W 55 °C)	Seasonal energy efficiency	SCOP ( $\eta_s$ %)	4,96/3,57(195/140)	5,00/3,46(197/135)	5,00/3,50(197/137)	4,73/3,65(186/143)	4,75/3,70(187/115)
	Energy class <sup>1)</sup>	A+++ to D	A+++/A++	A+++/A++	A+++/A++	A+++/A++	A+++/A++
Heating warm climate (W 35 °C / W 55 °C)	Seasonal energy efficiency	SCOP ( $\eta_s$ %)	6,47/4,34(256/171)	6,47/4,34(256/171)	6,33/4,40(250/173)	6,20/4,40(245/173)	6,08/4,45(240/175)
	Energy class <sup>1)</sup>	A+++ to D	A+++/A+++	A+++/A+++	A+++/A+++	A+++/A+++	A+++/A+++
Heating cold climate (W 35 °C / W 55 °C)	Seasonal energy efficiency	SCOP ( $\eta_s$ %)	4,31/3,26(169/127)	4,31/3,26(169/127)	4,45/3,20(175/125)	4,38/3,25(172/127)	4,33/3,40(170/133)
	Energy class <sup>1)</sup>	A+++ to D	A++/A++	A++/A++	A+++/A++	A++/A++	A++/A++
Sound power <sup>2)</sup>	Heat	dB(A)	52	53	52	53	57
Dimension	H x W x D	mm	1520 x 1200 x 430	1520 x 1200 x 430	1520 x 1200 x 430	1520 x 1200 x 430	1520 x 1200 x 430
Net weight		kg	161	161	161	161	165
A class pump	Number of speeds		Variable speed	Variable speed	Variable speed	Variable speed	Variable speed
	Input power (Min/Max)	W	30/175	30/175	30/175	30/175	30/175
Heating water flow ( $\Delta T=5$ K, 35 °C)	L/min		25,8	34,4	25,8	34,4	45,9
Refrigerant (R290) / CO <sub>2</sub> Eq. <sup>3)</sup>	kg / T		1,78/0,00004	1,78/0,00004	1,78/0,00004	1,78/0,00004	1,78/0,00004
Operating range - outdoor ambient	Heat	°C	-28 ~ +35	-28 ~ +35	-28 ~ +35	-28 ~ +35	-28 ~ +35
	Cool	°C	+10 ~ +43	+10 ~ +43	+10 ~ +43	+10 ~ +43	+10 ~ +43
	DHW	°C	-28 ~ +43	-28 ~ +43	-28 ~ +43	-28 ~ +43	-28 ~ +43
Water outlet	Heat / Cool	°C	25 ~ 75 <sup>4)</sup> / 5 ~ 20	25 ~ 75 <sup>4)</sup> / 5 ~ 20	25 ~ 75 <sup>4)</sup> / 5 ~ 20	25 ~ 75 <sup>4)</sup> / 5 ~ 20	25 ~ 75 <sup>4)</sup> / 5 ~ 20
Recommended fuse, supply <sup>5)</sup>		A	30	30	20	20	25
Recommended minimum cable size, supply <sup>5)</sup>		mm <sup>2</sup>	3x4,0	3x4,0	5x1,5	5x1,5	5x2,5

1) Scale from A+++ to D. 2) Sound power level in accordance to EN 12102 under conditions of the EN14825 (part load). 3) WH-WXG models are hermetically sealed. 4) Above -15 °C outdoor temperature. Between outdoor ambient -15 °C and -25 °C, the water outlet temperature gradually decreases from 75 °C to 55 °C. Below -25 °C outdoor temperature maximum water outlet temperature is 55 °C. 5) Check local regulations. \*EER and COP calculation is based in accordance to EN 14511.

## Big Aquarea T-CAP Hydraulic M Series outdoor units.

Outdoor unit		WH-WXG20ME8	WH-WXG25ME8	WH-WXG30ME8	
Heating capacity / COP (A +7 °C, W 35 °C)	kW / COP	20,00/4,80	25,00/4,50	30,00/4,40	
Heating capacity / COP (A +7 °C, W 55 °C)	kW / COP	20,00/3,18	25,00/3,00	30,00/3,00	
Heating capacity / COP (A +2 °C, W 35 °C)	kW / COP	20,00/3,39	25,00/2,80	30,00/2,50	
Heating capacity / COP (A +2 °C, W 55 °C)	kW / COP	20,00/2,08	25,00/1,97	30,00/1,95	
Heating capacity / COP (A -7 °C, W 35 °C)	kW / COP	20,00/2,48	25,00/2,36	30,00/2,33	
Heating capacity / COP (A -7 °C, W 55 °C)	kW / COP	20,00/1,90	25,00/1,80	30,00/1,49	
Cooling capacity / EER (A 35 °C, W 7 °C) at Comfort mode	kW / EER	20,00/3,02	25,00/2,86	26,00/2,68	
Cooling capacity / EER (A 35 °C, W 7 °C) at Efficiency mode (default)	kW / EER	15,00/3,61	15,00/3,61	15,00/3,61	
Cooling capacity / EER (A 35 °C, W 18 °C) at Comfort mode	kW / EER	20,00/4,79	25,00/4,47	30,00/4,10	
Heating average climate (W 35 °C / W 55 °C)	Seasonal energy efficiency	SCOP ( $\eta_s$ %)	4,36/3,59 (171/141)	4,25/3,57 (167/140)	3,95/3,46 (155/135)
	Energy class <sup>1)</sup>	A+++ to D	A++/A++	A++/A++	A++/A++
Heating warm climate (W 35 °C / W 55 °C)	Seasonal energy efficiency	SCOP ( $\eta_s$ %)	5,37/4,07 (212/160)	5,22/4,14 (206/163)	4,93/4,01 (194/158)
	Energy class <sup>1)</sup>	A+++ to D	A+++/A+++	A+++/A+++	A+++/A+++
Heating cold climate (W 35 °C / W 55 °C)	Seasonal energy efficiency	SCOP ( $\eta_s$ %)	3,07/2,57 (120/100)	3,16/2,71 (123/105)	3,20/2,71 (125/105)
	Energy class <sup>1)</sup>	A+++ to D	A/A+	A+/A+	A+/A+
Sound power <sup>2)</sup>	Heat	dB(A)	56	59	61
Dimension	H x W x D	mm	1645 x 1500 x 460	1645 x 1500 x 460	1645 x 1500 x 460
Net weight		kg	240	240	240
A class pump	Number of speeds		Variable speed	Variable speed	Variable speed
	Input power (Min/Max)	W	230	230	230
Heating water flow ( $\Delta T=5$ K, 35 °C)	L/min		57,3	71,6	86,0
Refrigerant (R290) / CO <sub>2</sub> Eq. <sup>3)</sup>	kg / T		3,0/0,00006	3,0/0,00006	3,0/0,00006
Operating range - outdoor ambient	Heat	°C	-25 ~ +35	-25 ~ +35	-25 ~ +35
	Cool	°C	+10 ~ +43	+10 ~ +43	+10 ~ +43
Water outlet	Heat / Cool	°C	20 ~ 75 <sup>4)</sup> / 5 ~ 20	20 ~ 75 <sup>4)</sup> / 5 ~ 20	20 ~ 75 <sup>4)</sup> / 5 ~ 20
Recommended fuse, supply <sup>5)</sup>		A	50	50	50
Recommended minimum cable size, supply <sup>5)</sup>		mm <sup>2</sup>	5x10 - 5x16	5x10 - 5x16	5x10 - 5x16

1) Scale from A+++ to D. 2) Sound power level in accordance to EN 12102 under conditions of the EN14825 (part load). 3) WH-WXG models are hermetically sealed. 4) Above 15 °C ambient temperature. 5) Check local regulations. \*EER and COP calculation is based in accordance to EN 14511.

## Aquarea T-CAP Hydraulic M Series indoor units. Single phase / Three phase - R290

Natural refrigerant R290 with GWP 0,02.

**Control:** All control functions / 2 CN-CNT ports / Optional PCB for advanced functions.

**Connectivity:** Wi-Fi adapter included for smart control via Comfort Cloud App / Optional integration into BMS.



\*For All in One.

### Control module:

**Flexibility:** Simplified installation / Minimal interior space required / Supports third-party backup heater.

Indoor unit		WH-CME5	WH-CME8	WH-CME8L
Dimension / Net weight	H x W x D	mm / kg	454 x 520 x 116 / 7	454 x 520 x 116 / 7
Field supply electrical backup heater		kW	Up to 3 kW	Up to 9 kW
Recommended fuse, supply <sup>1)</sup>		A	16	30
Recommended minimum cable size, supply <sup>1)</sup>		mm <sup>2</sup>	3x1,5	3x4,0
Connecting cable to the outdoor unit size		mm <sup>2</sup>	2x0,75	2x0,75

<sup>1)</sup> Check local regulations.

### Bi-bloc:

**Flexibility:** Flexible choice of DHW tank size.

Indoor unit		WH-SDC0916M3E5	WH-SDC0916M6E5	WH-SDC0316M9E8
Sound pressure	Heat / Cool	dB(A)	22/22	22/22
Dimension / Net weight	H x W x D	mm / kg	892 x 500 x 348 / 28	892 x 500 x 348 / 29
Water pipe connector	Room	Inch	1¼	1¼
Water pipe connector (indoor / outdoor units)		Inch	1¼/1¼	1¼/1¼
Pipe length range standard / maximum		m	5/30	5/30
Elevation difference (in / out)		m	30	30

Electrical information for Bi-bloc and All in One indoor units		Single phase (3 kW heater)	Single phase (6 kW heater)	Three phase (9 kW heater)
Electric backup heater	kW	3,00	6,00	9,00
Recommended fuse, supply <sup>1)</sup>	A	16	30	20
Recommended minimum cable size, supply <sup>1)</sup>	mm <sup>2</sup>	3x1,5	3x4,0	5x1,5
Connecting cable to the outdoor unit size	mm <sup>2</sup>	2x0,75	2x0,75	2x0,75

<sup>1)</sup> Check local regulations. \*This product is designed to comply with the European drinking water standard (EU) 2020/2184. The lifespan of the product is not guaranteed in the case of the use of groundwater, such as spring water or well water, the use of tap water when salt or other impurities are contained, nor in areas of acidic water quality. Maintenance and warranty costs related to these cases are the customer's responsibility.

Accessories	
CZ-RTW2TAW1C	Remote controller with Wi-Fi adapter (required for stand-alone outdoor units). M Series
CZ-RTW2-1	Optional remote controller for 2 zone control. M Series
CZ-NS6P	PCB for advanced functions. M Series All in One and Bi-bloc
CZ-NS7P	PCB for advanced functions. M Series control module
PAW-A2W-RTWIRED	Room thermostat
PAW-A2W-RTWIRELESS	Wireless LCD room thermostat
CZ-NV3	3 way valve kit to fit inside the hydrokit. M Series
PAW-TD20C1E5-1	Tank 200 L - Stainless steel
PAW-TD30C1E5-1	Tank 300 L - Stainless steel
PAW-TA20C1E5STD	Tank 200 L - Enamelled

Accessories	
PAW-TA30C1E5STD	Tank 300 L - Enamelled
PAW-TE50H1AE	Tank 500 L - Enamelled DHW
PAW-TE75H1AEAN	Tank 750 L - Enamelled DHW
PAW-TE90H1AEAN	Tank 900 L - Enamelled DHW
PAW-3WYVLV-HW	3 way valve for DHW tanks
PAW-BTANK50L-2	Buffer tank 50 L
PAW-BTANK100L	Buffer tank 100 L
PAW-BTANKG200L	Buffer tank 200 L
PAW-BTANKG260L	Buffer tank 260 L
PAW-BC50FAE	Buffer tank 500 L
PAW-BC80FAE	Buffer tank 800 L
PAW-BC100FAE	Buffer tank 1000 L



DHW A+: For All in One.

## All in One:

**Energy efficiency:** A+ in DHW / DHW up to 65 °C without heater / Stainless steel DHW tank with U-Vacua™.

**Flexibility:** Backup heater included / Built-in 10 L expansion vessel / 30 m maximum height difference between indoor and outdoor / Suitable for harsh-water installations (AN version).

All in One with 120 L DHW tank*			Single phase	Three phase
Indoor unit			WH-ADC0916M3E51	WH-ADC0316M9E81
Dimension / Net weight	H x W x D	mm / kg	1293 x 599 x 602 / 74	1293 x 599 x 602 / 74
Water volume		L	120	120
Electric backup heater		kW	3,00	9,00

## Domestic Hot Water energy efficiency

Indoor unit		WH-ADC0916M3E51	WH-ADC0916M3E51	WH-ADC0316M9E81	WH-ADC0316M9E81	WH-ADC0316M9E81
Outdoor unit		WH-WXG09ME5	WH-WXG12ME5	WH-WXG09ME8	WH-WXG12ME8	WH-WXG16ME8
Tapping profile according EN16147		L	L	L	L	L
DHW tank ERP efficiency average / warm / cold <sup>1)</sup>	A+ to F	A+ / A / A	A+ / A / A	A+ / A / A	A+ / A / A	A+ / A / A
DHW tank ERP average climate $\eta$ / COPdHW	$\eta_{wh} \%$ / COPdHW	96 / 2,41	96 / 2,41	96 / 2,41	96 / 2,41	96 / 2,41
DHW tank ERP warm climate $\eta$ / COPdHW	$\eta_{wh} \%$ / COPdHW	101 / 2,7	101 / 2,7	101 / 2,7	101 / 2,7	101 / 2,7
DHW tank ERP cold climate $\eta$ / COPdHW	$\eta_{wh} \%$ / COPdHW	70 / 1,75	70 / 1,75	70 / 1,75	70 / 1,75	70 / 1,75

## All in One with 185 L DHW tank

All in One with 185 L DHW tank			Single phase	Three phase	
Indoor unit			WH-ADC0916M3E52	WH-ADC0916M6E52	WH-ADC0316M9E82
Indoor unit with Electrical Anode			WH-ADC0916M3E5AN2	—	WH-ADC0316M9E8AN2
Dimension / Net weight	H x W x D	mm / kg	1642 x 599 x 602 / 89	1642 x 599 x 602 / 89	1642 x 599 x 602 / 89
Water volume		L	185	185	185
Electric backup heater		kW	3,00	6,00	9,00

## Domestic Hot Water energy efficiency

Indoor unit		WH-ADC0916M3E52	WH-ADC0916M3E52	WH-ADC0316M9E82	WH-ADC0316M9E82	WH-ADC0316M9E82
Indoor unit		WH-ADC0916M6E52	WH-ADC0916M6E52	—	—	—
Indoor unit		WH-ADC0916M3E5AN2	WH-ADC0916M3E5AN2	WH-ADC0316M9E8AN2	WH-ADC0316M9E8AN2	WH-ADC0316M9E8AN2
Outdoor unit		WH-WXG09ME5	WH-WXG12ME5	WH-WXG09ME8	WH-WXG12ME8	WH-WXG16ME8
Tapping profile according EN16147		L	L	L	L	L
DHW tank ERP efficiency average / warm / cold <sup>1)</sup>	A+ to F	A+ / A+ / A	A+ / A+ / A	A+ / A+ / A	A+ / A+ / A	A+ / A+ / A
DHW tank ERP average climate $\eta$ / COPdHW	$\eta_{wh} \%$ / COPdHW	123 / 3,00	123 / 3,00	123 / 3,00	123 / 3,00	117 / 2,85
DHW tank ERP warm climate $\eta$ / COPdHW	$\eta_{wh} \%$ / COPdHW	132 / 3,30	132 / 3,30	132 / 3,30	132 / 3,30	128 / 3,20
DHW tank ERP cold climate $\eta$ / COPdHW	$\eta_{wh} \%$ / COPdHW	88 / 2,20	88 / 2,20	88 / 2,20	88 / 2,20	84 / 2,10

## All in One with 260 L DHW tank

All in One with 260 L DHW tank			Single phase	Three phase	
Indoor unit			WH-ADC0916M3E53	WH-ADC0916M6E53	WH-ADC0316M9E83
Indoor unit with Electrical Anode			WH-ADC0916M3E5AN3	—	WH-ADC0316M9E8AN3
Dimension / Net weight	H x W x D	mm / kg	2036 x 599 x 602 / 105	2036 x 599 x 602 / 105	2036 x 599 x 602 / 105
Water volume		L	260	260	260
Electric backup heater		kW	3,00	6,00	9,00

## Domestic Hot Water energy efficiency

Indoor unit		WH-ADC0916M3E53	WH-ADC0916M3E53	WH-ADC0316M9E83	WH-ADC0316M9E83	WH-ADC0316M9E83
Indoor unit		WH-ADC0916M6E53	WH-ADC0916M6E53	—	—	—
Indoor unit		WH-ADC0916M3E5AN3	WH-ADC0916M3E5AN3	WH-ADC0316M9E8AN3	WH-ADC0316M9E8AN3	WH-ADC0316M9E8AN3
Outdoor unit		WH-WXG09ME5	WH-WXG12ME5	WH-WXG09ME8	WH-WXG12ME8	WH-WXG16ME8
Tapping profile according EN16147		XL	XL	XL	XL	XL
DHW tank ERP efficiency average / warm / cold <sup>1)</sup>	A+ to F	A+ / A+ / A	A+ / A+ / A	A+ / A+ / A	A+ / A+ / A	A / A+ / A
DHW tank ERP average climate $\eta$ / COPdHW	$\eta_{wh} \%$ / COPdHW	123 / 3,00	123 / 3,00	125 / 3,10	125 / 3,10	115 / 2,85
DHW tank ERP warm climate $\eta$ / COPdHW	$\eta_{wh} \%$ / COPdHW	132 / 3,30	132 / 3,30	136 / 3,35	136 / 3,35	129 / 3,20
DHW tank ERP cold climate $\eta$ / COPdHW	$\eta_{wh} \%$ / COPdHW	88 / 2,20	88 / 2,20	95 / 2,35	95 / 2,35	85 / 2,10

## All in One Indoor units technical data

Sound pressure	Heat / Cool	dB(A)	22 / 22
Water pipe connector	Room / Shower	Inch	1 1/4 / 3/4
Maximum DHW temperature		°C	65
Material inside tank			Stainless steel
Water pipe connector (indoor / outdoor units)		Inch	1 1/4 / 1 1/4
Pipe length range standard / maximum		m	5 / 30
Elevation difference (in / out)		m	30

1) Scale from A+ to F. \*This product is designed to comply with the European drinking water standard (EU) 2020/2184. The lifespan of the product is not guaranteed in the case of the use of groundwater, such as spring water or well water, the use of tap water when salt or other impurities are contained, nor in areas of acidic water quality. Maintenance and warranty costs related to these cases are the customer's responsibility.

## Aquarea T-CAP Mono-bloc J Series. Single phase / Three phase - MXC - R32

**Energy efficiency:** A+++ in heating at 35 °C / "A" water pump with variable speed / Built-in flow meter.

**Flexibility:** Built-in magnetic water filter.

**Comfort:** Constant capacity at 55 °C down to -15 °C / 65 °C water outlet temperature.

**Control:** Additional functions with optional PCB (2 zone control, bivalent control, Smart Grid contact and more).

**Connectivity:** Optional Wi-Fi and BMS integration.

Check all our certified heat pumps on:  
[www.heatpumpkeymark.com](http://www.heatpumpkeymark.com)



Optional

Outdoor unit	Single phase					Three phase	
	WH-MXC09J3E5-1	WH-MXC12J6E5-1	WH-MXC09J3E8-1	WH-MXC12J9E8-1	WH-MXC16J9E8-1		
Heating capacity / COP (A +7 °C, W 35 °C)	kW / COP	9,00/5,08	12,00/4,80	9,00/5,08	12,00/4,80	16,00/4,52	
Heating capacity / COP (A +7 °C, W 55 °C)	kW / COP	9,00/3,08	12,00/3,05	9,00/3,08	12,00/3,05	16,00/2,86	
Heating capacity / COP (A +2 °C, W 35 °C)	kW / COP	9,00/3,81	12,00/3,53	9,00/3,81	12,00/3,53	16,00/3,10	
Heating capacity / COP (A +2 °C, W 55 °C)	kW / COP	9,00/2,54	12,00/2,42	9,00/2,54	12,00/2,42	16,00/2,07	
Heating capacity / COP (A -7 °C, W 35 °C)	kW / COP	9,00/3,08	12,00/2,82	9,00/3,08	12,00/2,82	16,00/2,39	
Heating capacity / COP (A -7 °C, W 55 °C)	kW / COP	9,00/2,12	12,00/2,00	9,00/2,12	12,00/2,00	16,00/1,71	
Cooling capacity / EER (A 35 °C, W 7 °C)	kW / EER	9,00/3,18	12,00/2,90	9,00/3,09	12,00/2,84	14,50/2,84	
Cooling capacity / EER (A 35 °C, W 18 °C)	kW / EER	9,00/4,62	12,00/3,95	9,00/4,46	12,00/3,79	16,00/3,75	
Heating average climate (W 35 °C / W 55 °C)	Seasonal energy efficiency	SCOP (η <sub>s</sub> %)	4,96/3,57(195/140)	4,96/3,57(195/140)	4,96/3,57(195/140)	4,96/3,57(195/140)	4,46/3,31(176/129)
	Energy class <sup>1)</sup>	A+++ to D	A+++/A++	A+++/A++	A+++/A++	A+++/A++	A+++/A++
Heating warm climate (W 35 °C / W 55 °C)	Seasonal energy efficiency	SCOP (η <sub>s</sub> %)	6,47/4,34(256/171)	6,47/4,34(256/171)	6,47/4,34(256/171)	6,47/4,34(256/171)	5,88/4,09(232/160)
	Energy class <sup>1)</sup>	A+++ to D	A+++/A+++	A+++/A+++	A+++/A+++	A+++/A+++	A+++/A+++
Heating cold climate (W 35 °C / W 55 °C)	Seasonal energy efficiency	SCOP (η <sub>s</sub> %)	4,31/3,26(169/127)	4,31/3,26(169/127)	4,31/3,26(169/127)	4,31/3,26(169/127)	3,83/3,20(150/125)
	Energy class <sup>1)</sup>	A+++ to D	A++/A++	A++/A++	A++/A++	A++/A++	A++/A++
Sound power <sup>2)</sup>	Heat	dB(A)	61	61	61	61	63
Dimension	HxWxD	mm	1410x1283x320	1410x1283x320	1410x1283x320	1410x1283x320	1410x1283x320
Net weight		kg	140	140	140	140	150
Refrigerant (R32) / CO <sub>2</sub> Eq. <sup>3)</sup>		kg / T	1,60/1,080	1,60/1,080	1,60/1,080	1,60/1,080	1,80/1,215
Water pipe connector		Inch	R 1½	R 1½	R 1½	R 1½	R 1½
Pump	Number of speeds		Variable speed	Variable speed	Variable speed	Variable speed	Variable speed
	Input power (Min/Max)	W	32/145	34/145	145	145	145
Heating water flow (ΔT=5 K, 35 °C)		L/min	25,8	34,4	25,8	34,4	45,9
Electric backup heater		kW	3,00	6,00	3,00	9,00	9,00
Input power	Heat	kW	1,77	2,50	1,77	2,50	3,54
	Cool	kW	2,83	4,14	2,91	4,23	5,11
Running and starting current	Heat	A	8,3	11,6	2,6	3,7	5,3
	Cool	A	13,1	19,1	4,3	6,3	7,6
Current 1		A	29,0	29,0	14,7	11,8	16,4
Current 2		A	13,0	26,0	13,0	13,0	13,0
Recommended fuse, supply 1 / 2 <sup>4)</sup>		A	30/30	30/30	20/16	20/20	20/20
Recommended minimum cable size, supply 1 / 2 <sup>4)</sup>		mm <sup>2</sup>	3x4,0/3x4,0	3x4,0/3x4,0	5x1,5/3x1,5	5x1,5/5x1,5	5x2,5/5x1,5
Operating range - outdoor ambient	Heat	°C	-20 ~ +35	-20 ~ +35	-20 ~ +35	-20 ~ +35	-20 ~ +35
	Cool	°C	10 ~ +43	10 ~ +43	10 ~ +43	10 ~ +43	10 ~ +43
Water outlet <sup>5)</sup>	Heat	°C	20 ~ 65	20 ~ 65	20 ~ 65	20 ~ 65	20 ~ 65
	Cool	°C	5 ~ 20	5 ~ 20	5 ~ 20	5 ~ 20	5 ~ 20

1) Scale from A+++ to D. 2) Sound power level in accordance to EN 12102 under conditions of the EN14825. 3) WH-MXC models are hermetically sealed. 4) Check local regulations. 5) It is possible to set temperature by 65 °C on remote controller. Normally, outlet water temperature is 60 °C or lower. In case of ΔT setting with remote controller is 15 °C and the outdoor ambient temperature is 5 to 20 °C, outlet water temperature 65 °C is possible. \*EER and COP calculation is based in accordance to EN 14511.

Accessories	
<b>PAW-TD20C1E5-1</b>	Tank 200 L - Stainless steel
<b>PAW-TD30C1E5-1</b>	Tank 300 L - Stainless steel
<b>PAW-TA20C1E5STD</b>	Tank 200 L - Enamelled
<b>PAW-TA30C1E5STD</b>	Tank 300 L - Enamelled
<b>PAW-TD20B8E3-2</b>	Combo Tank 185 L + 80 L - Enamelled
<b>PAW-TD23B6E5</b>	Combo Tank 230 L + 60 L - Stainless steel
<b>PAW-3WYVLV-HW</b>	3 way valve for DHW tanks
<b>PAW-BTANK50L-2</b>	Buffer tank 50 L

Accessories	
<b>CZ-TAW1B</b>	Optional Wi-Fi or WLAN adapter for smart control via Comfort Cloud App and/or remote maintenance via Aquarea Service Cloud
<b>CZ-TAW1-CBL</b>	10 m extension cable for CZ-TAW1B
<b>PAW-A2W-AFVLV-1</b>	1 antifreeze valve 1". It is required to order 2 valves per system
<b>PAW-A2W-RTWIRED</b>	Room thermostat
<b>PAW-A2W-RTWIRELESS</b>	Wireless LCD room thermostat



# Validating efficiency and performance of Aquarea Heat Pumps

Aquarea Heat Pumps achieve outstanding efficiency and performance, validated through ErP labels and Keymark certifications. These credentials ensure that Aquarea Heat Pumps deliver reliable and sustainable heating solutions.

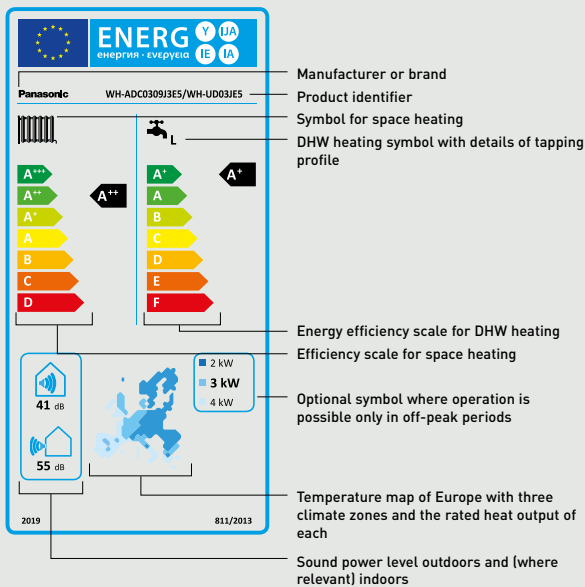

## Energy labels: guiding consumers to energy savings.

Energy labels help consumers make informed purchasing decisions and support Ecodesign requirements that reduce energy demand and combat global warming. Heat pumps are classified into seven efficiency categories, from A+++ (most efficient) to D (least efficient). For hot water cylinders, the range is from A+ to F. Thanks to advanced technologies, Panasonic offers solutions that achieve the highest energy ratings, ensuring high-efficiency and performance.



## Keymark certification: a mark of quality and reliability.

The Keymark certification is a quality mark that demonstrates compliance with European standards. Issued by independent certification bodies, it ensures products meet rigorous quality and performance criteria. Aquarea Heat Pumps proudly carry the Keymark certification, validating their exceptional efficiency and reliability.



Check all our certified heat pumps on: [www.heatpumpkeymark.com](http://www.heatpumpkeymark.com)



## Aquarea High Performance Hydraulic L Series. Single phase - R290

Natural refrigerant R290 with GWP 0,02.

**Energy efficiency:** A+++ in heating at 35 °C.

**Flexibility:** Hydronic connection between indoor and outdoor / Built-in magnetic water filter.

**Comfort:** Operation without backup heater down to -25 °C / 75 °C flow temperature at -10 °C / 55 °C flow temperature at -25 °C.

Check all our certified heat pumps on:  
[www.heatpumpkeymark.com](http://www.heatpumpkeymark.com)



Included

\*For All in One.

Combination table						Outdoor unit			
Indoor unit						Heating capacity			
	DHW tank	Backup heater capacity	2 zones	Electrical anode		Single phase (power to indoor)			
						5,0 kW	7,0 kW	9,0 kW	
						WH-WDG05LE5	WH-WDG07LE5	WH-WDG09LE5	
Hydraulic All in One	1ph	120 L	3 kW	—	—	WH-ADC0509L3E51	✓	✓	✓
		185 L	3 kW	—	—	WH-ADC0509L3E5	✓	✓	✓
		185 L	3 kW	—	✓	WH-ADC0509L3E5AN	✓	✓	✓
		185 L	6 kW	—	—	WH-ADC0509L6E5	✓	✓	✓
		185 L	6 kW	—	✓	WH-ADC0509L6E5AN	✓	✓	✓
		185 L	3 kW	✓	—	WH-ADC0509L3E5B	✓	✓	✓
Hydraulic Bi-bloc	1ph	—	3 kW	—	—	WH-SDC0509L3E5	✓	✓	✓
		—	6 kW	—	—	WH-SDC0509L6E5	✓	✓	✓

Outdoor unit		WH-WDG05LE5	WH-WDG07LE5	WH-WDG09LE5	
Heating capacity / COP (A +7 °C, W 35 °C)	kW / COP	5,00/5,05	7,00/4,93	9,00/4,55	
Heating capacity / COP (A +7 °C, W 55 °C)	kW / COP	5,00/3,07	7,00/2,98	8,90/3,03	
Heating capacity / COP (A +2 °C, W 35 °C)	kW / COP	5,00/3,52	6,85/3,43	7,00/3,41	
Heating capacity / COP (A +2 °C, W 55 °C)	kW / COP	5,00/2,34	6,25/2,34	7,00/2,41	
Heating capacity / COP (A -7 °C, W 35 °C)	kW / COP	5,00/3,01	5,80/3,01	7,00/2,80	
Heating capacity / COP (A -7 °C, W 55 °C)	kW / COP	5,00/2,12	5,80/2,12	7,00/2,13	
Cooling capacity / EER (A 35 °C, W 7 °C)	kW / EER	5,00/3,23	7,00/3,03	8,20/2,82	
Cooling capacity / EER (A 35 °C, W 18 °C)	kW / EER	5,00/5,00	7,00/4,73	9,00/4,19	
Heating average climate (W 35 °C / W 55 °C)	Seasonal energy efficiency	SCOP (η <sub>s</sub> %)	5,06/3,63(200/142)	4,96/3,62(195/142)	4,84/3,67(190/144)
	Energy class <sup>1)</sup>	A+++ to D	A+++/A++	A+++/A++	A+++/A++
Heating warm climate (W 35 °C / W 55 °C)	Seasonal energy efficiency	SCOP (η <sub>s</sub> %)	6,00/4,27(237/168)	6,31/4,52(249/178)	6,44/4,50(255/177)
	Energy class <sup>1)</sup>	A+++ to D	A+++/A+++	A+++/A+++	A+++/A+++
Heating cold climate (W 35 °C / W 55 °C)	Seasonal energy efficiency	SCOP (η <sub>s</sub> %)	4,25/3,28(167/128)	4,25/3,29(167/129)	4,31/3,33(170/130)
	Energy class <sup>1)</sup>	A+++ to D	A++/A++	A++/A++	A++/A++
Sound power <sup>2)</sup>	Heat	dB(A)	52	53	54
Dimension / Net weight	H x W x D	mm / kg	996 x 980 x 430 / 98	996 x 980 x 430 / 98	996 x 980 x 430 / 97
Refrigerant (R290) / CO <sub>2</sub> Eq.		kg / T	0,96/0,00002	0,96/0,00002	1,00/0,00002
Operating range - outdoor ambient	Heat	°C	-25 ~ +35	-25 ~ +35	-25 ~ +35
	Cool	°C	+10 ~ +43	+10 ~ +43	+10 ~ +43
Water outlet	Heat / Cool	°C	20 ~ 75/5 ~ 20	20 ~ 75/5 ~ 20	20 ~ 75/5 ~ 20

1) Scale from A+++ to D. 2) Sound power level in accordance to EN 12102 under conditions of the EN14825 (part load). \*EER and COP calculation is based in accordance to EN 14511.



DHW A+: For All in One.

## All in One:

**Energy efficiency:** A+ in DHW / DHW up to 65 °C without heater / Stainless steel DHW tank with U-Vacua™.

**Flexibility:** Built-in 2 zone kit (for 2 zones models) / Suitable for harsh-water installations (AN version).

**Control:** Optimised user interface and improved features (2 zone control, bivalent control).

**Connectivity:** Wi-Fi adapter included for smart control via Comfort Cloud App.

Indoor unit			WH-ADC0509L3E51	WH-ADC0509L3E5	WH-ADC0509L6E5
Indoor unit 2 zones			—	WH-ADC0509L3E5B	—
Indoor unit with Electrical Anode			—	WH-ADC0509L3E5AN	WH-ADC0509L6E5AN
Sound pressure	Heat / Cool	dB(A)	31/31	28/28	28/28
Dimension	H x W x D	mm	1293 x 599 x 602	1642 x 599 x 602	1642 x 599 x 602
Net weight / 2 zones model		kg	79/—	93/101	94/—
Water pipe connector	Room	Inch	1¼	1¼	1¼
	Shower	Inch	¾	¾	¾
A class pump	Number of speeds		Variable speed	Variable speed	Variable speed
	Input power (Min/Max)	W	30/145	30/145	30/145
Heating water flow (ΔT=5 K, 35 °C)		L/min	14,3	14,3	25,8
Water volume		L	120	185	185
Maximum DHW temperature		°C	65	65	65
Material inside tank			Stainless steel	Stainless steel	Stainless steel
Water pipe connector (indoor / outdoor units)		Inch	1/1	1/1	1/1
Pipe length range standard / maximum		m	5/30	5/30	5/30
Elevation difference (in / out)		m	10	10	10
Electric backup heater		kW	3,00	3,00	6,00
Recommended fuse, supply 1 / 2 <sup>1)</sup>		A	25/16	25/16	25/30
Recommended minimum cable size, supply 1 / 2 <sup>1)</sup>		mm <sup>2</sup>	3x2,5/3x1,5	3x2,5/3x1,5	3x2,5/3x4,0

Domestic Hot Water energy efficiency		120 L	185 L	120 L	185 L	120 L	185 L
		ADC0509L3E51	ADC0509L3E5	ADC0509L3E51	ADC0509L3E5	ADC0509L3E51	ADC0509L3E5
Indoor unit	WH-	—	ADC0509L3E5AN	—	ADC0509L3E5AN	—	ADC0509L3E5AN
		—	ADC0509L3E5B	—	ADC0509L3E5B	—	ADC0509L3E5B
		—	ADC0509L6E5	—	ADC0509L6E5	—	ADC0509L6E5
		—	ADC0509L6E5AN	—	ADC0509L6E5AN	—	ADC0509L6E5AN
		—	ADC0509L6E5AN	—	ADC0509L6E5AN	—	ADC0509L6E5AN
Outdoor unit		WH-WDG05LE5		WH-WDG07LE5		WH-WDG09LE5	
Tapping profile according EN16147		M	L	M	L	M	L
DHW tank ERP efficiency average / warm / cold <sup>2)</sup>	A+ to F	A+/A++/A	A+/A+/A	A+/A++/A	A+/A+/A	A+/A++/A	A+/A+/A
DHW tank ERP average climate η / COPdHW	η <sub>wh</sub> % / COPdHW	115/2,88	148/3,61	115/2,88	148/3,61	115/2,88	148/3,61
DHW tank ERP warm climate η / COPdHW	η <sub>wh</sub> % / COPdHW	134/3,35	160/4,00	134/3,35	160/4,00	134/3,35	160/4,00
DHW tank ERP cold climate η / COPdHW	η <sub>wh</sub> % / COPdHW	90/2,26	112/2,80	90/2,26	112/2,80	90/2,26	112/2,80

1) Check local regulations. 2) Scale from A+ to F. \*This product is designed to comply with the European drinking water standard (EU) 2020/2184. The lifespan of the product is not guaranteed in the case of the use of groundwater, such as spring water or well water, the use of tap water when salt or other impurities are contained, nor in areas of acidic water quality. Maintenance and warranty costs related to these cases are the customer's responsibility.

## Bi-bloc:

**Flexibility:** Flexible choice of DHW tank size.

**Control:** Optimised user interface and improved features (2 zone control, bivalent control).

**Connectivity:** Wi-Fi adapter included for smart control via Comfort Cloud App.

Indoor unit			WH-SDC0509L3E5	WH-SDC0509L6E5
Sound pressure	Heat / Cool	dB(A)	28/28	28/28
Dimension / Net weight	H x W x D	mm / kg	892 x 500 x 348 / 33	892 x 500 x 348 / 33
Water pipe connector	Room	Inch	R 1¼	R 1¼
A class pump	Number of speeds		Variable speed	Variable speed
	Input power (Min/Max)	W	30/145	30/145
Heating water flow (ΔT=5 K, 35 °C)		L/min	14,3	20,1
Water pipe connector (indoor / outdoor units)		Inch	1/1	1/1
Pipe length range standard / maximum		m	5/30	5/30
Elevation difference (in / out)		m	10	10
Electric backup heater		kW	3,00	6,00
Recommended fuse, supply 1 / 2 <sup>1)</sup>		A	25/16	25/30
Recommended minimum cable size, supply 1 / 2 <sup>1)</sup>		mm <sup>2</sup>	3x2,5/3x1,5	3x2,5/3x4,0

1) Check local regulations. \*This product is designed to comply with the European drinking water standard (EU) 2020/2184. The lifespan of the product is not guaranteed in the case of the use of groundwater, such as spring water or well water, the use of tap water when salt or other impurities are contained, nor in areas of acidic water quality. Maintenance and warranty costs related to these cases are the customer's responsibility.

Common accessories	
<b>CZ-RTW1</b>	Optional remote controller for 2 zone control. K and L Series
<b>CZ-N55P</b>	PCB for advanced functions
<b>PAW-A2W-RTWIRED</b>	Room thermostat
<b>PAW-A2W-RTWIREDLESS</b>	Wireless LCD room thermostat
<b>PAW-A2W-AFVLV-1</b>	1 antifreeze valve 1". It is required to order 2 valves per system

Bi-bloc accessories	
<b>PAW-TD20C1E5-1</b>	Tank 200 L - Stainless steel
<b>PAW-TD30C1E5-1</b>	Tank 300 L - Stainless steel
<b>PAW-TA20C1E5STD</b>	Tank 200 L - Enamelled
<b>PAW-TA30C1E5STD</b>	Tank 300 L - Enamelled
<b>PAW-3WYVLV-HW</b>	3 way valve for DHW tanks
<b>CZ-NV2</b>	3 way valve kit to fit inside the hydrokit. K and L Series
<b>PAW-BTANK50L-2</b>	Buffer tank 50 L

**NEW! Aquarea High Performance Hydraulic M Series outdoor units. Single phase - R290**

**Natural refrigerant R290 with GWP 0,02.**

**Energy efficiency:** A+++ in heating at 35 °C.

**Flexibility:** Hydronic connection between indoor and outdoor / Built-in magnetic water filter.

**Comfort:** Operation without backup heating at -25 °C / 75 °C water outlet temperature maximum at -15 °C outside temperature / 55 °C hot water even at -25 °C outside temperature.

NEW



Included

\*For All in One.

Combination table					Outdoor unit					
Indoor unit					Heating capacity					
	DHW tank	Backup heater capacity	Electrical anode		Single phase		Three phase			
					12,0 kW	16,0 kW	9,0 kW	12,0 kW	16,0 kW	
					WH-WDG12ME5	WH-WDG16ME5	WH-WDG09ME8	WH-WDG12ME8	WH-WDG16ME8	
Hydraulic All in One	1ph	120 L	3 kW	—	WH-ADC0916M3E51	✓	✓	—	—	—
		185 L	3 kW	—	WH-ADC0916M3E52	✓	✓	—	—	—
		185 L	3 kW	✓	WH-ADC0916M3E5AN2	✓	✓	—	—	—
		185 L	6 kW	—	WH-ADC0916M6E52	✓	✓	—	—	—
		260 L	3 kW	—	WH-ADC0916M3E53	✓	✓	—	—	—
	3ph	260 L	3 kW	✓	WH-ADC0916M3E5AN3	✓	✓	—	—	—
		260 L	6 kW	—	WH-ADC0916M6E53	✓	✓	—	—	—
		120 L	9 kW	—	WH-ADC0316M9E81	✓	✓	✓	✓	✓
		185 L	9 kW	—	WH-ADC0316M9E82	✓	✓	✓	✓	✓
		185 L	9 kW	✓	WH-ADC0316M9E8AN2	✓	✓	✓	✓	✓
Hydraulic Bi-bloc	1ph	260 L	9 kW	—	WH-ADC0316M9E83	✓	✓	✓	✓	✓
		260 L	9 kW	✓	WH-ADC0316M9E8AN3	✓	✓	✓	✓	✓
	3ph	—	3 kW	—	WH-SDC0916M3E5	✓	✓	—	—	—
		—	6 kW	—	WH-SDC0916M6E5	✓	✓	—	—	—
Control module	1ph	—	—	WH-CME5	✓	✓	—	—	—	
	3ph	—	—	WH-CME8	✓	✓	✓	✓	✓	
Remote controller with Wi-Fi adapter	—	—	—	CZ-RTW2TAW1C	✓	✓	✓	✓	✓	

Outdoor unit		WH-WDG12ME5	WH-WDG16ME5	WH-WDG09ME8	WH-WDG12ME8	WH-WDG16ME8
Heating capacity / COP (A +7 °C, W 35 °C)	kW / COP	12,00/4,88	16,00/4,65	9,00/5,10	12,00/4,88	16,00/4,65
Heating capacity / COP (A +7 °C, W 55 °C)	kW / COP	12,00/3,06	14,70/3,00	9,00/3,10	12,00/3,06	14,70/3,00
Heating capacity / COP (A +2 °C, W 35 °C)	kW / COP	12,00/3,46	13,00/3,30	9,00/3,81	12,00/3,46	13,00/3,30
Heating capacity / COP (A +2 °C, W 55 °C)	kW / COP	12,00/2,27	12,00/2,27	9,00/2,52	12,00/2,27	12,00/2,27
Heating capacity / COP (A -7 °C, W 35 °C)	kW / COP	10,50/3,00	11,70/2,63	9,00/3,16	10,50/3,00	11,70/2,63
Heating capacity / COP (A -7 °C, W 55 °C)	kW / COP	10,00/1,97	10,80/1,90	9,00/2,07	10,00/1,97	10,80/1,90
Cooling capacity / EER (A 35 °C, W 7 °C)	kW / EER	9,00/3,61	9,00/3,61	9,00/3,61	9,00/3,61	9,00/3,61
Cooling capacity / EER (A 35 °C, W 18 °C)	kW / EER	9,00/5,26	9,00/5,26	9,00/5,26	9,00/5,26	9,00/5,26
Heating average climate (W 35 °C / W 55 °C)	Seasonal energy efficiency	SCOP (η <sub>s</sub> %)	4,65/3,50(183/137)	4,58/3,58(180/140)	4,84/3,57(191/140)	4,65/3,58(183/140)
	Energy class <sup>1)</sup>	A+++ to D	A+++/A++	A+++/A++	A+++/A++	A+++/A++
Heating warm climate (W 35 °C / W 55 °C)	Seasonal energy efficiency	SCOP (η <sub>s</sub> %)	6,20/4,34(245/171)	6,20/4,34(245/171)	6,01/4,17(237/164)	6,20/4,34(245/171)
	Energy class <sup>1)</sup>	A+++ to D	A+++/A+++	A+++/A+++	A+++/A+++	A+++/A+++
Heating cold climate (W 35 °C / W 55 °C)	Seasonal energy efficiency	SCOP (η <sub>s</sub> %)	4,35/3,26(171/127)	4,30/3,26(169/127)	4,23/3,12(166/122)	4,35/3,26(171/127)
	Energy class <sup>1)</sup>	A+++ to D	A++/A++	A++/A++	A++/A+	A++/A++
Sound power <sup>2)</sup>	Heat	dB(A)	55	58	54	55
Dimension / Net weight	HxWxD	mm / kg	1520x1200x370/147	1520x1200x370/147	1520x1200x370/151	1520x1200x370/151
Pipe length range standard / maximum	m		5/30	5/30	5/30	5/30
Elevation difference (in / out)	m		30	30	30	30
A class pump	Number of speeds		Variable speed	Variable speed	Variable speed	Variable speed
	Input power (Min/Max)	W	30/175	30/175	30/175	30/175
Heating water flow (ΔT=5 K, 35 °C)	L/min		34,4	45,9	25,8	34,4
Refrigerant (R290) / CO <sub>2</sub> Eq. <sup>3)</sup>	kg / T		1,58/0,00003	1,58/0,00003	1,58/0,00003	1,58/0,00003
Operating range - outdoor ambient	Heat	°C	-25 ~ +35	-25 ~ +35	-25 ~ +35	-25 ~ +35
	Cool	°C	+10 ~ +43	+10 ~ +43	+10 ~ +43	+10 ~ +43
Water outlet	Heat <sup>4)</sup> / Cool	°C	25 ~ 75/5 ~ 20	25 ~ 75/5 ~ 20	25 ~ 75/5 ~ 20	25 ~ 75/5 ~ 20
Recommended fuse, supply <sup>5)</sup>	A		32	32	20	20
Recommended minimum cable size, supply <sup>5)</sup>	mm <sup>2</sup>		3x4,0	3x4,0	5x1,5	5x1,5

1) Scale from A+++ to D. 2) Sound power level in accordance to EN 12102 under conditions of the EN14825 (part load). 3) WH-WDG models are hermetically sealed. 4) Water outlet up to 75 °C above -15 °C outdoor. Between outdoor ambient -15 °C and -25 °C, the water outlet temperature gradually decreases from 75 °C to 55 °C. 5) Check local regulations. \*\*EER and COP calculation is based in accordance to EN 14511.



DHW A+: For All in One.

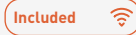

## Aquarea High Performance Hydraulic M Series indoor units. Single phase - R290

Natural refrigerant R290 with GWP 0,02.

**Control:** All control functions / 2 CN-CNT ports / Optional PCB for advanced functions.

**Connectivity:** Wi-Fi adapter included for smart control via Comfort Cloud App / Optional integration into BMS.

### All in One:

**Energy efficiency:** A+ in DHW / DHW up to 65 °C without heater / Stainless steel DHW tank with U-Vacua™.

**Flexibility:** Backup heater included / Built-in 10 L expansion vessel / 30 m maximum height difference between indoor and outdoor / Suitable for harsh-water installations (AN version).

Indoor unit		WH-ADC	0916M3E51	0316M9E81	0916M3E52	0916M6E52	0316M9E82	0916M3E53	0916M6E53	0316M9E83
Indoor unit with Electrical Anode		WH-ADC	—	—	0916M3E5AN2	—	0316M9E8AN2	0916M3E5AN3	—	0316M9E8AN3
Sound pressure	Heat / Cool	dB(A)	22/22	22/22	22/22	22/22	22/22	22/22	22/22	22/22
Dimension / Net weight	H x W x D	mm / kg	1293 x 599 x 602/73	1293 x 599 x 602/77	1642 x 599 x 602/88	1642 x 599 x 602/88	1642 x 599 x 602/89	2036 x 599 x 602/105	2036 x 599 x 602/105	2036 x 599 x 602/105
Water pipe connector	Room / Shower	Inch	1¼/¾	1¼/¾	1¼/¾	1¼/¾	1¼/¾	1¼/¾	1¼/¾	1¼/¾
Water volume		L	120	120	185	185	185	260	260	260
Maximum DHW temperature		°C	65	65	65	65	65	65	65	65
Material inside tank			Stainless steel	Stainless steel	Stainless steel	Stainless steel	Stainless steel	Stainless steel	Stainless steel	Stainless steel
Water pipe connector (indoor / outdoor units)		Inch	1¼/1¼	1¼/1¼	1¼/1¼	1¼/1¼	1¼/1¼	1¼/1¼	1¼/1¼	1¼/1¼
Electric backup heater		kW	3,00	9,00	3,00	6,00	9,00	3,00	6,00	9,00
Recommended fuse, supply <sup>1)</sup>		A	15/16	20	15/16	30	20	15/16	30	20
Recommended minimum cable size, supply <sup>1)</sup>		mm <sup>2</sup>	3x1,5	5x1,5	3x1,5	3x4,0	5x1,5	3x1,5	3x4,0	5x1,5
Connecting cable to the outdoor unit size		mm <sup>2</sup>	2x0,75	2x0,75	2x0,75	2x0,75	2x0,75	2x0,75	2x0,75	2x0,75

### Domestic Hot Water energy efficiency

Indoor unit	WH-	ADC0916M3E51	ADC0916M3E51	ADC0916M3E52	ADC0916M3E52	ADC0916M3E53	ADC0916M3E53
		—	—	ADC0916M3E5AN2	ADC0916M3E5AN2	ADC0916M3E5AN3	ADC0916M3E5AN3
Outdoor unit	WH-	WDG0916ME5	WDG12ME5	WDG12ME5	WDG12ME5	WDG12ME5	WDG12ME5
		WH-WDG12ME5	WH-WDG16ME5	WH-WDG12ME5	WH-WDG16ME5	WH-WDG12ME5	WH-WDG16ME5
Tapping profile according EN16147		M	M	L	L	XL	XL
DHW tank ERP efficiency average / warm / cold <sup>2)</sup>	A+ to F	A+/A+/A	A+/A+/A	A+/A+/A	A+/A+/A	A+/A+/A	A+/A+/A
DHW tank ERP average climate $\eta$ / COPdHW	$\eta_{wh}\%$ /COPdHW	100/2,51	96/2,40	120/3,00	115/2,87	124/3,10	114/2,85
DHW tank ERP warm climate $\eta$ / COPdHW	$\eta_{wh}\%$ /COPdHW	104/2,60	101/2,51	134/3,35	134/3,35	134/3,35	134/3,35
DHW tank ERP cold climate $\eta$ / COPdHW	$\eta_{wh}\%$ /COPdHW	73/1,82	70/1,75	88/2,20	84/2,10	94/2,35	84/2,10

### Domestic Hot Water energy efficiency

Indoor unit	WH-ADC	ADC0316M9E81	ADC0316M9E81	ADC0316M9E81	ADC0316M9E82	ADC0316M9E82
		—	—	—	WH-ADC0316M9E8AN2	WH-ADC0316M9E8AN2
Outdoor unit	WH-	WDG09ME8	WDG12ME8	WDG16ME8	WDG09ME8	WDG12ME8
		WH-WDG09ME8	WH-WDG12ME8	WH-WDG16ME8	WH-WDG09ME8	WH-WDG12ME8
Tapping profile according EN16147		M	M	M	L	L
DHW tank ERP efficiency average / warm / cold <sup>2)</sup>	A+ to F	A+/A+/A	A+/A+/A	A+/A+/A	A+/A+/A	A+/A+/A
DHW tank ERP average climate $\eta$ / COPdHW	$\eta_{wh}\%$ /COPdHW	100/2,51	100/2,51	96/2,40	120/3,00	120/3,00
DHW tank ERP warm climate $\eta$ / COPdHW	$\eta_{wh}\%$ /COPdHW	108/2,70	108/2,70	101/2,51	134/3,35	134/3,35
DHW tank ERP cold climate $\eta$ / COPdHW	$\eta_{wh}\%$ /COPdHW	73/1,82	73/1,82	70/1,75	88/2,20	88/2,20

### Domestic Hot Water energy efficiency

Indoor unit	WH-ADC	ADC0316M9E82	ADC0316M9E83	ADC0316M9E83	ADC0316M9E83
		WH-ADC0316M9E8AN2	WH-ADC0316M9E8AN3	WH-ADC0316M9E8AN3	WH-ADC0316M9E8AN3
Outdoor unit	WH-	WDG16ME8	WDG09ME8	WDG12ME8	WDG16ME8
		WH-WDG16ME8	WH-WDG09ME8	WH-WDG12ME8	WH-WDG16ME8
Tapping profile according EN16147		L	XL	XL	XL
DHW tank ERP efficiency average / warm / cold <sup>2)</sup>	A+ to F	A+/A+/A	A+/A+/A	A+/A+/A	A+/A+/A
DHW tank ERP average climate $\eta$ / COPdHW	$\eta_{wh}\%$ /COPdHW	115/2,87	124/3,10	124/3,10	114/2,85
DHW tank ERP warm climate $\eta$ / COPdHW	$\eta_{wh}\%$ /COPdHW	134/3,35	134/3,35	134/3,35	134/3,35
DHW tank ERP cold climate $\eta$ / COPdHW	$\eta_{wh}\%$ /COPdHW	84/2,10	94/2,35	94/2,35	84/2,10

1) Check local regulations. 2) Scale from A+ to F. Energy class A with 16 kW outdoor unit. \*Tentative data. \*\*This product is designed to comply with the European drinking water standard [EU] 2020/2184. The lifespan of the product is not guaranteed in the case of the use of groundwater, such as spring water or well water, the use of tap water when salt or other impurities are contained, nor in areas of acidic water quality. Maintenance and warranty costs related to these cases are the customer's responsibility.

## Aquarea High Performance Hydraulic M Series indoor units. Single phase - R290

Natural refrigerant R290 with GWP 0,02.

**Control:** All control functions / 2 CN-CNT ports / Optional PCB for advanced functions.

**Connectivity:** Wi-Fi adapter included for smart control via Comfort Cloud App / Optional integration into BMS.



Included 

### Bi-bloc:

**Flexibility:** Flexible choice of DHW tank size.

Indoor unit			WH-SDC0916M3E5	WH-SDC0916M6E5	WH-SDC0316M9E8
Sound pressure	Heat / Cool	dB(A)	22/22	22/22	22/22
Dimension / Net weight	H x W x D	mm / kg	892 x 500 x 348 / 28	892 x 500 x 348 / 28	892 x 500 x 348 / 29
Water pipe connector	Room	Inch	1¼	1¼	1¼
Water pipe connector (indoor / outdoor units)		Inch	1¼ / 1¼	1¼ / 1¼	1¼ / 1¼
Electric backup heater		kW	3,00	6,00	9,00
Recommended fuse, supply <sup>1)</sup>		A	15 / 16	30	20
Recommended minimum cable size, supply <sup>1)</sup>		mm <sup>2</sup>	3x1,5	3x4,0	5x1,5
Connecting cable to the outdoor unit size		mm <sup>2</sup>	2x0,75	2x0,75	2x0,75

<sup>1)</sup> Check local regulations. \*This product is designed to comply with the European drinking water standard (EU) 2020/2184. The lifespan of the product is not guaranteed in the case of the use of groundwater, such as spring water or well water, the use of tap water when salt or other impurities are contained, nor in areas of acidic water quality. Maintenance and warranty costs related to these cases are the customer's responsibility.

### Control module:

**Flexibility:** Simplified installation / Minimal interior space required / Supports third-party backup heater.

Indoor unit			WH-CME5	WH-CME8
Dimension / Net weight	H x W x D	mm / kg	454 x 520 x 116 / 7	454 x 520 x 116 / 7
Field supply electrical backup heater		kW	Up to 3 kW	Up to 9 kW
Recommended fuse, supply <sup>1)</sup>		A	16	30
Recommended minimum cable size, supply <sup>1)</sup>		mm <sup>2</sup>	3x1,5	3x4,0
Connecting cable to the outdoor unit size		mm <sup>2</sup>	2x0,75	2x0,75

<sup>1)</sup> Check local regulations.

Accessories	
<b>CZ-RTW2TAW1C</b>	Remote controller with Wi-Fi adapter (required for stand-alone outdoor units). M Series
<b>CZ-RTW2-1</b>	Optional remote controller for 2 zone control. M Series
<b>CZ-NS6P</b>	PCB for advanced functions. M Series All in One and Bi-bloc
<b>CZ-NS7P</b>	PCB for advanced functions. M Series control module
<b>PAW-A2W-RTWIRED</b>	Room thermostat
<b>PAW-A2W-RTWIRELESS</b>	Wireless LCD room thermostat
<b>PAW-A2W-AFVLV-1</b>	1 antifreeze valve 1". It is required to order 2 valves per system

Accessories	
<b>CZ-NV3</b>	3 way valve kit to fit inside the hydrokit. M Series
<b>PAW-TD20C1E5-1</b>	Tank 200 L - Stainless steel
<b>PAW-TD30C1E5-1</b>	Tank 300 L - Stainless steel
<b>PAW-TA20C1E5STD</b>	Tank 200 L - Enamelled
<b>PAW-TA30C1E5STD</b>	Tank 300 L - Enamelled
<b>PAW-3WYVLV-HW</b>	3 way valve for DHW tanks
<b>PAW-BTANK50L-2</b>	Buffer tank 50 L
<b>PAW-BTANK100L</b>	Buffer tank 100 L
<b>PAW-BTANKG200L</b>	Buffer tank 200 L
<b>PAW-BTANKG260L</b>	Buffer tank 260 L

NEW



Check all our certified heat pumps on:  
[www.heatpumpkeymark.com](http://www.heatpumpkeymark.com)



Optional



## NEW! Aquarea High Performance Mono-bloc J Series. Single phase - MDC - R32

**Energy efficiency:** A+++ in heating at 35 °C / "A" water pump with variable speed / Built-in flow meter.

**Flexibility:** Built-in magnetic water filter / Built-in 6 L expansion vessel.

**Comfort:** Operating range to -20 °C / 60 °C flow temperature / Cooling mode down to +10 °C.

**Control:** Additional functions with optional PCB (2 zone control, bivalent control, Smart Grid contact and more).

**Connectivity:** Optional Wi-Fi and BMS integration

Outdoor unit			WH-MDC05J3E5-1	WH-MDC07J3E5-1	WH-MDC09J3E5-1
Heating capacity / COP (A +7 °C, W 35 °C)		kW / COP	5,00/5,08	7,00/4,76	9,00/4,48
Heating capacity / COP (A +7 °C, W 55 °C)		kW / COP	5,00/3,01	7,00/2,82	8,95/2,78
Heating capacity / COP (A +2 °C, W 35 °C)		kW / COP	5,00/3,57	7,00/3,40	7,45/3,13
Heating capacity / COP (A +2 °C, W 55 °C)		kW / COP	5,00/2,27	6,30/2,16	7,00/2,12
Heating capacity / COP (A -7 °C, W 35 °C)		kW / COP	5,00/2,78	6,80/2,81	7,50/2,63
Heating capacity / COP (A -7 °C, W 55 °C)		kW / COP	5,00/1,85	6,30/1,86	7,00/1,80
Cooling capacity / EER (A 35 °C, W 7 °C)		kW / EER	5,00/3,31	7,00/3,06	9,00/2,71
Cooling capacity / EER (A 35 °C, W 18 °C)		kW / EER	5,00/5,05	7,00/4,73	9,00/4,25
Heating average climate (W 35 °C / W 55 °C)	Seasonal energy efficiency	SCOP (η <sub>s</sub> %)	5,12/3,63(202/142)	4,90/3,32(193/130)	4,90/3,32(193/130)
	Energy class		A+++/A++	A+++/A++	A+++/A++
Heating warm climate (W 35 °C / W 55 °C)	Seasonal energy efficiency	SCOP (η <sub>s</sub> %)	6,00/4,20(237/165)	5,75/4,07(227/160)	5,75/4,07(227/160)
	Energy class		A+++/A+++	A+++/A+++	A+++/A+++
Heating cold climate (W 35 °C / W 55 °C)	Seasonal energy efficiency	SCOP (η <sub>s</sub> %)	4,08/2,95(160/115)	4,18/2,98(164/116)	4,18/2,98(164/116)
	Energy class		A+++ to D	A++/A+	A++/A+
Sound power <sup>1)</sup>	Heat	dB(A)	59	59	59
Dimension	H x W x D	mm	865 x 1283 x 320	865 x 1283 x 320	865 x 1283 x 320
Net weight		kg	99	104	104
Refrigerant (R32) / CO <sub>2</sub> Eq. <sup>2)</sup>		kg / T	1,3/0,878	1,3/0,878	1,3/0,878
Water pipe connector		Inch	R 1½	R 1½	R 1½
Pump	Number of speeds		Variable speed	Variable speed	Variable speed
	Input power (Min/Max)	W	34/96	36/100	39/108
Heating water flow (ΔT=5 K, 35 °C)		L/min	14,3	20,1	25,8
Electric backup heater		kW	3,00	3,00	3,00
Input power	Heat	kW	0,985	1,47	2,01
	Cool	kW	1,51	2,29	3,32
Running and starting current	Heat	A	4,7	7,0	9,3
	Cool	A	7,0	10,5	14,7
Current 1		A	12	17	17
Current 2		A	13	13	13
Recommended fuse <sup>3)</sup>		A	30/15	30/15	30/16
Recommended minimum cable size, supply 1 / 2 <sup>3)</sup>		mm <sup>2</sup>	3x1,5/3x1,5	3x2,5/3x1,5	3x2,5/3x1,5
Operating range - outdoor ambient	Heat	°C	-20 ~ -35	-20 ~ -35	-20 ~ -35
	Cool	°C	+10 ~ +43	+10 ~ +43	+10 ~ +43
Water outlet	Heat	°C	20 ~ 60	20 ~ 60	20 ~ 60
	Cool	°C	5 ~ 20	5 ~ 20	5 ~ 20

1) Sound power in accordance to 811/2013, 813/2013 and EN 12102-1:2017 at +7 °C. 2) WH-MDC models are hermetically sealed. 3) Check local regulations. \*EER and COP calculation is based in accordance to EN 14511.

### Accessories

PAW-TD20C1E5-1	Tank 200 L - Stainless steel
PAW-TD30C1E5-1	Tank 300 L - Stainless steel
PAW-TA20C1E5STD	Tank 200 L - Enamelled
PAW-TA30C1E5STD	Tank 300 L - Enamelled
PAW-TD20B8E3-2	Combo Tank 185 L + 80 L - Enamelled
PAW-TD23B6E5	Combo Tank 230 L + 60 L - Stainless steel
PAW-3WYVLV-HW	3 way valve for DHW tanks
PAW-BTANK50L-2	Buffer tank 50 L

### Accessories

CZ-TAW1B	Optional Wi-Fi or WLAN adapter for smart control via Comfort Cloud App and/or remote maintenance via Aquarea Service Cloud
CZ-TAW1-CBL	10 m extension cable for CZ-TAW1B
PAW-A2W-AFVLV-1	1 antifreeze valve 1". It is required to order 2 valves per system
PAW-A2W-RTWIRED	Room thermostat
PAW-A2W-RTWIRELESS	Wireless LCD room thermostat



## Aquarea T-CAP All in One 185 L K Series. Single phase / Three phase · R32

**Comfort:** Constant capacity at 55 °C down to -15 °C / Operating range to -28 °C / 60 °C flow temperature at -10 °C.

**Flexibility:** 599 x 602 footprint / Built-in magnetic water filter.

**Energy efficiency:** A+++ heating at 35 °C / A+ DHW / "A"-rated variable-speed pump / Stainless steel DHW tank with U-Vacua™ / Built-in flow meter.

**Control:** Optimised user interface and improved features (2 zone control, bivalent control).

**Connectivity:** Optional Wi-Fi and BMS integration.

Check all our certified heat pumps on:  
[www.heatpumpkeymark.com](http://www.heatpumpkeymark.com)



Optional

Kit	Single phase (power to indoor)			Three phase (power to indoor)			
	KIT-AXC09K6E5	KIT-AXC12K6E5	KIT-AXC09K9E8	KIT-AXC12K9E8	KIT-AXC16K9E8		
Heating capacity / COP (A +7 °C, W 35 °C)	kW / COP	9,00/5,03	12,10/4,84	9,00/5,03	12,10/4,84	16,00/4,38	
Heating capacity / COP (A +7 °C, W 55 °C)	kW / COP	9,00/3,07	12,10/3,04	9,00/3,07	12,10/3,04	16,00/2,72	
Heating capacity / COP (A +2 °C, W 35 °C)	kW / COP	9,00/3,69	12,00/3,44	9,00/3,69	12,00/3,44	16,00/3,10	
Heating capacity / COP (A +2 °C, W 55 °C)	kW / COP	9,00/2,31	12,00/2,29	9,00/2,31	12,00/2,29	16,00/2,07	
Heating capacity / COP (A -7 °C, W 35 °C)	kW / COP	9,00/3,00	12,00/2,72	9,00/3,00	12,00/2,72	16,00/2,39	
Heating capacity / COP (A -7 °C, W 55 °C)	kW / COP	9,00/2,10	12,00/2,29	9,00/2,10	12,00/2,29	16,00/1,71	
Cooling capacity / EER (A 35 °C, W 7 °C)	kW / EER	8,80/3,11	10,70/2,68	8,80/3,11	10,70/2,68	13,40/2,64	
Cooling capacity / EER (A 35 °C, W 18 °C)	kW / EER	8,80/4,63	10,70/3,92	8,80/4,63	10,70/3,92	15,50/3,60	
Heating average climate (W 35 °C / W 55 °C)	Seasonal energy efficiency	SCOP (η <sub>s</sub> %)	4,96/3,57(195/140)	4,96/3,57(195/140)	4,96/3,57(195/140)	4,58/3,46(180/135)	4,46/3,31(176/129)
	Energy class <sup>1)</sup>	A+++ to D	A+++/A++	A+++/A++	A+++/A++	A+++/A++	A+++/A++
Heating warm climate (W 35 °C / W 55 °C)	Seasonal energy efficiency	SCOP (η <sub>s</sub> %)	6,47/4,34(256/171)	6,47/4,34(256/171)	6,47/4,34(256/171)	6,47/4,34(256/171)	5,88/4,09(232/160)
	Energy class <sup>1)</sup>	A+++ to D	A+++/A+++	A+++/A+++	A+++/A+++	A+++/A+++	A+++/A+++
Heating cold climate (W 35 °C / W 55 °C)	Seasonal energy efficiency	SCOP (η <sub>s</sub> %)	4,31/3,26(169/127)	4,31/3,26(169/127)	4,31/3,26(169/127)	4,31/3,26(169/127)	3,83/3,20(150/125)
	Energy class <sup>1)</sup>	A+++ to D	A++/A++	A++/A++	A++/A++	A++/A++	A++/A++
<b>Indoor unit</b>			<b>WH-ADC0912K6E5</b>	<b>WH-ADC0912K6E5</b>	<b>WH-ADC0912K9E8</b>	<b>WH-ADC0912K9E8</b>	<b>WH-ADC16K9E8</b>
Sound pressure	Heat / Cool	dB(A)	33/33	33/33	33/33	33/33	33/33
Dimension	HxWxD	mm	1642x599x602	1642x599x602	1642x599x602	1642x599x602	1642x599x602
Net weight		kg	101	101	102	102	103
Water pipe connector		Inch	R 1½	R 1½	R 1½	R 1½	R 1½
A class pump	Number of speeds		Variable speed	Variable speed	Variable speed	Variable speed	Variable speed
	Input power	W	145	145	145	145	173
Heating water flow (ΔT=5 K, 35 °C)		L/min	25,8	34,4	25,8	34,4	45,9
Water volume		L	185	185	185	185	185
Maximum DHW temperature		°C	65	65	65	65	65
Material inside tank			Stainless steel	Stainless steel	Stainless steel	Stainless steel	Stainless steel
Tapping profile according EN16147			L	L	L	L	L
DHW tank ERP efficiency average / warm / cold <sup>2)</sup>		A+ to F	A/A+/A	A/A+/A	A/A+/A	A/A+/A	A/A+/A
DHW tank ERP average climate η / COPdHW		η <sub>wh</sub> %/COPdHW	112/2,80	112/2,80	112/2,80	112/2,80	107/2,68
DHW tank ERP warm climate η / COPdHW		η <sub>wh</sub> %/COPdHW	132/3,30	132/3,30	132/3,30	132/3,30	128/3,20
DHW tank ERP cold climate η / COPdHW		η <sub>wh</sub> %/COPdHW	88/2,20	88/2,20	88/2,20	88/2,20	84/2,10
<b>Outdoor unit</b>			<b>WH-UXZ09KE5</b>	<b>WH-UXZ12KE5</b>	<b>WH-UXZ09KE8</b>	<b>WH-UXZ12KE8</b>	<b>WH-UXZ16KE8</b>
Sound power <sup>3)</sup>	Heat	dB(A)	65	65	65	65	65
Dimension / Net weight	HxWxD	mm / kg	1340x900x320/88	1340x900x320/88	1340x900x320/90	1340x900x320/90	1340x900x320/103
Refrigerant (R32) / CO <sub>2</sub> Eq.		kg / T	1,60/1,080	1,60/1,080	1,60/1,080	1,60/1,080	1,83/1,235
Piping diameter	Liquid / Gas	Inch (mm)	1/4(6,35)/1/2(12,70)	1/4(6,35)/1/2(12,70)	1/4(6,35)/1/2(12,70)	1/4(6,35)/1/2(12,70)	1/4(6,35)/1/2(12,70)
Pipe length range / Elevation difference (in / out)		m / m	3-30/20	3-30/20	3-30/20	3-30/20	3-30/20
Pre-charged pipe length / Additional gas amount		m / g/m	10/30	10/30	10/30	10/30	10/30
Operating range - outdoor ambient	Heat	°C	-28 ~ +35	-28 ~ +35	-28 ~ +35	-28 ~ +35	-28 ~ +35
	Cool	°C	+10 ~ +43	+10 ~ +43	+10 ~ +43	+10 ~ +43	+10 ~ +43
Water outlet <sup>4)</sup>	Heat / Cool	°C	20 ~ 60/5 ~ 20	20 ~ 60/5 ~ 20	20 ~ 60/5 ~ 20	20 ~ 60/5 ~ 20	20 ~ 60/5 ~ 20
<b>Electrical information</b>			<b>WH-ADC0912K6E5</b>	<b>WH-ADC0912K6E5</b>	<b>WH-ADC0912K9E8</b>	<b>WH-ADC0912K9E8</b>	<b>WH-ADC16K9E8</b>
Electric backup heater		kW	6,00	6,00	9,00	9,00	9,00
Recommended fuse <sup>5)</sup>		A	30/30	30/30	20/20	20/20	20/20
Recommended minimum cable size, supply 1 / 2 <sup>5)</sup>		mm <sup>2</sup>	3x4,0/3x4,0	3x4,0/3x4,0	5x1,5/5x1,5	5x1,5/5x1,5	5x2,5/5x1,5

1) Scale from A+++ to D. 2) Scale from A+ to F. 3) Sound power level in accordance to EN 12102 under conditions of the EN14825. 4) Between outdoor ambient -10 °C and -15 °C, the water outlet temperature gradually decreases from 60 °C to 55 °C. 5) Check local regulations. \*EER and COP calculation is based in accordance to EN 14511. \*\*This product is designed to comply with the European drinking water standard (EU) 2020/2184. The lifespan of the product is not guaranteed in the case of the use of groundwater, such as spring water or well water, the use of tap water when salt or other impurities are contained, nor in areas of acidic water quality. Maintenance and warranty costs related to these cases are the customer's responsibility.

### Accessories

<b>CZ-RTW1</b>	Optional remote controller for 2 zone control. K and L Series
<b>CZ-TAW1B</b>	Optional Wi-Fi or WLAN adapter for smart control via Comfort Cloud App and/or remote maintenance via Aquarea Service Cloud

### Accessories

<b>CZ-TAW1-CBL</b>	10 m extension cable for CZ-TAW1B
<b>CZ-NS5P</b>	PCB for advanced functions
<b>PAW-A2W-RTWIRED</b>	Room thermostat
<b>PAW-A2W-RTWIREDLESS</b>	Wireless LCD room thermostat



Check all our certified heat pumps on:  
www.heatpumpkeymark.com

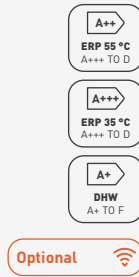

### Aquarea T-CAP All in One 185 L K Series. Single phase / Three phase with Electrical Anode - R32

**Comfort:** Constant capacity at 55 °C down to -15 °C / Operating range to -28 °C / 60 °C flow temperature at -10 °C.

**Flexibility:** Suitable for harsh-water installations / 599 x 602 footprint / Built-in magnetic water filter.

**Energy efficiency:** A+++ heating at 35 °C / A+ DHW / "A"-rated variable-speed pump / Stainless steel DHW tank with U-Vacua™ / Built-in flow meter.

**Control:** Optimised user interface and improved features (2 zone control, bivalent control).

**Connectivity:** Optional Wi-Fi and BMS integration.

Kit	Single phase [power to indoor]					Three phase [power to indoor]				
		KIT-AXC09K6E5AN	KIT-AXC12K6E5AN	KIT-AXC09K9E8AN	KIT-AXC12K9E8AN	KIT-AXC16K9E8AN				
Heating capacity / COP (A +7 °C, W 35 °C)	kW / COP	9,00/5,03	12,10/4,84	9,00/5,03	12,10/4,84	16,00/4,38				
Heating capacity / COP (A +7 °C, W 55 °C)	kW / COP	9,00/3,07	12,10/3,04	9,00/3,07	12,10/3,04	16,00/2,72				
Heating capacity / COP (A +2 °C, W 35 °C)	kW / COP	9,00/3,69	12,00/3,44	9,00/3,69	12,00/3,44	16,00/3,10				
Heating capacity / COP (A +2 °C, W 55 °C)	kW / COP	9,00/2,31	12,00/2,29	9,00/2,31	12,00/2,29	16,00/2,07				
Heating capacity / COP (A -7 °C, W 35 °C)	kW / COP	9,00/3,00	12,00/2,72	9,00/3,00	12,00/2,72	16,00/2,39				
Heating capacity / COP (A -7 °C, W 55 °C)	kW / COP	9,00/2,10	12,00/2,29	9,00/2,10	12,00/2,29	16,00/1,71				
Cooling capacity / EER (A 35 °C, W 7 °C)	kW / EER	8,80/3,11	10,70/2,68	8,80/3,11	10,70/2,68	13,40/2,64				
Cooling capacity / EER (A 35 °C, W 18 °C)	kW / EER	8,80/4,63	10,70/3,92	8,80/4,63	10,70/3,92	15,50/3,60				
Heating average climate (W 35 °C / W 55 °C)	Seasonal energy efficiency	SCOP (η <sub>s</sub> %)	4,96/3,57(195/140)	4,96/3,57(195/140)	4,96/3,57(195/140)	4,58/3,46(180/135)	4,46/3,31(176/129)			
	Energy class <sup>1)</sup>		A+++ to D	A+++/A++	A+++/A++	A+++/A++	A+++/A++			
Heating warm climate (W 35 °C / W 55 °C)	Seasonal energy efficiency	SCOP (η <sub>s</sub> %)	6,47/4,34(256/171)	6,47/4,34(256/171)	6,47/4,34(256/171)	6,47/4,34(256/171)	5,88/4,09(232/160)			
	Energy class <sup>1)</sup>		A+++ to D	A+++/A+++	A+++/A+++	A+++/A+++	A+++/A+++			
Heating cold climate (W 35 °C / W 55 °C)	Seasonal energy efficiency	SCOP (η <sub>s</sub> %)	4,31/3,26(169/127)	4,31/3,26(169/127)	4,31/3,26(169/127)	4,31/3,26(169/127)	3,83/3,20(150/125)			
	Energy class <sup>1)</sup>		A+++ to D	A++/A++	A++/A++	A++/A++	A++/A++			
<b>Indoor unit</b>		<b>WH-</b>	<b>ADC0912K6E5AN</b>	<b>ADC0912K6E5AN</b>	<b>ADC0912K9E8AN</b>	<b>ADC0912K9E8AN</b>	<b>ADC16K9E8AN</b>			
Sound pressure	Heat / Cool	dB(A)	33/33	33/33	33/33	33/33	33/33			
Dimension	H x W x D	mm	1642 x 599 x 602	1642 x 599 x 602	1642 x 599 x 602	1642 x 599 x 602	1642 x 599 x 602			
Net weight		kg	101	101	102	102	103			
Water pipe connector		Inch	R 1 1/4	R 1 1/4	R 1 1/4	R 1 1/4	R 1 1/4			
A class pump	Number of speeds		Variable speed	Variable speed	Variable speed	Variable speed	Variable speed			
	Input power	W	145	145	145	145	173			
Heating water flow (ΔT=5 K, 35 °C)		L/min	25,8	34,4	25,8	34,4	45,9			
Water volume		L	185	185	185	185	185			
Maximum DHW temperature		°C	65	65	65	65	65			
Material inside tank			Stainless steel	Stainless steel	Stainless steel	Stainless steel	Stainless steel			
Tapping profile according EN16147			L	L	L	L	L			
DHW tank ERP efficiency average / warm / cold <sup>2)</sup>		A+ to F	A/A+/A	A/A+/A	A/A+/A	A/A+/A	A/A+/A			
DHW tank ERP average climate η / COPdHW	η <sub>wh</sub> % / COPdHW		112/2,80	112/2,80	112/2,80	112/2,80	107/2,68			
DHW tank ERP warm climate η / COPdHW	η <sub>wh</sub> % / COPdHW		132/3,30	132/3,30	132/3,30	132/3,30	128/3,20			
DHW tank ERP cold climate η / COPdHW	η <sub>wh</sub> % / COPdHW		88/2,20	88/2,20	88/2,20	88/2,20	84/2,10			
<b>Outdoor unit</b>		<b>WH-</b>	<b>UXZ09KE5</b>	<b>UXZ12KE5</b>	<b>UXZ09KE8</b>	<b>UXZ12KE8</b>	<b>UXZ16KE8</b>			
Sound power <sup>3)</sup>	Heat	dB(A)	65	65	65	65	65			
Dimension / Net weight	H x W x D	mm / kg	1340 x 900 x 320/88	1340 x 900 x 320/88	1340 x 900 x 320/90	1340 x 900 x 320/90	1340 x 900 x 320/103			
Refrigerant (R32) / CO <sub>2</sub> Eq.		kg / T	1,60/1,080	1,60/1,080	1,60/1,080	1,60/1,080	1,83/1,235			
Piping diameter	Liquid / Gas	Inch (mm)	1/4(6,35)/1/2(12,70)	1/4(6,35)/1/2(12,70)	1/4(6,35)/1/2(12,70)	1/4(6,35)/1/2(12,70)	1/4(6,35)/1/2(12,70)			
Pipe length range / Elevation difference (in / out)		m / m	3~30/20	3~30/20	3~30/20	3~30/20	3~30/20			
Pre-charged pipe length / Additional gas amount		m / g/m	10/30	10/30	10/30	10/30	10/30			
Operating range - outdoor ambient	Heat	°C	-28~+35	-28~+35	-28~+35	-28~+35	-28~+35			
	Cool	°C	+10~+43	+10~+43	+10~+43	+10~+43	+10~+43			
Water outlet <sup>4)</sup>	Heat / Cool	°C	20~60/5~20	20~60/5~20	20~60/5~20	20~60/5~20	20~60/5~20			
<b>Electrical information</b>		<b>WH-</b>	<b>ADC0912K6E5AN</b>	<b>ADC0912K6E5AN</b>	<b>ADC0912K9E8AN</b>	<b>ADC0912K9E8AN</b>	<b>ADC16K9E8AN</b>			
Electric backup heater		kW	6,00	6,00	9,00	9,00	9,00			
Recommended fuse <sup>5)</sup>		A	30/30	30/30	20/20	20/20	20/20			
Recommended minimum cable size, supply 1 / 2 <sup>5)</sup>		mm <sup>2</sup>	3x4,0/3x4,0	3x4,0/3x4,0	5x1,5/5x1,5	5x1,5/5x1,5	5x2,5/5x1,5			

1) Scale from A+++ to D. 2) Scale from A+ to F. 3) Sound power level in accordance to EN 12102 under conditions of the EN14825. 4) Between outdoor ambient -10 °C and -15 °C, the water outlet temperature gradually decreases from 60 °C to 55 °C. 5) Check local regulations. \*EER and COP calculation is based in accordance to EN 14511. \*\*This product is designed to comply with the European drinking water standard (EU) 2020/2184. The lifespan of the product is not guaranteed in the case of the use of groundwater, such as spring water or well water, the use of tap water when salt or other impurities are contained, nor in areas of acidic water quality. Maintenance and warranty costs related to these cases are the customer's responsibility.

Accessories	
<b>CZ-RTW1</b>	Optional remote controller for 2 zone control. K and L Series
<b>CZ-TAW1B</b>	Optional Wi-Fi or WLAN adapter for smart control via Comfort Cloud App and/or remote maintenance via Aquarea Service Cloud

Accessories	
<b>CZ-TAW1-CBL</b>	10 m extension cable for CZ-TAW1B
<b>CZ-NS5P</b>	PCB for advanced functions
<b>PAW-A2W-RTWIRED</b>	Room thermostat
<b>PAW-A2W-RTWIREDLESS</b>	Wireless LCD room thermostat



## Aquarea T-CAP All in One 260 L K Series. Single phase / Three phase · R32

**Comfort:** Constant capacity at 55 °C down to -15 °C / Operating range to -28 °C / 60 °C flow temperature at -10 °C.

**Flexibility:** 599 x 602 footprint / Built-in magnetic water filter.

**Energy efficiency:** A+++ heating at 35 °C / A+ DHW / "A"-rated variable-speed pump / Stainless steel DHW tank with U-Vacua™ / Built-in flow meter.

**Control:** Optimised user interface and improved features (2 zone control, bivalent control).

**Connectivity:** Optional Wi-Fi and BMS integration.



Kit	Single phase (power to indoor)					Three phase (power to indoor)				
		KIT-AXC09K6E53	KIT-AXC12K6E53	KIT-AXC09K9E83	KIT-AXC12K9E83	KIT-AXC16K9E83				
Heating capacity / COP (A +7 °C, W 35 °C)	kW / COP	9,00/5,03	12,10/4,84	9,00/5,03	12,10/4,84	16,00/4,38				
Heating capacity / COP (A +7 °C, W 55 °C)	kW / COP	9,00/3,07	12,10/3,04	9,00/3,07	12,10/3,04	16,00/2,72				
Heating capacity / COP (A +2 °C, W 35 °C)	kW / COP	9,00/3,69	12,00/3,44	9,00/3,69	12,00/3,44	16,00/3,10				
Heating capacity / COP (A +2 °C, W 55 °C)	kW / COP	9,00/2,31	12,00/2,29	9,00/2,31	12,00/2,29	16,00/2,07				
Heating capacity / COP (A -7 °C, W 35 °C)	kW / COP	9,00/3,00	12,00/2,72	9,00/3,00	12,00/2,72	16,00/2,39				
Heating capacity / COP (A -7 °C, W 55 °C)	kW / COP	9,00/2,10	12,00/2,29	9,00/2,10	12,00/2,29	16,00/1,71				
Cooling capacity / EER (A 35 °C, W 7 °C)	kW / EER	8,80/3,11	10,70/2,68	8,80/3,11	10,70/2,68	13,40/2,64				
Cooling capacity / EER (A 35 °C, W 18 °C)	kW / EER	8,80/4,63	10,70/3,92	8,80/4,63	10,70/3,92	15,50/3,60				
Heating average climate (W 35 °C / W 55 °C)	Seasonal energy efficiency	SCOP (η <sub>s</sub> %)	4,96/3,57(195/140)	4,96/3,57(195/140)	4,96/3,57(195/140)	4,58/3,46(180/135)	4,46/3,31(176/129)			
	Energy class <sup>1)</sup>	A+++ to D	A+++/A++	A+++/A++	A+++/A++	A+++/A++	A+++/A++			
Heating warm climate (W 35 °C / W 55 °C)	Seasonal energy efficiency	SCOP (η <sub>s</sub> %)	6,47/4,34(256/171)	6,47/4,34(256/171)	6,47/4,34(256/171)	6,47/4,34(256/171)	5,88/4,09(232/160)			
	Energy class <sup>1)</sup>	A+++ to D	A+++/A+++	A+++/A+++	A+++/A+++	A+++/A+++	A+++/A+++			
Heating cold climate (W 35 °C / W 55 °C)	Seasonal energy efficiency	SCOP (η <sub>s</sub> %)	4,31/3,26(169/127)	4,31/3,26(169/127)	4,31/3,26(169/127)	4,31/3,26(169/127)	3,83/3,20(150/125)			
	Energy class <sup>1)</sup>	A+++ to D	A++/A++	A++/A++	A++/A++	A++/A++	A++/A++			
<b>Indoor unit</b>			<b>WH-ADC0912K6E53</b>	<b>WH-ADC0912K6E53</b>	<b>WH-ADC0912K9E83</b>	<b>WH-ADC0912K9E83</b>	<b>WH-ADC16K9E83</b>			
Sound pressure	Heat / Cool	dB(A)	33/33	33/33	33/33	33/33	33/33			
Dimension	HxWxD	mm	2036x599x602	2036x599x602	2036x599x602	2036x599x602	2036x599x602			
Net weight		kg	119	119	119	119	120			
Water pipe connector		Inch	R 1½	R 1½	R 1½	R 1½	R 1½			
A class pump	Number of speeds		Variable speed	Variable speed	Variable speed	Variable speed	Variable speed			
	Input power	W	145	145	145	145	145			
Heating water flow (ΔT=5 K, 35 °C)		L/min	25,8	34,4	25,8	34,4	45,9			
Water volume		L	260	260	260	260	260			
Maximum DHW temperature		°C	65	65	65	65	65			
Material inside tank			Stainless steel	Stainless steel	Stainless steel	Stainless steel	Stainless steel			
Tapping profile according EN16147			XL	XL	XL	XL	XL			
DHW tank ERP efficiency average / warm / cold <sup>2)</sup>		A+ to F	A+/A+/A	A+/A+/A	A+/A+/A	A+/A+/A	A+/A+/A			
DHW tank ERP average climate η / COPdHW	η <sub>wh</sub> %/COPdHW		123/3,08	123/3,08	123/3,08	123/3,08	98/2,45			
DHW tank ERP warm climate η / COPdHW	η <sub>wh</sub> %/COPdHW		134/3,35	134/3,35	134/3,35	134/3,35	123/3,08			
DHW tank ERP cold climate η / COPdHW	η <sub>wh</sub> %/COPdHW		94/2,35	94/2,35	94/2,35	94/2,35	80/2,00			
<b>Outdoor unit</b>			<b>WH-UXZ09KE5</b>	<b>WH-UXZ12KE5</b>	<b>WH-UXZ09KE8</b>	<b>WH-UXZ12KE8</b>	<b>WH-UXZ16KE8</b>			
Sound power <sup>3)</sup>	Heat	dB(A)	65	65	65	65	65			
Dimension / Net weight	HxWxD	mm / kg	1340x900x320/88	1340x900x320/88	1340x900x320/90	1340x900x320/90	1340x900x320/103			
Refrigerant (R32) / CO <sub>2</sub> Eq.		kg / T	1,60/1,080	1,60/1,080	1,60/1,080	1,60/1,080	1,83/1,235			
Piping diameter	Liquid / Gas	Inch (mm)	1/4(6,35)/1/2(12,70)	1/4(6,35)/1/2(12,70)	1/4(6,35)/1/2(12,70)	1/4(6,35)/1/2(12,70)	1/4(6,35)/1/2(12,70)			
Pipe length range / Elevation difference (in / out)		m / m	3-30/20	3-30/20	3-30/20	3-30/20	3-30/20			
Pre-charged pipe length / Additional gas amount		m / g/m	10/30	10/30	10/30	10/30	10/30			
Operating range - outdoor ambient	Heat	°C	-28 ~ +35	-28 ~ +35	-28 ~ +35	-28 ~ +35	-28 ~ +35			
	Cool	°C	+10 ~ +43	+10 ~ +43	+10 ~ +43	+10 ~ +43	+10 ~ +43			
Water outlet <sup>4)</sup>	Heat / Cool	°C	20 ~ 60/5 ~ 20	20 ~ 60/5 ~ 20	20 ~ 60/5 ~ 20	20 ~ 60/5 ~ 20	20 ~ 60/5 ~ 20			
<b>Electrical information</b>			<b>WH-ADC0912K6E53</b>	<b>WH-ADC0912K6E53</b>	<b>WH-ADC0912K9E83</b>	<b>WH-ADC0912K9E83</b>	<b>WH-ADC16K9E83</b>			
Electric backup heater		kW	6,00	6,00	9,00	9,00	9,00			
Recommended fuse <sup>5)</sup>		A	30/30	30/30	20/20	20/20	20/20			
Recommended minimum cable size, supply 1 / 2 <sup>5)</sup>		mm <sup>2</sup>	3x4,0/3x4,0	3x4,0/3x4,0	5x1,5/5x1,5	5x1,5/5x1,5	5x2,5/5x1,5			

1) Scale from A+++ to D. 2) Scale from A+ to F. 3) Sound power level in accordance to EN 12102 under conditions of the EN14825. 4) Between outdoor ambient -10 °C and -15 °C, the water outlet temperature gradually decreases from 60 °C to 55 °C. 5) Check local regulations. \*EER and COP calculation is based in accordance to EN 14511. \*\*This product is designed to comply with the European drinking water standard (EU) 2020/2184. The lifespan of the product is not guaranteed in the case of the use of groundwater, such as spring water or well water, the use of tap water when salt or other impurities are contained, nor in areas of acidic water quality. Maintenance and warranty costs related to these cases are the customer's responsibility.

### Accessories

<b>CZ-RTW1</b>	Optional remote controller for 2 zone control. K and L Series
<b>CZ-TAW1B</b>	Optional Wi-Fi or WLAN adapter for smart control via Comfort Cloud App and/or remote maintenance via Aquarea Service Cloud

### Accessories

<b>CZ-TAW1-CBL</b>	10 m extension cable for CZ-TAW1B
<b>CZ-NS5P</b>	PCB for advanced functions
<b>PAW-A2W-RTWIRED</b>	Room thermostat
<b>PAW-A2W-RTWIREDLESS</b>	Wireless LCD room thermostat



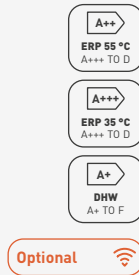

**Aqueara T-CAP All in One 260 L K Series. Single phase / Three phase with Electrical Anode - R32**

**Comfort:** Constant capacity at 55 °C down to -15 °C / Operating range to -28 °C / 60 °C flow temperature at -10 °C.

**Flexibility:** Suitable for harsh-water installations / 599 x 602 footprint / Built-in magnetic water filter.

**Energy efficiency:** A+++ heating at 35 °C / A+ DHW / "A"-rated variable-speed pump / Stainless steel DHW tank with U-Vacua™ / Built-in flow meter.

**Control:** Optimised user interface and improved features (2 zone control, bivalent control).

**Connectivity:** Optional Wi-Fi and BMS integration.

Kit	Single phase [power to indoor]					Three phase [power to indoor]					
		KIT-AXC09K6E5AN3	KIT-AXC12K6E5AN3	KIT-AXC09K9E8AN3	KIT-AXC12K9E8AN3	KIT-AXC16K9E8AN3					
Heating capacity / COP (A +7 °C, W 35 °C)	kW / COP	9,00/5,03	12,10/4,84	9,00/5,03	12,10/4,84	16,00/4,38					
Heating capacity / COP (A +7 °C, W 55 °C)	kW / COP	9,00/3,07	12,10/3,04	9,00/3,07	12,10/3,04	16,00/2,72					
Heating capacity / COP (A +2 °C, W 35 °C)	kW / COP	9,00/3,69	12,00/3,44	9,00/3,69	12,00/3,44	16,00/3,10					
Heating capacity / COP (A +2 °C, W 55 °C)	kW / COP	9,00/2,31	12,00/2,29	9,00/2,31	12,00/2,29	16,00/2,07					
Heating capacity / COP (A -7 °C, W 35 °C)	kW / COP	9,00/3,00	12,00/2,72	9,00/3,00	12,00/2,72	16,00/2,39					
Heating capacity / COP (A -7 °C, W 55 °C)	kW / COP	9,00/2,10	12,00/2,29	9,00/2,10	12,00/2,29	16,00/1,71					
Cooling capacity / EER (A 35 °C, W 7 °C)	kW / EER	8,80/3,11	10,70/2,68	8,80/3,11	10,70/2,68	13,40/2,64					
Cooling capacity / EER (A 35 °C, W 18 °C)	kW / EER	8,80/4,63	10,70/3,92	8,80/4,63	10,70/3,92	15,50/3,60					
Heating average climate (W 35 °C / W 55 °C)	Seasonal energy efficiency	SCOP (η <sub>s</sub> %)	4,96/3,57(195/140)	4,96/3,57(195/140)	4,96/3,57(195/140)	4,58/3,46(180/135)	4,46/3,31(176/129)				
	Energy class <sup>1)</sup>		A+++ to D	A+++/A++	A+++/A++	A+++/A++	A+++/A++				
Heating warm climate (W 35 °C / W 55 °C)	Seasonal energy efficiency	SCOP (η <sub>s</sub> %)	6,47/4,34(256/171)	6,47/4,34(256/171)	6,47/4,34(256/171)	6,47/4,34(256/171)	5,88/4,09(232/160)				
	Energy class <sup>1)</sup>		A+++ to D	A+++/A+++	A+++/A+++	A+++/A+++	A+++/A+++				
Heating cold climate (W 35 °C / W 55 °C)	Seasonal energy efficiency	SCOP (η <sub>s</sub> %)	4,31/3,26(169/127)	4,31/3,26(169/127)	4,31/3,26(169/127)	4,31/3,26(169/127)	3,83/3,20(150/125)				
	Energy class <sup>1)</sup>		A+++ to D	A++/A++	A++/A++	A++/A++	A++/A++				
<b>Indoor unit</b>		<b>WH-</b>	<b>ADC0912K6E5AN3</b>	<b>ADC0912K6E5AN3</b>	<b>ADC0912K9E8AN3</b>	<b>ADC0912K9E8AN3</b>	<b>ADC16K9E8AN3</b>				
Sound pressure	Heat / Cool	dB(A)	33/33	33/33	33/33	33/33	33/33				
Dimension	H x W x D	mm	2036 x 599 x 602	2036 x 599 x 602	2036 x 599 x 602	2036 x 599 x 602	2036 x 599 x 602				
Net weight		kg	119	119	119	119	120				
Water pipe connector		Inch	R 1 1/4	R 1 1/4	R 1 1/4	R 1 1/4	R 1 1/4				
A class pump	Number of speeds		Variable speed	Variable speed	Variable speed	Variable speed	Variable speed				
	Input power	W	145	145	145	145	145				
Heating water flow (ΔT=5 K, 35 °C)		L/min	25,8	34,4	25,8	34,4	45,9				
Water volume		L	260	260	260	260	260				
Maximum DHW temperature		°C	65	65	65	65	65				
Material inside tank			Stainless steel	Stainless steel	Stainless steel	Stainless steel	Stainless steel				
Tapping profile according EN16147			XL	XL	XL	XL	XL				
DHW tank ERP efficiency average / warm / cold <sup>2)</sup>		A+ to F	A+/A+/A	A+/A+/A	A+/A+/A	A+/A+/A	A+/A+/A				
DHW tank ERP average climate η / COPdHW		η <sub>wh</sub> % / COPdHW	123/3,08	123/3,08	123/3,08	123/3,08	98/2,45				
DHW tank ERP warm climate η / COPdHW		η <sub>wh</sub> % / COPdHW	134/3,35	134/3,35	134/3,35	134/3,35	123/3,08				
DHW tank ERP cold climate η / COPdHW		η <sub>wh</sub> % / COPdHW	94/2,35	94/2,35	94/2,35	94/2,35	80/2,00				
<b>Outdoor unit</b>		<b>WH-UXZ09KE5</b>	<b>WH-UXZ12KE5</b>	<b>WH-UXZ09KE8</b>	<b>WH-UXZ12KE8</b>	<b>WH-UXZ16KE8</b>					
Sound power <sup>3)</sup>	Heat	dB(A)	65	65	65	65	65				
Dimension / Net weight	H x W x D	mm / kg	1340 x 900 x 320/88	1340 x 900 x 320/88	1340 x 900 x 320/90	1340 x 900 x 320/90	1340 x 900 x 320/103				
Refrigerant (R32) / CO <sub>2</sub> Eq.		kg / T	1,60/1,080	1,60/1,080	1,60/1,080	1,60/1,080	1,83/1,235				
Piping diameter	Liquid / Gas	Inch (mm)	1/4(6,35)/1/2(12,70)	1/4(6,35)/1/2(12,70)	1/4(6,35)/1/2(12,70)	1/4(6,35)/1/2(12,70)	1/4(6,35)/1/2(12,70)				
Pipe length range / Elevation difference (in / out)		m / m	3~30/20	3~30/20	3~30/20	3~30/20	3~30/20				
Pre-charged pipe length / Additional gas amount		m / g/m	10/30	10/30	10/30	10/30	10/30				
Operating range - outdoor ambient	Heat	°C	-28~+35	-28~+35	-28~+35	-28~+35	-28~+35				
	Cool	°C	+10~+43	+10~+43	+10~+43	+10~+43	+10~+43				
Water outlet <sup>4)</sup>	Heat / Cool	°C	20~60/5~20	20~60/5~20	20~60/5~20	20~60/5~20	20~60/5~20				
<b>Electrical information</b>		<b>WH-</b>	<b>ADC0912K6E5AN3</b>	<b>ADC0912K6E5AN3</b>	<b>ADC0912K9E8AN3</b>	<b>ADC0912K9E8AN3</b>	<b>ADC16K9E8AN3</b>				
Electric backup heater		kW	6,00	6,00	9,00	9,00	9,00				
Recommended fuse <sup>5)</sup>		A	30/30	30/30	20/20	20/20	20/20				
Recommended minimum cable size, supply 1 / 2 <sup>5)</sup>		mm <sup>2</sup>	3x4,0/3x4,0	3x4,0/3x4,0	5x1,5/5x1,5	5x1,5/5x1,5	5x2,5/5x1,5				

1) Scale from A+++ to D. 2) Scale from A+ to F. 3) Sound power level in accordance to EN 12102 under conditions of the EN14825. 4) Between outdoor ambient -10 °C and -15 °C, the water outlet temperature gradually decreases from 60 °C to 55 °C. 5) Check local regulations. \*EER and COP calculation is based in accordance to EN 14511. \*\*This product is designed to comply with the European drinking water standard (EU) 2020/2184. The lifespan of the product is not guaranteed in the case of the use of groundwater, such as spring water or well water, the use of tap water when salt or other impurities are contained, nor in areas of acidic water quality. Maintenance and warranty costs related to these cases are the customer's responsibility.

Accessories	
<b>CZ-RTW1</b>	Optional remote controller for 2 zone control. K and L Series
<b>CZ-TAW1B</b>	Optional Wi-Fi or WLAN adapter for smart control via Comfort Cloud App and/or remote maintenance via Aqueara Service Cloud

Accessories	
<b>CZ-TAW1-CBL</b>	10 m extension cable for CZ-TAW1B
<b>CZ-NS5P</b>	PCB for advanced functions
<b>PAW-A2W-RTWIRED</b>	Room thermostat
<b>PAW-A2W-RTWIREDLESS</b>	Wireless LCD room thermostat



## NEW! Aquarea T-CAP All in One 185 L K Series. Three phase. Super Quiet outdoor unit - R32

**Comfort:** Super Quiet outdoor unit (-7 dB(A)) / Constant capacity at 55 °C down to -15 °C / Operating range to -28 °C / 60 °C flow temperature at -10 °C

**Flexibility:** 599 x 602 footprint / Built-in magnetic water filter.

**Energy efficiency:** A+++ heating at 35 °C / A+ DHW / "A"-rated variable-speed pump / Stainless steel DHW tank with U-Vacua™ / Built-in flow meter

**Control:** Optimised user interface and improved features (2 zone control, bivalent control).

**Connectivity:** Optional Wi-Fi and BMS integration.

NEW

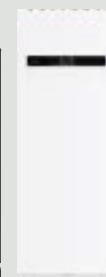

Optional

Three phase (power to indoor)

Kit			KIT-AQC09K9E8	KIT-AQC12K9E8	KIT-AQC16K9E8
Heating capacity / COP (A +7 °C, W 35 °C)	kW / COP		9,00/5,03	12,10/4,84	16,00/4,38
Heating capacity / COP (A +7 °C, W 55 °C)	kW / COP		9,00/3,07	12,10/3,04	16,00/2,72
Heating capacity / COP (A +2 °C, W 35 °C)	kW / COP		9,00/3,69	12,00/3,44	16,00/3,10
Heating capacity / COP (A +2 °C, W 55 °C)	kW / COP		9,00/2,31	12,00/2,29	16,00/2,07
Heating capacity / COP (A -7 °C, W 35 °C)	kW / COP		9,00/3,00	12,00/2,72	16,00/2,39
Heating capacity / COP (A -7 °C, W 55 °C)	kW / COP		9,00/2,10	12,00/2,20	16,00/1,71
Cooling capacity / EER (A 35 °C, W 7 °C)	kW / EER		8,80/3,11	10,70/2,68	13,40/2,64
Cooling capacity / EER (A 35 °C, W 18 °C)	kW / EER		8,80/4,63	10,70/3,92	15,50/3,60
Heating average climate (W 35 °C / W 55 °C)	Seasonal energy efficiency	SCOP (η <sub>s</sub> %)	4,44 / 3,20 (175 / 125)	4,44 / 3,34 (175 / 131)	4,46 / 3,31 (176 / 129)
	Energy class <sup>1)</sup>		A+++ / A++	A+++ / A++	A+++ / A++
Heating warm climate (W 35 °C / W 55 °C)	Seasonal energy efficiency	SCOP (η <sub>s</sub> %)	6,47 / 4,34 (256 / 171)	6,47 / 4,34 (256 / 171)	5,88 / 4,09 (232 / 160)
	Energy class <sup>1)</sup>		A+++ / A+++	A+++ / A+++	A+++ / A+++
Heating cold climate (W 35 °C / W 55 °C)	Seasonal energy efficiency	SCOP (η <sub>s</sub> %)	4,31 / 3,26 (169 / 127)	4,31 / 3,26 (169 / 127)	3,83 / 3,20 (150 / 125)
	Energy class <sup>1)</sup>		A++ / A++	A++ / A++	A++ / A++
<b>Indoor unit</b>			<b>WH-ADC0912K9E8</b>	<b>WH-ADC0912K9E8</b>	<b>WH-ADC16K9E8</b>
Sound pressure	Heat / Cool	dB(A)	33/33	33/33	33/33
Dimension	H x W x D	mm	1642 x 599 x 602	1642 x 599 x 602	1642 x 599 x 602
Net weight		kg	102	102	103
Water pipe connector		Inch	R 1/4	R 1/4	R 1/4
A class pump	Number of speeds		Variable speed	Variable speed	Variable speed
	Input power	W	145	145	173
Heating water flow (ΔT=5 K, 35 °C)		L/min	25,8	34,4	45,9
Water volume		L	185	185	185
Maximum DHW temperature		°C	65	65	65
Material inside tank			Stainless steel	Stainless steel	Stainless steel
Tapping profile according EN16147			L	L	L
DHW tank ERP efficiency average / warm / cold <sup>2)</sup>		A+ to F	A/A+/A	A/A+/A	A/A+/A
DHW tank ERP average climate η / COPdHWH		η <sub>wh</sub> % / COPdHWH	112/2,80	112/2,80	107/2,68
DHW tank ERP warm climate η / COPdHWH		η <sub>wh</sub> % / COPdHWH	132/3,30	132/3,30	128/3,20
DHW tank ERP cold climate η / COPdHWH		η <sub>wh</sub> % / COPdHWH	88/2,20	88/2,20	84/2,10
<b>Outdoor unit</b>			<b>WH-UQZ09KE8</b>	<b>WH-UQZ12KE8</b>	<b>WH-UQZ16KE8</b>
Sound power <sup>3)</sup>	Heat	dB(A)	58	58	62
Dimension / Net weight	H x W x D	mm / kg	1410 x 1284 x 322 / 131	1410 x 1284 x 322 / 131	1410 x 1284 x 322 / 145
Refrigerant (R32) / CO <sub>2</sub> Eq.		kg / T	1,60 / 1,080	1,60 / 1,080	1,83 / 1,235
Piping diameter	Liquid / Gas	Inch (mm)	1/4 (6,35) / 1/2 (12,70)	1/4 (6,35) / 1/2 (12,70)	1/4 (6,35) / 1/2 (12,70)
Pipe length range / Elevation difference (in / out)		m / m	3 - 30 / 20	3 - 30 / 20	3 - 30 / 20
Pre-charged pipe length / Additional gas amount		m / g/m	10 / 30	10 / 30	10 / 30
Operating range - outdoor ambient	Heat	°C	-28 ~ +35	-28 ~ +35	-28 ~ +35
	Cool	°C	+10 ~ +43	+10 ~ +43	+10 ~ +43
Water outlet <sup>4)</sup>	Heat / Cool	°C	20 ~ 60 / 5 ~ 20	20 ~ 60 / 5 ~ 20	20 ~ 60 / 5 ~ 20
<b>Electrical information</b>			<b>WH-ADC0912K9E8</b>	<b>WH-ADC0912K9E8</b>	<b>WH-ADC16K9E8</b>
Electric backup heater		kW	9,00	9,00	9,00
Recommended fuse <sup>5)</sup>		A	20/20	20/20	20/20
Recommended minimum cable size, supply 1 / 2 <sup>5)</sup>		mm <sup>2</sup>	5x1,5/5x1,5	5x1,5/5x1,5	5x2,5/5x1,5

1) Scale from A+++ to D. 2) Scale from A+ to F. 3) Sound power level in accordance to EN 12102 under conditions of the EN14825. 4) Between outdoor ambient -10 °C and -15 °C, the water outlet temperature gradually decreases from 60 °C to 55 °C. 5) Check local regulations. \*EER and COP calculation is based in accordance to EN 14511. \*\*This product is designed to comply with the European drinking water standard (EU) 2020/2184. The lifespan of the product is not guaranteed in the case of the use of groundwater, such as spring water or well water, the use of tap water when salt or other impurities are contained, nor in areas of acidic water quality. Maintenance and warranty costs related to these cases are the customer's responsibility.

### Accessories

**CZ-RTW1** Optional remote controller for 2 zone control. K and L Series

**CZ-TAW1B** Optional Wi-Fi or WLAN adapter for smart control via Comfort Cloud App and/or remote maintenance via Aquarea Service Cloud

### Accessories

**CZ-TAW1-CBL** 10 m extension cable for CZ-TAW1B

**CZ-NS5P** PCB for advanced functions

**PAW-A2W-RTWIRED** Room thermostat

**PAW-A2W-RTWIRELESS** Wireless LCD room thermostat



NEW

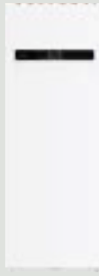

**NEW! Aquarea T-CAP All in One 185 L K Series. Three phase with Electrical Anode. Super Quiet outdoor unit - R32**

**Comfort:** Super Quiet outdoor unit (-7 dB(A)) / Constant capacity at 55 °C down to -15 °C / Operating range to -28 °C / 60 °C flow temperature at -10 °C.

**Flexibility:** Suitable for harsh-water installations / 599 x 602 footprint / Built-in magnetic water filter.

**Energy efficiency:** A+++ heating at 35 °C / A+ DHW / "A"-rated variable-speed pump / Stainless steel DHW tank with U-Vacua™ / Built-in flow meter.

**Control:** Optimised user interface and improved features (2 zone control, bivalent control).

**Connectivity:** Optional Wi-Fi and BMS integration.

Three phase (power to indoor)

Kit			KIT-AQC09K9E8AN	KIT-AQC12K9E8AN	KIT-AQC16K9E8AN
Heating capacity / COP (A +7 °C, W 35 °C)		kW / COP	9,00/5,03	12,10/4,84	16,00/4,38
Heating capacity / COP (A +7 °C, W 55 °C)		kW / COP	9,00/3,07	12,10/3,04	16,00/2,72
Heating capacity / COP (A +2 °C, W 35 °C)		kW / COP	9,00/3,69	12,00/3,44	16,00/3,10
Heating capacity / COP (A +2 °C, W 55 °C)		kW / COP	9,00/2,31	12,00/2,29	16,00/2,07
Heating capacity / COP (A -7 °C, W 35 °C)		kW / COP	9,00/3,00	12,00/2,72	16,00/2,39
Heating capacity / COP (A -7 °C, W 55 °C)		kW / COP	9,00/2,10	12,00/2,20	16,00/1,71
Cooling capacity / EER (A 35 °C, W 7 °C)		kW / EER	8,80/3,11	10,70/2,68	13,40/2,64
Cooling capacity / EER (A 35 °C, W 18 °C)		kW / EER	8,80/4,63	10,70/3,92	15,50/3,60
Heating average climate (W 35 °C / W 55 °C)	Seasonal energy efficiency	SCOP (η <sub>s</sub> %)	4,44 / 3,20 (175 / 125)	4,44 / 3,34 (175 / 131)	4,46 / 3,31 (176 / 129)
	Energy class <sup>1)</sup>		A+++ to D	A+++ / A++	A+++ / A++
Heating warm climate (W 35 °C / W 55 °C)	Seasonal energy efficiency	SCOP (η <sub>s</sub> %)	6,47 / 4,34 (256 / 171)	6,47 / 4,34 (256 / 171)	5,88 / 4,09 (232 / 160)
	Energy class <sup>1)</sup>		A+++ to D	A+++ / A+++	A+++ / A+++
Heating cold climate (W 35 °C / W 55 °C)	Seasonal energy efficiency	SCOP (η <sub>s</sub> %)	4,31 / 3,26 (169 / 127)	4,31 / 3,26 (169 / 127)	3,83 / 3,20 (150 / 125)
	Energy class <sup>1)</sup>		A+++ to D	A++ / A++	A++ / A++
<b>Indoor unit</b>			<b>WH-ADC0912K9E8AN</b>	<b>WH-ADC0912K9E8AN</b>	<b>WH-ADC16K9E8AN</b>
Sound pressure	Heat / Cool	dB(A)	33/33	33/33	33/33
Dimension	H x W x D	mm	1642 x 599 x 602	1642 x 599 x 602	1642 x 599 x 602
Net weight		kg	102	102	103
Water pipe connector		Inch	R 1½	R 1½	R 1½
A class pump	Number of speeds		Variable speed	Variable speed	Variable speed
	Input power	W	145	145	173
Heating water flow (ΔT=5 K, 35 °C)		L/min	25,8	34,4	45,9
Water volume		L	185	185	185
Maximum DHW temperature		°C	65	65	65
Material inside tank			Stainless steel	Stainless steel	Stainless steel
Tapping profile according EN16147			L	L	L
DHW tank ERP efficiency average / warm / cold <sup>2)</sup>		A+ to F	A/A+/A	A/A+/A	A/A+/A
DHW tank ERP average climate η / COP <sub>DHW</sub>		η <sub>wh</sub> % / COP <sub>DHW</sub>	112/2,80	112/2,80	107/2,68
DHW tank ERP warm climate η / COP <sub>DHW</sub>		η <sub>wh</sub> % / COP <sub>DHW</sub>	132/3,30	132/3,30	128/3,20
DHW tank ERP cold climate η / COP <sub>DHW</sub>		η <sub>wh</sub> % / COP <sub>DHW</sub>	88/2,20	88/2,20	84/2,10
<b>Outdoor unit</b>			<b>WH-UQZ09KE8</b>	<b>WH-UQZ12KE8</b>	<b>WH-UQZ16KE8</b>
Sound power <sup>3)</sup>	Heat	dB(A)	58	58	62
Dimension / Net weight	H x W x D	mm / kg	1410 x 1284 x 322 / 131	1410 x 1284 x 322 / 131	1410 x 1284 x 322 / 145
Refrigerant (R32) / CO <sub>2</sub> Eq.		kg / T	1,60 / 1,080	1,60 / 1,080	1,83 / 1,235
Piping diameter	Liquid / Gas	Inch (mm)	1/4 (6,35) / 1/2 (12,70)	1/4 (6,35) / 1/2 (12,70)	1/4 (6,35) / 1/2 (12,70)
Pipe length range / Elevation difference (in / out)		m / m	3 ~ 30 / 20	3 ~ 30 / 20	3 ~ 30 / 20
Pre-charged pipe length / Additional gas amount		m / g/m	10 / 30	10 / 30	10 / 30
Operating range - outdoor ambient	Heat	°C	-28 ~ +35	-28 ~ +35	-28 ~ +35
	Cool	°C	+10 ~ +43	+10 ~ +43	+10 ~ +43
Water outlet <sup>4)</sup>	Heat / Cool	°C	20 ~ 60 / 5 ~ 20	20 ~ 60 / 5 ~ 20	20 ~ 60 / 5 ~ 20
<b>Electrical information</b>			<b>WH-ADC0912K9E8AN</b>	<b>WH-ADC0912K9E8AN</b>	<b>WH-ADC16K9E8AN</b>
Electric backup heater		kW	9,00	9,00	9,00
Recommended fuse <sup>5)</sup>		A	20 / 20	20 / 20	20 / 20
Recommended minimum cable size, supply 1 / 2 <sup>5)</sup>		mm <sup>2</sup>	5x1,5 / 5x1,5	5x1,5 / 5x1,5	5x2,5 / 5x1,5

1) Scale from A+++ to D. 2) Scale from A+ to F. 3) Sound power level in accordance to EN 12102 under conditions of the EN14825. 4) Between outdoor ambient -10 °C and -15 °C, the water outlet temperature gradually decreases from 60 °C to 55 °C. 5) Check local regulations. \*\*EER and COP calculation is based in accordance to EN 14511. \*\*This product is designed to comply with the European drinking water standard (EU) 2020/2184. The lifespan of the product is not guaranteed in the case of the use of groundwater, such as spring water or well water, the use of tap water when salt or other impurities are contained, nor in areas of acidic water quality. Maintenance and warranty costs related to these cases are the customer's responsibility.

Accessories	
<b>CZ-RTW1</b>	Optional remote controller for 2 zone control. K and L Series
<b>CZ-TAW1B</b>	Optional Wi-Fi or WLAN adapter for smart control via Comfort Cloud App and/or remote maintenance via Aquarea Service Cloud

Accessories	
<b>CZ-TAW1-CBL</b>	10 m extension cable for CZ-TAW1B
<b>CZ-NS5P</b>	PCB for advanced functions
<b>PAW-A2W-RTWIRED</b>	Room thermostat
<b>PAW-A2W-RTWIRELESS</b>	Wireless LCD room thermostat



## NEW! Aquarea T-CAP All in One 260 L K Series. Three phase. Super Quiet outdoor unit - R32

**Comfort:** Super Quiet outdoor unit (-7 dB(A)) / Constant capacity at 55 °C down to -15 °C / Operating range to -28 °C / 60 °C flow temperature at -10 °C.

**Flexibility:** 599 x 602 footprint / Built-in magnetic water filter.

**Energy efficiency:** A+++ heating at 35 °C / A+ DHW / "A"-rated variable-speed pump / Stainless steel DHW tank with U-Vacua™ / Built-in flow meter.

**Control:** Optimised user interface and improved features (2 zone control, bivalent control).

**Connectivity:** Optional Wi-Fi and BMS integration.

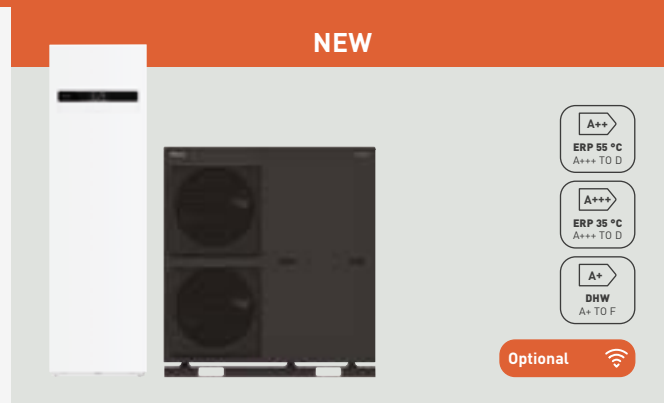

Three phase (power to indoor)

Kit			KIT-AQC09K9E83	KIT-AQC12K9E83	KIT-AQC16K9E83
Heating capacity / COP (A +7 °C, W 35 °C)	kW / COP		9,00/5,03	12,10/4,84	16,00/4,38
Heating capacity / COP (A +7 °C, W 55 °C)	kW / COP		9,00/3,07	12,10/3,04	16,00/2,72
Heating capacity / COP (A +2 °C, W 35 °C)	kW / COP		9,00/3,69	12,00/3,44	16,00/3,10
Heating capacity / COP (A +2 °C, W 55 °C)	kW / COP		9,00/2,31	12,00/2,29	16,00/2,07
Heating capacity / COP (A -7 °C, W 35 °C)	kW / COP		9,00/3,00	12,00/2,72	16,00/2,39
Heating capacity / COP (A -7 °C, W 55 °C)	kW / COP		9,00/2,10	12,00/2,29	16,00/1,71
Cooling capacity / EER (A 35 °C, W 7 °C)	kW / EER		8,80/3,11	10,70/2,68	13,40/2,64
Cooling capacity / EER (A 35 °C, W 18 °C)	kW / EER		8,80/4,63	10,70/3,92	15,50/3,60
Heating average climate (W 35 °C / W 55 °C)	Seasonal energy efficiency	SCOP (η <sub>s</sub> %)	4,44 / 3,20 (175 / 125)	4,44 / 3,34 (175 / 131)	4,46 / 3,31 (176 / 129)
	Energy class <sup>1)</sup>		A+++ / A++	A+++ / A++	A+++ / A++
Heating warm climate (W 35 °C / W 55 °C)	Seasonal energy efficiency	SCOP (η <sub>s</sub> %)	6,47 / 4,34 (256 / 171)	6,47 / 4,34 (256 / 171)	5,88 / 4,09 (232 / 160)
	Energy class <sup>1)</sup>		A+++ / A+++	A+++ / A+++	A+++ / A+++
Heating cold climate (W 35 °C / W 55 °C)	Seasonal energy efficiency	SCOP (η <sub>s</sub> %)	4,31 / 3,26 (169 / 127)	4,31 / 3,26 (169 / 127)	3,83 / 3,20 (150 / 125)
	Energy class <sup>1)</sup>		A++ / A++	A++ / A++	A++ / A++
<b>Indoor unit</b>			<b>WH-ADC0912K9E83</b>	<b>WH-ADC0912K9E83</b>	<b>WH-ADC16K9E83</b>
Sound pressure	Heat / Cool	dB(A)	33/33	33/33	33/33
Dimension	H x W x D	mm	2036 x 599 x 602	2036 x 599 x 602	2036 x 599 x 602
Net weight		kg	119	119	120
Water pipe connector		Inch	R 1¼	R 1¼	R 1¼
A class pump	Number of speeds		Variable speed	Variable speed	Variable speed
	Input power	W	145	145	145
Heating water flow (ΔT=5 K, 35 °C)		L/min	25,8	34,4	45,9
Water volume		L	260	260	260
Maximum DHW temperature		°C	65	65	65
Material inside tank			Stainless steel	Stainless steel	Stainless steel
Tapping profile according EN16147			XL	XL	XL
DHW tank ERP efficiency average / warm / cold <sup>2)</sup>	A+ to F		A+ / A+ / A	A+ / A+ / A	A+ / A+ / A
DHW tank ERP average climate η / COPdHW	η <sub>wh</sub> % / COPdHW		123/3,08	123/3,08	98/2,45
DHW tank ERP warm climate η / COPdHW	η <sub>wh</sub> % / COPdHW		134/3,35	134/3,35	123/3,08
DHW tank ERP cold climate η / COPdHW	η <sub>wh</sub> % / COPdHW		94/2,35	94/2,35	80/2,00
<b>Outdoor unit</b>			<b>WH-UQZ09KE8</b>	<b>WH-UQZ12KE8</b>	<b>WH-UQZ16KE8</b>
Sound power <sup>3)</sup>	Heat	dB(A)	58	58	62
Dimension / Net weight	H x W x D	mm / kg	1410 x 1284 x 322 / 131	1410 x 1284 x 322 / 131	1410 x 1284 x 322 / 145
Refrigerant (R32) / CO <sub>2</sub> Eq.		kg / T	1,60 / 1,080	1,60 / 1,080	1,83 / 1,235
Piping diameter	Liquid / Gas	Inch (mm)	1/4 (6,35) / 1/2 (12,70)	1/4 (6,35) / 1/2 (12,70)	1/4 (6,35) / 1/2 (12,70)
Pipe length range / Elevation difference (in / out)		m / m	3 - 30 / 20	3 - 30 / 20	3 - 30 / 20
Pre-charged pipe length / Additional gas amount		m / g/m	10 / 30	10 / 30	10 / 30
Operating range - outdoor ambient	Heat	°C	-28 ~ +35	-28 ~ +35	-28 ~ +35
	Cool	°C	+10 ~ +43	+10 ~ +43	+10 ~ +43
Water outlet <sup>4)</sup>	Heat / Cool	°C	20 ~ 60 / 5 ~ 20	20 ~ 60 / 5 ~ 20	20 ~ 60 / 5 ~ 20
<b>Electrical information</b>			<b>WH-ADC0912K9E83</b>	<b>WH-ADC0912K9E83</b>	<b>WH-ADC16K9E83</b>
Electric backup heater		kW	9,00	9,00	9,00
Recommended fuse <sup>5)</sup>		A	20/20	20/20	20/20
Recommended minimum cable size, supply 1 / 2 <sup>5)</sup>		mm <sup>2</sup>	5x1,5/5x1,5	5x1,5/5x1,5	5x2,5/5x1,5

1) Scale from A+++ to D. 2) Scale from A+ to F. 3) Sound power level in accordance to EN 12102 under conditions of the EN14825. 4) Between outdoor ambient -10 °C and -15 °C, the water outlet temperature gradually decreases from 60 °C to 55 °C. 5) Check local regulations. \*EER and COP calculation is based in accordance to EN 14511. \*\*This product is designed to comply with the European drinking water standard (EU) 2020/2184. The lifespan of the product is not guaranteed in the case of the use of groundwater, such as spring water or well water, the use of tap water when salt or other impurities are contained, nor in areas of acidic water quality. Maintenance and warranty costs related to these cases are the customer's responsibility.

### Accessories

<b>CZ-RTW1</b>	Optional remote controller for 2 zone control. K and L Series
<b>CZ-TAW1B</b>	Optional Wi-Fi or WLAN adapter for smart control via Comfort Cloud App and/or remote maintenance via Aquarea Service Cloud

### Accessories

<b>CZ-TAW1-CBL</b>	10 m extension cable for CZ-TAW1B
<b>CZ-NS5P</b>	PCB for advanced functions
<b>PAW-A2W-RTWIRED</b>	Room thermostat
<b>PAW-A2W-RTWIREDLESS</b>	Wireless LCD room thermostat



NEW

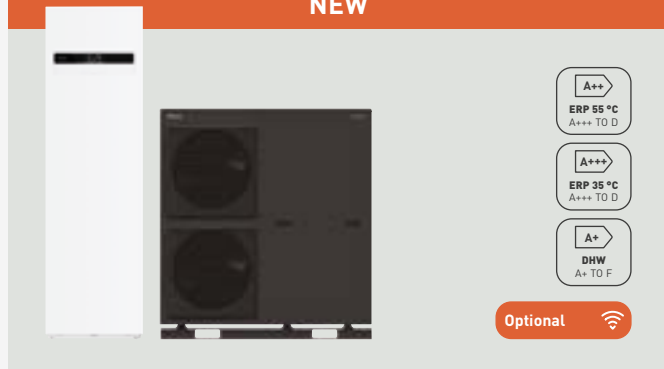

**NEW! Aquarea T-CAP All in One 260 L K Series. Three phase with Electrical Anode. Super Quiet outdoor unit - R32**

**Comfort:** Super Quiet outdoor unit (-7 dB(A)) / Constant capacity at 55 °C down to -15 °C / Operating range to -28 °C / 60 °C flow temperature at -10 °C.

**Flexibility:** Suitable for harsh-water installations / 599 x 602 footprint / Built-in magnetic water filter.

**Energy efficiency:** A+++ heating at 35 °C / A+ DHW / "A"-rated variable-speed pump / Stainless steel DHW tank with U-Vacua™ / Built-in flow meter.

**Control:** Optimised user interface and improved features (2 zone control, bivalent control).

**Connectivity:** Optional Wi-Fi and BMS integration.

Three phase (power to indoor)

Kit		KIT-AQC09K9E8AN3		KIT-AQC12K9E8AN3		KIT-AQC16K9E8AN3	
Heating capacity / COP (A +7 °C, W 35 °C)		kW / COP		12,10/4,84		16,00/4,38	
Heating capacity / COP (A +7 °C, W 55 °C)		kW / COP		12,10/3,04		16,00/2,72	
Heating capacity / COP (A +2 °C, W 35 °C)		kW / COP		12,00/3,44		16,00/3,10	
Heating capacity / COP (A +2 °C, W 55 °C)		kW / COP		12,00/2,29		16,00/2,07	
Heating capacity / COP (A -7 °C, W 35 °C)		kW / COP		12,00/2,72		16,00/2,39	
Heating capacity / COP (A -7 °C, W 55 °C)		kW / COP		12,00/2,29		16,00/1,71	
Cooling capacity / EER (A 35 °C, W 7 °C)		kW / EER		10,70/2,68		13,40/2,64	
Cooling capacity / EER (A 35 °C, W 18 °C)		kW / EER		10,70/3,92		15,50/3,60	
Heating average climate (W 35 °C / W 55 °C)		Seasonal energy efficiency	SCOP (η <sub>s</sub> %)	4,44 / 3,20 (175 / 125)	4,44 / 3,34 (175 / 131)	4,46 / 3,31 (176 / 129)	
		Energy class <sup>1)</sup>		A+++ to D	A+++ / A++	A+++ / A++	
Heating warm climate (W 35 °C / W 55 °C)		Seasonal energy efficiency	SCOP (η <sub>s</sub> %)	6,47 / 4,34 (256 / 171)	6,47 / 4,34 (256 / 171)	5,88 / 4,09 (232 / 160)	
		Energy class <sup>1)</sup>		A+++ to D	A+++ / A+++	A+++ / A+++	
Heating cold climate (W 35 °C / W 55 °C)		Seasonal energy efficiency	SCOP (η <sub>s</sub> %)	4,31 / 3,26 (169 / 127)	4,31 / 3,26 (169 / 127)	3,83 / 3,20 (150 / 125)	
		Energy class <sup>1)</sup>		A+++ to D	A++ / A++	A++ / A++	
<b>Indoor unit</b>		<b>WH-ADC0912K9E8AN3</b>		<b>WH-ADC0912K9E8AN3</b>		<b>WH-ADC16K9E8AN3</b>	
Sound pressure	Heat / Cool	dB(A)		33/33		33/33	
Dimension	H x W x D	mm		2036 x 599 x 602		2036 x 599 x 602	
Net weight		kg		119		120	
Water pipe connector		Inch		R 1½		R 1½	
A class pump	Number of speeds	Variable speed		Variable speed		Variable speed	
	Input power	W		145		145	
Heating water flow (ΔT=5 K, 35 °C)		L/min		25,8		34,4	
Water volume		L		260		260	
Maximum DHW temperature		°C		65		65	
Material inside tank		Stainless steel		Stainless steel		Stainless steel	
Tapping profile according EN16147		XL		XL		XL	
DHW tank ERP efficiency average / warm / cold <sup>2)</sup>		A+ to F		A+ / A+ / A		A+ / A+ / A	
DHW tank ERP average climate η / COP <sub>DHW</sub>		η <sub>wh</sub> % / COP <sub>DHW</sub>		123 / 3,08		98 / 2,45	
DHW tank ERP warm climate η / COP <sub>DHW</sub>		η <sub>wh</sub> % / COP <sub>DHW</sub>		134 / 3,35		123 / 3,08	
DHW tank ERP cold climate η / COP <sub>DHW</sub>		η <sub>wh</sub> % / COP <sub>DHW</sub>		94 / 2,35		80 / 2,00	
<b>Outdoor unit</b>		<b>WH-UQZ09KE8</b>		<b>WH-UQZ12KE8</b>		<b>WH-UQZ16KE8</b>	
Sound power <sup>3)</sup>	Heat	dB(A)		58		62	
Dimension / Net weight	H x W x D	mm / kg		1410 x 1284 x 322 / 131		1410 x 1284 x 322 / 131	
Refrigerant (R32) / CO <sub>2</sub> Eq.		kg / T		1,60 / 1,080		1,83 / 1,235	
Piping diameter	Liquid / Gas	Inch (mm)		1/4 (6,35) / 1/2 (12,70)		1/4 (6,35) / 1/2 (12,70)	
Pipe length range / Elevation difference (in / out)		m / m		3 ~ 30 / 20		3 ~ 30 / 20	
Pre-charged pipe length / Additional gas amount		m / g/m		10 / 30		10 / 30	
Operating range - outdoor ambient	Heat	°C		-28 ~ +35		-28 ~ +35	
	Cool	°C		+10 ~ +43		+10 ~ +43	
Water outlet <sup>4)</sup>	Heat / Cool	°C		20 ~ 60 / 5 ~ 20		20 ~ 60 / 5 ~ 20	

Electrical information		WH-ADC0912K9E8AN3		WH-ADC0912K9E8AN3		WH-ADC16K9E8AN3	
Electric backup heater		kW		9,00		9,00	
Recommended fuse <sup>5)</sup>		A		20 / 20		20 / 20	
Recommended minimum cable size, supply 1 / 2 <sup>5)</sup>		mm <sup>2</sup>		5x1,5 / 5x1,5		5x2,5 / 5x1,5	

1) Scale from A+++ to D. 2) Scale from A+ to F. 3) Sound power level in accordance to EN 12102 under conditions of the EN14825. 4) Between outdoor ambient -10 °C and -15 °C, the water outlet temperature gradually decreases from 60 °C to 55 °C. 5) Check local regulations. \*EER and COP calculation is based in accordance to EN 14511. \*\*This product is designed to comply with the European drinking water standard (EU) 2020/2184. The lifespan of the product is not guaranteed in the case of the use of groundwater, such as spring water or well water, the use of tap water when salt or other impurities are contained, nor in areas of acidic water quality. Maintenance and warranty costs related to these cases are the customer's responsibility.

Accessories	
<b>CZ-RTW1</b>	Optional remote controller for 2 zone control. K and L Series
<b>CZ-TAW1B</b>	Optional Wi-Fi or WLAN adapter for smart control via Comfort Cloud App and/or remote maintenance via Aquarea Service Cloud

Accessories	
<b>CZ-TAW1-CBL</b>	10 m extension cable for CZ-TAW1B
<b>CZ-NS5P</b>	PCB for advanced functions
<b>PAW-A2W-RTWIRED</b>	Room thermostat
<b>PAW-A2W-RTWIRELESS</b>	Wireless LCD room thermostat



## Aquarea T-CAP Bi-bloc K Series. Single phase / Three phase - R32

**Comfort:** Constant capacity at 55 °C down to -15 °C / Operating range to -28 °C / 60 °C flow temperature at -10 °C.

**Flexibility:** Built-in magnetic water filter.

**Energy efficiency:** A+++ heating at 35 °C / "A"-rated variable-speed pump / Built-in flow meter.

**Control:** Optimised user interface and improved features (2 zone control, bivalent control).

**Connectivity:** Optional Wi-Fi and BMS integration.

Check all our certified heat pumps on:  
[www.heatpumpkeymark.com](http://www.heatpumpkeymark.com)



Optional

		Single phase (power to indoor)			Three phase (power to indoor)		
Kit 3 kW electric heater		KIT-WXC09K3E5		KIT-WXC09K3E8		—	
Kit 6 kW electric heater		KIT-WXC09K6E5		KIT-WXC12K6E5		—	
Kit 9 kW electric heater		—		KIT-WXC09K9E8		KIT-WXC12K9E8 KIT-WXC16K9E8	
Heating capacity / COP (A +7 °C, W 35 °C)	kW / COP	9,00/5,03	12,10/4,84	9,00/5,03	12,10/4,84	16,00/4,38	
Heating capacity / COP (A +7 °C, W 55 °C)	kW / COP	9,00/3,07	12,10/3,04	9,00/3,07	12,10/3,04	16,00/2,72	
Heating capacity / COP (A +2 °C, W 35 °C)	kW / COP	9,00/3,69	12,00/3,44	9,00/3,69	12,00/3,44	16,00/3,10	
Heating capacity / COP (A +2 °C, W 55 °C)	kW / COP	9,00/2,31	12,00/2,29	9,00/2,31	12,00/2,29	16,00/2,07	
Heating capacity / COP (A -7 °C, W 35 °C)	kW / COP	9,00/3,00	12,00/2,72	9,00/3,00	12,00/2,72	16,00/2,39	
Heating capacity / COP (A -7 °C, W 55 °C)	kW / COP	9,00/2,10	12,00/2,29	9,00/2,10	12,00/2,29	16,00/1,71	
Cooling capacity / EER (A 35 °C, W 7 °C)	kW / EER	8,80/3,11	10,70/2,68	8,80/3,11	10,70/2,68	13,40/2,64	
Cooling capacity / EER (A 35 °C, W 18 °C)	kW / EER	8,80/4,63	10,70/3,92	8,80/4,63	10,70/3,92	15,50/3,60	
Heating average climate (W 35 °C / W 55 °C)	Seasonal energy efficiency	SCOP (η <sub>s</sub> %)		4,96/3,57(195/140)		4,96/3,57(195/140)	
	Energy class <sup>1)</sup>	A+++ to D		A+++ / A+++		A+++ / A+++	
Heating warm climate (W 35 °C / W 55 °C)	Seasonal energy efficiency	SCOP (η <sub>s</sub> %)		6,47/4,34(256/171)		6,47/4,34(256/171)	
	Energy class <sup>1)</sup>	A+++ to D		A+++ / A+++		A+++ / A+++	
Heating cold climate (W 35 °C / W 55 °C)	Seasonal energy efficiency	SCOP (η <sub>s</sub> %)		4,31/3,26(169/127)		4,31/3,26(169/127)	
	Energy class <sup>1)</sup>	A+++ to D		A++ / A++		A++ / A++	
<b>Indoor unit 3 kW electric heater</b>		<b>WH-SXC09K3E5</b>		<b>WH-SXC09K3E8</b>		—	
<b>Indoor unit 6 kW electric heater</b>		<b>WH-SXC09K6E5</b>		<b>WH-SXC12K6E5</b>		—	
<b>Indoor unit 9 kW electric heater</b>		—		<b>WH-SXC09K9E8</b>		<b>WH-SXC12K9E8 WH-SXC16K9E8</b>	
Sound pressure	Heat / Cool	dB(A)		33/33		33/33	
Dimension	H x W x D	mm		892 x 500 x 348		892 x 500 x 348	
Net weight 3 kW / 6 kW / 9 kW		kg		40/41 / —		— / — / 41	
Water pipe connector		Inch		R 1 1/4		R 1 1/4	
A class pump	Number of speeds	Variable speed		Variable speed		Variable speed	
	Input power	W		145		145	
Heating water flow (ΔT=5 K, 35 °C)		L/min		25,8		34,4	
<b>Outdoor unit</b>		<b>WH-UXZ09K5</b>		<b>WH-UXZ12K5</b>		<b>WH-UXZ09K8 WH-UXZ12K8 WH-UXZ16K8</b>	
Sound power <sup>2)</sup>	Heat	dB(A)		65		65	
Dimension	H x W x D	mm		1340 x 900 x 320		1340 x 900 x 320	
Net weight		kg		88		90	
Refrigerant (R32) / CO <sub>2</sub> Eq.		kg / T		1,60/1,080		1,60/1,080	
Piping diameter	Liquid / Gas	Inch (mm)		1/4(6,35)/1/2(12,70)		1/4(6,35)/1/2(12,70)	
Pipe length range / Elevation difference (in / out)		m		3-30/20		3-30/20	
Pre-charged pipe length / Additional gas amount		m / g/m		10/30		10/30	
Operating range - outdoor ambient	Heat	°C		-28 ~ +35		-28 ~ +35	
	Cool	°C		+10 ~ +43		+10 ~ +43	
Water outlet <sup>3)</sup>	Heat / Cool	°C		20 ~ 60/5 ~ 20		20 ~ 60/5 ~ 20	
<b>Electrical information</b>		<b>Heater</b>		<b>3 kW</b>		<b>6 kW</b>	
Electric backup heater		kW		3,00		6,00	
Recommended fuse <sup>4)</sup>		A		30/15 or 16		30/30	
Recommended minimum cable size, supply 1 / 2 <sup>4)</sup>		mm <sup>2</sup>		3x4,0/3x1,5		3x4,0/3x4,0	

1) Scale from A+++ to D. 2) Sound power level in accordance to EN 12102 under conditions of the EN14825. 3) Between outdoor ambient -10 °C and -15 °C, the water outlet temperature gradually decreases from 60 °C to 55 °C. 4) Check local regulations. \*EER and COP calculation is based in accordance to EN 14511. \*\*This product is designed to comply with the European drinking water standard (EU) 2020/2184. The lifespan of the product is not guaranteed in the case of the use of groundwater, such as spring water or well water, the use of tap water when salt or other impurities are contained, nor in areas of acidic water quality. Maintenance and warranty costs related to these cases are the customer's responsibility.

Accessories	
<b>CZ-RTW1</b>	Optional remote controller for 2 zone control. K and L Series
<b>PAW-TD20C1E5-1</b>	Tank 200 L - Stainless steel
<b>PAW-TD30C1E5-1</b>	Tank 300 L - Stainless steel
<b>PAW-TA20C1E5STD</b>	Tank 200 L - Enamelled
<b>PAW-TA30C1E5STD</b>	Tank 300 L - Enamelled
<b>PAW-3WYVLV-HW</b>	3 way valve for DHW tanks
<b>CZ-NV2</b>	3 way valve kit to fit inside the hydrokit. K and L Series

Accessories	
<b>PAW-BTANK50L-2</b>	Buffer tank 50 L
<b>CZ-TAW1B</b>	Optional Wi-Fi or WLAN adapter for smart control via Comfort Cloud App and/or remote maintenance via Aquarea Service Cloud
<b>CZ-TAW1-CBL</b>	10 m extension cable for CZ-TAW1B
<b>CZ-N55P</b>	PCB for advanced functions
<b>PAW-A2W-RTWIRED</b>	Room thermostat
<b>PAW-A2W-RTWIREDLESS</b>	Wireless LCD room thermostat



NEW



**NEW! Aquarea T-CAP Bi-bloc K Series. Three phase. Super Quiet outdoor unit - R32**

**Comfort:** Super Quiet outdoor unit (-7 dB(A)) / Constant capacity at 55 °C down to -15 °C / Operating range to -28 °C / 60 °C flow temperature at -10 °C.

**Flexibility:** Built-in magnetic water filter.

**Energy efficiency:** A+++ heating at 35 °C / "A"-rated variable-speed pump / Built-in flow meter.

**Control:** Optimised user interface and improved features (2 zone control, bivalent control).

**Connectivity:** Optional Wi-Fi and BMS integration.

Three phase (power to indoor)

Kit 3 kW electric heater			KIT-WQC09K3E8		—		—	
Kit 9 kW electric heater			KIT-WQC09K9E8		KIT-WQC12K9E8		KIT-WQC16K9E8	
Heating capacity / COP (A +7 °C, W 35 °C)	kW / COP		9,00/5,03		12,10/4,84		16,00/4,38	
Heating capacity / COP (A +7 °C, W 55 °C)	kW / COP		9,00/3,07		12,10/3,04		16,00/2,72	
Heating capacity / COP (A +2 °C, W 35 °C)	kW / COP		9,00/3,69		12,00/3,44		16,00/3,10	
Heating capacity / COP (A +2 °C, W 55 °C)	kW / COP		9,00/2,31		12,00/2,29		16,00/2,07	
Heating capacity / COP (A -7 °C, W 35 °C)	kW / COP		9,00/3,00		12,00/2,72		16,00/2,39	
Heating capacity / COP (A -7 °C, W 55 °C)	kW / COP		9,00/2,10		12,00/2,29		16,00/1,71	
Cooling capacity / EER (A 35 °C, W 7 °C)	kW / EER		8,80/3,11		10,70/2,68		13,40/2,64	
Cooling capacity / EER (A 35 °C, W 18 °C)	kW / EER		8,80/4,63		10,70/3,92		15,50/3,60	
Heating average climate (W 35 °C / W 55 °C)	Seasonal energy efficiency	SCOP (η <sub>s</sub> %)	4,44 / 3,20 (175 / 125)		4,44 / 3,34 (175 / 131)		4,46 / 3,31 (176 / 129)	
	Energy class <sup>1)</sup>		A+++ to D		A+++ / A++		A+++ / A++	
Heating warm climate (W 35 °C / W 55 °C)	Seasonal energy efficiency	SCOP (η <sub>s</sub> %)	6,47 / 4,34 (256 / 171)		6,47 / 4,34 (256 / 171)		5,88 / 4,09 (232 / 160)	
	Energy class <sup>1)</sup>		A+++ to D		A+++ / A+++		A+++ / A+++	
Heating cold climate (W 35 °C / W 55 °C)	Seasonal energy efficiency	SCOP (η <sub>s</sub> %)	4,31 / 3,26 (169 / 127)		4,31 / 3,26 (169 / 127)		3,83 / 3,20 (150 / 125)	
	Energy class <sup>1)</sup>		A+++ to D		A++ / A++		A++ / A++	
<b>Indoor unit 3 kW electric heater</b>			<b>WH-SXC09K3E8</b>		<b>—</b>		<b>—</b>	
<b>Indoor unit 9 kW electric heater</b>			<b>WH-SXC09K9E8</b>		<b>WH-SXC12K9E8</b>		<b>WH-SXC16K9E8</b>	
Sound pressure	Heat / Cool	dB(A)	33/33		33/33		33/33	
Dimension	H x W x D	mm	892 x 500 x 348		892 x 500 x 348		892 x 500 x 348	
Net weight 3 kW / 9 kW		kg	40/41		—/41		—/42	
Water pipe connector		Inch	R 1¼		R 1¼		R 1¼	
A class pump	Number of speeds		Variable speed		Variable speed		Variable speed	
	Input power	W	145		145		173	
Heating water flow (ΔT=5 K, 35 °C)		L/min	25,8		34,4		45,9	
<b>Outdoor unit</b>			<b>WH-UQZ09KE8</b>		<b>WH-UQZ12KE8</b>		<b>WH-UQZ16KE8</b>	
Sound power <sup>2)</sup>	Heat	dB(A)	58		58		62	
Dimension	H x W x D	mm	1410 x 1284 x 322		1410 x 1284 x 322		1410 x 1284 x 322	
Net weight		kg	131		131		145	
Refrigerant (R32) / CO <sub>2</sub> Eq.		kg / T	1,60/1,080		1,60/1,080		1,83/1,235	
Piping diameter	Liquid / Gas	Inch (mm)	1/4 (6,35)/1/2 (12,70)		1/4 (6,35)/1/2 (12,70)		1/4 (6,35)/1/2 (12,70)	
Pipe length range / Elevation difference (in / out)		m	3 ~ 30/20		3 ~ 30/20		3 ~ 30/20	
Pre-charged pipe length / Additional gas amount		m / g/m	10/30		10/30		10/30	
Operating range - outdoor ambient	Heat	°C	-28 ~ +35		-28 ~ +35		-28 ~ +35	
	Cool	°C	+10 ~ +43		+10 ~ +43		+10 ~ +43	
Water outlet <sup>3)</sup>	Heat / Cool	°C	20 ~ 60/5 ~ 20		20 ~ 60/5 ~ 20		20 ~ 60/5 ~ 20	

Electrical information	Heater	3 kW	9 kW	12 kW	16 kW
Electric backup heater	kW	3,00	9,00	9,00	9,00
Recommended fuse <sup>4)</sup>	A	20/ 15 or 16	20/20	20/20	20/20
Recommended minimum cable size, supply 1 / 2 <sup>4)</sup>	mm <sup>2</sup>	5x1,5/ 3x1,5	5x1,5/ 5x1,5	5x1,5/ 5x1,5	5x2,5/ 5x1,5

1) Scale from A+++ to D. 2) Sound power level in accordance to EN 12102 under conditions of the EN14825. 3) Between outdoor ambient -10 °C and -15 °C, the water outlet temperature gradually decreases from 60 °C to 55 °C. 4) Check local regulations. \*EER and COP calculation is based in accordance to EN 14511. \*\*This product is designed to comply with the European drinking water standard (EU) 2020/2184. The lifespan of the product is not guaranteed in the case of the use of groundwater, such as spring water or well water, the use of tap water when salt or other impurities are contained, nor in areas of acidic water quality. Maintenance and warranty costs related to these cases are the customer's responsibility.

Accessories	
<b>CZ-RTW1</b>	Optional remote controller for 2 zone control. K and L Series
<b>PAW-TD20C1E5-1</b>	Tank 200 L - Stainless steel
<b>PAW-TD30C1E5-1</b>	Tank 300 L - Stainless steel
<b>PAW-TA20C1E5STD</b>	Tank 200 L - Enamelled
<b>PAW-TA30C1E5STD</b>	Tank 300 L - Enamelled
<b>PAW-3WYVLV-HW</b>	3 way valve for DHW tanks
<b>CZ-NV2</b>	3 way valve kit to fit inside the hydrokit. K and L Series

Accessories	
<b>PAW-BTANK50L-2</b>	Buffer tank 50 L
<b>CZ-TAW1B</b>	Optional Wi-Fi or WLAN adapter for smart control via Comfort Cloud App and/or remote maintenance via Aquarea Service Cloud
<b>CZ-TAW1-CBL</b>	10 m extension cable for CZ-TAW1B
<b>CZ-NS5P</b>	PCB for advanced functions
<b>PAW-A2W-RTWIRED</b>	Room thermostat
<b>PAW-A2W-RTWIREDLESS</b>	Wireless LCD room thermostat



## Aquarea High Performance All in One 185 L K Series. Single phase - R32

**Energy efficiency:** A+++ heating at 35 °C / A+ DHW / COP up to 5,33 / DHW COP up to 3,50 / "A"-rated variable-speed pump / Stainless steel DHW tank with U-Vacua™.

**Flexibility:** 599 x 602 footprint / Built-in magnetic water filter.

**Comfort:** Operation without backup heater down to -25 °C / 60 °C flow temperature at -10 °C.

**Control:** Optimised user interface and improved features (2 zone control, bivalent control).

**Connectivity:** Optional Wi-Fi and BMS integration.

Check all our certified heat pumps on:  
[www.heatpumpkeymark.com](http://www.heatpumpkeymark.com)



		Single phase (power to indoor)									
		KIT-ADC03K3E5		KIT-ADC05K3E5		KIT-ADC07K3E5		KIT-ADC09K3E5		—	
		KIT-ADC03K6E5		KIT-ADC05K6E5		KIT-ADC07K6E5		KIT-ADC09K6E5		KIT-ADC12K6E5	
Heating capacity / COP (A +7 °C, W 35 °C)	kW / COP	3,20/5,33		5,00/5,10		7,00/4,86		9,00/4,55		12,10/4,78	
Heating capacity / COP (A +7 °C, W 55 °C)	kW / COP	3,20/2,81		5,00/3,03		7,00/2,92		8,90/2,93		12,00/2,96	
Heating capacity / COP (A +2 °C, W 35 °C)	kW / COP	3,20/3,64		5,00/3,57		6,85/3,43		7,00/3,40		11,50/3,44	
Heating capacity / COP (A +2 °C, W 55 °C)	kW / COP	3,20/2,19		5,00/2,29		6,25/2,23		6,30/2,18		9,20/2,25	
Heating capacity / COP (A -7 °C, W 35 °C)	kW / COP	3,30/2,80		5,00/2,79		5,75/2,95		6,25/2,84		10,10/2,74	
Heating capacity / COP (A -7 °C, W 55 °C)	kW / COP	3,20/1,79		5,00/1,89		5,35/1,98		5,90/1,93		8,40/1,97	
Cooling capacity / EER (A 35 °C, W 7 °C)	kW / EER	3,20/3,52		5,00/3,05		6,70/3,03		8,20/2,72		10,70/2,68	
Cooling capacity / EER (A 35 °C, W 18 °C)	kW / EER	3,20/4,71		5,00/4,90		6,70/4,72		9,00/4,18		10,70/3,92	
Heating average climate (W 35 °C / W 55 °C)	Seasonal energy efficiency	SCOP (η <sub>s</sub> %)		5,07/3,47(200/136)		5,12/3,63(202/142)		4,90/3,62(193/142)		4,44/3,41(175/133)	
	Energy class <sup>1)</sup>	A+++ to D		A+++ / A++		A+++ / A++		A+++ / A++		A+++ / A++	
Heating warm climate (W 35 °C / W 55 °C)	Seasonal energy efficiency	SCOP (η <sub>s</sub> %)		6,20/4,20(245/165)		6,00/4,20(237/165)		5,75/4,07(227/160)		6,47/4,34(256/171)	
	Energy class <sup>1)</sup>	A+++ to D		A+++ / A+++		A+++ / A+++		A+++ / A+++		A+++ / A+++	
Heating cold climate (W 35 °C / W 55 °C)	Seasonal energy efficiency	SCOP (η <sub>s</sub> %)		4,00/2,83(157/110)		4,08/2,95(160/115)		4,18/2,98(164/116)		4,31/3,26(169/127)	
	Energy class <sup>1)</sup>	A+++ to D		A++ / A+		A++ / A+		A++ / A+		A++ / A++	
<b>Indoor unit 3 kW electric heater</b>		<b>WH-ADC0309K3E5</b>		<b>WH-ADC0309K3E5</b>		<b>WH-ADC0309K3E5</b>		<b>WH-ADC0309K3E5</b>		—	
<b>Indoor unit 6 kW electric heater</b>		<b>WH-ADC0309K6E5</b>		<b>WH-ADC0309K6E5</b>		<b>WH-ADC0309K6E5</b>		<b>WH-ADC0309K6E5</b>		<b>WH-ADC0912K6E5</b>	
Sound pressure	Heat / Cool	dB(A)		28/28		28/28		28/28		33/33	
Dimension	HxWxD	mm		1642x599x602		1642x599x602		1642x599x602		1642x599x602	
Net weight 3 kW / 6 kW		kg		100/101		100/101		100/101		— / 101	
Water pipe connector		Inch		R 1¼		R 1¼		R 1¼		R 1¼	
A class pump	Number of speeds	Variable speed		Variable speed		Variable speed		Variable speed		Variable speed	
	Input power	W		145		145		145		145	
Heating water flow (ΔT=5 K, 35 °C)		L/min		9,2		14,3		20,1		25,8	
Water volume		L		185		185		185		185	
Maximum DHW temperature		°C		65		65		65		65	
Material inside tank		Stainless steel		Stainless steel		Stainless steel		Stainless steel		Stainless steel	
Tapping profile according EN16147		L		L		L		L		L	
DHW tank ERP efficiency average / warm / cold <sup>2)</sup>		A+ to F		A+ / A++ / A		A+ / A++ / A		A+ / A++ / A		A+ / A / A	
DHW tank ERP average climate η / COP <sub>DHW</sub>	η <sub>wh</sub> % / COP <sub>DHW</sub>	128/3,20		140/3,50		140/3,50		140/3,50		100/2,50	
DHW tank ERP warm climate η / COP <sub>DHW</sub>	η <sub>wh</sub> % / COP <sub>DHW</sub>	154/3,86		160/4,00		160/4,00		160/4,00		116/2,90	
DHW tank ERP cold climate η / COP <sub>DHW</sub>	η <sub>wh</sub> % / COP <sub>DHW</sub>	99/2,48		112/2,80		112/2,80		112/2,80		80/2,00	
<b>Outdoor unit</b>		<b>WH-UDZ03KE5</b>		<b>WH-UDZ05KE5</b>		<b>WH-UDZ07KE5</b>		<b>WH-UDZ09KE5</b>		<b>WH-UDZ12KE5</b>	
Sound power <sup>3)</sup>	Heat	dB(A)		55		56		56		65	
Dimension / Net weight	HxWxD	mm / kg		622x824x298/37		795x875x380/55		795x875x380/55		1340x900x320/88	
Refrigerant (R32) / CO <sub>2</sub> Eq.		kg / T		0,9/0,608		1,3/0,878		1,3/0,878		1,6/1,080	
Piping diameter	Liquid / Gas	Inch (mm)		1/4(6,35)/1/2(12,70)		1/4(6,35)/5/8(15,88)		1/4(6,35)/5/8(15,88)		1/4(6,35)/1/2(12,70)	
Pipe length range / Elevation difference (in / out)		m / m		3 - 25/20		3 - 40(3 - 50) <sup>4)</sup> / 30		3 - 40(3 - 50) <sup>4)</sup> / 30		3 - 30(3 - 50) <sup>4)</sup> / 20(30) <sup>5)</sup>	
Pre-charged pipe length / Additional gas amount		m / g/m		10/20		10/25		10/25		10/30	
Operating range - outdoor ambient	Heat	°C		-20 ~ +35		-25 ~ +35		-25 ~ +35		-25 ~ +35	
	Cool	°C		+10 ~ +43		+10 ~ +43		+10 ~ +43		+10 ~ +43	
Water outlet <sup>6)</sup>	Heat / Cool	°C		20 - 60/5 - 20		20 - 60/5 - 20		20 - 60/5 - 20		20 - 60/5 - 20	
<b>Electrical information</b>		<b>Heater</b>		<b>3 kW</b>		<b>6 kW</b>		<b>3 kW</b>		<b>6 kW</b>	
Electric backup heater		kW		3,00		6,00		3,00		6,00	
Recommended fuse <sup>7)</sup>		A		16/16		16/30		25/30		30/30	
Recommended minimum cable size, supply 1 / 2 <sup>7)</sup>		mm <sup>2</sup>		3x1,5/3x1,5		3x1,5/3x4,0		3x2,5/3x4,0		3x2,5/3x4,0	

1) Scale from A+++ to D. 2) Scale from A+ to F. 3) Sound power level in accordance to EN 12102 under conditions of the EN14825. 4) Operation range down to -25 °C in heating with 3 - 40 m pipe length range, operation range down to -15 °C in heating with 3 - 50 m pipe length range. 5) Ambient temperature down to -10 °C. Below -10 °C, permitted piping length and elevation difference is 3 - 30 m, 20 m. 6) Between outdoor ambient -10 °C and -15 °C, the water outlet temperature gradually decreases from 60 °C to 55 °C. 7) Check local regulations. \*EER and COP calculation is based in accordance to EN 14511. \*\*This product is designed to comply with the European drinking water standard [EU] 2020/2184. The lifespan of the product is not guaranteed in the case of the use of groundwater, such as spring water or well water, the use of tap water when salt or other impurities are contained, nor in areas of acidic water quality. Maintenance and warranty costs related to these cases are the customer's responsibility.

Accessories	
<b>CZ-RTW1</b>	Optional remote controller for 2 zone control. K and L Series
<b>CZ-TAW1B</b>	Optional Wi-Fi or WLAN adapter for smart control via Comfort Cloud App and/or remote maintenance via Aquarea Service Cloud

Accessories	
<b>CZ-TAW1-CBL</b>	10 m extension cable for CZ-TAW1B
<b>CZ-NS5P</b>	PCB for advanced functions
<b>PAW-A2W-RTWIRED</b>	Room thermostat
<b>PAW-A2W-RTWIREDLESS</b>	Wireless LCD room thermostat



Check all our certified heat pumps on:  
www.heatpumpkeymark.com



### Aquarea High Performance All in One 185 L K Series. Single phase with Electrical Anode - R32

**Energy efficiency:** A+++ heating at 35 °C / A+ DHW / COP up to 5,33 / DHW COP up to 3,50 / "A"-rated variable-speed pump / Stainless steel DHW tank with U-Vacua™.

**Flexibility:** Suitable for harsh-water installations / 599 x 602 footprint / Built-in magnetic water filter.

**Comfort:** Operation without backup heater down to -25 °C / 60 °C flow temperature at -10 °C.

**Control:** Optimised user interface and improved features (2 zone control, bivalent control).

**Connectivity:** Optional Wi-Fi and BMS integration.

		Single phase (power to indoor)							
Kit 3 kW electric heater		KIT-	ADC03K3E5AN	ADC05K3E5AN	ADC07K3E5AN	ADC09K3E5AN	—		
Kit 6 kW electric heater		KIT-	ADC03K6E5AN	ADC05K6E5AN	ADC07K6E5AN	ADC09K6E5AN	ADC12K6E5AN	ADC16K6E5AN	
Heating capacity / COP (A +7 °C, W 35 °C)	kW / COP		3,20/5,33	5,00/5,10	7,00/4,86	9,00/4,55	12,10/4,78	16,00/4,31	
Heating capacity / COP (A +7 °C, W 55 °C)	kW / COP		3,20/2,81	5,00/3,03	7,00/2,92	8,90/2,93	12,00/2,96	14,70/2,72	
Heating capacity / COP (A +2 °C, W 35 °C)	kW / COP		3,20/3,64	5,00/3,57	6,85/3,43	7,00/3,40	11,50/3,44	13,00/3,18	
Heating capacity / COP (A +2 °C, W 55 °C)	kW / COP		3,20/2,19	5,00/2,29	6,25/2,23	6,30/2,18	9,20/2,25	10,00/2,24	
Heating capacity / COP (A -7 °C, W 35 °C)	kW / COP		3,30/2,80	5,00/2,79	5,75/2,95	6,25/2,84	10,10/2,74	11,70/2,61	
Heating capacity / COP (A -7 °C, W 55 °C)	kW / COP		3,20/1,79	5,00/1,89	5,35/1,98	5,90/1,93	8,40/1,97	9,10/1,85	
Cooling capacity / EER (A 35 °C, W 7 °C)	kW / EER		3,20/3,52	5,00/3,05	6,70/3,03	8,20/2,72	10,70/2,68	12,20/2,68	
Cooling capacity / EER (A 35 °C, W 18 °C)	kW / EER		3,20/4,71	5,00/4,90	6,70/4,72	9,00/4,18	10,70/3,92	13,00/3,80	
Heating average climate (W 35 °C / W 55 °C)	Seasonal energy efficiency	SCOP (η <sub>s</sub> %)	5,07/3,47(200/136)	5,12/3,63(202/142)	4,90/3,62(193/142)	4,44/3,41(175/133)	4,58/3,33(180/130)	4,46/3,40(176/133)	
	Energy class <sup>1)</sup>		A+++ to D	A+++/A++	A+++/A++	A+++/A++	A+++/A++	A+++/A++	
Heating warm climate (W 35 °C / W 55 °C)	Seasonal energy efficiency	SCOP (η <sub>s</sub> %)	6,20/4,20(245/165)	6,00/4,20(237/165)	5,75/4,07(227/160)	5,75/4,07(227/160)	6,47/4,34(256/171)	6,20/4,30(245/169)	
	Energy class <sup>1)</sup>		A+++ to D	A+++/A+++	A+++/A+++	A+++/A+++	A+++/A+++	A+++/A+++	
Heating cold climate (W 35 °C / W 55 °C)	Seasonal energy efficiency	SCOP (η <sub>s</sub> %)	4,00/2,83(157/110)	4,08/2,95(160/115)	4,18/2,98(164/116)	4,18/2,98(164/116)	4,31/3,26(169/127)	4,28/3,10(168/121)	
	Energy class <sup>1)</sup>		A+++ to D	A++/A+	A++/A+	A++/A+	A++/A+	A++/A+	
<b>Indoor unit 3 kW electric heater</b>		<b>WH-</b>	<b>ADC0309K3E5AN</b>	<b>ADC0309K3E5AN</b>	<b>ADC0309K3E5AN</b>	<b>ADC0309K3E5AN</b>	—		
<b>Indoor unit 6 kW electric heater</b>		<b>WH-</b>	<b>ADC0309K6E5AN</b>	<b>ADC0309K6E5AN</b>	<b>ADC0309K6E5AN</b>	<b>ADC0309K6E5AN</b>	<b>ADC0912K6E5AN</b>	<b>ADC16K6E5AN</b>	
Sound pressure	Heat / Cool	dB(A)	28/28	28/28	28/28	28/28	33/33	33/33	
Dimension	H x W x D	mm	1642x599x602	1642x599x602	1642x599x602	1642x599x602	1642x599x602	1642x599x602	
Net weight 3 kW / 6 kW		kg	100/101	100/101	100/101	100/101	—/101	—/101	
Water pipe connector		Inch	R 1¼	R 1¼	R 1¼	R 1¼	R 1¼	R 1¼	
A class pump	Number of speeds		Variable speed	Variable speed	Variable speed	Variable speed	Variable speed	Variable speed	
	Input power	W	145	145	145	145	145	145	
Heating water flow (ΔT=5 K, 35 °C)		L/min	9,2	14,3	20,1	25,8	34,4	45,8	
Water volume		L	185	185	185	185	185	185	
Maximum DHW temperature		°C	65	65	65	65	65	65	
Material inside tank			Stainless steel	Stainless steel	Stainless steel	Stainless steel	Stainless steel	Stainless steel	
Tapping profile according EN16147			L	L	L	L	L	L	
DHW tank ERP efficiency average / warm / cold <sup>2)</sup>		A+ to F	A+/A++/A	A+/A++/A	A+/A++/A	A+/A++/A	A+/A/A	A+/A/A	
DHW tank ERP average climate η / COP <sub>DHW</sub>	η <sub>wh</sub> % / COP <sub>DHW</sub>		128/3,20	140/3,50	140/3,50	140/3,50	100/2,50	100/2,50	
DHW tank ERP warm climate η / COP <sub>DHW</sub>	η <sub>wh</sub> % / COP <sub>DHW</sub>		154/3,86	160/4,00	160/4,00	160/4,00	116/2,90	116/2,90	
DHW tank ERP cold climate η / COP <sub>DHW</sub>	η <sub>wh</sub> % / COP <sub>DHW</sub>		99/2,48	112/2,80	112/2,80	112/2,80	80/2,00	80/2,00	
<b>Outdoor unit</b>			<b>WH-UDZ03KE5</b>	<b>WH-UDZ05KE5</b>	<b>WH-UDZ07KE5</b>	<b>WH-UDZ09KE5</b>	<b>WH-UDZ12KE5</b>	<b>WH-UDZ16KE5</b>	
Sound power <sup>3)</sup>	Heat	dB(A)	55	55	56	56	65	65	
Dimension / Net weight	H x W x D	mm / kg	622x824x298/37	795x875x380/55	795x875x380/55	795x875x380/55	1340x900x320/88	1340x900x320/88	
Refrigerant (R32) / CO <sub>2</sub> Eq.		kg / T	0,9/0,608	1,3/0,878	1,3/0,878	1,3/0,878	1,6/1,080	1,6/1,080	
Piping diameter	Liquid / Gas	Inch (mm)	1/4(6,35)/1/2(12,70)	1/4(6,35)/5/8(15,88)	1/4(6,35)/5/8(15,88)	1/4(6,35)/5/8(15,88)	1/4(6,35)/1/2(12,70)	1/4(6,35)/5/8(15,88)	
Pipe length range / Elevation difference (in / out)		m / m	3-25/20	3-40(3-50) <sup>4)</sup> /30	3-40(3-50) <sup>4)</sup> /30	3-40(3-50) <sup>4)</sup> /30	3-30(3-50) <sup>4)</sup> /20(30) <sup>5)</sup>	3-30(3-50) <sup>4)</sup> /20(30) <sup>5)</sup>	
Pre-charged pipe length / Additional gas amount		m / g/m	10/20	10/25	10/25	10/25	10/30	10/30	
Operating range - outdoor ambient	Heat	°C	-20~+35	-25~+35	-25~+35	-25~+35	-25~+35	-25~+35	
	Cool	°C	+10~+43	+10~+43	+10~+43	+10~+43	+10~+43	+10~+43	
Water outlet <sup>6)</sup>	Heat / Cool	°C	20-60/5-20	20-60/5-20	20-60/5-20	20-60/5-20	20-60/5-20	20-60/5-20	
<b>Electrical information</b>		<b>Heater</b>	<b>3 kW</b>	<b>6 kW</b>	<b>3 kW</b>	<b>6 kW</b>	<b>3 kW</b>	<b>6 kW</b>	<b>6 kW</b>
Electric backup heater		kW	3,00	6,00	3,00	6,00	3,00	6,00	
Recommended fuse <sup>7)</sup>		A	16/16	16/30	16/16	16/30	25/16	25/30	
Recommended minimum cable size, supply 1 / 2 <sup>7)</sup>		mm <sup>2</sup>	3x1,5/ 3x1,5	3x1,5/ 3x4,0	3x1,5/ 3x1,5	3x1,5/ 3x4,0	3x2,5/ 3x2,5	3x2,5/ 3x4,0	3x4,0/3x4,0

1) Scale from A+++ to D. 2) Scale from A+ to F. 3) Sound power level in accordance to EN 12102 under conditions of the EN14825. 4) Operation range down to -25 °C in heating with 3-40 m pipe length range, operation range down to -10 °C in heating with 3-50 m pipe length range. 5) Ambient temperature under to -10 °C. Below -10 °C, permitted piping length and elevation difference is 3-30 m, 20 m. 6) Between outdoor ambient -10 °C and -15 °C, the water outlet temperature gradually decreases from 60 °C to 55 °C. 7) Check local regulations. \*EER and COP calculation is based in accordance to EN 14511. \*\*This product is designed to comply with the European drinking water standard (EU) 2020/2184. The lifespan of the product is not guaranteed in the case of the use of groundwater, such as spring water or well water, the use of tap water when salt or other impurities are contained, nor in areas of acidic water quality. Maintenance and warranty costs related to these cases are the customer's responsibility.

Accessories	
<b>CZ-RTW1</b>	Optional remote controller for 2 zone control. K and L Series
<b>CZ-TAW1B</b>	Optional Wi-Fi or WLAN adapter for smart control via Comfort Cloud App and/or remote maintenance via Aquarea Service Cloud

Accessories	
<b>CZ-TAW1-CBL</b>	10 m extension cable for CZ-TAW1B
<b>CZ-NS5P</b>	PCB for advanced functions
<b>PAW-A2W-RTWIRED</b>	Room thermostat
<b>PAW-A2W-RTWIREDLESS</b>	Wireless LCD room thermostat



## Aquarea High Performance All in One 260 L K Series. Single phase with Electrical Anode - R32

**Energy efficiency:** A+++ heating at 35 °C / A+ DHW / "A"-rated variable-speed pump / Stainless steel DHW tank with U-Vacua™.

**Flexibility:** Suitable for harsh-water installations (AN version) / 599 x 602 footprint / Built-in magnetic water filter.

**Comfort:** Operation without backup heater down to -25 °C / 60 °C flow temperature at -10 °C.

**Control:** Optimised user interface and improved features (2 zone control, bivalent control).

**Connectivity:** Optional Wi-Fi and BMS integration.

Check all our certified heat pumps on:  
[www.heatpumpkeymark.com](http://www.heatpumpkeymark.com)

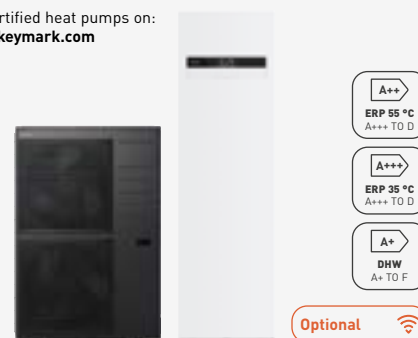

		Single phase (power to indoor)				
Kit		KIT-ADC12K6E53	KIT-ADC16K6E53	KIT-ADC12K6E5AN3	KIT-ADC16K6E5AN3	
Heating capacity / COP (A +7 °C, W 35 °C)	kW / COP	12,10/4,78	16,00/4,31	12,10/4,78	16,00/4,31	
Heating capacity / COP (A +7 °C, W 55 °C)	kW / COP	12,00/2,96	14,70/2,72	12,00/2,96	14,70/2,72	
Heating capacity / COP (A +2 °C, W 35 °C)	kW / COP	11,50/3,44	13,00/3,18	11,50/3,44	13,00/3,18	
Heating capacity / COP (A +2 °C, W 55 °C)	kW / COP	9,20/2,25	10,00/2,24	9,20/2,25	10,00/2,24	
Heating capacity / COP (A -7 °C, W 35 °C)	kW / COP	10,10/2,74	11,70/2,61	10,10/2,74	11,70/2,61	
Heating capacity / COP (A -7 °C, W 55 °C)	kW / COP	8,40/1,97	9,10/1,85	8,40/1,97	9,10/1,85	
Cooling capacity / EER (A 35 °C, W 7 °C)	kW / EER	10,70/2,68	12,20/2,68	10,70/2,68	12,20/2,68	
Cooling capacity / EER (A 35 °C, W 18 °C)	kW / EER	10,70/3,92	13,00/3,80	10,70/3,92	13,00/3,80	
Heating average climate (W 35 °C / W 55 °C)	Seasonal energy efficiency	SCOP (η <sub>s</sub> %)	4,58/3,33(180/130)	4,46/3,40(176/133)	4,58/3,33(180/130)	4,46/3,40(176/133)
	Energy class <sup>1)</sup>	A+++ to D	A+++/A++	A+++/A++	A+++/A++	A+++/A++
Heating warm climate (W 35 °C / W 55 °C)	Seasonal energy efficiency	SCOP (η <sub>s</sub> %)	6,47/4,34(256/171)	6,20/4,30(245/169)	6,47/4,34(256/171)	6,20/4,30(245/169)
	Energy class <sup>1)</sup>	A+++ to D	A+++/A+++	A+++/A+++	A+++/A+++	A+++/A+++
Heating cold climate (W 35 °C / W 55 °C)	Seasonal energy efficiency	SCOP (η <sub>s</sub> %)	4,31/3,26(169/127)	4,28/3,10(168/121)	4,31/3,26(169/127)	4,28/3,10(168/121)
	Energy class <sup>1)</sup>	A+++ to D	A++/A++	A++/A+	A++/A++	A++/A+
<b>Indoor unit</b>		<b>WH-ADC0912K6E53</b>	<b>WH-ADC16K6E53</b>	<b>WH-ADC0912K6E5AN3</b>	<b>WH-ADC16K6E5AN3</b>	
Sound pressure	Heat / Cool	dB(A)	33/33	33/33	33/33	
Dimension	H x W x D	mm	2036 x 599 x 602	2036 x 599 x 602	2036 x 599 x 602	
Net weight		kg	119	119	120	
Water pipe connector		Inch	R 1½	R 1½	R 1½	
A class pump	Number of speeds		Variable speed	Variable speed	Variable speed	
	Input power	W	145	145	145	
Heating water flow (ΔT=5 K, 35 °C)		L/min	34,4	34,4	45,8	
Water volume		L	260	260	260	
Maximum DHW temperature		°C	65	65	65	
Material inside tank			Stainless steel	Stainless steel	Stainless steel	
Tapping profile according EN16147			L	L	L	
DHW tank ERP efficiency average / warm / cold <sup>2)</sup>	A+ to F	A+/A/A	A+/A/A	A+/A/A	A+/A/A	
DHW tank ERP average climate η / COPdHW	η <sub>wh</sub> % / COPdHW	100/2,50	100/2,50	100/2,50	100/2,50	
DHW tank ERP warm climate η / COPdHW	η <sub>wh</sub> % / COPdHW	116/2,90	116/2,90	116/2,90	116/2,90	
DHW tank ERP cold climate η / COPdHW	η <sub>wh</sub> % / COPdHW	80/2,00	80/2,00	80/2,00	80/2,00	
<b>Outdoor unit</b>		<b>WH-UDZ12KE5</b>	<b>WH-UDZ16KE5</b>	<b>WH-UDZ12KE5</b>	<b>WH-UDZ16KE5</b>	
Sound power <sup>3)</sup>	Heat	dB(A)	65	65	65	
Dimension / Net weight	H x W x D	mm / kg	1340 x 900 x 320/88	1340 x 900 x 320/88	1340 x 900 x 320/88	
Refrigerant (R32) / CO <sub>2</sub> Eq.		kg / T	1,6/1,080	1,6/1,080	1,6/1,080	
Piping diameter	Liquid / Gas	Inch (mm)	1/4(6,35)/1/2(12,70)	1/4(6,35)/5/8(15,88)	1/4(6,35)/1/2(12,70)	
Pipe length range / Elevation difference (in / out)		m / m	3~30(3~50) <sup>4)</sup> /20(30) <sup>4)</sup>	3~30(3~50) <sup>4)</sup> /20(30) <sup>4)</sup>	3~30(3~50) <sup>4)</sup> /20(30) <sup>4)</sup>	
Pre-charged pipe length / Additional gas amount		m / g/m	10/30	10/30	10/30	
Operating range - outdoor ambient	Heat	°C	-25 ~ +35	-25 ~ +35	-25 ~ +35	
	Cool	°C	+10 ~ +43	+10 ~ +43	+10 ~ +43	
Water outlet	Heat / Cool	°C	20 ~ 60/5 ~ 20	20 ~ 60/5 ~ 20	20 ~ 60/5 ~ 20	
<b>Electrical information</b>		<b>WH-ADC0912K6E53</b>	<b>WH-ADC16K6E53</b>	<b>WH-ADC0912K6E5AN3</b>	<b>WH-ADC16K6E5AN3</b>	
Electric backup heater		kW	6,00	6,00	6,00	
Recommended fuse <sup>5)</sup>		A	30/30	30/30	30/30	
Recommended minimum cable size, supply 1 / 2 <sup>5)</sup>		mm <sup>2</sup>	3x4,0/3x4,0	3x4,0/3x4,0	3x4,0/3x4,0	

1) Scale from A+++ to D. 2) Scale from A+ to F. 3) Sound power in accordance to 811/2013, 813/2013 and EN 12102-1:2017 at +7 °C. 4) Operation range down to -25 °C in heating with 3-40 m pipe length range, operation range down to -15 °C in heating with 3-50 m pipe length range. 5) Check local regulations. \*EER and COP calculation is based in accordance to EN 14511. \*\*This product is designed to comply with the European drinking water standard (EU) 2020/2184. The lifespan of the product is not guaranteed in the case of the use of groundwater, such as spring water or well water, the use of tap water when salt or other impurities are contained, nor in areas of acidic water quality. Maintenance and warranty costs related to these cases are the customer's responsibility.

### Accessories

**CZ-RTW1** Optional remote controller for 2 zone control. K and L Series

**CZ-TAW1B** Optional Wi-Fi or WLAN adapter for smart control via Comfort Cloud App and/or remote maintenance via Aquarea Service Cloud

### Accessories

**CZ-TAW1-CBL** 10 m extension cable for CZ-TAW1B

**CZ-NS5P** PCB for advanced functions

**PAW-A2W-RTWIRED** Room thermostat

**PAW-A2W-RTWIREDLESS** Wireless LCD room thermostat



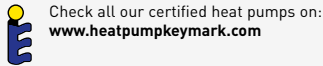

## Aquarea High Performance All in One 185 L K Series. Single phase 2 zones - R32

**Energy efficiency:** A+++ heating at 35 °C / A+ DHW / COP up to 5.33 / DHW COP up to 3.50 / "A"-rated variable-speed pump / Stainless steel DHW tank with U-Vacua™.

**Flexibility:** Built-in 2-zone kit / 599 x 602 footprint / Built-in magnetic water filter.

**Comfort:** Operation without backup heater down to -25 °C / 60 °C flow temperature at -10 °C.

**Control:** Optimised user interface and improved features (2 zone control, bivalent control).

**Connectivity:** Optional Wi-Fi and BMS integration.

		Single phase [power to indoor]				
Kit		KIT-ADC03K3E5B	KIT-ADC05K3E5B	KIT-ADC07K3E5B	KIT-ADC09K3E5B	
Heating capacity / COP (A +7 °C, W 35 °C)	kW / COP	3,20/5,33	5,00/5,10	7,00/4,86	9,00/4,55	
Heating capacity / COP (A +7 °C, W 55 °C)	kW / COP	3,20/2,81	5,00/3,03	7,00/2,92	8,90/2,93	
Heating capacity / COP (A +2 °C, W 35 °C)	kW / COP	3,20/3,64	5,00/3,57	6,85/3,43	7,00/3,40	
Heating capacity / COP (A +2 °C, W 55 °C)	kW / COP	3,20/2,19	5,00/2,29	6,25/2,23	6,30/2,18	
Heating capacity / COP (A -7 °C, W 35 °C)	kW / COP	3,30/2,80	5,00/2,79	5,75/2,95	6,25/2,84	
Heating capacity / COP (A -7 °C, W 55 °C)	kW / COP	3,20/1,79	5,00/1,89	5,35/1,98	5,90/1,93	
Cooling capacity / EER (A 35 °C, W 7 °C)	kW / EER	3,20/3,52	5,00/3,05	6,70/3,03	8,20/2,72	
Cooling capacity / EER (A 35 °C, W 18 °C)	kW / EER	3,20/4,71	5,00/4,90	6,70/4,72	9,00/4,18	
Heating average climate (W 35 °C / W 55 °C)	Seasonal energy efficiency	SCOP (η <sub>s</sub> %)	5,07/3,47(200/136)	5,12/3,63(202/142)	4,90/3,62(193/142)	4,44/3,41(175/133)
	Energy class <sup>1)</sup>		A+++ to D	A+++/A++	A+++/A++	A+++/A++
Heating warm climate (W 35 °C / W 55 °C)	Seasonal energy efficiency	SCOP (η <sub>s</sub> %)	6,20/4,20(245/165)	6,00/4,20(237/165)	5,75/4,07(227/160)	5,75/4,07(227/160)
	Energy class <sup>1)</sup>		A+++ to D	A+++/A+++	A+++/A+++	A+++/A+++
Heating cold climate (W 35 °C / W 55 °C)	Seasonal energy efficiency	SCOP (η <sub>s</sub> %)	4,00/2,83(157/110)	4,08/2,95(160/115)	4,18/2,98(164/116)	4,18/2,98(164/116)
	Energy class <sup>1)</sup>		A+++ to D	A++/A+	A++/A+	A++/A+
<b>Indoor unit</b>		<b>WH-ADC0309K3E5B</b>	<b>WH-ADC0309K3E5B</b>	<b>WH-ADC0309K3E5B</b>	<b>WH-ADC0309K3E5B</b>	
Sound pressure	Heat / Cool	dB(A)	28/28	28/28	28/28	
Dimension	H x W x D	mm	1642 x 599 x 602	1642 x 599 x 602	1642 x 599 x 602	
Net weight		kg	109	109	109	
Water pipe connector		Inch	R 1½	R 1½	R 1½	
A class pump	Number of speeds		Variable speed	Variable speed	Variable speed	
	Input power (Min/Max)	W	30/120	30/120	30/120	
Heating water flow (ΔT=5 K, 35 °C)		L/min	9,2	14,3	20,1	
Water volume		L	185	185	185	
Maximum DHW temperature		°C	65	65	65	
Material inside tank			Stainless steel	Stainless steel	Stainless steel	
Tapping profile according EN16147			L	L	L	
DHW tank ERP efficiency average / warm / cold <sup>2)</sup>		A+ to F	A+/A++/A	A+/A++/A	A+/A++/A	
DHW tank ERP average climate η / COP <sub>DHW</sub>	η <sub>wh</sub> % / COP <sub>DHW</sub>		128/3,20	140/3,50	140/3,50	
DHW tank ERP warm climate η / COP <sub>DHW</sub>	η <sub>wh</sub> % / COP <sub>DHW</sub>		154/3,86	160/4,00	160/4,00	
DHW tank ERP cold climate η / COP <sub>DHW</sub>	η <sub>wh</sub> % / COP <sub>DHW</sub>		99/2,48	112/2,80	112/2,80	
<b>Outdoor unit</b>		<b>WH-UDZ03KE5</b>	<b>WH-UDZ05KE5</b>	<b>WH-UDZ07KE5</b>	<b>WH-UDZ09KE5</b>	
Sound power <sup>3)</sup>	Heat	dB(A)	55	55	56	
Dimension / Net weight	H x W x D	mm / kg	622 x 824 x 298/37	795 x 875 x 380/55	795 x 875 x 380/55	
Refrigerant (R32) / CO <sub>2</sub> Eq.		kg / T	0,9/0,608	1,3/0,878	1,3/0,878	
Piping diameter	Liquid / Gas	Inch (mm)	1/4(6,35)/1/2(12,70)	1/4(6,35)/5/8(15,88)	1/4(6,35)/5/8(15,88)	
Pipe length range / Elevation difference (in / out)		m / m	3~25/20	3~40(3~50) <sup>4)</sup> /30	3~40(3~50) <sup>4)</sup> /30	
Pre-charged pipe length / Additional gas amount		m / g/m	10/20	10/25	10/25	
Operating range - outdoor ambient	Heat	°C	-20~+35	-25~+35	-25~+35	
	Cool	°C	+10~+43	+10~+43	+10~+43	
Water outlet	Heat / Cool	°C	20~60/5~20	20~60/5~20	20~60/5~20	
<b>Electrical information</b>		<b>WH-ADC0309K3E5B</b>	<b>WH-ADC0309K3E5B</b>	<b>WH-ADC0309K3E5B</b>	<b>WH-ADC0309K3E5B</b>	
Electric backup heater		kW	3,00	3,00	3,00	
Recommended fuse <sup>5)</sup>		A	16/16	16/16	25/16	
Recommended minimum cable size, supply 1 / 2 <sup>5)</sup>		mm <sup>2</sup>	3x1,5/3x1,5	3x1,5/3x1,5	3x2,5/3x1,5	

1) Scale from A+++ to D. 2) Scale from A+ to F. 3) Sound power in accordance to 811/2013, 813/2013 and EN 12102-1:2017 at +7 °C. 4) Operation range down to -25 °C in heating with 3~40 m pipe length range, operation range down to -15 °C in heating with 3~50 m pipe length range. 5) Check local regulations. \*EER and COP calculation is based in accordance to EN 14511. \*\*This product is designed to comply with the European drinking water standard [EU] 2020/2184. The lifespan of the product is not guaranteed in the case of the use of groundwater, such as spring water or well water, the use of tap water when salt or other impurities are contained, nor in areas of acidic water quality. Maintenance and warranty costs related to these cases are the customer's responsibility.

### Accessories

<b>CZ-RTW1</b>	Optional remote controller for 2 zone control. K and L Series
<b>CZ-TAW1B</b>	Optional Wi-Fi or WLAN adapter for smart control via Comfort Cloud App and/or remote maintenance via Aquarea Service Cloud

### Accessories

<b>CZ-TAW1-CBL</b>	10 m extension cable for CZ-TAW1B
<b>CZ-NS5P</b>	PCB for advanced functions
<b>PAW-A2W-RTWIRED</b>	Room thermostat
<b>PAW-A2W-RTWIREDLESS</b>	Wireless LCD room thermostat



## Aquarea High Performance All in One 185 L K Series. Three phase - R32

**Energy efficiency:** A+++ heating at 35 °C / A DHW / "A"-rated variable-speed pump / Stainless steel DHW tank with U-Vacua™.

**Flexibility:** 599 x 602 footprint / Built-in magnetic water filter.

**Comfort:** Operation without backup heater down to -25 °C / 60 °C flow temperature at -10 °C.

**Control:** Optimised user interface and improved features (2 zone control, bivalent control).

**Connectivity:** Optional Wi-Fi and BMS integration.

Check all our certified heat pumps on:  
[www.heatpumpkeymark.com](http://www.heatpumpkeymark.com)



Optional

Three phase [power to indoor]

Kit			KIT-ADC09K9E8	KIT-ADC12K9E8	KIT-ADC16K9E8
Heating capacity / COP (A +7 °C, W 35 °C)	kW / COP		9,00/4,90	12,10/4,78	16,00/4,31
Heating capacity / COP (A +7 °C, W 55 °C)	kW / COP		9,00/2,97	12,00/2,96	14,70/2,72
Heating capacity / COP (A +2 °C, W 35 °C)	kW / COP		9,00/3,63	11,50/3,44	13,20/3,28
Heating capacity / COP (A +2 °C, W 55 °C)	kW / COP		9,00/2,26	9,20/2,25	10,00/2,21
Heating capacity / COP (A -7 °C, W 35 °C)	kW / COP		9,00/2,88	10,10/2,74	11,60/2,57
Heating capacity / COP (A -7 °C, W 55 °C)	kW / COP		8,10/2,07	8,40/1,97	9,10/1,85
Cooling capacity / EER (A 35 °C, W 7 °C)	kW / EER		8,80/3,11	10,70/2,68	13,40/2,64
Cooling capacity / EER (A 35 °C, W 18 °C)	kW / EER		8,80/4,63	10,70/3,92	15,50/3,60
Heating average climate (W 35 °C / W 55 °C)	Seasonal energy efficiency	SCOP (η <sub>s</sub> %)	4,96/3,57(195/140)	4,58/3,33(180/130)	4,46/3,40(176/133)
	Energy class <sup>1)</sup>		A+++ / A++	A+++ / A++	A+++ / A++
Heating warm climate (W 35 °C / W 55 °C)	Seasonal energy efficiency	SCOP (η <sub>s</sub> %)	6,47/4,34(256/171)	6,47/4,34(256/171)	6,20/4,30(245/169)
	Energy class <sup>1)</sup>		A+++ / A+++	A+++ / A+++	A+++ / A+++
Heating cold climate (W 35 °C / W 55 °C)	Seasonal energy efficiency	SCOP (η <sub>s</sub> %)	4,31/3,26(169/127)	4,31/3,26(169/127)	4,28/3,10(168/121)
	Energy class <sup>1)</sup>		A++ / A++	A++ / A++	A++ / A+
<b>Indoor unit</b>			<b>WH-ADC0912K9E8</b>	<b>WH-ADC0912K9E8</b>	<b>WH-ADC16K9E8</b>
Sound pressure	Heat / Cool	dB(A)	33/33	33/33	33/33
Dimension	H x W x D	mm	1642 x 599 x 602	1642 x 599 x 602	1642 x 599 x 602
Net weight		kg	102	102	103
Water pipe connector		Inch	R 1¼	R 1¼	R 1¼
A class pump	Number of speeds		Variable speed	Variable speed	Variable speed
	Input power	W	145	145	145
Heating water flow (ΔT=5 K, 35 °C)		L/min	25,8	34,4	45,9
Water volume		L	185	185	185
Maximum DHW temperature		°C	65	65	65
Material inside tank			Stainless steel	Stainless steel	Stainless steel
Tapping profile according EN16147			L	L	L
DHW tank ERP efficiency average / warm / cold <sup>2)</sup>		A+ to F	A/A+/A	A/A+/A	A/A+/A
DHW tank ERP average climate η / COPdHW		η <sub>wh</sub> % / COPdHW	100/2,50	100/2,50	96/2,40
DHW tank ERP warm climate η / COPdHW		η <sub>wh</sub> % / COPdHW	116/2,90	116/2,90	115/2,88
DHW tank ERP cold climate η / COPdHW		η <sub>wh</sub> % / COPdHW	80/2,00	80/2,00	76/1,90
<b>Outdoor unit</b>			<b>WH-UDZ09KE8</b>	<b>WH-UDZ12KE8</b>	<b>WH-UDZ16KE8</b>
Sound power <sup>3)</sup>	Heat	dB(A)	65	65	65
Dimension / Net weight	H x W x D	mm / kg	1340 x 900 x 320 / 90	1340 x 900 x 320 / 90	1340 x 900 x 320 / 103
Refrigerant (R32) / CO <sub>2</sub> Eq.		kg / T	1,60 / 1,080	1,60 / 1,080	1,83 / 1,235
Piping diameter	Liquid / Gas	Inch (mm)	1/4 (6,35) / 1/2 (12,70)	1/4 (6,35) / 1/2 (12,70)	1/4 (6,35) / 1/2 (12,70)
Pipe length range / Elevation difference (in / out)		m / m	3 - 30 / 20	3 - 30 / 20	3 - 30 / 20
Pre-charged pipe length / Additional gas amount		m / g/m	10 / 30	10 / 30	10 / 30
Operating range - outdoor ambient	Heat	°C	-25 ~ +35	-25 ~ +35	-25 ~ +35
	Cool	°C	+10 ~ +43	+10 ~ +43	+10 ~ +43
Water outlet <sup>4)</sup>	Heat / Cool	°C	20 ~ 60 / 5 ~ 20	20 ~ 60 / 5 ~ 20	20 ~ 60 / 5 ~ 20
<b>Electrical information</b>			<b>WH-ADC0912K9E8</b>	<b>WH-ADC0912K9E8</b>	<b>WH-ADC16K9E8</b>
Electric backup heater		kW	9,00	9,00	9,00
Recommended fuse <sup>5)</sup>		A	20/20	20/20	20/20
Recommended minimum cable size, supply 1 / 2 <sup>5)</sup>		mm <sup>2</sup>	5x1,5/5x1,5	5x1,5/5x1,5	5x2,5/5x1,5

1) Scale from A+++ to D. 2) Scale from A+ to F. 3) Sound power level in accordance to EN 12102 under conditions of the EN14825. 4) Between outdoor ambient -10 °C and -15 °C, the water outlet temperature gradually decreases from 60 °C to 55 °C. 5) Check local regulations. \*EER and COP calculation is based in accordance to EN 14511. \*\*This product is designed to comply with the European drinking water standard (EU) 2020/2184. The lifespan of the product is not guaranteed in the case of the use of groundwater, such as spring water or well water, the use of tap water when salt or other impurities are contained, nor in areas of acidic water quality. Maintenance and warranty costs related to these cases are the customer's responsibility.

### Accessories

<b>CZ-RTW1</b>	Optional remote controller for 2 zone control. K and L Series
<b>CZ-TAW1B</b>	Optional Wi-Fi or WLAN adapter for smart control via Comfort Cloud App and/or remote maintenance via Aquarea Service Cloud

### Accessories

<b>CZ-TAW1-CBL</b>	10 m extension cable for CZ-TAW1B
<b>CZ-NS5P</b>	PCB for advanced functions
<b>PAW-A2W-RTWIRED</b>	Room thermostat
<b>PAW-A2W-RTWIRELESS</b>	Wireless LCD room thermostat



Check all our certified heat pumps on:  
[www.heatpumpkeymark.com](http://www.heatpumpkeymark.com)

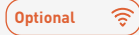

**Aquarea High Performance All in One 185 L K Series.**  
**Three phase with Electrical Anode - R32**

**Energy efficiency:** A+++ heating at 35 °C / A DHW / "A"-rated variable-speed pump / Stainless steel DHW tank with U-Vacua™.  
**Flexibility:** Suitable for harsh-water installations / 599 x 602 footprint / Built-in magnetic water filter.  
**Comfort:** Operation without backup heater down to -25 °C / 60 °C flow temperature at -10 °C.  
**Control:** Optimised user interface and improved features (2 zone control, bivalent control).  
**Connectivity:** Optional Wi-Fi and BMS integration.

Three phase (power to indoor)

Kit	KIT-ADC09K9E8AN			KIT-ADC12K9E8AN			KIT-ADC16K9E8AN					
Heating capacity / COP (A +7 °C, W 35 °C)	kW / COP			9,00/4,90			12,10/4,78			16,00/4,31		
Heating capacity / COP (A +7 °C, W 55 °C)	kW / COP			9,00/2,97			12,00/2,96			14,70/2,72		
Heating capacity / COP (A +2 °C, W 35 °C)	kW / COP			9,00/3,63			11,50/3,44			13,20/3,28		
Heating capacity / COP (A +2 °C, W 55 °C)	kW / COP			9,00/2,26			9,20/2,25			10,00/2,21		
Heating capacity / COP (A -7 °C, W 35 °C)	kW / COP			9,00/2,88			10,10/2,74			11,60/2,57		
Heating capacity / COP (A -7 °C, W 55 °C)	kW / COP			8,10/2,07			8,40/1,97			9,10/1,85		
Cooling capacity / EER (A 35 °C, W 7 °C)	kW / EER			8,80/3,11			10,70/2,68			13,40/2,64		
Cooling capacity / EER (A 35 °C, W 18 °C)	kW / EER			8,80/4,63			10,70/3,92			15,50/3,60		
Heating average climate (W 35 °C / W 55 °C)	Seasonal energy efficiency	SCOP (η <sub>s</sub> %)	4,96/3,57(195/140)			4,58/3,33(180/130)			4,46/3,40(176/133)			
	Energy class <sup>1)</sup>		A+++ to D			A+++/A++			A+++/A++			
Heating warm climate (W 35 °C / W 55 °C)	Seasonal energy efficiency	SCOP (η <sub>s</sub> %)	6,47/4,34(256/171)			6,47/4,34(256/171)			6,20/4,30(245/169)			
	Energy class <sup>1)</sup>		A+++ to D			A+++/A+++			A+++/A+++			
Heating cold climate (W 35 °C / W 55 °C)	Seasonal energy efficiency	SCOP (η <sub>s</sub> %)	4,31/3,26(169/127)			4,31/3,26(169/127)			4,28/3,10(168/121)			
	Energy class <sup>1)</sup>		A+++ to D			A++/A++			A++/A+			
<b>Indoor unit</b>			<b>WH-ADC0912K9E8AN</b>			<b>WH-ADC0912K9E8AN</b>			<b>WH-ADC16K9E8AN</b>			
Sound pressure	Heat / Cool	dB(A)	33/33			33/33			33/33			
Dimension	H x W x D	mm	1642 x 599 x 602			1642 x 599 x 602			1642 x 599 x 602			
Net weight		kg	102			102			103			
Water pipe connector		Inch	R 1½			R 1½			R 1½			
A class pump	Number of speeds		Variable speed			Variable speed			Variable speed			
	Input power	W	145			145			145			
Heating water flow (ΔT=5 K, 35 °C)		L/min	25,8			34,4			45,9			
Water volume		L	185			185			185			
Maximum DHW temperature		°C	65			65			65			
Material inside tank			Stainless steel			Stainless steel			Stainless steel			
Tapping profile according EN16147			L			L			L			
DHW tank ERP efficiency average / warm / cold <sup>2)</sup>		A+ to F	A/A+/A			A/A+/A			A/A+/A			
DHW tank ERP average climate η / COP <sub>DHW</sub>	η <sub>wh</sub> % / COP <sub>DHW</sub>		100/2,50			100/2,50			96/2,40			
DHW tank ERP warm climate η / COP <sub>DHW</sub>	η <sub>wh</sub> % / COP <sub>DHW</sub>		116/2,90			116/2,90			115/2,88			
DHW tank ERP cold climate η / COP <sub>DHW</sub>	η <sub>wh</sub> % / COP <sub>DHW</sub>		80/2,00			80/2,00			76/1,90			
<b>Outdoor unit</b>			<b>WH-UDZ09KE8</b>			<b>WH-UDZ12KE8</b>			<b>WH-UDZ16KE8</b>			
Sound power <sup>3)</sup>	Heat	dB(A)	65			65			65			
Dimension / Net weight	H x W x D	mm / kg	1340 x 900 x 320 / 90			1340 x 900 x 320 / 90			1340 x 900 x 320 / 103			
Refrigerant (R32) / CO <sub>2</sub> Eq.		kg / T	1,60/1,080			1,60/1,080			1,83/1,235			
Piping diameter	Liquid / Gas	Inch (mm)	1/4(6,35)/1/2(12,70)			1/4(6,35)/1/2(12,70)			1/4(6,35)/1/2(12,70)			
Pipe length range / Elevation difference (in / out)		m / m	3~30/20			3~30/20			3~30/20			
Pre-charged pipe length / Additional gas amount		m / g/m	10/30			10/30			10/30			
Operating range - outdoor ambient	Heat	°C	-25~+35			-25~+35			-25~+35			
	Cool	°C	+10~+43			+10~+43			+10~+43			
Water outlet <sup>4)</sup>	Heat / Cool	°C	20~60/5~20			20~60/5~20			20~60/5~20			
<b>Electrical information</b>			<b>WH-ADC0912K9E8AN3</b>			<b>WH-ADC0912K9E8AN3</b>			<b>WH-ADC16K9E8AN3</b>			
Electric backup heater		kW	9,00			9,00			9,00			
Recommended fuse <sup>5)</sup>		A	20/20			20/20			20/20			
Recommended minimum cable size, supply 1 / 2 <sup>5)</sup>		mm <sup>2</sup>	5x1,5/5x1,5			5x1,5/5x1,5			5x2,5/5x1,5			

1) Scale from A+++ to D. 2) Scale from A+ to F. 3) Sound power level in accordance to EN 12102 under conditions of the EN14825. 4) Between outdoor ambient -10 °C and -15 °C, the water outlet temperature gradually decreases from 60 °C to 55 °C. 5) Check local regulations. \*EER and COP calculation is based in accordance to EN 14511. \*\*This product is designed to comply with the European drinking water standard (EU) 2020/2184. The lifespan of the product is not guaranteed in the case of the use of groundwater, such as spring water or well water, the use of tap water when salt or other impurities are contained, nor in areas of acidic water quality. Maintenance and warranty costs related to these cases are the customer's responsibility.

Accessories	
<b>CZ-RTW1</b>	Optional remote controller for 2 zone control. K and L Series
<b>CZ-TAW1B</b>	Optional Wi-Fi or WLAN adapter for smart control via Comfort Cloud App and/or remote maintenance via Aquarea Service Cloud

Accessories	
<b>CZ-TAW1-CBL</b>	10 m extension cable for CZ-TAW1B
<b>CZ-NS5P</b>	PCB for advanced functions
<b>PAW-A2W-RTWIRED</b>	Room thermostat
<b>PAW-A2W-RTWIRELESS</b>	Wireless LCD room thermostat



## Aquarea High Performance All in One 260 L K Series. Three phase - R32

**Energy efficiency:** A+++ heating at 35 °C / A+ DHW / "A"-rated variable-speed pump / Stainless steel DHW tank with U-Vacua™.

**Flexibility:** 599 x 602 footprint / Built-in magnetic water filter.

**Comfort:** Operation without backup heater down to -25 °C / 60 °C flow temperature at -10 °C.

**Control:** Optimised user interface and improved features (2 zone control, bivalent control).

**Connectivity:** Optional Wi-Fi and BMS integration.

Check all our certified heat pumps on:  
[www.heatpumpkeymark.com](http://www.heatpumpkeymark.com)

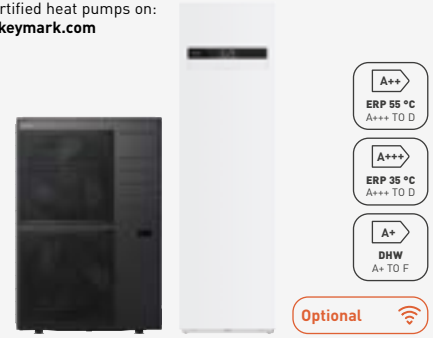

Three phase (power to indoor)

Kit			KIT-ADC09K9E83	KIT-ADC12K9E83	KIT-ADC16K9E83
Heating capacity / COP (A +7 °C, W 35 °C)	kW / COP		9,00/4,90	12,10/4,78	16,00/4,31
Heating capacity / COP (A +7 °C, W 55 °C)	kW / COP		9,00/2,97	12,00/2,96	14,70/2,72
Heating capacity / COP (A +2 °C, W 35 °C)	kW / COP		9,00/3,63	11,50/3,44	13,20/3,28
Heating capacity / COP (A +2 °C, W 55 °C)	kW / COP		9,00/2,26	9,20/2,25	10,00/2,21
Heating capacity / COP (A -7 °C, W 35 °C)	kW / COP		9,00/2,88	10,10/2,74	11,60/2,57
Heating capacity / COP (A -7 °C, W 55 °C)	kW / COP		8,10/2,07	8,40/1,97	9,10/1,85
Cooling capacity / EER (A 35 °C, W 7 °C)	kW / EER		8,80/3,11	10,70/2,68	13,40/2,64
Cooling capacity / EER (A 35 °C, W 18 °C)	kW / EER		8,80/4,63	10,70/3,92	15,50/3,60
Heating average climate (W 35 °C / W 55 °C)	Seasonal energy efficiency	SCOP (η <sub>s</sub> %)	4,96/3,57(195/140)	4,58/3,33(180/130)	4,46/3,40(176/133)
	Energy class <sup>1)</sup>	A+++ to D	A+++ / A++	A+++ / A++	A+++ / A++
Heating warm climate (W 35 °C / W 55 °C)	Seasonal energy efficiency	SCOP (η <sub>s</sub> %)	6,47/4,34(256/171)	6,47/4,34(256/171)	6,20/4,30(245/169)
	Energy class <sup>1)</sup>	A+++ to D	A+++ / A+++	A+++ / A+++	A+++ / A+++
Heating cold climate (W 35 °C / W 55 °C)	Seasonal energy efficiency	SCOP (η <sub>s</sub> %)	4,31/3,26(169/127)	4,31/3,26(169/127)	4,28/3,10(168/121)
	Energy class <sup>1)</sup>	A+++ to D	A++ / A++	A++ / A++	A++ / A+
<b>Indoor unit</b>			<b>WH-ADC0912K9E83</b>	<b>WH-ADC0912K9E83</b>	<b>WH-ADC16K9E83</b>
Sound pressure	Heat / Cool	dB(A)	33/33	33/33	33/33
Dimension	H x W x D	mm	2036 x 599 x 602	2036 x 599 x 602	2036 x 599 x 602
Net weight		kg	119	119	120
Water pipe connector		Inch	R 1¼	R 1¼	R 1¼
A class pump	Number of speeds		Variable speed	Variable speed	Variable speed
	Input power	W	145	145	145
Heating water flow (ΔT=5 K, 35 °C)		L/min	25,8	34,4	46,0
Water volume		L	260	260	260
Maximum DHW temperature		°C	65	65	65
Material inside tank			Stainless steel	Stainless steel	Stainless steel
Tapping profile according EN16147			XL	XL	XL
DHW tank ERP efficiency average / warm / cold <sup>2)</sup>	A+ to F	A+ / A+ / A	A+ / A+ / A	A+ / A+ / A	A+ / A+ / A
DHW tank ERP average climate η / COPdHW	η <sub>wh</sub> % / COPdHW		123/3,08	123/3,08	98/2,45
DHW tank ERP warm climate η / COPdHW	η <sub>wh</sub> % / COPdHW		134/3,35	134/3,35	123/3,08
DHW tank ERP cold climate η / COPdHW	η <sub>wh</sub> % / COPdHW		94/2,35	94/2,35	80/2,00
<b>Outdoor unit</b>			<b>WH-UDZ09KE8</b>	<b>WH-UDZ12KE8</b>	<b>WH-UDZ16KE8</b>
Sound power <sup>3)</sup>	Heat	dB(A)	65	65	65
Dimension / Net weight	H x W x D	mm / kg	1340 x 900 x 320 / 90	1340 x 900 x 320 / 90	1340 x 900 x 320 / 103
Refrigerant (R32) / CO <sub>2</sub> Eq.		kg / T	1,60 / 1,080	1,60 / 1,080	1,83 / 1,235
Piping diameter	Liquid / Gas	Inch (mm)	1/4 (6,35) / 1/2 (12,70)	1/4 (6,35) / 1/2 (12,70)	1/4 (6,35) / 1/2 (12,70)
Pipe length range / Elevation difference (in / out)		m / m	3 - 30 / 20	3 - 30 / 20	3 - 30 / 20
Pre-charged pipe length / Additional gas amount		m / g/m	10 / 30	10 / 30	10 / 30
Operating range - outdoor ambient	Heat	°C	-25 ~ +35	-25 ~ +35	-25 ~ +35
	Cool	°C	+10 ~ +43	+10 ~ +43	+10 ~ +43
Water outlet	Heat / Cool	°C	20 ~ 60 / 5 ~ 20	20 ~ 60 / 5 ~ 20	20 ~ 60 / 5 ~ 20
<b>Electrical information</b>			<b>WH-ADC0912K9E83</b>	<b>WH-ADC0912K9E83</b>	<b>WH-ADC16K9E83</b>
Electric backup heater		kW	9,00	9,00	9,00
Recommended fuse <sup>5)</sup>		A	20/20	20/20	20/20
Recommended minimum cable size, supply 1 / 2 <sup>5)</sup>		mm <sup>2</sup>	5x1,5/5x1,5	5x1,5/5x1,5	5x2,5/5x1,5

1) Scale from A+++ to D. 2) Scale from A+ to F. 3) Sound power in accordance to 811/2013, 813/2013 and EN 12102-1:2017 at +7 °C. 4) Operation range down to -25 °C in heating with 3-40 m pipe length range, operation range down to -15 °C in heating with 3-50 m pipe length range. 5) Check local regulations. \*EER and COP calculation is based in accordance to EN 14511. \*\*This product is designed to comply with the European drinking water standard (EU) 2020/2184. The lifespan of the product is not guaranteed in the case of the use of groundwater, such as spring water or well water, the use of tap water when salt or other impurities are contained, nor in areas of acidic water quality. Maintenance and warranty costs related to these cases are the customer's responsibility.

### Accessories

<b>CZ-RTW1</b>	Optional remote controller for 2 zone control. K and L Series
<b>CZ-TAW1B</b>	Optional Wi-Fi or WLAN adapter for smart control via Comfort Cloud App and/or remote maintenance via Aquarea Service Cloud

### Accessories

<b>CZ-TAW1-CBL</b>	10 m extension cable for CZ-TAW1B
<b>CZ-NS5P</b>	PCB for advanced functions
<b>PAW-A2W-RTWIRED</b>	Room thermostat
<b>PAW-A2W-RTWIREDLESS</b>	Wireless LCD room thermostat



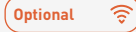
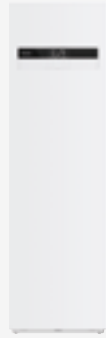
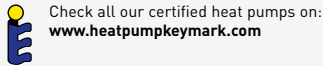

## Aquaarea High Performance All in One 260 L K Series. Three phase with Electrical Anode - R32

**Energy efficiency:** A+++ heating at 35 °C / A+ DHW / "A"-rated variable-speed pump / Stainless steel DHW tank with U-Vacua™.

**Flexibility:** Suitable for harsh-water installations / 599 x 602 footprint / Built-in magnetic water filter.

**Comfort:** Operation without backup heater down to -25 °C / 60 °C flow temperature at -10 °C.

**Control:** Optimised user interface and improved features (2 zone control, bivalent control).

**Connectivity:** Optional Wi-Fi and BMS integration.

		Three phase (power to indoor)			
Kit		KIT-ADC09K9E8AN3	KIT-ADC12K9E8AN3	KIT-ADC16K9E8AN3	
Heating capacity / COP (A +7 °C, W 35 °C)	kW / COP	9,00/4,90	12,10/4,78	16,00/4,31	
Heating capacity / COP (A +7 °C, W 55 °C)	kW / COP	9,00/2,97	12,00/2,96	14,70/2,72	
Heating capacity / COP (A +2 °C, W 35 °C)	kW / COP	9,00/3,63	11,50/3,44	13,20/3,28	
Heating capacity / COP (A +2 °C, W 55 °C)	kW / COP	9,00/2,26	9,20/2,25	10,00/2,21	
Heating capacity / COP (A -7 °C, W 35 °C)	kW / COP	9,00/2,88	10,10/2,74	11,60/2,57	
Heating capacity / COP (A -7 °C, W 55 °C)	kW / COP	8,10/2,07	8,40/1,97	9,10/1,85	
Cooling capacity / EER (A 35 °C, W 7 °C)	kW / EER	8,80/3,11	10,70/2,68	13,40/2,64	
Cooling capacity / EER (A 35 °C, W 18 °C)	kW / EER	8,80/4,63	10,70/3,92	15,50/3,60	
Heating average climate (W 35 °C / W 55 °C)	Seasonal energy efficiency	SCOP (η <sub>s</sub> %)	4,96/3,57(195/140)	4,58/3,33(180/130)	4,46/3,40(176/133)
	Energy class <sup>1)</sup>		A+++ to D	A+++/A++	A+++/A++
Heating warm climate (W 35 °C / W 55 °C)	Seasonal energy efficiency	SCOP (η <sub>s</sub> %)	6,47/4,34(256/171)	6,47/4,34(256/171)	6,20/4,30(245/169)
	Energy class <sup>1)</sup>		A+++ to D	A+++/A+++	A+++/A+++
Heating cold climate (W 35 °C / W 55 °C)	Seasonal energy efficiency	SCOP (η <sub>s</sub> %)	4,31/3,26(169/127)	4,31/3,26(169/127)	4,28/3,10(168/121)
	Energy class <sup>1)</sup>		A+++ to D	A++/A++	A++/A+
<b>Indoor unit</b>		<b>WH-ADC0912K9E8AN3</b>	<b>WH-ADC0912K9E8AN3</b>	<b>WH-ADC16K9E8AN3</b>	
Sound pressure	Heat / Cool	dB(A)	33/33	33/33	33/33
Dimension	H x W x D	mm	2036 x 599 x 602	2036 x 599 x 602	2036 x 599 x 602
Net weight		kg	119	119	120
Water pipe connector		Inch	R 1½	R 1½	R 1½
A class pump	Number of speeds		Variable speed	Variable speed	Variable speed
	Input power	W	145	145	145
Heating water flow (ΔT=5 K, 35 °C)		L/min	25,8	34,4	45,9
Water volume		L	260	260	260
Maximum DHW temperature		°C	65	65	65
Material inside tank			Stainless steel	Stainless steel	Stainless steel
Tapping profile according EN16147			XL	XL	XL
DHW tank ERP efficiency average / warm / cold <sup>2)</sup>		A+ to F	A+/A+/A	A+/A+/A	A+/A+/A
DHW tank ERP average climate η / COP <sub>DHW</sub>	η <sub>wh</sub> % / COP <sub>DHW</sub>		123/3,08	123/3,08	98/2,45
DHW tank ERP warm climate η / COP <sub>DHW</sub>	η <sub>wh</sub> % / COP <sub>DHW</sub>		134/3,35	134/3,35	123/3,08
DHW tank ERP cold climate η / COP <sub>DHW</sub>	η <sub>wh</sub> % / COP <sub>DHW</sub>		94/2,35	94/2,35	80/2,00
<b>Outdoor unit</b>		<b>WH-UDZ09KE8</b>	<b>WH-UDZ12KE8</b>	<b>WH-UDZ16KE8</b>	
Sound power <sup>3)</sup>	Heat	dB(A)	65	65	65
Dimension / Net weight	H x W x D	mm / kg	1340 x 900 x 320 / 90	1340 x 900 x 320 / 90	1340 x 900 x 320 / 103
Refrigerant (R32) / CO <sub>2</sub> Eq.		kg / T	1,60/1,080	1,60/1,080	1,83/1,235
Piping diameter	Liquid / Gas	Inch (mm)	1/4 (6,35) / 1/2 (12,70)	1/4 (6,35) / 1/2 (12,70)	1/4 (6,35) / 1/2 (12,70)
Pipe length range / Elevation difference (in / out)		m / m	3~30/20	3~30/20	3~30/20
Pre-charged pipe length / Additional gas amount		m / g/m	10/30	10/30	10/30
Operating range - outdoor ambient	Heat	°C	-25~+35	-25~+35	-25~+35
	Cool	°C	+10~+43	+10~+43	+10~+43
Water outlet	Heat / Cool	°C	20~60/5~20	20~60/5~20	20~60/5~20
<b>Electrical information</b>		<b>WH-ADC0912K9E8AN3</b>	<b>WH-ADC0912K9E8AN3</b>	<b>WH-ADC16K9E8AN3</b>	
Electric backup heater		kW	9,00	9,00	9,00
Recommended fuse <sup>5)</sup>		A	20/20	20/20	20/20
Recommended minimum cable size, supply 1 / 2 <sup>5)</sup>		mm <sup>2</sup>	5x1,5/5x1,5	5x1,5/5x1,5	5x2,5/5x1,5

1) Scale from A+++ to D. 2) Scale from A+ to F. 3) Sound power in accordance to 811/2013, 813/2013 and EN 12102-1:2017 at +7 °C. 4) Operation range down to -25 °C in heating with 3~40 m pipe length range, operation range down to -15 °C in heating with 3~50 m pipe length range. 5) Check local regulations. \*EER and COP calculation is based in accordance to EN 14511. \*\*This product is designed to comply with the European drinking water standard [EU] 2020/2184. The lifespan of the product is not guaranteed in the case of the use of groundwater, such as spring water or well water, the use of tap water when salt or other impurities are contained, nor in areas of acidic water quality. Maintenance and warranty costs related to these cases are the customer's responsibility.

Accessories	
<b>CZ-RTW1</b>	Optional remote controller for 2 zone control. K and L Series
<b>CZ-TAW1B</b>	Optional Wi-Fi or WLAN adapter for smart control via Comfort Cloud App and/or remote maintenance via Aquaarea Service Cloud

Accessories	
<b>CZ-TAW1-CBL</b>	10 m extension cable for CZ-TAW1B
<b>CZ-NS5P</b>	PCB for advanced functions
<b>PAW-A2W-RTWIRED</b>	Room thermostat
<b>PAW-A2W-RTWIRELESS</b>	Wireless LCD room thermostat



## Aquarea High Performance Bi-bloc K Series. Single phase - SDC - R32

**Energy efficiency:** A+++ heating at 35 °C / COP up to 5,33 / "A"-rated variable-speed pump.

**Flexibility:** Built-in magnetic water filter.

**Comfort:** Operation without backup heater down to -25 °C / 60 °C flow temperature at -10 °C.

**Control:** Optimised user interface and improved features (2 zone control, bivalent control).

**Connectivity:** Optional Wi-Fi and BMS integration.

Check all our certified heat pumps on:  
[www.heatpumpkeymark.com](http://www.heatpumpkeymark.com)



		Single phase (power to indoor)								
Kit 3 kW electric heater		KIT-WC03K3E5	KIT-WC05K3E5	KIT-WC07K3E5	KIT-WC09K3E5	—	—	—	—	
Kit 6 kW electric heater		KIT-WC03K6E5	KIT-WC05K6E5	KIT-WC07K6E5	KIT-WC09K6E5	KIT-WC12K6E5	KIT-WC16K6E5	—	—	
Heating capacity / COP (A +7 °C, W 35 °C)	kW / COP	3,20/5,33	5,00/5,10	7,00/4,86	9,00/4,55	12,10/4,78	16,00/4,31			
Heating capacity / COP (A +7 °C, W 55 °C)	kW / COP	3,20/2,81	5,00/3,03	7,00/2,92	8,90/2,93	12,00/2,96	14,70/2,72			
Heating capacity / COP (A +2 °C, W 35 °C)	kW / COP	3,20/3,64	5,00/3,57	6,85/3,43	7,00/3,40	11,50/3,44	13,00/3,18			
Heating capacity / COP (A +2 °C, W 55 °C)	kW / COP	3,20/2,19	5,00/2,29	6,25/2,23	6,30/2,18	9,20/2,25	10,00/2,24			
Heating capacity / COP (A -7 °C, W 35 °C)	kW / COP	3,30/2,80	5,00/2,79	5,75/2,95	6,25/2,84	10,10/2,74	11,70/2,61			
Heating capacity / COP (A -7 °C, W 55 °C)	kW / COP	3,20/1,79	5,00/1,89	5,35/1,98	5,90/1,93	8,40/1,97	9,10/1,85			
Cooling capacity / EER (A 35 °C, W 7 °C)	kW / EER	3,20/3,52	5,00/3,05	6,70/3,03	8,20/2,72	10,70/2,68	12,20/2,68			
Cooling capacity / EER (A 35 °C, W 18 °C)	kW / EER	3,20/4,71	5,00/4,90	6,70/4,72	9,00/4,18	10,70/3,92	13,00/3,80			
Heating average climate (W 35 °C / W 55 °C)	Seasonal energy efficiency	SCOP (η <sub>s</sub> %)	5,07/3,47(200/136)	5,12/3,63(202/142)	4,90/3,62(193/142)	4,44/3,41(175/133)	4,58/3,33(180/130)	4,46/3,40(176/133)		
	Energy class <sup>1)</sup>		A+++ / A++	A+++ / A++	A+++ / A++	A+++ / A++	A+++ / A++	A+++ / A++		
Heating warm climate (W 35 °C / W 55 °C)	Seasonal energy efficiency	SCOP (η <sub>s</sub> %)	6,20/4,20(245/165)	6,00/4,20(237/165)	5,75/4,07(227/160)	5,75/4,07(227/160)	6,47/4,34(256/171)	6,20/4,30(245/169)		
	Energy class <sup>1)</sup>		A+++ / A+++	A+++ / A+++	A+++ / A+++	A+++ / A+++	A+++ / A+++	A+++ / A+++		
Heating cold climate (W 35 °C / W 55 °C)	Seasonal energy efficiency	SCOP (η <sub>s</sub> %)	4,00/2,83(157/110)	4,08/2,95(160/115)	4,18/2,98(164/116)	4,18/2,98(164/116)	4,31/3,26(169/127)	4,28/3,10(168/121)		
	Energy class <sup>1)</sup>		A+++ / A+	A++ / A+	A++ / A+	A++ / A+	A++ / A++	A++ / A+		
<b>Indoor unit 3 kW electric heater</b>	<b>WH-</b>	<b>SDC0309K3E5</b>	<b>SDC0309K3E5</b>	<b>SDC0309K3E5</b>	<b>SDC0309K3E5</b>	—	—			
<b>Indoor unit 6 kW electric heater</b>	<b>WH-</b>	<b>SDC0309K6E5</b>	<b>SDC0309K6E5</b>	<b>SDC0309K6E5</b>	<b>SDC0309K6E5</b>	<b>SDC12K6E5</b>	<b>SDC16K6E5</b>			
Sound pressure	Heat / Cool	dB(A)	28/28	28/28	30/30	30/31	33/33	33/33		
Dimension	HxWxD	mm	892x500x348	892x500x348	892x500x348	892x500x348	892x500x348	892x500x348		
Net weight 3 kW / 6 kW		kg	40/41	40/41	40/41	40/41	41	41		
Water pipe connector		Inch	R 1¼	R 1¼	R 1¼	R 1¼	R 1¼	R 1¼		
A class pump	Number of speeds		Variable speed	Variable speed	Variable speed	Variable speed	Variable speed	Variable speed		
	Input power	W	145	145	145	145	145	145		
Heating water flow (ΔT=5 K, 35 °C)		L/min	9,2	14,3	20,1	25,8	34,4	45,8		
<b>Outdoor unit</b>			<b>WH-UDZ03KE5</b>	<b>WH-UDZ05KE5</b>	<b>WH-UDZ07KE5</b>	<b>WH-UDZ09KE5</b>	<b>WH-UDZ12KE5</b>	<b>WH-UDZ16KE5</b>		
Sound power <sup>2)</sup>	Heat	dB(A)	55	55	56	56	65	65		
Dimension	HxWxD	mm	622x824x298	795x875x380	795x875x380	795x875x380	1340x900x320	1340x900x320		
Net weight		kg	37	55	55	55	88	88		
Refrigerant (R32) / CO <sub>2</sub> Eq.		kg / T	0,9/0,608	1,3/0,878	1,3/0,878	1,3/0,878	1,6/1,080	1,6/1,080		
Piping diameter	Liquid / Gas	Inch (mm)	1/4(6,35)/1/2(12,70)	1/4(6,35)/5/8(15,88)	1/4(6,35)/5/8(15,88)	1/4(6,35)/5/8(15,88)	1/4(6,35)/1/2(12,70)	1/4(6,35)/5/8(15,88)		
Pipe length range		m	3-25	3-40 [3-50] <sup>3)</sup>	3-40 [3-50] <sup>3)</sup>	3-40 [3-50] <sup>3)</sup>	3-30	3-30		
Elevation difference (in / out)		m	20	30	30	30	20	20		
Pre-charged pipe length		m	10	10	10	10	10	10		
Additional gas amount		g/m	20	25	25	25	30	30		
Operating range - outdoor ambient	Heat	°C	-20 ~ +35	-25 ~ +35	-25 ~ +35	-25 ~ +35	-25 ~ +35	-25 ~ +35		
	Cool	°C	+10 ~ +43	+10 ~ +43	+10 ~ +43	+10 ~ +43	+10 ~ +43	+10 ~ +43		
Water outlet <sup>4)</sup>	Heat / Cool	°C	20 ~ 60/5 ~ 20	20 ~ 60/5 ~ 20	20 ~ 60/5 ~ 20	20 ~ 60/5 ~ 20	20 ~ 60/5 ~ 20	20 ~ 60/5 ~ 20		
<b>Electrical information</b>		<b>Heater</b>	<b>3 kW</b>	<b>6 kW</b>	<b>3 kW</b>	<b>6 kW</b>	<b>3 kW</b>	<b>6 kW</b>	<b>6 kW</b>	<b>6 kW</b>
Electric backup heater		kW	3,00	6,00	3,00	6,00	3,00	6,00	6,00	6,00
Recommended fuse <sup>5)</sup>		A	16/16	16/30	16/16	16/30	25/16	25/30	30/30	30/30
Recommended minimum cable size, supply 1 / 2 <sup>5)</sup>		mm <sup>2</sup>	3x1,5/ 3x1,5	3x1,5/ 3x4,0	3x1,5/ 3x1,5	3x1,5/ 3x4,0	3x2,5/ 3x4,0	3x2,5/ 3x4,0	3x4,0/3x4,0	3x4,0/3x4,0

1) Scale from A+++ to D. 2) Sound power level in accordance to EN 12102 under conditions of the EN14825. 3) Operation range down to -25 °C in heating with 3-40 m pipe length range, operation range down to -15 °C in heating with 3-50 m pipe length range. 4) Between outdoor ambient -10 °C and -15 °C, the water outlet temperature gradually decreases from 60 °C to 55 °C. 5) Check local regulations. \*EER and COP calculation is based in accordance to EN 14511. \*\*This product is designed to comply with the European drinking water standard (EU) 2020/2184. The lifespan of the product is not guaranteed in the case of the use of groundwater, such as spring water or well water, the use of tap water when salt or other impurities are contained, nor in areas of acidic water quality. Maintenance and warranty costs related to these cases are the customer's responsibility.

Accessories	
<b>CZ-RTW1</b>	Optional remote controller for 2 zone control. K and L Series
<b>PAW-TD20C1E5-1</b>	Tank 200 L - Stainless steel
<b>PAW-TD30C1E5-1</b>	Tank 300 L - Stainless steel
<b>PAW-TA20C1E5STD</b>	Tank 200 L - Enamelled
<b>PAW-TA30C1E5STD</b>	Tank 300 L - Enamelled
<b>PAW-3WYVLV-HW</b>	3 way valve for DHW tanks
<b>CZ-NV2</b>	3 way valve kit to fit inside the hydrokit. K and L Series

Accessories	
<b>PAW-BTANK50L-2</b>	Buffer tank 50 L
<b>CZ-TAW1B</b>	Optional Wi-Fi or WLAN adapter for smart control via Comfort Cloud App and/or remote maintenance via Aquarea Service Cloud
<b>CZ-TAW1-CBL</b>	10 m extension cable for CZ-TAW1B
<b>CZ-NS5P</b>	PCB for advanced functions
<b>PAW-A2W-RTWIRED</b>	Room thermostat
<b>PAW-A2W-RTWIREDLESS</b>	Wireless LCD room thermostat



Check all our certified heat pumps on:  
[www.heatpumpkeymark.com](http://www.heatpumpkeymark.com)



Optional

## Aquarea High Performance Bi-bloc K Series. Three phase - SDC - R32

**Energy efficiency:** A+++ heating at 35 °C / "A"-rated variable-speed pump.

**Flexibility:** Built-in magnetic water filter.

**Comfort:** Operation without backup heater down to -25 °C / 60 °C flow temperature at -10 °C.

**Control:** Optimised user interface and improved features (2 zone control, bivalent control).

**Connectivity:** Optional Wi-Fi and BMS integration.

		Three phase (power to indoor)			
Kit 3 kW electric heater		KIT-WC09K3E8		—	
Kit 9 kW electric heater		KIT-WC09K9E8		KIT-WC12K9E8	
KIT-WC16K9E8					
Heating capacity / COP (A +7 °C, W 35 °C)	kW / COP	9,00/4,90	12,10/4,78	16,00/4,31	
Heating capacity / COP (A +7 °C, W 55 °C)	kW / COP	9,00/2,97	12,00/2,96	14,70/2,72	
Heating capacity / COP (A +2 °C, W 35 °C)	kW / COP	9,00/3,63	11,50/3,44	13,20/3,28	
Heating capacity / COP (A +2 °C, W 55 °C)	kW / COP	9,00/2,26	9,20/2,25	10,00/2,21	
Heating capacity / COP (A -7 °C, W 35 °C)	kW / COP	9,00/2,88	10,10/2,74	11,60/2,57	
Heating capacity / COP (A -7 °C, W 55 °C)	kW / COP	8,10/2,07	8,40/1,97	9,10/1,85	
Cooling capacity / EER (A 35 °C, W 7 °C)	kW / EER	8,80/3,11	10,70/2,68	13,40/2,64	
Cooling capacity / EER (A 35 °C, W 18 °C)	kW / EER	8,80/4,63	10,70/3,92	15,50/3,60	
Heating average climate (W 35 °C / W 55 °C)	Seasonal energy efficiency	SCOP (η <sub>s</sub> %)	4,96/3,57(195/140)	4,58/3,33(180/130)	4,46/3,40(176/133)
	Energy class <sup>1)</sup>		A+++ / A++	A+++ / A++	A+++ / A++
Heating warm climate (W 35 °C / W 55 °C)	Seasonal energy efficiency	SCOP (η <sub>s</sub> %)	6,47/4,34(256/171)	6,47/4,34(256/171)	6,20/4,30(245/169)
	Energy class <sup>1)</sup>		A+++ / A+++	A+++ / A+++	A+++ / A+++
Heating cold climate (W 35 °C / W 55 °C)	Seasonal energy efficiency	SCOP (η <sub>s</sub> %)	4,31/3,26(169/127)	4,31/3,26(169/127)	4,28/3,10(168/121)
	Energy class <sup>1)</sup>		A++ / A++	A++ / A++	A++ / A+
<b>Indoor unit 3 kW electric heater</b>		<b>WH-SDC09K3E8</b>		<b>—</b>	
<b>Indoor unit 9 kW electric heater</b>		<b>WH-SDC09K9E8</b>		<b>WH-SDC12K9E8</b>	
<b>WH-SDC16K9E8</b>					
Sound pressure	Heat / Cool	dB(A)	33/33	33/33	33/33
Dimension	H x W x D	mm	892 x 500 x 348	892 x 500 x 348	892 x 500 x 348
Net weight 3 kW / 9 kW		kg	40/41	—/41	—/41
Water pipe connector		Inch	R 1¼	R 1¼	R 1¼
A class pump	Number of speeds		Variable speed	Variable speed	Variable speed
	Input power	W	145	145	145
Heating water flow (ΔT=5 K, 35 °C)		L/min	25,8	34,4	45,9
<b>Outdoor unit</b>		<b>WH-UD209KE8</b>		<b>WH-UD212KE8</b>	
<b>WH-UD16KE8</b>					
Sound power <sup>2)</sup>	Heat	dB(A)	65	65	65
Dimension	H x W x D	mm	1340 x 900 x 320	1340 x 900 x 320	1340 x 900 x 320
Net weight		kg	90	90	103
Refrigerant (R32) / CO <sub>2</sub> Eq.		kg / T	1,60/1,080	1,60/1,080	1,83/1,235
Piping diameter	Liquid / Gas	Inch (mm)	1/4 (6,35)/1/2 (12,70)	1/4 (6,35)/1/2 (12,70)	1/4 (6,35)/1/2 (12,70)
Pipe length range		m	3~30	3~30	3~30
Elevation difference (in / out)		m	20	20	20
Pre-charged pipe length		m	10	10	10
Additional gas amount		g/m	30	30	30
Operating range - outdoor ambient	Heat	°C	-25 ~ +35	-25 ~ +35	-25 ~ +35
	Cool	°C	+10 ~ +43	+10 ~ +43	+10 ~ +43
Water outlet <sup>3)</sup>	Heat / Cool	°C	20~60/5~20	20~60/5~20	20~60/5~20
<b>Electrical information</b>		<b>3 kW heater</b>	<b>9 kW heater</b>	<b>9 kW heater</b>	<b>9 kW heater</b>
Electric backup heater	kW	3,00	9,00	9,00	9,00
Recommended fuse <sup>4)</sup>	A	20/15/16	20/20	20/20	20/20
Recommended minimum cable size, supply 1 / 2 <sup>4)</sup>	mm <sup>2</sup>	5x1,5/3x1,5	5x1,5/5x1,5	5x1,5/5x1,5	5x2,5/5x1,5

1) Scale from A+++ to D. 2) Sound power level in accordance to EN 12102 under conditions of the EN14825. 3) Operation range down to -25 °C in heating with 3~40 m pipe length range, operation range down to -15 °C in heating with 3~50 m pipe length range. 4) Check local regulations. \*EER and COP calculation is based in accordance to EN 14511. \*\*This product is designed to comply with the European drinking water standard (EU) 2020/2184. The lifespan of the product is not guaranteed in the case of the use of groundwater, such as spring water or well water, the use of tap water when salt or other impurities are contained, nor in areas of acidic water quality. Maintenance and warranty costs related to these cases are the customer's responsibility.

Accessories	
<b>CZ-RTW1</b>	Optional remote controller for 2 zone control. K and L Series
<b>PAW-TD20C1E5-1</b>	Tank 200 L - Stainless steel
<b>PAW-TD30C1E5-1</b>	Tank 300 L - Stainless steel
<b>PAW-TA20C1E5STD</b>	Tank 200 L - Enamelled
<b>PAW-TA30C1E5STD</b>	Tank 300 L - Enamelled
<b>PAW-3WYVLV-HW</b>	3 way valve for DHW tanks
<b>CZ-NV2</b>	3 way valve kit to fit inside the hydrokit. K and L Series

Accessories	
<b>PAW-BTANK50L-2</b>	Buffer tank 50 L
<b>CZ-TAW1B</b>	Optional Wi-Fi or WLAN adapter for smart control via Comfort Cloud App and/or remote maintenance via Aquarea Service Cloud
<b>CZ-TAW1-CBL</b>	10 m extension cable for CZ-TAW1B
<b>CZ-NS5P</b>	PCB for advanced functions
<b>PAW-A2W-RTWIRED</b>	Room thermostat
<b>PAW-A2W-RTWIRESLESS</b>	Wireless LCD room thermostat



## Aquarea EcoFlex. Single phase - R32

**Energy efficiency:** Heat recovery during cooling provides free DHW.

**Flexibility:** Small foot print outdoor unit / Up to 3 air to air indoor units plus an air to water unit with integrated DHW tank.

**Comfort:** Continuous heating down to -25 °C<sup>1)</sup> / nanoe™ X technology to improve protection 24/7.

**Connectivity:** Wi-Fi adapter included for smart control via Comfort Cloud App<sup>2)</sup>.

1) For CU-4WZ90CBE5, CU-2WZ71YBE5 operates down to -15 °C. 2) Except low static pressure hide-away indoor units.



NEW

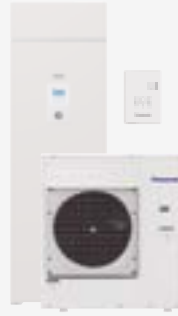

Included\*

Aquarea EcoFlex	Indoor units		Outdoor units	
	DHW tank	Electrical anode	CU-2WZ71YBE5	CU-4WZ90CBE5
<b>Air to water indoor units</b>			<b>1 unit</b>	<b>1 unit</b>
	185 L	—	✓	—
<b>Aquarea EcoFlex air to water indoor unit</b>	185 L	—	—	✓
	185 L	✓	—	✓
<b>Air to air indoor units</b>			<b>1 unit</b>	<b>Up to 3 units</b>
<b>Aquarea EcoFlex hide-away</b>	—	—	✓	✓
	—	—	—	✓
	—	—	—	✓
<b>Low static pressure hide-away</b>	—	—	—	✓
	—	—	—	✓
	—	—	—	✓
	—	—	—	✓
	—	—	—	✓
<b>Etherea wall-mounted (graphite grey / silver / matt white)</b>	—	—	—	✓
	—	—	—	✓
	—	—	—	✓
	—	—	—	✓
	—	—	—	✓
	—	—	—	✓
	—	—	—	✓

Outdoor unit			CU-2WZ71YBE5	CU-4WZ90CBE5	CU-4WZ90CBE5
<b>Connected air to air indoor units</b>			<b>1 (S-71WF3E)</b>	<b>1 (S-71WF3E)</b>	<b>2 - 3</b>
<b>Indoor nominal capacity (Min - Max)</b>			<b>— ~ 7,10 kW</b>	<b>— ~ 7,10 kW</b>	<b>3,20 ~ 11,00 kW</b>
Cooling capacity	Nominal (Min - Max)	kW	7,10 (1,20 - 8,10)	7,10 (1,60 - 9,00)	9,00 (1,60 - 10,20)
EER <sup>1)</sup>	Nominal (Min - Max)	W/W	3,40 (2,55 - 2,47)	3,40 (3,40 - 2,57)	3,83 (4,00 - 3,00)
<b>SEER<sup>2)</sup></b>			<b>5,60 A+</b>	<b>5,60 A+</b>	<b>7,00 A++</b>
Pdesign (cooling)		kW	7,10	7,10	9,00
Input power	Nominal (Min - Max)	kW	2,09 (0,47 - 3,28)	2,09 (0,47 - 3,50)	2,35 (0,40 - 3,40)
Annual energy consumption <sup>3)</sup>		kWh/a	444	444	450
Heating capacity	Nominal (Min - Max)	kW	7,10 (2,00 - 10,20)	7,10 (2,00 - 10,20)	9,50 (2,00 - 12,00)
Heating capacity at -7 °C		kW			
COP <sup>1)</sup>	Nominal (Min - Max)	W/W	3,90 (4,65 - 3,00)	3,90 (4,65 - 3,00)	4,30 (5,56 - 3,64)
<b>SCOP<sup>2)</sup></b>			<b>3,90 A</b>	<b>3,90 A</b>	<b>4,60 A++</b>
Pdesign at -10 °C		kW	4,80	5,80	6,50
Input power	Nominal (Min - Max)	kW	1,82 (0,43 - 3,40)	1,82 (0,43 - 3,40)	2,21 (0,36 - 3,30)
Annual energy consumption <sup>3)</sup>		kWh/a	1723	2082	1978
Current	Cool / Heat	A	10,1/8,7	10,1/8,7	11,2/10,6
Power supply		V	230	230	230
Recommended fuse		A			
Recommended power cable section		mm <sup>2</sup>			
Sound pressure <sup>4)</sup>	Cool / Heat (air to air)	dB(A)	49/49	49/49	53/55
Sound power <sup>4)</sup>	Cool / Heat (air to air)	dB(A)	68/67	68/67	69/70
Dimension / Net weight	H x W x D	mm / kg	999 x 940 x 340/82	999 x 940 x 340/83	999 x 940 x 340/83
Piping diameter	Liquid / Gas	Inch (mm)	1/4 (6,35) / 1/2 (12,70)	1/4 (6,35) / 3/8 (9,52)	1/4 (6,35) / 3/8 (9,52)
Maximum total piping length		m	70	70	80
Pipe length range to one unit		m	3 - 35	3 - 35	3 - 25
Elevation difference (in / out)		m	30	30	20
Pre-charged pipe length / Additional gas amount		m / g/m	30 / 20	30 / 25	30 / 25
Refrigerant (R32) / CO <sub>2</sub> Eq.		kg / T	2,40 / 1,62	2,58 / 1,74	2,58 / 1,74
Operating range - outdoor ambient	Heat (air to air)	°C	-15 ~ +24	-15 ~ +24	-25 ~ +24
	Cool (air to air)	°C	-10 ~ +46	-10 ~ +46	-10 ~ +46
	Heat (air to water)	°C	-15 ~ +35	-15 ~ +35	-25 ~ +35
	Heat recovery (floor / DHW)	°C	+10 ~ +35 / +10 ~ +46	+10 ~ +35 / +10 ~ +46	+10 ~ +35 / +10 ~ +46

1) EER and COP calculation is based in accordance to EN 14511. 2) SEER and SCOP data measurement is measured according to EN 14825. Scale from A+++ to D. 3) The annual energy consumption is calculated in accordance to EU/626/2011. 4) The sound pressure and power is measured under cooling mode (outdoor 35 °C DB, indoor 27 °C/19 °C) and heating mode (outdoor 7 °C/6 °C, indoor 20 °C DB). Sound pressure is measured with distance 1,0 m from the unit and height at 1,5 m.



HEATING MODE: For CU-4WZ90CBE5. WI-FI INCLUDED: For EcoFlex hide-away and Etherea wall-mounted units.

Indoor unit		WH-ADF0309J3E5CM		WH-ADF0309K3E5M		WH-ADF0309K3E5ANM	
Compatible outdoor unit		CU-2WZ71YBE5		CU-4WZ90CBE5		CU-4WZ90CBE5	
Heating capacity / COP <sup>1)</sup> [A +7 °C, W 35 °C]	kW / COP	8,00/4,21		8,00/4,21		8,00/4,21	
Heating capacity / COP <sup>1)</sup> [A +7 °C, W 55 °C]	kW / COP	8,00/2,81		8,00/2,81		8,00/2,81	
Heating capacity / COP <sup>1)</sup> [A +2 °C, W 35 °C]	kW / COP	6,70/3,25		6,70/3,25		6,70/3,25	
Heating capacity / COP <sup>1)</sup> [A +2 °C, W 55 °C]	kW / COP	6,00/2,08		6,00/2,08		6,00/2,08	
Heating capacity / COP <sup>1)</sup> [A -7 °C, W 35 °C]	kW / COP	5,60/2,84		5,60/2,84		5,60/2,84	
Heating capacity / COP <sup>1)</sup> [A -7 °C, W 55 °C]	kW / COP	5,30/1,91		5,30/1,91		5,30/1,91	
Heating average climate (W 35 °C / W 55 °C)	Seasonal energy efficiency <sup>2)</sup>	SCOP (η <sub>s</sub> %) 4,00/3,20(157/125)		4,00/3,20(157/125)		4,00/3,20(157/125)	
	Energy class <sup>3)</sup>	A+++ to D		A++/A++		A++/A++	
Heating warm climate (W 35 °C / W 55 °C)	Seasonal energy efficiency <sup>2)</sup>	SCOP (η <sub>s</sub> %) 5,69/3,69(224/145)		5,69/3,69(224/145)		5,69/3,69(224/145)	
	Energy class <sup>3)</sup>	A+++ to D		A+++/A++		A+++/A++	
Heating cold climate (W 35 °C / W 55 °C)	Seasonal energy efficiency <sup>2)</sup>	SCOP (η <sub>s</sub> %) 3,61/2,80(141/109)		3,61/2,80(141/109)		3,61/2,80(141/109)	
	Energy class <sup>3)</sup>	A+++ to D		A+/A+		A+/A+	
Sound pressure <sup>4)</sup>	Heat	dB(A) 28		28		28	
Dimension / Net weight	H x W x D	mm / kg 1880 x 598 x 600 / 108		1882 x 599 x 602 / 107		1882 x 599 x 602 / 107	
Electric backup heater		kW 3,00		3,00		3,00	
Water volume		L 185		185		185	
Maximum DHW temperature		°C 65		65		65	
Heating water flow (ΔT=5 K, 35 °C)		L/min 22,90		22,90		22,90	
Tapping profile according EN16147		L		L		L	
DHW tank ERP efficiency average / warm / cold <sup>5) 6)</sup>		A+ to F		A/A+/A		A/A+/A	
DHW tank ERP average climate η / COP <sub>DHW</sub> <sup>5)</sup>	η <sub>wh</sub> % / COP <sub>DHW</sub>	104/2,60		104/2,60		104/2,60	
DHW tank ERP warm climate η / COP <sub>DHW</sub> <sup>5)</sup>	η <sub>wh</sub> % / COP <sub>DHW</sub>	134/3,35		134/3,35		134/3,35	
DHW tank ERP cold climate η / COP <sub>DHW</sub> <sup>5)</sup>	η <sub>wh</sub> % / COP <sub>DHW</sub>	92/2,30		92/2,30		92/2,30	
Heat recovery capacity (DHW 55 °C)	kW	7,10+9,00		7,10+9,00		7,10+9,00	
Heat recovery input power (DHW 55 °C)	kW	3,15		3,15		3,15	
Heat recovery COP (DHW 55 °C)		5,11		5,11		5,11	
Water outlet		°C 20 - 55		20 - 55		20 - 55	
Piping diameter	Liquid / Gas	Inch (mm) 1/4 (6,35) / 1/2 (12,70)		3/8 (9,52) / 5/8 (15,88)		3/8 (9,52) / 5/8 (15,88)	
Water pipe diameter	Room / DHW	Inch (mm) 1 1/4 / 3/4		1 1/4 / 3/4		1 1/4 / 3/4	





1) EER and COP calculation is based in accordance to EN 14511. 2) SEER & SCOP data measurement is measured at condition according to EN 14825. 3) Scale from A+++ to D. 4) The sound pressure and power is measured under cooling mode (outdoor 35 °C DB, indoor 27 °C/19 °C) and heating mode (outdoor 7 °C/6 °C, indoor 20 °C DB). Sound pressure is measured with distance 1,0 m from the unit and height at 1,5 m. 5) Tank DHW tapping COP is measured under condition according to EN 16147. 6) Scale from A+ to F.



**CONEX wired remote controller, white.**  
CZ-RTC6W/BL/BLW2





**CONEX wired remote controller, black.**  
CZ-RTC6/BL/BLW2

Aquarea EcoFlex hide-away	Indoor unit	Cooling capacity	Heating capacity	External static pressure <sup>1)</sup>	Sound pressure <sup>2)</sup>	Dimension / Net weight	Piping diameter
		kW	kW		Pa		Cool — Heat (Hi/Lo/Q-Lo)
7,1 kW	S-71WF3E	7,10	7,10	10 - 150	34/26/- — 34/26/-	250 x 1000 x 730/30	1/4 (6,35) / 1/2 (12,70)







**Optional wireless control kit.**  
CZ-RL511D

NEW! Low static pressure hide-away	Indoor unit	Cooling capacity	Heating capacity	External static pressure <sup>1)</sup>	Sound pressure <sup>2)</sup>	Dimension / Net weight	Piping diameter
		kW	kW		Pa		Cool — Heat (Hi/Lo/Q-Lo)
2,0 kW	CS-MZ20CD3EA	2,00	2,80	15 - 45	34/29/26 — 36/29/26	200 x 750 x 640 / 19	1/4 (6,35) / 3/8 (9,52)
2,5 kW	CS-Z25CD3EAW	2,50	3,20	15 - 45	35/29/26 — 37/29/26	200 x 750 x 640 / 19	1/4 (6,35) / 3/8 (9,52)
3,5 kW	CS-Z35CD3EAW	3,50	4,00	15 - 45	35/29/26 — 37/29/26	200 x 750 x 640 / 19	1/4 (6,35) / 3/8 (9,52)
5,0 kW	CS-Z50CD3EAW	5,00	6,00	15 - 50	41/31/28 — 41/32/29	200 x 750 x 640 / 19	1/4 (6,35) / 3/8 (9,52)
6,0 kW	CS-Z60CD3EAW	6,00	7,50	15 - 50	41/32/29 — 43/34/31	200 x 750 x 640 / 19	1/4 (6,35) / 1/2 (12,70)



**Optional wired remote controller.**  
CZ-RD517C

NEW! Wall-mounted Etherea	Indoor unit graphite grey	Indoor unit silver	Indoor unit matt white	Cooling capacity	Heating capacity	Sound pressure <sup>3)</sup>	Dimension / Net weight	Piping diameter
				kW	kW			Cool — Heat (Hi/Lo/Q-Lo)
1,6 kW	—	—	CS-MZ16CKE	1,60	2,30	37/26/21 — 38/27/21	295 x 870 x 229 / 10	1/4 (6,35) / 3/8 (9,52)
2,0 kW	CS-XZ20CKEW-H	CS-XZ20CKEW	CS-Z20CKEW	2,00	2,80	37/26/21 — 38/27/21	295 x 870 x 229 / 10	1/4 (6,35) / 3/8 (9,52)
2,5 kW	CS-XZ25CKEW-H	CS-XZ25CKEW	CS-Z25CKEW	2,50	3,20	41/27/21 — 41/29/21	295 x 870 x 229 / 10	1/4 (6,35) / 3/8 (9,52)
3,5 kW	CS-XZ35CKEW-H	CS-XZ35CKEW	CS-Z35CKEW	3,50	4,00	44/30/21 — 45/35/21	295 x 870 x 229 / 11	1/4 (6,35) / 3/8 (9,52)
4,2 kW	CS-XZ42CKEW-H	—	CS-Z42CKEW	4,20	4,90	44/33/27 — 45/37/31	295 x 870 x 229 / 10	1/4 (6,35) / 3/8 (9,52)
5,0 kW	—	CS-XZ50CKEW	CS-Z50CKEW	5,00	6,00	44/39/32 — 46/39/32	295 x 1040 x 244 / 12	1/4 (6,35) / 3/8 (9,52)
7,1 kW	—	—	CS-Z71CKEW	7,10	7,70	49/40/32 — 49/40/32	295 x 1040 x 244 / 13	1/4 (6,35) / 1/2 (12,70)

1) The specification listed on the table indicates values under the condition of 25 Pa (2,5 mmAq) which are applied for factory default setting. Change switch on PCB from Hi to S-Hi to have more than 6,0 mmAq. 2) The sound pressure of the indoor unit shows the value measured at a position of 1,5 m below the unit with 1 m duct on the suction side and 2 m duct on the discharge side. The sound pressure is measured in accordance with JIS C 9612. 3) The sound pressure of the indoor unit shows the value measured at a position of 1 m in front of the main body and 0,8 m below the unit. The sound pressure is measured in accordance with JIS C 9612. Q-Lo: Quiet mode. Lo: The lowest set fan speed.

### Possible outdoor / indoor units combinations

Rooms	Outdoor unit	Indoor capacity connected (Min - Max)	Aquarea EcoFlex hide-away						Low static pressure hide-away					Wall-mounted Etherea				
			71	20	25	35	50	60	16	20	25	35	42	50	71			
1	CU-2WZ71YBE5	— ~ 7,10 kW	✓															
1	CU-4WZ90CBE5	— ~ 7,10 kW	✓ <sup>1)</sup>															
2 - 3	CU-4WZ90CBE5	3,20 ~ 11,00 kW	✓ <sup>1)</sup>	✓	✓	✓	✓ <sup>2)</sup>	✓	✓	✓	✓	✓ <sup>2)</sup>	✓ <sup>2)</sup>	✓ <sup>3)</sup>	✓ <sup>3)</sup>	✓ <sup>3)</sup>	✓ <sup>3)</sup>	✓ <sup>3)</sup>

1) Pipe reducer CZ-MA2PA required. 2) Pipe reducer CZ-MA1PA required. 3) Pipe reducer CZ-MA2PA and CZ-MA3PA required.

# Aquarea Loop: Efficient radiator retrofit for centralised heating with integrated cooling

The Aquarea Loop is a decentralised water-to-air heat pump using natural refrigerant R290, designed to replace radiators in centralised heating systems.



Ideal for multi-family buildings, social housing, hotels, schools, offices, ...

Choice of pre-installed hydraulic options available.

2 and 3 way valves with modulation.

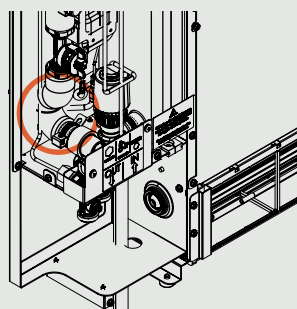

Injection kit.

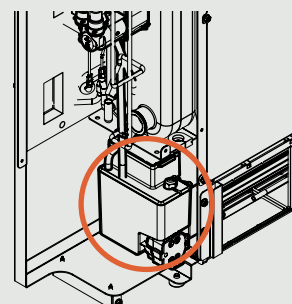

If it is not possible to pipe away condensation, it is possible to reinject it into the system thanks to an optional kit which can be installed inside of the unit.



### Aquarea Loop - R290

- Compact indoor unit – only 140 mm depth
- DC Inverter compressor with natural refrigerant R290
- Simultaneous heating and cooling capability
- Low temperature water loop (20 - 30 °C) all year round
- Use of existing piping for renovations\*
- Integrated unit-level energy metering

\*Based on the low flow rate requirement – must be checked on each project.

Model (the complete model codes are shown in the table below)			P-CWSL10	P-CWSL20	P-CWSL30
Cooling capacity <sup>1)</sup>	Nominal (Min - Max)	kW	1,10(0,20 - 1,20)	1,50(0,30 - 1,70)	2,60(0,60 - 3,00)
EER		W/W	4,40	4,80	4,80
<b>SEER <sup>2)</sup></b>			<b>5,50</b>	<b>6,10</b>	<b>7,90</b>
Input power <sup>1)</sup>		kW	0,2	0,3	0,5
Heating capacity <sup>3)</sup>	Nominal (Min - Max)	kW	1,10(0,40 - 1,40)	2,00(0,40 - 2,30)	3,10(0,80 - 3,60)
COP		W/W	5,20	5,40	5,90
<b>SCOP <sup>2)</sup></b>			<b>6,44</b>	<b>6,92</b>	<b>6,74</b>
Input power <sup>3)</sup>		kW	0,2	0,4	0,5
<b>Ventilation</b>					
Ventilation speeds			4	4	4
Air flow	Min / Ave / Max	m <sup>3</sup> /h	50/105/160	100/205/330	175/305/500
<b>Electrical data</b>					
Power supply	Voltage	V	230	230	230
	Phase		Single phase	Single phase	Single phase
	Frequency	Hz	50	50	50
Maximum input current		mA	1,74	3,87	5,01
Maximum consumption		kW	0,40	0,89	1,15
<b>Sound levels</b>					
Sound power <sup>4)</sup>	Max	dB(A)	48	50	52
Sound pressure <sup>5)</sup>	Min / Nom / Max	dB(A)	28/33/40	29/34/42	31/35/44
<b>Hydraulic data</b>					
Connection type			Eurokonus	Eurokonus	Eurokonus
Hydraulic connections		Inch	¾	¾	¾
Water flow rate	Heating / Cooling	L/min	3,7/4,5	7,7/5,2	12,0/9,0
Nominal pressure drop	Heating / Cooling	kPa	6,80/4,80	11,20/5,40	12,50/7,50
Nominal pressure drop with flow control valve	Heating / Cooling	kPa	7,80/5,40	14,20/6,70	20,50/11,80
Refrigerant (R290)		kg	0,10	0,14	0,15
<b>Dimension and weight</b>					
Dimension / Net weight	H x W x D	mm / kg	641 x 775 x 144 / 135	641 x 975 x 144 / 140	641 x 1225 x 144 / 145
<b>Operating range and water outlet</b>					
Operating range - indoor air	Heating / Cooling	°C	5 - 27 / 18 - 35	5 - 27 / 18 - 35	5 - 27 / 18 - 35
Water outlet	Heating / Cooling	°C	10 - 45 / 15 - 50	10 - 45 / 15 - 50	10 - 45 / 15 - 50

1) Loop water temperature 30 °C - Ambient air temperature 27 °C, indoor humidity 38% - Performance according to EN 14511. 2) SEER and SCOP in accordance with EN 14825. 3) Ring water temperature 20 °C - Ambient air temperature 20 °C, indoor humidity 50% - Performance according to EN 14511. 4) Sound power measured according to EN 16583. 5) Sound pressure at a distance of 1 m measured according to ISO 7779.

Aquarea Loop with on-board display					
Hydraulic configuration	Without valves		P-CWSL10SC5-HCE	P-CWSL20SC5-HCE	P-CWSL30SC5-HCE
	Without valves + injection kit		P-CWSL10SC5-HFE	P-CWSL20SC5-HFE	P-CWSL30SC5-HFE
	2 and 3 way valve with modulation		P-CWSL10SC5-HBE	P-CWSL20SC5-HBE	P-CWSL30SC5-HBE
	2 and 3 way valve with modulation + injection kit		P-CWSL10SC5-HEE	P-CWSL20SC5-HEE	P-CWSL30SC5-HEE
Aquarea Loop with on-board display with integrated Wi-Fi					
Hydraulic configuration	Without valves		P-CWSL10SC5-WCE	P-CWSL20SC5-WCE	P-CWSL30SC5-WCE
	Without valves + injection kit		P-CWSL10SC5-WFE	P-CWSL20SC5-WFE	P-CWSL30SC5-WFE
	2 and 3 way valve with modulation		P-CWSL10SC5-WBE	P-CWSL20SC5-WBE	P-CWSL30SC5-WBE
	2 and 3 way valve with modulation + injection kit		P-CWSL10SC5-WEE	P-CWSL20SC5-WEE	P-CWSL30SC5-WEE

## Aquarea Home App

### Download free app.

Other hardware requirements: Router and Internet (purchase and subscribe separately). Panasonic Cloud Server is designed, operated and managed by Panasonic.

\*The app screen is for illustration purposes only. The actual screen may differ.



Aquarea Home



# Aquarea Air Smart fan coils

Stylish, compact fan coil units for high comfort and energy savings.

MORE FAN COIL OPTIONS IN  
FAN COIL UNITS SECTION



## AC SELECT.





Smart and user-friendly selection tool.

Configure your air conditioning solution at required conditions: <https://acselect.panasonic.eu/>



**Aquarea Air Smart fan coils have a minimal visual impact and can be elegantly integrated into any home or office environment, adapting to any type of furniture.**

Designed to provide both heating and cooling in one compact unit, they maximise energy savings when combined with an Aquarea Heat Pumps.

 <p><b>SLIM, SOPHISTICATED DESIGN WITH METAL CASING</b></p>	 <p><b>SELF-MODULATING AIRFLOW (PI LOGIC) AND DC INVERTER FAN MOTOR</b></p>
 <p><b>WIDE RANGE WITH MULTIPLE CONFIGURATION OPTIONS</b></p>	 <p><b>ADVANCED CONTROL AND CONNECTIVITY OPTIONS</b></p>

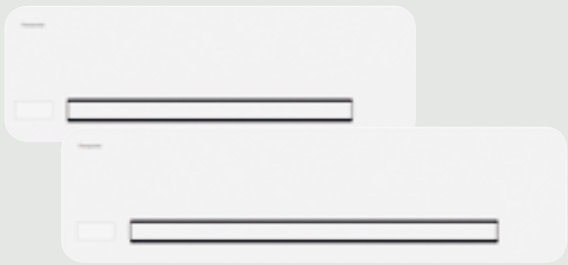
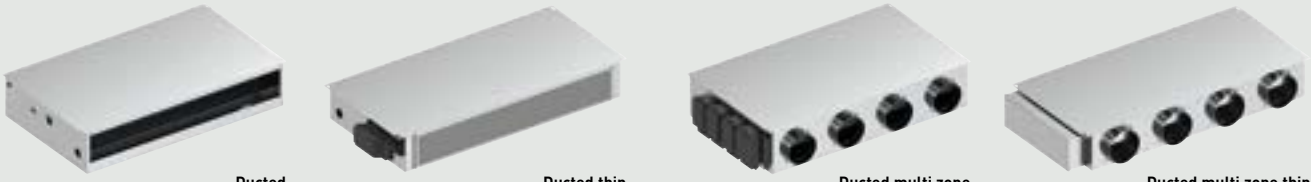
<p><b>Aquarea Air Smart fan coil – Floor standing.</b> Even narrower and thinner fan coils.</p> 	<p><b>Aquarea Air Smart fan coil – Wall-mounted.</b> The thinnest and most quietest in its class.</p> 
<p><b>Aquarea Air Smart fan coil – Ducted / ducted multi zone.</b> Thin version with only 185 mm height. Integrated multi zone management (2-5 zones, with the multi zone line-up).</p>  <p style="display: flex; justify-content: space-around;"> <span>Ducted</span> <span>Ducted thin</span> <span>Ducted multi zone</span> <span>Ducted multi zone thin</span> </p>	



Self-modulated air flow control by the unit.

**The fan speed is no longer "stepped" but continuously modulated with proportional and integrative logic: this reduces both noise and annoying air movements.**

**Aquarea Home App**

**Download free app.**

Other hardware requirements: Router and Internet (purchase and subscribe separately). Panasonic Cloud Server is designed, operated and managed by Panasonic.

\*The app screen is for illustration purposes only. The actual screen may differ.

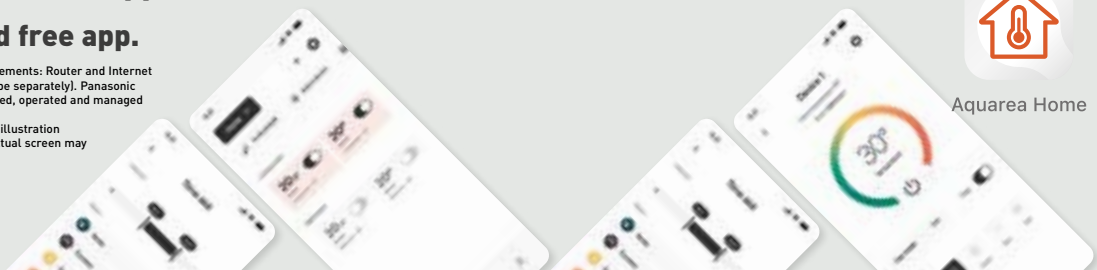

## Aquarea Air Smart fan coil – Floor standing

Slim chassis profile, only 129 mm / RAL 9003 / DC Inverter – maximising comfort and energy savings / Modulated air flow.

**Possible configurations:** Left or right water connections / 2 or 3 way valves as accessories / On-board or wall mounted control or PCB for analog input (0-10 V)



Optional 

Model [the complete model codes are shown in the table below]		P-FAL10	P-FAL20	P-FAL30	P-FAL35	P-FAL40
<b>Fan speed <sup>1)</sup></b>		<b>Min / Med / Max</b>	<b>Min / Med / Max</b>	<b>Min / Med / Max</b>	<b>Min / Med / Max</b>	<b>Min / Med / Max</b>
Total cooling capacity <sup>2)</sup>	kW	0,43/0,73/0,91	0,75/1,36/2,12	1,15/2,08/2,81	1,32/2,39/3,30	1,36/2,57/3,71
Sensible capacity <sup>2)</sup>	kW	0,29/0,51/0,71	0,59/1,04/1,54	0,83/1,51/2,11	1,02/1,84/2,65	1,05/1,98/2,90
Water flow <sup>2)</sup>	l/h	73,67/125,07/155,91	128,50/233,01/363,22	197,03/356,36/481,43	226,15/409,48/565,39	—
Water pressure drop <sup>2)3)</sup>	kPa	5,7/10,2/12,1	1,9/4,3/8,2	2,7/9,9/17,1	2,5/8,8/18,0	—
Heating capacity <sup>4)</sup>	kW	0,37/0,69/1,00	0,82/1,50/2,19	1,19/2,15/2,99	1,45/2,56/3,73	1,47/2,78/4,23
Water flow <sup>4)</sup>	l/h	65,11/120,91/179,87	144,60/269,80/389,71	211,61/380,89/532,55	259,22/456,72/671,86	—
Water pressure drop <sup>3)4)</sup>	kPa	2,6/6,8/9,1	1,5/4,3/9,2	2,7/9,3/19,1	3,0/8,9/21,2	—
<b>Sound levels</b>						
Sound power	dB(A)	37/47/54	37/47/54	37/47/57	37/47/55	37/48/58
Sound pressure <sup>5)</sup>	dB(A)	24/33/41	25/34/42	26/34/44	26/35/46	28/38/47
<b>Ventilation</b>						
Number of fans		1	1	1	1	1
Air flow	m <sup>3</sup> /h	49/91/146	124/210/294	194/318/438	302/410/567	364/479/663
Maximum static pressure	Pa	10	10	13	13	13
<b>Electrical data</b>						
Power supply	V / Phase / Hz	V	230/1/50	230/1/50	230/1/50	230/1/50
Consumption	W	7,0/9,0/13,0	14,0/18,0/22,0	16,0/20,0/24,0	18,0/22,0/26,5	—
<b>Water connections</b>						
Hydraulic connections type		Eurokonus	Eurokonus	Eurokonus	Eurokonus	Eurokonus
Hydraulic connections	Inch	¾	¾	¾	¾	¾
<b>Dimension and weight</b>						
Dimension / Weight	HxWxD	mm / kg	579 x 680 x 129/17	579 x 880 x 129/20	579 x 1080 x 129/23	579 x 1280 x 129/26

1) Fan standard factory set speeds. 2) According to Eurovent standard. Air: 27 °C DB/19 °C WB, chilled water: 7 °C/12 °C. 3) Pressure loss by corresponding nominal flow. 4) According to Eurovent standard. Air: 20 °C, hot water: 45 °C/40 °C. 5) Informative data, considering an hypothetical sound attenuation of the room and installation of 9 dB(A).

### Option 1. Standard configurations with built-in accessories

#### Fan coil with on-board display

Left-hand piping, vertical installation, built-in 3 way valve

P-FAL10SC-HLE

P-FAL20SC-HLE

P-FAL30SC-HLE

P-FAL35SC-HLE

P-FAL40SC-HLE

#### Fan coil with wall-mounted control

Left-hand piping, vertical installation, built-in 3 way valve

P-FAL10SC-RLE

P-FAL20SC-RLE

P-FAL30SC-RLE

P-FAL35SC-RLE

P-FAL40SC-RLE

Control (required, to be ordered separately)	With Modbus	<b>PCZ-EEB749</b>
	With integrated Wi-Fi	<b>PCZ-EFB749</b>

### Option 2. Configure your own Aquarea Air Smart fan coil – Floor standing unit

Left-hand piping	Right-hand piping
------------------	-------------------

P-FAL10SC-00E

P-FAL10DC-00E

P-FAL20SC-00E

P-FAL20DC-00E

P-FAL30SC-00E

P-FAL30DC-00E

P-FAL35SC-00E

P-FAL35DC-00E

P-FAL40SC-00E

P-FAL40DC-00E

<b>Control options (required)</b>	On-board display	With Modbus	<b>PCZ-ECA844</b>
		With integrated Wi-Fi	<b>PCZ-EWA844</b>
	Wall-mounted control	With Modbus	<b>PCZ-ESE845 + PCZ-EEB749</b>
		With integrated Wi-Fi	<b>PCZ-ESE845 + PCZ-EFB749</b>
	PCB for analog control (0-10 V)		<b>PCZ-B10842</b>

<b>Valve kits (optional)</b>	3 way valve with motor	<b>PCZ-V30720</b>
	2 way valve with motor	<b>PCZ-V20139</b>

<b>Condensate drip tray for horizontal installation (optional)</b>	For P-FAL10	<b>PCZ-GB0520</b>
	For P-FAL20	<b>PCZ-GB0521</b>
	For P-FAL30	<b>PCZ-GB0522</b>
	For P-FAL35	<b>PCZ-GB0523</b>
	For P-FAL40	<b>PCZ-GB0524</b>

#### Accessories and options

**PCZ-LC0158** Set of 2 legs to protect water pipes

#### Accessories and options

**PCZ-LC0606** Set of 2 legs to anchor the unit to the floor

### Control options.

**On-board display with Modbus or integrated Wi-Fi.**



**Wall-mounted control with Modbus or integrated Wi-Fi.**

PCZ-EEB749 /  
PCZ-EFB749

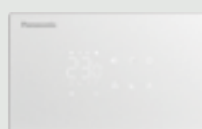

**PCB for analog control (0-10 V).**

PCZ-B10842

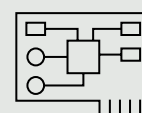

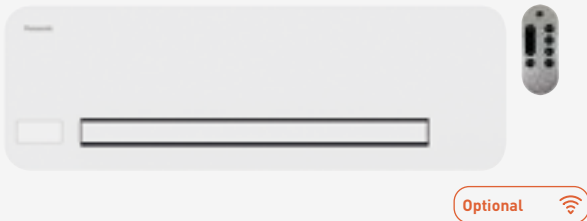

### Aquarea Air Smart fan coil – Wall-mounted

Slim chassis profile, only 128 mm / RAL 9003 / DC Inverter – maximising comfort and energy savings / Modulated air flow.  
**Possible configurations:** Left or right water connections / 2 or 3 way valves as accessories / On-board or wall mounted control or PCB for analog input (0-10 V)

Optional

Model (the complete model codes are shown in the table below)		P-FMM10	P-FMM15	P-FMM20	P-FMM40
<b>Fan speed <sup>1)</sup></b>		<b>Min / Med / Max</b>	<b>Min / Med / Max</b>	<b>Min / Med / Max</b>	<b>Min / Med / Max</b>
Total cooling capacity <sup>2)</sup>	kW	0,49/0,88/1,24	0,62/1,08/1,61	0,70/1,21/1,94	1,32/2,66/3,94
Sensible capacity <sup>2)</sup>	kW	0,37/0,70/0,98	0,52/0,86/1,27	0,57/1,02/1,52	1,08/2,05/2,92
Water flow <sup>2)</sup>	l/h	84,00/150,80/212,40	106,20/185,00/275,80	119,90/207,30/332,40	226,40/455,30/674,30
Water pressure drop <sup>2)</sup>	kPa	4,8/10,5/11,7	4,7/5,6/5,1	5,5/5,4/5,3	1,8/6,0/12,1
Heating capacity <sup>3)</sup>	kW	0,54/0,98/1,45	0,76/1,30/1,93	0,78/1,49/2,28	1,63/3,04/4,44
Water flow <sup>3)</sup>	l/h	97,00/176,30/264,50	139,30/239,80/354,40	141,10/273,30/414,40	296,40/547,00/800,90
Water pressure drop <sup>3)</sup>	kPa	5,1/12,0/16,3	4,8/6,3/7,2	6,0/6,4/8,1	2,3/6,9/14,1
<b>Sound levels</b>					
Sound power	dB(A)	35/46/53	36/47/54	37/48/58	38/48/62
Sound pressure <sup>4)</sup>	dB(A)	25/33/40	25/34/41	26/34/42	27/37/51
<b>Ventilation</b>					
Air flow	m <sup>3</sup> /h	84/155/228	124/229/331	138/283/440	230/480/788
<b>Electrical data</b>					
Power supply	V / Phase / Hz	V	230/1/50	230/1/50	230/1/50
Consumption	W	5/8/19	5/9/20	5/11/29	8/23/30
<b>Water connections</b>					
Hydraulic connections type		Eurokonus	Eurokonus	Eurokonus	Eurokonus
Hydraulic connections	Inch	¾	¾	¾	¾
<b>Dimension and weight</b>					
Dimension / Weight	H x W x D	mm / kg	335 x 815 x 128 / 14	335 x 1015 x 128 / 16	335 x 1215 x 128 / 19
			335 x 1215 x 215 / 24		

1) Fan standard factory set speeds. 2) According to Eurovent standard. Air: 27 °C DB/19 °C WB, chilled water: 7 °C/12 °C. 3) According to Eurovent standard. Air: 20 °C, hot water: 45 °C/40 °C. 4) Informative data, considering an hypothetical sound attenuation of the room and installation of 9 dB(A).

#### Option 1. Standard configurations with built-in accessories

Fan coil with on-board display and wireless IR control		
Right-hand piping, built-in 3 way valve		
P-FMM10DC-QNE		
P-FMM15DC-QNE		
P-FMM20DC-QNE		
P-FMM40DC-QNE		

Fan coil with wall-mounted control		
Right-hand piping, built-in 3 way valve		
P-FMM10DC-RNE		
P-FMM15DC-RNE		
P-FMM20DC-RNE		
P-FMM40DC-RNE		
Control (required, to be ordered separately)	With Modbus	PCZ-EEB749
	With integrated Wi-Fi	PCZ-EFB749

#### Option 2. Configure your own Aquarea Air Smart fan coil – Wall-mounted unit

Fan coil with on-board display and wireless IR control		
Left-hand piping		Right-hand piping
P-FMM10SC-Q0E		P-FMM10DC-Q0E
P-FMM15SC-Q0E		P-FMM15DC-Q0E
P-FMM20SC-Q0E		P-FMM20DC-Q0E
—		P-FMM40DC-Q0E

Fan coil with wall-mounted control		
Left-hand piping		Right-hand piping
P-FMM10SC-R0E		P-FMM10DC-R0E
P-FMM15SC-R0E		P-FMM15DC-R0E
P-FMM20SC-R0E		P-FMM20DC-R0E
—		P-FMM40DC-R0E
Control (required, to be ordered separately)	With Modbus	PCZ-EEB749
	With integrated Wi-Fi	PCZ-EFB749

Fan coil with PCB for analog control (0-10 V)		
Left-hand piping		Right-hand piping
P-FMM10SC-V0E		P-FMM10DC-V0E
P-FMM15SC-V0E		P-FMM15DC-V0E
P-FMM20SC-V0E		P-FMM20DC-V0E
—		P-FMM40DC-V0E

Valve kits (optional)		
PCZ-V30688	3 way valve with motor for models 10, 15, 20	
PCZ-V30718	3 way valve with motor for model 40	

Valve kits (optional)		
PCZ-V20687	2 way valve with motor for models 10, 15, 20	
PCZ-V20139	2 way valve with motor for model 40	

#### Control options.

On-board display with Modbus.



Wall-mounted control with Modbus or integrated Wi-Fi.

PCZ-EEB749 / PCZ-EFB749

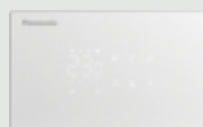

PCB for analog control (0-10 V).

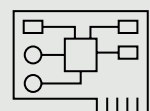

### Aquarea Air Smart fan coil – Ducted thin / ducted

Fan coil ducted units with cooling and heating.

Cooling capacity: 0,7 to 5,3 kW.

Heating capacity: 0,7 to 5,8 kW.

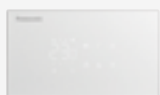

Optional controller.  
Wall-mounted control  
with Modbus.  
PCZ-EEB749

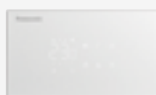

Optional controller.  
Wall-mounted control  
with integrated Wi-Fi.  
PCZ-EFB749



Optional controller.  
PCB for analog control  
(0-10 V).

CHECK PAGE 112 FOR A WIDER SELECTION OF ACCESSORIES

### The range at a glance

- Slim profile, only 185 mm for the thin version
- DC Inverter – maximising comfort and energy savings
- Modulated air flow
- Quiet operation
- Centrifugal fan with single motor impeller
- Vertical or horizontal installation

### Possible configurations

- Left or right water connections
- 2 or 3 way valves as accessories
- Wall-mounted control or PCB for analog input (0-10 V)

High-efficiency ducted fan coil for high comfort and quiet operation thanks to self modulating air flow control.

### Ducted thin, designed to fit any space

With a height of only 185 mm, the thin version is even more versatile than the classic version and fits perfectly into any wall or false ceiling with either horizontal or vertical installation.



### High installation flexibility.

#### Horizontal installation.

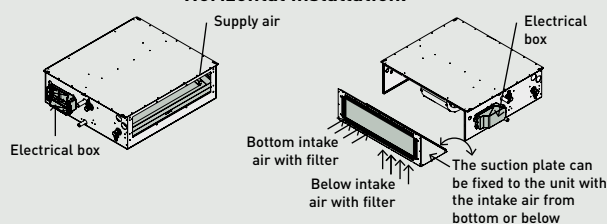

#### Vertical installation.

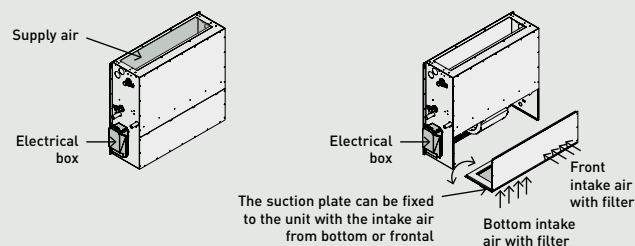

Technical performance

		Ducted thin					Ducted				
Model <small>(the complete model codes are shown in the table below)</small>		P-FTN15	P-FTN20	P-FTN25	P-FTN35	P-FTN45	P-FSN20	P-FSN25	P-FSN35	P-FSN45	P-FSN55
Fan speed <sup>1)</sup>		Min / Med / Max	Min / Med / Max	Min / Med / Max	Min / Med / Max	Min / Med / Max	Min / Med / Max	Min / Med / Max	Min / Med / Max	Min / Med / Max	Min / Med / Max
Total cooling capacity <sup>2)</sup>	kW	0,66/1,14 /1,40	1,01/1,84 /2,10	1,23/2,17 /2,60	1,47/2,40 /3,30	1,72/2,80 /4,45	0,82/1,37 /1,88	1,27/1,86 /2,14	1,53/2,38 /2,97	1,81/3,22 /3,48	1,82/3,97 /5,31
Sensible capacity <sup>2)</sup>	kW	0,46/0,84 /1,05	0,70/1,27 /1,50	0,88/1,56 /2,10	1,06/1,77 /2,45	1,23/2,33 /3,20	0,61/0,96 /1,48	0,93/1,43 /1,56	1,17/1,98 /2,92	1,33/2,58 /2,95	1,33/2,75 /3,65
Water flow <sup>2)</sup>	l/h	113/195 /270	173/315 /405	211/373 /510	251/412 /610	295/481 /805	141/235 /322	218/319 /367	262/408 /509	310/552 /596	312/680 /910
Water pressure drop <sup>2)3)</sup>	kPa	1,0/3,0 /5,0	2,0/5,0 /8,0	4,0/10,0 /17,0	2,0/5,0 /11,0	2,0/6,0 /14,0	9,2/11,8 /15,7	9,9/14,9 /19,4	2,4/2,8 /2,9	9,0/12,6 /14,6	4,1/16,1 /27,2
Heating capacity <sup>4)</sup>	kW	0,68/1,32 /1,65	1,01/1,80 /2,10	1,32/2,32 /2,86	1,63/2,76 /3,71	1,89/3,98 /5,20	0,9/1,48 /1,98	1,36/2,04 /2,54	1,81/2,63 /3,45	1,96/3,77 /4,46	1,95/4,23 /5,73
Water flow <sup>4)</sup>	l/h	115/222 /310	170/303 /440	235/410 /540	288/486 /730	329/692 /880	159/261 /349	239/360 /448	319/464 /608	346/665 /787	347/754 /1025
Water pressure drop <sup>3)4)</sup>	kPa	1,0/3,0 /6,0	2,0/5,0 /9,0	4,0/11,0 /18,0	2,0/6,0 /13,0	3,0/10,0 /15,0	51/12,0 /16,3	10,3/15,6 /21,5	2,6/2,8 /2,9	9,2/15,6 /18,4	4,0/16,4 /29,3
<b>Sound levels</b>											
Sound power	dB(A)	42/47/53	44/51/58	45/52/58	46/54/60	47/54/61	46/54/58	46/54/58	46/54/57	47/55/58	48/55/60
<b>Ventilation</b>											
Number of fans		1	1	2	2	3	1	1	2	2	3
Air flow	m <sup>3</sup> /h	90/200/290	140/290/390	190/390/550	230/450/680	250/610/870	120/260/390	180/350/560	240/440/730	260/550/905	280/750/1150
Maximum static pressure	Pa	100	90	120	110	140	90	130	110	140	140
<b>Electrical data</b>											
Power supply	Voltage	V	230	230	230	230	230	230	230	230	230
	Phase		Single phase	Single phase	Single phase	Single phase	Single phase	Single phase	Single phase	Single phase	Single phase
	Frequency	Hz	50	50	50	50	50	50	50	50	50
Consumption	W	14/32/80	22/55/140	26/65/160	33/80/160	38/115/230	6/11/24	7/14/31	8/16/34	13/30/38	14/42/85
Degree of protection	IP	X0	X0	X0	X0	X0	X0	X0	X0	X0	X0
<b>Connections</b>											
Hydraulic connections type		Eurokonus	Eurokonus	Eurokonus	Eurokonus	Eurokonus	Eurokonus	Eurokonus	Eurokonus	Eurokonus	Eurokonus
Hydraulic connections	Inch	3/4	3/4	3/4	3/4	3/4	3/4	3/4	3/4	3/4	3/4
Condensate drainage connection	mm	20	20	20	20	20	20	20	20	20	20
Intake air connection	Base x Height	mm	460 x 100	660 x 100	860 x 100	1060 x 100	1320 x 100	460 x 150	660 x 150	860 x 150	1060 x 150
Return air connection	Base x Height	mm	510 x 100	710 x 100	910 x 100	1110 x 100	1370 x 100	510 x 150	710 x 150	910 x 150	1110 x 150
<b>Dimension and weight</b>											
Dimension	H x W x D	mm	185 x 590 x 575	185 x 790 x 575	185 x 990 x 575	185 x 1190 x 575	185 x 1440 x 575	240 x 590 x 695	240 x 790 x 695	240 x 990 x 695	240 x 1190 x 695
Weight	kg	30	41	45	54	65	32	43	47	56	67

1) Fan standard factory set speeds. 2) According to Eurovent standard. Air: 27 °C DB/19 °C WB, chilled water: 7 °C/12 °C. 3) Pressure loss by corresponding nominal flow. 4) According to Eurovent standard. Air: 20 °C, hot water: 45 °C/40 °C.

Configure your own Aquarea Air Smart fan coil – Ducted thin / ducted unit

Fan coil with wall-mounted control		
Left-hand piping	Right-hand piping	
P-FTN15005-RE	P-FTN15R05-RE	
P-FTN20005-RE	P-FTN20R05-RE	
P-FTN25005-RE	P-FTN25R05-RE	
P-FTN35005-RE	P-FTN35R05-RE	
P-FTN45005-RE	P-FTN45R05-RE	
P-FSN20005-RE	P-FSN20R05-RE	
P-FSN25005-RE	P-FSN25R05-RE	
P-FSN35005-RE	P-FSN35R05-RE	
P-FSN45005-RE	P-FSN45R05-RE	
P-FSN55005-RE	P-FSN55R05-RE	
Control (required, to be ordered separately)	With Modbus	PCZ-EEB749
	With integrated Wi-Fi	PCZ-EFB749

Valve kits (optional)	
PCZ-V30361	3 way valve with motor

Fan coil with PCB for analog control (0-10 V)		
Left-hand piping	Right-hand piping	
P-FTN15005-JE	P-FTN15R05-JE	
P-FTN20005-JE	P-FTN20R05-JE	
P-FTN25005-JE	P-FTN25R05-JE	
P-FTN35005-JE	P-FTN35R05-JE	
P-FTN45005-JE	P-FTN45R05-JE	
P-FSN20005-JE	P-FSN20R05-JE	
P-FSN25005-JE	P-FSN25R05-JE	
P-FSN35005-JE	P-FSN35R05-JE	
P-FSN45005-JE	P-FSN45R05-JE	
P-FSN55005-JE	P-FSN55R05-JE	

Valve kits (optional)	
PCZ-V20139	2 way valve with motor

## Aquarea Air Smart fan coil – Ducted multi zone thin / ducted multi zone

Fan coil ducted units with cooling and heating.

Cooling capacity: 0,5 to 7,6 kW.

Heating capacity: 0,5 to 8,52 kW.

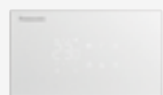

Optional controller. Wall-mounted control with Modbus. PCZ-EEB749

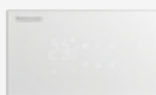

Optional controller. Wall-mounted control with integrated Wi-Fi. PCZ-EFB749



Optional controller. PCB for analog control (0-10 V).

CHECK PAGE 115 FOR A WIDER SELECTION OF ACCESSORIES

### The range at a glance

- Multi zone management (2-5 zones)
- Slim profile, only 185 mm for the thin version
- DC Inverter – maximising comfort and energy savings
- Modulated air flow
- Quiet operation
- Centrifugal fan with single motor impeller

### Possible configurations

- Left or right water connections
- 2 or 3 way valves as accessories
- Wall-mounted control or PCB for analog input (0-10 V)

### The ducted Smart fan coil unit with integrated multi zone management.

#### High installation flexibility.

Single air outlet per zone.

Multiple air outlets per zone.



Example: 3 air outlets for 3 independent zones.



Example: 3 air outlets for 2 independent zones. Zone 1 with dual channel. Zone 2 with single channel.

### Multi zone management

Thanks to integrated multi zone management and the use of forward-bladed centrifugal brushless EC multi-fans, the fan coil ducted multi zone allow independent management of the different thermal zones, resulting in benefits in terms of efficiency, comfort and quietness.



**1 | Air supply plate.**  
Built-in air supply plate, number of outlets depending on unit size.

- P-FTQ30/P-FSQ30: 2 outlets DN 160 mm
- P-FTQ45/P-FSQ45: 3 outlets DN 160 mm
- P-FTQ60/P-FSQ60: 4 outlets DN 160 mm
- P-FTQ65/P-FSQ75: 5 outlets DN 160 mm

**2 | Fans.**  
Integrated multi-fans for independent management of the different zones.

**3 | Horizontal condensate tray.**  
Allows the collection of condensate if the unit is installed horizontally.

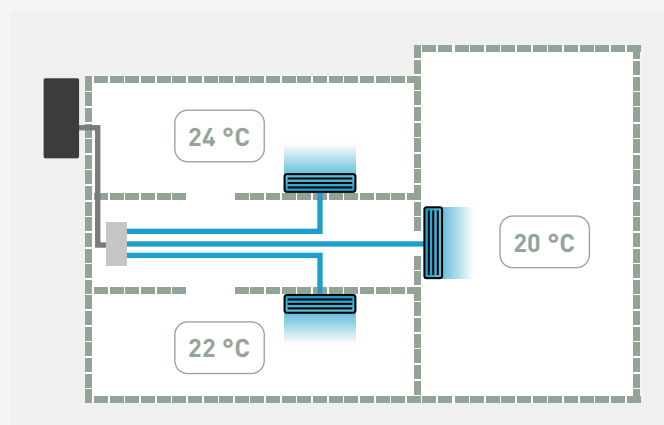

Technical performance

		Ducted multi zone thin				Ducted multi zone				
Model <small>(the complete model codes are shown in the table below)</small>		P-FTQ30	P-FTQ45	P-FTQ60	P-FTQ65	P-FSQ30	P-FSQ45	P-FSQ60	P-FSQ75	
<b>Fan speed</b> <sup>1)</sup>		<b>Min / Med / Max</b>	<b>Min / Med / Max</b>	<b>Min / Med / Max</b>	<b>Min / Med / Max</b>	<b>Min / Med / Max</b>	<b>Min / Med / Max</b>	<b>Min / Med / Max</b>	<b>Min / Med / Max</b>	
Total cooling capacity <sup>2)</sup>	kW	1,10/1,97 /3,02	1,16/2,97 /4,40	2,02/3,68 /5,70	2,09/4,15 /6,40	0,47/3,80 /3,23	0,66/3,77 /4,57	0,85/4,87 /5,88	1,06/6,31 /7,61	
Sensible capacity <sup>2)</sup>	kW	0,76 /1,37 /2,15	0,79/2,09 /3,16	1,45/2,67 /4,10	1,61/3,08 /4,60	0,33/2,70 /2,22	0,48/2,62 /3,16	0,63/3,40 /4,10	0,78/4,32 /5,20	
Single zone cooling capacity <sup>2)</sup>	kW	0,49/1,30 /1,70	0,49/1,30 /1,70	0,49/1,30 /1,70	0,49/1,30 /1,70	-/-/2,10	-/-/2,10	-/-/2,10	-/-/2,10	
Single zone sensible capacity <sup>2)</sup>	kW	0,31/0,89 /1,23	0,31/0,89 /1,23	0,31/0,89 /1,23	0,31/0,89 /1,23	-/-/1,50	-/-/1,50	-/-/1,50	-/-/1,50	
Water flow <sup>2)</sup>	l/h	190/338 /530	200/510 /800	346/630 /1030	358/713 /1220	80/651 /553	113/647 /782	146/834 /1008	182,3/1081 /1304	
Water pressure drop <sup>2)3)</sup>	kPa	4,0/11,0/22,0	2,0/9,0/18,0	3,0/9,0/18,0	1,0/4,0/9,0	1,8/29,0/54,1	1,2/25,7/36,4	1,0/20,2/28,5	1,6/37,3/52,6	
Heating capacity <sup>4)</sup>	kW	1,15/2,11 /3,30	1,71/3,19 /4,90	-/5,76/6,30	2,67/4,75 /7,65	0,45/3,90 /3,61	0,68/4,16 /5,08	0,90/5,42 /6,59	1,13/6,87 /8,37	
Single zone heating capacity <sup>4)</sup>	kW	0,42/1,29 /1,85	0,42/1,29 /1,85	0,42/1,29 /1,85	0,42/1,29 /1,85	-/-/2,20	-/-/2,20	-/-/2,20	-/-/2,20	
Water flow <sup>4)</sup>	l/h	200/368 /560	296/554 /800	391/699 /1110	464/826 /1305	80/688 /636	120/748 /914	159/975 /1189	199/1230 /1502	
Water pressure drop <sup>3)4)</sup>	kPa	4,0/13,0/25,0	3,0/10,0/19,0	3,0/10,0/18,0	2,0/5,0/10,0	1,4/29,0/61,2	1,1/28,9/42,3	0,9/23,1/33,7	1,5/41,4/60,6	
<b>Sound levels</b>										
Sound power	dB(A)	40/49/58	42/50/59	42/52/61	43/53/62	-/-/60	-/-/61	-/-/62	-/-/64	
<b>Ventilation</b>										
Number of fans		2	3	4	5	2	3	4	5	
Air flow	m <sup>3</sup> /h	145/290 /480	215/435 /720	288/576 /960	360/720 /1200	60/600 /810	90/900 /1215	120/1200 /1620	150/1500 /2025	
Single zone air flow	m <sup>3</sup> /h	50/160/240	50/160/240	50/160/240	50/160/240	60/205/300	60/205/300	60/205/300	60/205/300	
Maximum static pressure	Pa	100	100	100	100	100	100	100	100	
<b>Electrical data</b>										
Power supply	Voltage	V	230	230	230	230	230	230	230	
	Phase		Single phase	Single phase	Single phase	Single phase	Single phase	Single phase	Single phase	
	Frequency	Hz	50	50	50	50	50	50	50	
Consumption	W	31/66/130	45/102/195	61/135/260	76/162/325	53/140/178	159/420/534	212/560/712	265/700/890	
Degree of protection	IP	X0	X0	X0	X0	X0	X0	X0	X0	
<b>Connections</b>										
Hydraulic connections type		Eurokonus	Eurokonus	Eurokonus	Eurokonus	Eurokonus	Eurokonus	Eurokonus	Eurokonus	
Hydraulic connections	Inch	3/4	3/4	3/4	3/4	3/4	3/4	3/4	3/4	
Condensate drainage connection	mm	20	20	20	20	20	20	20	20	
Intake air connection	mm	160	160	160	160	160	160	160	160	
Return air connection	Base x Height	mm	630 x 100	830 x 100	1030 x 100	1320 x 100	630 x 150	830 x 150	1030 x 150	
<b>Dimension and weight</b>										
Dimension	H x W x D	mm	185 x 790 x 575	185 x 990 x 575	185 x 1190 x 575	185 x 1440 x 575	240 x 790 x 695	240 x 990 x 695	240 x 1190 x 695	240 x 1440 x 695
Weight	kg	41	45	54	56	43	47	56	67	

1) Fan standard factory set speeds. 2) According to Eurovent standard. Air: 27 °C DB/19 °C WB, chilled water: 7 °C/12 °C. 3) Pressure loss by corresponding nominal flow. 4) According to Eurovent standard. Air: 20 °C, hot water: 45 °C/40 °C.

Configure your own Aquarea Air Smart fan coil – Ducted multi zone thin / ducted multi zone unit

Fan coil with wall-mounted control		
Left-hand piping	Right-hand piping	
P-FTQ30005-RE	P-FTQ30R05-RE	
P-FTQ45005-RE	P-FTQ45R05-RE	
P-FTQ60005-RE	P-FTQ60R05-RE	
P-FTQ65005-RE	P-FTQ65R05-RE	
P-FSQ30005-RE	P-FSQ30R05-RE	
P-FSQ45005-RE	P-FSQ45R05-RE	
P-FSQ60005-RE	P-FSQ60R05-RE	
P-FSQ75005-RE	P-FSQ75R05-RE	
Control (required, to be ordered separately)	With Modbus	PCZ-EEB749
	With integrated Wi-Fi	PCZ-EFB749

Fan coil with PCB for analog control (0-10 V)		
Left-hand piping	Right-hand piping	
P-FTQ30005-JE	P-FTQ30R05-JE	
P-FTQ45005-JE	P-FTQ45R05-JE	
P-FTQ60005-JE	P-FTQ60R05-JE	
P-FTQ65005-JE	P-FTQ65R05-JE	
P-FSQ30005-JE	P-FSQ30R05-JE	
P-FSQ45005-JE	P-FSQ45R05-JE	
P-FSQ60005-JE	P-FSQ60R05-JE	
P-FSQ75005-JE	P-FSQ75R05-JE	

Valve kits (optional)	
PCZ-V30361	3 way valve with motor

Valve kits (optional)	
PCZ-V20139	2 way valve with motor

### Flex Air Smart fan coil – Wall-mounted DC fan – FK1

Fan coil wall units with new stylish design and nanoe™ X (Mark 3).

Cooling capacity: 1,9 to 5,2 kW.

Heating capacity: 2,2 to 5,3 kW.

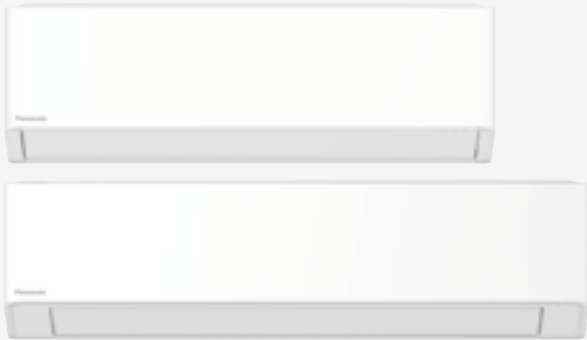

Optional 

  
nanoe™ X as a standard.



Optional controller. CONEX Series, white or black. CZ-RTC6W/BL/BLW2 or CZ-RTC6/BL/BLW2



Optional controller. Wired remote controller with Econavi function. CZ-RTC5B



Optional controller. Infrared remote controller for wall-mounted. CZ-RWS3



Optional controller. Wired remote controller. PAW-FC-903EC

SEE PAGE 572 FOR MORE DETAILS ABOUT FAN COIL CONTROLLERS

### Operating limits

Entering water temperature (without glycol).

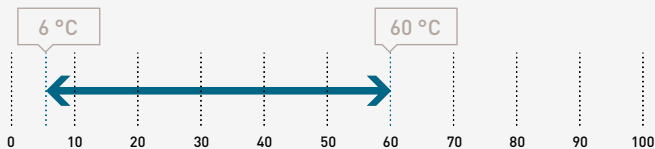

Indoor air temperature.

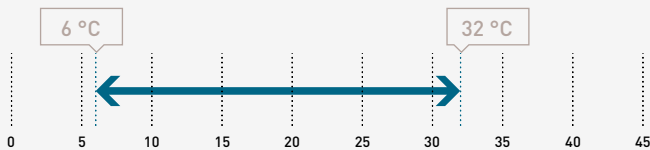

Maximum operating pressure: 10 bar.

### The range at a glance

- Versions (2-pipes): with and without 3 way valve
- 6 sizes
- DC fan for better efficiency and control
- Air flow from 360 to 1045 m<sup>3</sup>/h
- nanoe™ X technology to improve protection 24/7
- G1 cleanable air filter
- S-Link available - compatible with Panasonic controllers

### Advantages

- Ideal for commercial and residential applications in combination with Aquarea Heat Pumps
- Modern stylish design with flat face and compact size
- Inner and outer motorized louvers with five-step positions
- Six directional piping outlet to adapt to different installations
- nanoe™ X (Generator Mark 3: 48 trillion hydroxyl radicals/sec) as standard for better indoor air quality
- Quieter operation than AC fan models
- Very easy servicing through a removable front panel
- Cleanable synthetic-type air filter
- Compatibility with a wide range of controllers

### Accessories supplied loose

CZ-RWS3 – infrared remote controller
CZ-RTC5B – wired remote controller with Econavi function
CZ-RTC6W – CONEX wired remote controller (non-wireless), white
CZ-RTC6WBL – CONEX wired remote controller with Bluetooth®, white
CZ-RTC6WBLW2 – CONEX wired remote controller with Wi-Fi and Bluetooth®, white
CZ-RTC6 – CONEX wired remote controller (non-wireless), black
CZ-RTC6BL – CONEX wired remote controller with Bluetooth®, black
CZ-RTC6BLW2 – CONEX wired remote controller with Wi-Fi and Bluetooth®, black
CZ-CENSC1 – Econavi energy saving sensor
PAW-FC-903EC – wired remote controller
CZ-64ESMC3 – system controller for 64 indoor units
CZ-256ESMC3 – centralised controls up to 256 indoor units
CZ-ANC3 – central ON / OFF controller, up to 16 groups, 64 indoor units

## Technical performance

Flex Air Smart fan coil – Wall-mounted DC fan – FK1	Standard model	S-19FK1E0	S-24FK1E0	S-27FK1E0	S-36FK1E0	S-45FK1E0	S-52FK1E0
	With 3 way valve	S-19FK1E	S-24FK1E	S-27FK1E	S-36FK1E	S-45FK1E	S-52FK1E
<b>Fan speed <sup>1)</sup></b>		<b>Min / Med / Max</b>	<b>Min / Med / Max</b>	<b>Min / Med / Max</b>	<b>Min / Med / Max</b>	<b>Min / Med / Max</b>	<b>Min / Med / Max</b>
<b>2-pipes</b>							
Total cooling capacity <sup>2)</sup>	kW	1,40/1,65/1,90	1,92/2,17/2,41	2,02/2,51/2,73	2,65/3,11/3,61	3,02/3,78/4,50	4,03/4,63/5,23
Sensible capacity <sup>2)</sup>	kW	1,10/1,35/1,54	1,50/1,71/1,91	1,59/2,00/2,19	2,12/2,52/2,98	2,25/2,84/3,41	3,04/3,51/4,02
Water flow <sup>2)</sup>	l/h	250/295/342	344/389/432	362/449/489	473/556/648	539/680/809	724/830/908
Water pressure drop (coil only)	kPa	4/6/8	8/11/13	9/14/17	16/22/30	19/30/42	34/44/56
Water pressure drop (with 3 way valve) <sup>2)</sup>	kPa	18/23/29	25/29/36	26/39/44	42/57/74	53/80/110	90/112/142
Air flow <sup>2)</sup>	m <sup>3</sup> /h	230/276/345	324/361/416	343/434/480	462/572/710	488/603/753	637/753/879
Input power <sup>2)</sup>	W	10/11/12	12/12/14	12/14/16	15/19/26	13/17/22	18/23/29
Sound pressure Lp <sup>2) 3)</sup>	dB(A)	27	26	29	39	35	40
Sound power Lw <sup>2)</sup>	dB(A)	40	39	42	49	47	52
Heating capacity <sup>4)</sup>	kW	1,59/1,92/2,23	1,97/2,39/2,72	2,18/2,64/3,01	2,89/3,48/4,03	3,09/4,21/5,13	4,03/4,72/5,33
Water flow <sup>4)</sup>	l/h	281/329/381	339/417/481	379/463/533	508/614/715	544/740/898	710/827/931
Water pressure drop (coil only)	kPa	5/8/10	8/12/16	10/15/20	18/27/36	19/36/52	33/44/56
Water pressure drop (with 3 way valve) <sup>4)</sup>	kPa	18/24/30	23/31/39	25/36/47	42/60/72	46/82/118	74/97/128
Air flow <sup>4)</sup>	m <sup>3</sup> /h	253/314/406	343/425/489	379/471/545	517/646/765	511/730/925	672/810/960
Input power <sup>4)</sup>	W	10/12/13	12/14/15	13/15/17	16/21/28	14/21/32	19/26/35
Sound pressure Lp <sup>3) 4)</sup>	dB(A)	24/27/29	22/26/29	23/28/32	30/36/41	28/36/42	34/39/43
Sound power Lw <sup>4)</sup>	dB(A)	37/40/43	37/39/42	38/42/45	44/49/55	42/47/51	48/52/56
<b>Water connections</b>							
Connection type		Female gas threaded	Female gas threaded	Female gas threaded	Female gas threaded	Female gas threaded	Female gas threaded
	Inch	1/2	1/2	1/2	1/2	1/2	1/2
nanoe X Generator		Mark 3	Mark 3	Mark 3	Mark 3	Mark 3	Mark 3
<b>Dimension and weight</b>							
Dimension	HxWxD	mm	295x890x244	295x890x244	295x890x244	295x890x244	295x1060x249
Weight		kg	12	13	13	13	14

## Energy efficiency class <sup>5)</sup>

Flex Air Smart fan coil – Wall-mounted DC fan – FK1								
2-pipes	FCEER <sup>2)</sup>	A to E	B	B	B	B	A	
	$\eta_{s,c}$	%	144,2	166,9	172,1	169,3	226,8	213,0
	FCCOP <sup>4)</sup>	A to E	B	B	B	B	B	
	$\eta_{s,h}$	%	160,0	167,0	170,5	173,4	208,5	198,0

1) Fan standard factory set speeds. 2) According to Eurovent standard. Air: 27 °C DB/19 °C WB, chilled water: 7 °C/12 °C. 3) The sound pressure of the indoor unit shows the value measured of a position of 1 m in front of the main body and 0,8 m below the unit. The sound pressure is measured in accordance with JIS C 9612. 4) According to Eurovent standard. Air: 20 °C, hot water: 45 °C/40 °C. 5) According to Eurovent.

## Flex Air Smart fan coil – Wall-mounted.

### Great flexibility and improved air quality for your projects.

Flex Air Smart fan coil –  
Wall-mounted unit is the first  
Panasonic water fan coil integrated  
with nanoe™ X technology for  
improved air quality and compatible  
with individual and centralised  
PACi NX/VRF controls.



**nanoe™ X**



**COMPATIBILITY WITH  
PACi NX/VRF CONTROLS**



**QUIET OPERATION**



**STYLISH DESIGN**



**MOTORIZED LOUVERS**



**COMPACT FOOTPRINT**



ErP compliant following COMMISSION REGULATION (EU) 2016/2281.



**NEW! Flex Air Smart fan coil – Medium static pressure duct DC fan – FF1****Fan coil medium static pressure ductable units with nanoe™ X (Mark 3).****Cooling capacity: 2,3 to 9,3 kW.****Heating capacity: 2,7 to 9,8 kW.**

NEW

**The range at a glance**

- Versions: 2-pipe and 4-pipe
- 7 sizes
- DC fan for better efficiency and control
- Air flow from 590 to 1500 m<sup>3</sup>/h
- External static pressure: 120 Pa
- nanoe™ X technology to improve protection 24/7
- S-Link available - compatible with Panasonic controllers

**Advantages**

- Ideal for commercial and residential applications with a low height for all sizes
- nanoe™ X (Generator Mark 3: 48 trillion hydroxyl radicals/sec) as standard for better indoor air quality
- Efficiency class: A in cooling and heating modes for all sizes
- Flexible hydraulic connection right/left and right electrical connection
- Air return and discharge configuration: In line (I) or from the same side (U)
- Different aerualic plenum configurations: rectangular or Circular Ø200 mm
- Compatibility with a wide range of controllers
- G1 cleanable synthetic-type air filter
- Very easy servicing

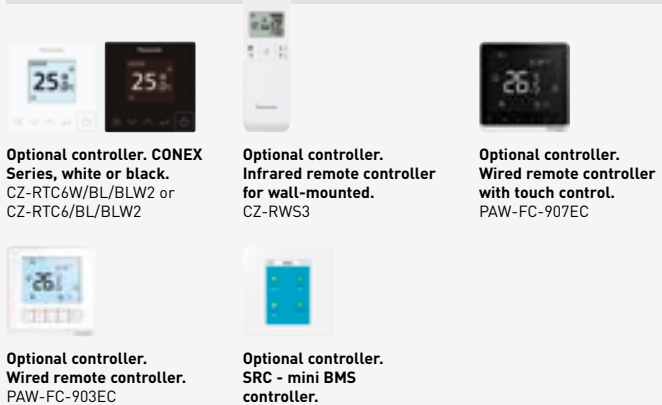

SEE PAGE 572 FOR MORE DETAILS ABOUT FAN COIL CONTROLLERS

**Operating limits**

Entering water temperature (without glycol).

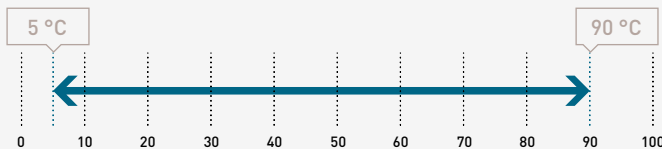

Indoor air temperature.

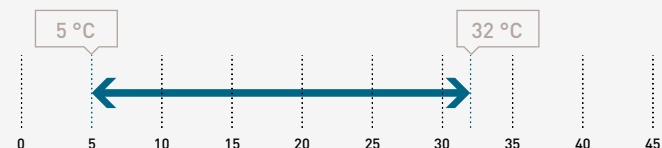
**AC SELECT.****Smart and user-friendly selection tool.**Configure your air conditioning solution at required conditions: <https://acselect.panasonic.eu/>

## Technical performance

Flex Air Smart fan coil*			S-23FF1E	S-28FF1E	S-40FF1E	S-50FF1E	S-70FF1E	S-80FF1E	S-93FF1E
<b>Fan speed</b> <sup>1)</sup>			<b>Max</b>	<b>Max</b>	<b>Max</b>	<b>Max</b>	<b>Max</b>	<b>Max</b>	<b>Max</b>
<b>2-pipes</b>									
Total cooling capacity <sup>2)</sup>	kW		2,30	2,80	4,00	5,00	7,00	8,00	9,30
Heating capacity <sup>3)</sup>	kW		2,70	3,30	4,20	5,20	7,50	8,30	9,80
<b>4-pipes</b>									
Total cooling capacity <sup>2)</sup>	kW		2,14	2,71	3,74	4,75	6,87	7,31	8,71
Heating capacity <sup>4)</sup>	kW		4,95	5,96	5,16	7,10	8,56	10,16	11,36
<b>Ventilation</b>									
Air flow <sup>5)</sup>	2-pipes	m <sup>3</sup> /h	590	680	576	980	1230	1180	1500
	4-pipes	m <sup>3</sup> /h	420	600	460	780	1110	1110	1360
External static pressure	Pa		120	120	120	120	120	120	120
<b>Water connections</b>									
Connection type			Female gas threaded	Female gas threaded	Female gas threaded	Female gas threaded	Female gas threaded	Female gas threaded	Female gas threaded
Water connections	Inch		1/2	1/2	1/2	3/4	3/4	3/4	3/4
<b>Dimension and weight</b>									
Dimension	H x W x D	mm	250 x 800 x 730	250 x 800 x 730	250 x 800 x 730	250 x 1000 x 730	250 x 1000 x 730	250 x 1400 x 730	250 x 1400 x 730
Weight		kg	26	26	33	33	33	47	47

## Energy efficiency class<sup>6)</sup>

Flex Air Smart fan coil									
2-pipes	FCEER	A to E	A	A	A	A	A	A	A
	FCCOP	A to E	A	A	A	A	A	A	A
4-pipes	FCEER	A to E	A	A	A	A	A	A	A
	FCCOP	A to E	A	A	A	A	A	A	A

1) Fan standard factory set speeds (voltage). 2) According to Eurovent standard. Air: 27 °C DB/19 °C WB, chilled water: 7 °C/12 °C. 3) According to Eurovent standard. Air: 20 °C, hot water: 45 °C/40 °C.

4) According to Eurovent standard. Air: 20 °C, hot water: 65 °C/55 °C. 5) According to Eurovent 6/10 (air flow test method) and 8/12 (sound test method). 6) According to Eurovent. \*Available in Summer 2026.

### Accessories and options

2W or 3W – 2 way or 3 way valves

CB – Circuit breakers

PUMP – Drain pump

EH – Electric heaters (from 500 W to 2500 W)

Fresh air intake Ø 100 mm

FH – Fuse holder

### Accessories and options

G2 / G3 / G4 filters

Other speeds configuration (standard factory set speeds in technical table)

Many air inlet/outlet configurations

HL/ER – Hydraulic left – electric right

HR/ER – Hydraulic right – electric right

### Accessories supplied loose

SRC – Smart remote control – Mini building management system (only with Modbus RTU)

CZ-RTC6W – CONEX wired remote controller (non-wireless), white

CZ-RTC6WBL – CONEX wired remote controller with Bluetooth®, white

CZ-RTC6WBLW2 – CONEX wired remote controller with Wi-Fi and Bluetooth®, white

CZ-RTC6 – CONEX wired remote controller (non-wireless), black

### Accessories supplied loose

CZ-RTC6BL – CONEX wired remote controller with Bluetooth®, black

CZ-RTC6BLW2 – CONEX wired remote controller with Wi-Fi and Bluetooth®, black

CZ-RWS3 + CZ-RWRC3 – Infrared remote controller and receiver

PAW-FC-907EC – Wired remote controller with touch control

PAW-FC-903EC – Wired remote controller

KIT REMOTE SENSOR – Remote sensor for ducted unit

**Flex Air fan coil – Comfort AC fan**

**Fan coil floor and ceiling units with cooling and heating.**  
**Cooling capacity: 0,6 to 6,9 kW.**  
**Heating capacity: 0,6 to 7,4 kW.**



Optional controller.  
WRC remote control.



Optional controller.  
SRC - mini BMS controller.



Optional controller.  
Electronic controller  
TControl POD glass.



Optional controller.  
Electronic controller  
TControl EASY 3S.



Optional controller.  
Wired remote controller  
with touch control.  
PAW-FC-907AC



Optional controller.  
Wired remote controller.  
PAW-FC-903AC



Optional controller.  
Advanced wired remote controller.  
PAW-FC-RC1

SEE PAGE 572 FOR MORE DETAILS ABOUT FAN COIL CONTROLLERS

**Operating limits**

Entering water temperature (without glycol).

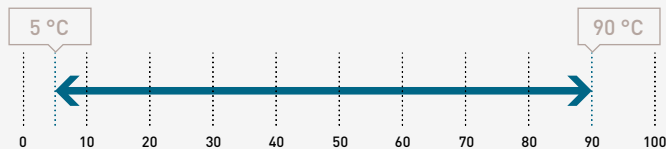

Indoor air temperature.

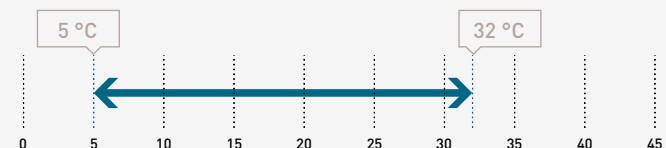

**The range at a glance**

- Versions: 2-pipes, 2-pipes + electric heater and 4-pipes
- 7 sizes
- 5-speed AC fan - standard factory set speeds: S1,S3,S5
- Air flow from 94 to 1064 m³/h
- Configuration: universal installation units (vertical or horizontal) with or without cabinet
- Left or right water connections
- Many air inlet/outlet configurations
- G2 air filter (G3 as an option)

**Advantages**

- Silent units
- New casing design for an increased robustness
- Harmonious and aesthetic RAL 9003 painted cabinet
- Valves, condensate drain pan and drain pump factory mounted
- 100% factory tested

**Accessories and options**

- 2W or 3W – 2 way or 3 way valves
- 4-pipes kit (additional coil)
- CB – Circuit breakers
- PUMP – Drain pump
- EH – Electric heaters (from 500 W to 2500 W)
- FC/FCG – Feet with/without grid
- FH – Fuse holders
- G3 filter
- DG – Horizontal or vertical drain guard (with valve)
- Many air inlet/outlet configurations
- C/O – Electromechanical sensor for automatic changeover

**AC SELECT.**

**Smart and user-friendly selection tool.**

Configure your air conditioning solution at required conditions: <https://acselect.panasonic.eu/>



## Technical performance

Flex Air fan coil – Comfort AC fan			P-FC10	P-FC20	P-FC30	P-FC40	P-FC50	P-FC60	P-FC70
<b>Fan speed</b> <sup>1)</sup>			<b>Min / Med / Max</b>	<b>Min / Med / Max</b>	<b>Min / Med / Max</b>	<b>Min / Med / Max</b>	<b>Min / Med / Max</b>	<b>Min / Med / Max</b>	<b>Min / Med / Max</b>
<b>2-pipes</b>									
Total cooling capacity <sup>2)</sup>	kW		0,66/1,00/1,45	0,61/0,96/1,38	0,95/1,88/2,37	1,14/2,28/3,02	1,71/3,16/4,64	2,57/4,33/5,53	3,24/5,84/6,91
Sensible capacity <sup>2)</sup>	kW		0,48/0,77/1,05	0,43/0,70/1,02	0,78/1,44/1,80	0,83/1,66/2,23	1,24/2,23/3,27	1,81/3,14/4,25	2,26/4,11/4,85
Water flow <sup>2)</sup>	L/h		114/172/250	105/165/238	164/324/408	196/393/520	295/544/799	443/746/953	558/1006/1190
Water pressure drop <sup>2)3)</sup>	kPa		9,17/19,5/39,1	2,65/4,62/7,43	5,8/17,6/26,3	17,0/21,5/35,2	7,5/22,8/47,1	12,6/33,9/54,4	4,4/13,9/19,4
Heating capacity <sup>4)</sup>	kW		0,63/1,18/1,71	0,63/1,03/1,53	1,00/1,86/2,49	1,14/2,28/3,18	1,79/3,47/4,81	2,45/4,22/5,63	3,45/6,27/7,41
Water flow <sup>4)</sup>	L/h		109/203/295	109/177/264	172/320/429	196/393/548	308/598/829	422/727/970	594/1080/1276
Water pressure drop <sup>3)4)</sup>	kPa		5,9/17,3/33,8	2,76/5,06/8,54	5,8/16,2/27,0	5,0/15,6/28,1	6,1/20,7/38,5	18,6/52,4/91,4	4,9/16,0/22,3
<b>4-pipes</b>									
Total cooling capacity <sup>2)</sup>	kW		0,63/0,88/1,24	0,87/1,34/1,73	0,91/1,80/2,28	0,98/2,14/2,85	1,57/2,88/4,13	2,60/4,39/5,61	3,17/5,62/6,58
Sensible capacity <sup>2)</sup>	kW		0,46/0,67/0,91	0,65/1,02/1,36	0,75/1,39/1,74	0,71/1,57/2,10	1,14/2,04/2,92	1,82/3,18/4,28	2,21/3,96/4,62
Water flow <sup>2)</sup>	L/h		109/152/214	150/231/298	157/310/393	169/369/491	270/496/711	448/756/966	546/968/1133
Water pressure drop <sup>2)3)</sup>	kPa		7,6/13,9/26,3	2,33/4,44/6,64	2,8/8,6/13,1	5,8/20,5/33,6	3,9/11,6/22,8	10,2/27,7/44,5	5,3/16,2/22,1
Heating capacity <sup>5)</sup>	kW		0,63/1,00/1,41	1,00/1,40/1,68	1,28/1,81/2,13	1,22/2,21/2,85	2,01/3,19/4,08	2,71/4,24/5,33	3,65/5,00/5,90
Water flow <sup>5)</sup>	L/h		54/86/121	86,1/121/145	110/156/183	105/190/245	173/275/351	233/365/459	314/431/508
Water pressure drop <sup>3)5)</sup>	kPa		1,2/2,1/3,3	1,15/2,2/3,12	2,8/4,7/6,1	5,1/13,9/21,8	5,7/12,5/19,4	11,6/24,8/37	35,4/60,7/81,2
<b>Sound levels</b>									
Sound power	2-pipes	dB(A)	33/40/49	31/43/50	30/45/52	43/47/51	34/43/56	38/51/58	43/56/61
	4-pipes	dB(A)	33/40/49	31/43/50	30/45/52	33/44/51	34/46/56	38/51/58	43/56/61
Sound pressure <sup>6)</sup>	2-pipes	dB(A)	24/31/40	22/34/41	21/36/43	21/35/42	25/37/47	29/42/49	34/47/52
	4-pipes	dB(A)	24/31/40	22/34/41	21/36/43	21/35/42	25/37/47	29/42/49	34/47/52
NR <sup>6)</sup>	2-pipes		19/26/35	17/29/36	16/31/38	16/30/37	20/32/42	24/37/44	29/42/47
	4-pipes		19/26/35	17/29/36	16/31/38	16/30/37	20/32/42	24/37/44	29/42/47
<b>Ventilation</b>									
Number of fans			1	1	1	2	2	2	2
Air flow	2-pipes	m <sup>3</sup> /h	94/190/283	68/104/196	138/274/390	270/311/417	253/486/716	350/640/933	480/893/1064
	4-pipes	m <sup>3</sup> /h	95/168/253	89/161/241	132/263/369	148/335/467	242/466/671	334/614/885	470/859/1012
Filter			G2	G2	G2	G2	G2	G2	G2
<b>Electrical data</b>									
Power supply	Voltage	V	230	230	230	230	230	230	230
	Phase		Single phase	Single phase	Single phase	Single phase	Single phase	Single phase	Single phase
	Frequency	Hz	50/60	50/60	50/60	50/60	50/60	50/60	50/60
Consumption	2-pipes	W	13/24/36	13/18/31	16/37/45	15/37/56	28/55/72	37/75/105	53/100/147
	4-pipes	W	13/24/36	11/18/28	16/37/44	15/37/55	28/54/70	37/74/104	53/99/145
Electric heater	W		500	500	500/1000	1250	1250/2500	1250/2500	1250/2500
<b>Water connections</b>									
Connection type			Female gas threaded	Female gas threaded	Female gas threaded	Female gas threaded	Female gas threaded	Female gas threaded	Female gas threaded
2 or 4-pipes	Cooling	Inch	½	½	½	½	½	½	¾
4-pipes	Heating	Inch	½	½	½	½	½	½	½
<b>Dimension</b>									
With cabinet - without feet	H x W x D	mm	477 x 766 x 225	477 x 766 x 225	477 x 951 x 225	477 x 1136 x 225	477 x 1321 x 225	477 x 1506 x 225	575 x 1319 x 225
Without cabinet	H x W x D	mm	430 x 570 x 220	430 x 570 x 220	430 x 753 x 220	430 x 938 x 220	430 x 1122 x 220	430 x 1307 x 220	530 x 1121 x 220
<b>Weight</b>									
With cabinet	2 / 4-pipes	kg	19/20	19/20	22/23	27/29	30/32	35/37	35/37
Without cabinet	2 / 4-pipes	kg	13/14	13/14	15/16	20/22	22/24	26/28	27/29

## Energy efficiency class<sup>7)</sup>

Flex Air fan coil – Comfort AC fan									
<b>2-pipes</b>	<b>FCEER</b>	<b>A to E</b>	<b>E</b>	<b>E</b>	<b>D</b>	<b>D</b>	<b>D</b>	<b>D</b>	<b>D</b>
	<b>FCCOP</b>	<b>A to E</b>	<b>E</b>	<b>E</b>	<b>E</b>	<b>E</b>	<b>E</b>	<b>E</b>	<b>E</b>
<b>4-pipes</b>	<b>FCEER</b>	<b>A to E</b>	<b>E</b>	<b>D</b>	<b>D</b>	<b>D</b>	<b>E</b>	<b>D</b>	<b>D</b>
	<b>FCCOP</b>	<b>A to E</b>	<b>E</b>	<b>D</b>	<b>D</b>	<b>D</b>	<b>E</b>	<b>E</b>	<b>E</b>

1) Fan standard factory set speeds. 2) According to Eurovent standard. Air: 27 °C DB/19 °C WB, chilled water: 7 °C/12 °C. 3) Pressure loss by corresponding nominal flow. 4) According to Eurovent standard. Air: 20 °C, hot water: 45 °C/40 °C. 5) According to Eurovent standard. Air: 20 °C, hot water: 65 °C/55 °C. 6) Informative data, considering an hypothetical sound attenuation of the room and installation of 9 dB(A). 7) According to Eurovent. \*Standard configuration with left hand hydraulic connection. G2 air filter included as standard.

### Accessories supplied loose

KIT Plogic – Kit Plogic control board
KIT BRC – Kit basic remote control (only with Plogic control board)
KIT WRC – Kit wall-mounted remote control LCD (only with Plogic control board)
KIT MB2 – Kit Plogic Modbus board
Other speeds configuration (standard factory set speeds in technical table)
SRC – Smart remote control – Mini building management system (only with Modbus RTU)
Suspension kit
TCEASY 2P/4P – Kit controller, HMI-integrated, 2-pipe, 4-pipe, AC fan speed

### Accessories supplied loose

TCEASY 2P+C/O – Kit controller, HMI-integrated, 2-pipe + changeover, AC fan speed
TCPOD WHITE (BLACK) 2P/4P – Kit controller, Modbus, HMI-integrated, 2-pipe, 4-pipe, EC fan speed, white (black)
TCPOD WHITE (BLACK) 2P+EH – Kit controller, Modbus, HMI-integrated, 2-pipe+ electrical heater, EC fan speed, white (black)
PAW-FC-907AC – Wired remote controller with touch control
PAW-FC-903AC – Wired remote controller
PAW-FC-RC1 – Advanced wired remote controller



ErP compliant following COMMISSION REGULATION (EU) 2016/2281.



### Flex Air fan coil – Comfort EC fan

Fan coil floor and ceiling units with cooling and heating.

Cooling capacity: 0,5 to 9,1 kW.

Heating capacity: 0,6 to 12,9 kW.



Optional controller.  
WRC remote control.



Optional controller.  
SRC - mini BMS  
controller.



Optional controller.  
Electronic controller  
TControl POD glass.



Optional controller.  
Electronic controller  
TControl EASY 3S.



Optional controller.  
Wired remote controller  
with touch control.  
PAW-FC-907EC



Optional controller.  
Wired remote controller.  
PAW-FC-903EC

SEE PAGE 572 FOR MORE DETAILS ABOUT FAN COIL CONTROLLERS

### Operating limits

Entering water temperature (without glycol).

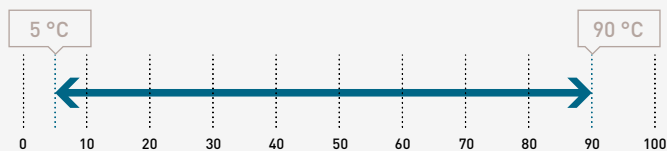

Indoor air temperature.

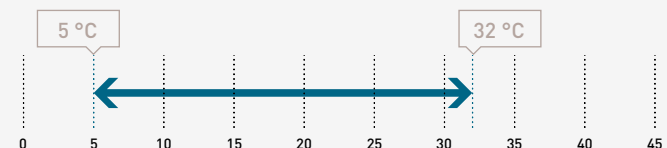

### AC SELECT.

Smart and user-friendly selection tool.

Configure your air conditioning solution at required conditions: <https://acselect.panasonic.eu/>

### The range at a glance

- Versions: 2-pipes, 2-pipes + electric heater and 4-pipes
- 8 sizes
- Low energy consumption EC fan: 100% controllable via a 0-10 V signal or 3 operating speeds
- Air flow from 91 to 1548 m<sup>3</sup>/h
- Configuration: universal installation units (vertical or horizontal) with or without cabinet
- Left or right water connections
- Many air inlet/outlet configurations
- G2 air filter (G3 as an accessory)

### Advantages

- Excellent performances: FCEER and FCCOP up to "A"
- Silent units
- New casing design for an increased robustness
- Harmonious and aesthetic RAL 9003 painted cabinet
- Valves, condensate drain pan and drain pump factory mounted
- 100% factory tested

### Accessories and options

2W or 3W – 2 way or 3 way valves

4-pipes kit (additional coil)

CB – Circuit breakers

PUMP – Drain pump

EH – Electric heaters (from 500 W to 2500 W)

FC/FCG – Feet with/without grid

FH – Fuse holders

G3 filter

DG – Horizontal or vertical drain guard (with valve)

Many air inlet/outlet configurations

C/O – Electromechanical sensor for automatic changeover



## Technical performance

Flex Air fan coil – Comfort EC fan			P-FC10	P-FC20	P-FC30	P-FC40	P-FC50	P-FC60	P-FC70	P-FC80
<b>Fan speed</b> <sup>1)</sup>			<b>Min / Med / Max</b>	<b>Min / Med / Max</b>	<b>Min / Med / Max</b>	<b>Min / Med / Max</b>	<b>Min / Med / Max</b>	<b>Min / Med / Max</b>	<b>Min / Med / Max</b>	<b>Min / Med / Max</b>
<b>2-pipes</b>										
Total cooling capacity <sup>2)</sup>	kW		0,59/1,16/1,96	0,48/0,84/1,31	0,67/1,41/1,83	1,34/2,93/4,19	1,15/2,59/3,41	1,98/4,45/5,24	2,30/4,29/5,91	4,59/6,13/8,36
Sensible capacity <sup>2)</sup>	kW		0,48/1,00/1,76	0,36/0,65/1,03	0,47/1,04/1,34	0,95/2,10/3,00	0,79/1,72/2,25	1,35/3,51/4,02	1,91/4,10/4,96	3,32/4,51/6,28
Water flow <sup>2)</sup>	l/h		102/200/338	105/226/365	141/336/505	231/505/722	231/615/858	341/767/903	439/958/1128	791/1056/1440
Water pressure drop <sup>2)3)</sup>	kPa		7,5/25,7/69,5	1,4/4,3/9,3	5,9/21,8/42,9	6,4/24,3/46,3	4,9/28,7/53,9	7,8/35,8/49,0	2,7/12,6/17,5	14,1/21,4/37,6
Heating capacity <sup>4)</sup>	kW		0,67/1,30/2,31	0,68/1,04/2,52	0,80/1,72/2,66	1,11/2,48/4,46	1,38/3,89/5,19	1,95/4,93/5,82	3,05/5,81/7,17	4,21/5,80/8,43
Water flow <sup>4)</sup>	l/h		115/224/398	117/264/434	138/296/458	191/427/768	238/670/894	336/849/1002	525/1001/1235	798/1101/1598
Water pressure drop <sup>3)4)</sup>	kPa		6,5/20,6/59,1	1,7/5,5/12,4	4,1/14,2/30,4	4,8/18,1/51,9	3,8/25,7/44,6	12,2/70,7/97,5	3,9/13,8/20,9	14,4/23,1/45,6
<b>4-pipes</b>										
Total cooling capacity <sup>2)</sup>	kW		0,40/0,64/1,41	0,57/1,20/2,18	0,75/1,84/2,93	1,03/2,20/3,52	1,17/3,45/4,39	1,69/3,90/4,69	2,44/4,88/6,06	4,44/5,86/9,07
Sensible capacity <sup>2)</sup>	kW		0,30/0,51/1,24	0,43/0,96/1,76	0,55/1,44/2,28	0,73/1,57/2,58	0,92/2,61/3,28	1,12/3,05/3,63	1,83/3,61/4,53	3,20/4,31/6,84
Water flow <sup>2)</sup>	l/h		68,9/109/243	98,2/207/376	129/317/505	177/379/606	202/594/756	291/672/808	420/841/1044	765/1009/1562
Water pressure drop <sup>2)3)</sup>	kPa		5,2/10,5/40,1	1,3/3,8/9,7	4,0/13,7/28,0	9,3/27,8/58,9	2,3/16,2/25,6	4,6/22,0/31,4	3,2/12,3/18,8	18,8/30,6/67,2
Heating capacity <sup>5)</sup>	kW		0,61/1,13/1,87	0,79/1,33/2,09	1,41/2,01/2,77	1,57/2,49/3,62	2,18/3,34/4,10	1,81/4,05/4,81	3,45/4,67/5,53	5,74/7,99/12,90
Water flow <sup>5)</sup>	l/h		52,5/97,3/161	68/115/180	121/173/239	135/214/312	188/288/353	156/349/414	297/402/476	494/688/1111
Water pressure drop <sup>3)5)</sup>	kPa		1,1/2,4/4,8	<1/2,0/4,8	7,9/12,3/18,6	10,9/22,2/41,1	6,5/13,6/19,6	16,1/45,3/57,5	32,2/53,9/72,4	19,2/34,5/83,1
<b>Sound levels</b>										
Sound power	2-pipes	dB(A)	34/47/60	34/47/60	31/50/59	29/44/52	30/51/57	32/54/58	45/57/59	51/56/64
	4-pipes	dB(A)	34/43/54	34/47/60	31/50/59	29/44/56	32/51/57	32/54/58	46/57/64	51/56/64
Sound pressure <sup>6)</sup>	2-pipes	dB(A)	25/38/51	25/38/51	22/41/50	20/35/43	21/42/48	23/45/49	31/45/50	42/47/55
	4-pipes	dB(A)	25/34/45	25/38/51	22/41/50	20/35/43	21/42/48	23/45/49	31/45/50	42/47/55
NR <sup>6)</sup>	2-pipes		20/33/46	20/33/46	17/36/45	15/30/38	16/37/43	18/40/44	26/40/45	37/42/50
	4-pipes		20/29/40	20/33/46	17/36/45	15/30/38	16/37/43	18/40/44	26/40/45	37/42/50
<b>Ventilation</b>										
Number of fans			1	1	1	2	2	2	2	3
Air flow	2-pipes	m <sup>3</sup> /h	108/228/417	98/134/227	119/257/345	170/412/678	203/577/816	245/737/912	350/641/894	500/680/1063
	4-pipes	m <sup>3</sup> /h	76/110/226	84/200/380	123/297/540	148/298/524	185/587/755	205/668/845	329/798/989	660/884/1548
Filter			G2	G2	G2	G2	G2	G2	G2	G2
<b>Electrical data</b>										
Power supply	Voltage	V	230	230	230	230	230	230	230	230
	Phase		Single phase	Single phase	Single phase	Single phase	Single phase	Single phase	Single phase	Single phase
	Frequency	Hz	50/60	50/60	50/60	50/60	50/60	50/60	50/60	50/60
Consumption	2-pipes	W	7/12/41	7/13/41	6/16/42	2/13/43	4/23/46	4/30/54	12/35/77	23/42/108
	4-pipes	W	5/7/17	7/13/40	6/14/40	2/11/39	4/23/44	4/28/52	13/37/84	22/41/116
Electric heater	W		500	500	500/1000	1250	1250/2500	1250/2500	1250/2500	1250/2500
<b>Water connections</b>										
Connection type			Female gas threaded	Female gas threaded	Female gas threaded	Female gas threaded	Female gas threaded	Female gas threaded	Female gas threaded	Female gas threaded
2 or 4-pipes	Cooling	Inch	½	½	½	½	½	½	¾	¾
4-pipes	Heating	Inch	½	½	½	½	½	½	½	½
<b>Dimension</b>										
With cabinet - without feet	H x W x D	mm	477 x 766 x 225	477 x 766 x 225	477 x 951 x 225	477 x 1136 x 225	477 x 1321 x 225	477 x 1506 x 225	575 x 1319 x 225	575 x 1506 x 225
Without cabinet	H x W x D	mm	430 x 570 x 220	430 x 570 x 220	430 x 753 x 220	430 x 938 x 220	430 x 1122 x 220	430 x 1307 x 220	530 x 1121 x 220	530 x 1316 x 220
<b>Weight</b>										
With cabinet	2 / 4-pipes	kg	19/20	19/20	22/23	27/29	30/32	35/37	35/37	47/49
Without cabinet	2 / 4-pipes	kg	13/14	13/14	15/16	20/22	22/24	26/28	27/29	38/40

## Energy efficiency class<sup>7)</sup>

Flex Air fan coil – Comfort EC fan										
2-pipes	FCEER	A to E	C	D	B	A	A	A	B	B
	FCCOP	A to E	D	D	C	B	A	B	B	C
4-pipes	FCEER	A to E	C	C	B	A	B	B	B	A
	FCCOP	A to E	C	C	B	A	B	B	B	A

1) Fan standard factory set speeds (voltage). 2) According to Eurovent standard. Air: 27 °C DB/19 °C WB, chilled water: 7 °C/12 °C. 3) Pressure loss by corresponding nominal flow. 4) According to Eurovent standard. Air: 20 °C, hot water: 45 °C/40 °C. 5) According to Eurovent standard. Air: 20 °C, hot water: 65 °C/55 °C. 6) Informative data, considering a hypothetical sound attenuation of the room and installation of 9 dB(A). 7) According to Eurovent. \*Standard configuration with left hand hydraulic connection. G2 air filter included as standard.

### Accessories supplied loose

KIT Plogic – Kit Plogic control board
KIT BRC – Kit basic remote control (only with Plogic control board)
KIT WRC – Kit wall-mounted remote control LCD (only with Plogic control board)
KIT MB2 – Kit Plogic Modbus board
Other speeds configuration (standard factory set speeds in technical table)
SRC – Smart remote control – Mini building management system (only with Modbus RTU)
Suspension kit
TCEASY 2P/4P – Kit controller, HMI-integrated, 2-pipe, 4-pipe, AC fan speed

### Accessories supplied loose

TCEASY 2P+C/O – Kit controller, HMI-integrated, 2-pipe + changeover, AC fan speed
TCPOD WHITE (BLACK) 2P/4P – Kit controller, Modbus, HMI-integrated, 2-pipe, 4-pipe, EC fan speed, white (black)
TCPOD WHITE (BLACK) 2P+EH – Kit controller, Modbus, HMI-integrated, 2-pipe+ electrical heater, EC fan speed, white (black)
PAW-FC-907AC/EC – Wired remote controller with touch control
PAW-FC-903AC/EC – Wired remote controller
PAW-FC-RC1 – Advanced wired remote controller

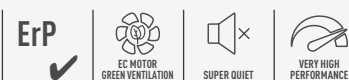

ErP compliant following COMMISSION REGULATION (EU) 2016/2281.



# Storage tanks for heating and DHW

NEW

## Buffer tanks



Model		PAW-BTANK50L-2	PAW-BTANK100L	PAW-BTANKG200L	PAW-BTANKG260L	PAW-BC50FAE	PAW-BC80FAE	PAW-BC100FAE
Water volume	L	48	100	194	252	500	800	1000
Energy losses	W							
<b>Energy efficiency class (from A+ to F)</b>		<b>B</b>	<b>B</b>	<b>B</b>	<b>C</b>	<b>C</b>	<b>C</b>	<b>C</b>
Material		Stainless steel	Stainless steel	Carbon Steel	Carbon Steel	Carbon Steel	Carbon Steel	Carbon Steel
Electric heater	kW	—	—	—	—	Optional PAW-HT9F24AE8	Optional PAW-HT9F24AE8	Optional PAW-HT9F24AE8
Jacket		Included	Included	Included	Included	Included	PAW-JKBC80FAE	PAW-JKBC100FAE
Dimension (Height / Diameter)	mm	636 / 430	1175 / 430	983 / 620	1239 / 620	1725 / 650	1785 / 790	2135 / 790
Net weight	kg	13	22	41	46	85	107	132

\*Automatic air vent and drain cock are included. Built-in pocket sensor (sensor not included). \*\*50 and 100 L Buffer Tanks are produced by OSO. 200 and 260 L Buffer Tanks are produced by Lapesa. 500, 800 and 1000 L Buffer Tanks are produced by Austria Email.

### Accessories

#### PAW-HT9F24AE8

Adjustable 3 phase electric heater D240 mm.  
Selectable output: 9,00 / 7,50 / 6,00 kW. Compatible with  
PAW-TE75H1AEAN, PAW-TE90H1AEAN, PAW-BC50FAE,  
PAW-BC80FAE and PAW-BC100FAE

### Accessories

**PAW-JKBC80FAE** Jacket for 800 L buffer tank (PAW-BC80FAE)

**PAW-JKBC100FAE** Jacket for 1000 L buffer tank (PAW-BC100FAE)

## Combo tanks

The best option to combine with Mono-bloc units. DHW tank with buffer tank. Designed for retrofit applications, the DHW tank with a buffer tank is particularly suitable for fast integration on an existing installation. Easy to install, nice looking, high-efficiency for DHW production and for heating.

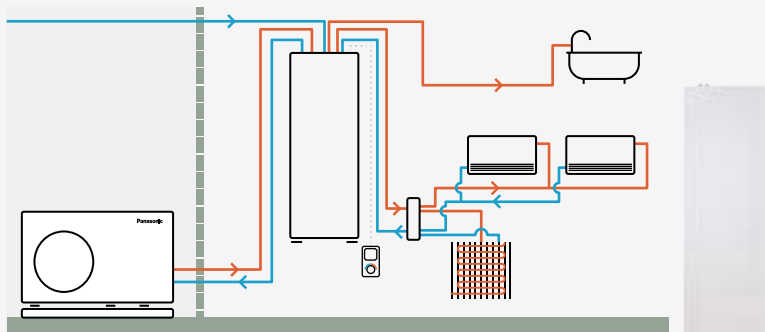

Model		PAW-TD20B8E3-2		PAW-TD23B6E5	
Material		Enamelled		Stainless steel	
Dimension HxWxD	mm	1770 x 640 x 690		1750 x 600 x 646	
Weight (empty)	kg	150		111	
Water volume	L	185 + 80		230 + 60	
Power supply	V, Phase, Hz	230, 1, 50		230, 1, 50	
		<b>Hot water tank</b>	<b>Buffer tank</b>	<b>Hot water tank</b>	<b>Buffer tank</b>
Water volume	L	185	80	230	60
<b>Energy efficiency class (from A+ to F) <sup>1)</sup></b>		<b>B</b>	<b>B</b>	<b>B</b>	<b>A</b>
Max working pressure	MPa (bar)	0,8 (8)	0,6 (6)	1,0 (10)	0,3 (3,0)
Pressure test	MPa (bar)	1,2 (12)	0,9 (9)	1,5 (15)	0,39 (3,9)
Max working temp	°C	90	90	80	80
Connections	mm	Ø22		Ø22, copper	
Material		S 275 JR vitrified		EN 14521	
Insulation	Material, t=mm	PUR, 50		PUR, 50	
Heating coil surface	m <sup>2</sup>	2,1		1,8	
Electric heater	W	3000		2800	
Energy loss at 65 °C <sup>2)</sup>	kWh/24h	1,3		1,25	
Standing loss	W	53		52	
			46		29

1) EU Regulation 812/2013. 2) Tested pursuant to EN 12897:2006. \*Enamelled Combo tank is produced by Lapesa. Stainless steel Combo tank is produced by OSO.

 DHW tanks certified with selected outdoor units. See certifications at: [www.heatpumpkeymark.com](http://www.heatpumpkeymark.com)

**NEW**

**Enamelled DHW tanks**

- Optional 3 way valve accessory
- 20 m temperature sensor cable included
- 2 Years warranty of the inner vessel



Model	PAW-	TA15C1E5	TA20C1E5STD	TA30C1E5STD	TA30C2E5STD	TA40C1E5STD	TE50H1AE	TE75H1AEAN	TE90H1AEAN
Water volume	L	167	200	290	350	380	500	750	900
Maximum water temperature	°C	90	95	95	95	95	95	95	95
Dimension (Height / Diameter)	mm	1297 / 560	1340 / 610	1800 / 610	1835 / 670	1835 / 670	1806 / 760	2000 / 1000 <sup>1)</sup>	2350 / 1000 <sup>1)</sup>
Weight / filled with water	kg	88 / 255	90 / 280	120 / 389	169 / 519	191 / 572	254 / 754	317 / 1067	374 / 1274
Electric heater	kW	—	3,00	3,00	3,00	3,00	Optional PAW-HT6F18AE8	Optional PAW-HT6F18AE8	Optional PAW-HT6F18AE8
Jacket		Included	Included	Included	Included	Included	Included	PAW-JKTE75H1AE	PAW-JKTE90H1AE
Power supply	V	—	230	230	230	230	—	—	—
Material		Enamelled	Enamelled	Enamelled	Enamelled	Enamelled	Enamelled	Enamelled	Enamelled
Vessel protection (anode type)		Magnesium	Magnesium	Magnesium	Magnesium	Magnesium	Magnesium	Electronic	Electronic
Number of coils		1	1	1	2 (solar + heat pump)	1	1	1	1
Exchange surface	m <sup>2</sup>	1,8	1,8	2,6	3,5 / 1,2	3,8	6	6	7,5
Energy loss at 65 °C <sup>2)</sup>	kWh/24h	1,08	1,37	1,61	1,76	1,76	1,90	2,56	2,87
Energy losses	W	45	57	67	73	73	79	107	120
<b>Energy efficiency class (from A+ to F)</b>		<b>B</b>	<b>B</b>	<b>B</b>	<b>B</b>	<b>B</b>	<b>B</b>	<b>C</b>	<b>C</b>

1) Including Jacket. 2) Insulated tested under EN12897. \*Refer to the service manual for further details. \*\*PAW-TA15C1E5 is produced by Lapesa. All other Enamelled tanks are produced by AEmail.

Accessories	
<b>PAW-HT6F18AE8</b>	Adjustable 3 phase electric heater D180 mm. Selectable output: 6,00 / 4,00 / 3,00 kW. Compatible with PAW-TE50H1AE
<b>PAW-HT9F24AE8</b>	Adjustable 3 phase electric heater D240 mm. Selectable output: 9,00 / 7,50 / 6,00 kW. Compatible with PAW-TE75H1AEAN, PAW-TE90H1AEAN, PAW-BC50FAE, PAW-BC80FAE and PAW-BC100FAE

Accessories	
<b>PAW-JKTE75H1AE</b>	Jacket for 750 L DHW tank (PAW-TE75H1AEAN)
<b>PAW-JKTE90H1AE</b>	Jacket for 900 L DHW tank (PAW-TE90H1AEAN)

**Stainless steel DHW tanks**

- Optional 3 way valve accessory
- 20 m temperature sensor cable included
- 2 Years warranty
- No maintenance required



Model		PAW-TD20C1E5-1	PAW-TD30C1E5-1	PAW-TD30C1E5HI-1
Water volume	L	192	284	280
Maximum water temperature	°C	75	75	75
Energy losses	W	42	49	49
<b>Energy efficiency class (from A+ to F)</b>		<b>A</b>	<b>A</b>	<b>A</b>
Material		Stainless steel	Stainless steel	Stainless steel
Electric heater	kW	1,5	1,5	1,5
Dimension (Height / Diameter)	mm	1270 / 595	1750 / 595	1750 / 595
Weight / filled with water	kg	50 / —	61 / —	65 / —
Power supply	V	230	230	230
Exchange surface	m <sup>2</sup>	1,8	1,8	2,35
Energy loss at 65 °C <sup>1)</sup>	kWh/24h	1,01	1,18	1,18

1) Insulated tested under EN12897. \*Stainless steel tanks are produced by OSO.

Accessories for sanitary tanks	
<b>PAW-3WYVLV-HW</b>	3 way valve for DHW tanks
<b>CZ-NV1</b>	3 way valve kit to fit inside the hydrokit. H and J Series
<b>CZ-NV2</b>	3 way valve kit to fit inside the hydrokit. K and L Series

Accessories for sanitary tanks	
<b>CZ-NV3</b>	3 way valve kit to fit inside the hydrokit. M Series
<b>PAW-EANODE2</b>	Impressed current anode for 200 L Stainless steel tanks
<b>PAW-EANODE3</b>	Impressed current anode for 300 L Stainless steel tanks

## Heat recovery ventilation unit

The heat recovery ventilation unit is design not only to provide a good indoor air quality, but it is also designed to recover heat that would otherwise be lost throughout ventilation. These heat recovery ventilation systems are used to assist in the retention of heat.

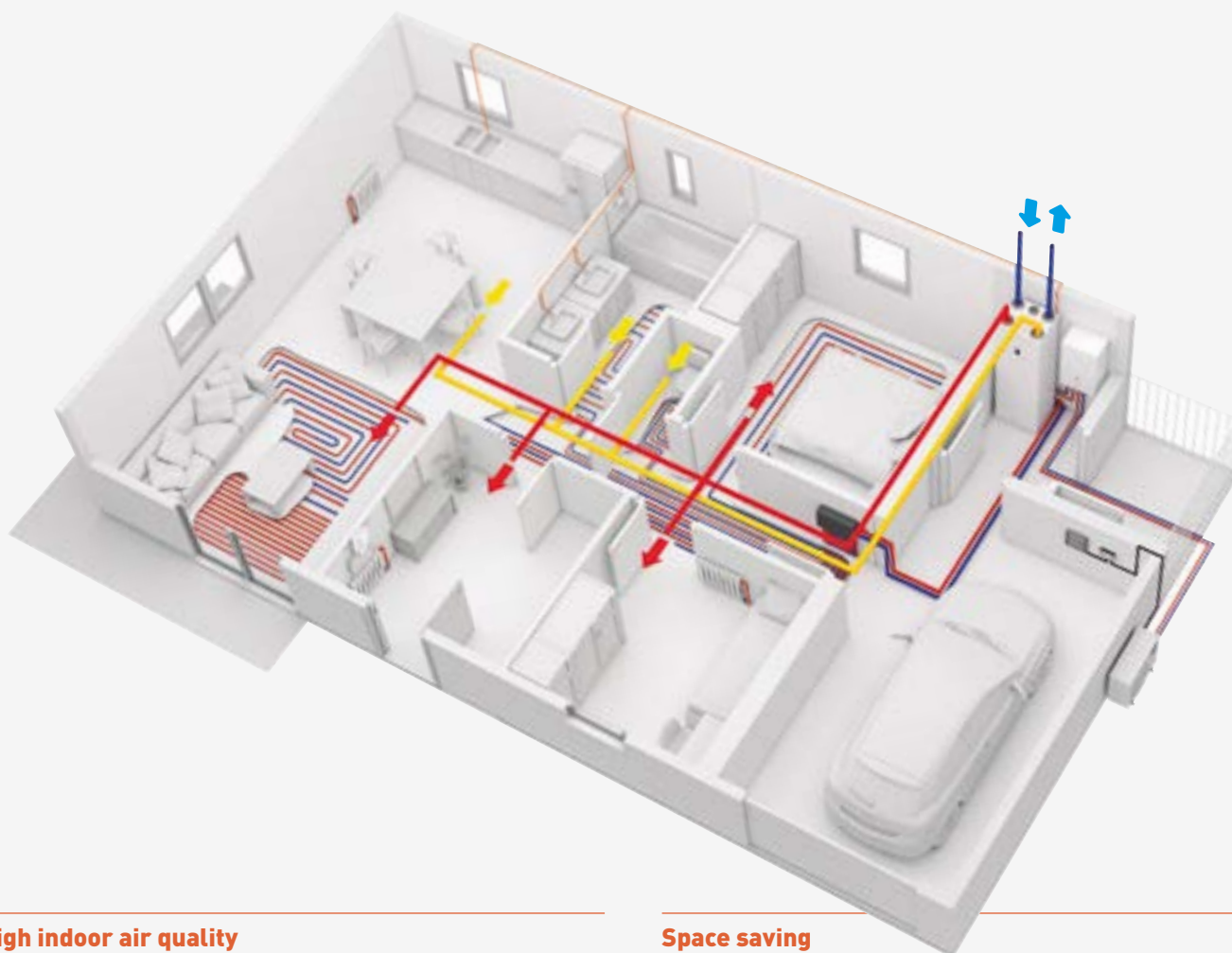

### High indoor air quality

The unit is designed to provide fresh filtered air into the home, while keeping a high thermal comfort.

### Energy saving

Most of the energy from the exhausted air is used to precondition the incoming air, leading to lower heating requirements in the building.

### Space saving

The compact ventilation unit can be installed over the DHW square tank or the Aquarea All in One Compact indoor unit for an space saving solution.

### Better user interface

The Residential ventilation unit and the Aquarea Heat Pumps can be controlled with one single user-friendly controller.

AQUAREA

**Combine the Residential ventilation unit with Panasonic Aquarea for an space saving and highly efficient solution for heating, cooling, ventilation and DHW.**



### Heat Recovery Ventilation + Aquarea All in One Compact.

\*The unit can be mounted on a All in One indoor unit (K, L or M Series) or installed on the wall (PAW-VEN-WBRK is needed).





Heat recovery ventilation unit



Model	PAW-A2W-VENTA-R	PAW-A2W-VENTA-L
Nominal air flow rate	m <sup>3</sup> /h	204 @ 50 Pa
Maximum air flow rate	m <sup>3</sup> /h	292 @ 100 Pa
SPF		1,24 @ 204 m <sup>3</sup> /h
Heat exchanger rotor drive type		Variable speed
Exchanger type		Rotating
Heat recovery efficiency		84%
Power supply	V / Hz	230 / 50 / Single phase
Power consumption	W	176
<b>Energy class, basic unit</b>		<b>A</b>
<b>Energy class, unit with local control on demand</b>		<b>A</b>
Noise level	dB(A)	40
Dimension (HxWxD)	mm	450x598x500
Weight	kg	46
Mounting position		Vertical
Supply side		Right Left
Duct connections	mm	DN125
Filter class, supply air		F7/ePM1 60%
Filter class, extract air		M5/ePM10 50%
Minimum outdoor temperature	°C	-20

\*Heat recovery efficiency according to EN 13141-7. \*\*Heat recovery ventilation unit is produced by Systemair.

Accessories	
<b>PAW-VEN-FLTKIT</b>	Supply and extract filters kit
<b>PAW-VEN-ACCPCB</b>	Optional PCB for additional functions
<b>PAW-VEN-DPL</b>	HRV touch control panel. White frame (cable must be ordered separately)
<b>PAW-VEN-CBLEXT12</b>	Cable with plug for electrical connection between unit and control panel, type CE and CD (12 m)
<b>PAW-VEN-DIVPLG</b>	Twin plugs for installation of several control panels type CD or CE for one unit

Accessories	
<b>PAW-VEN-DPLBOX</b>	HRV touch control panel wall-mounted kit
<b>PAW-VEN-S-CO2RH-W</b>	CO <sub>2</sub> , RH wall-mounted sensor
<b>PAW-VEN-S-CO2-W</b>	CO <sub>2</sub> wall-mounted sensor
<b>PAW-VEN-S-CO2-D</b>	CO <sub>2</sub> duct sensor
<b>PAW-VEN-WBRK</b>	Wall bracket kit for stand-alone installation on the wall
<b>PAW-VEN-HTR06</b>	Electrical duct heater 0,6 kW (includes relay)
<b>PAW-VEN-HTR12</b>	Electrical duct heater 1,2 kW (includes relay)

Main features of the residential ventilation unit

- Designed for areas up to approximately 140 m<sup>2</sup>
- High energy efficiency rotary heat exchanger with EC - technology fans
- Moisture transfer function to minimize condensation in supply air during wintertime
- The built in humidity sensor in extract air can be used for demand control
- Control via touch display and Startup Wizard for easy commissioning

- Modbus communication via RS-485
- Option to control an Aquarea H Series onwards heat pump from PAW-A2W-VENTA control panel Modbus gateway (PAW-AZAW-MBS-M, PAW-AW-MBS-M, CZ-NSMB-C or CZ-NSMB) and PAW-VEN-ACCPCB required

Control user-friendly interface

All settings and features accessible via a control panel, integrated into the front cover. The option for connecting one or more external control panels is available.

- Color touch screen with a user-friendly interface
- MANUAL and AUTO mode or choose preferred settings from the pre-configured user modes

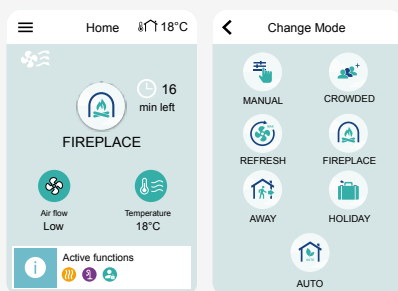

- If Aquarea H and J Series heat pumps are connected with PAW-A2W-VENTA, the heat pump control options appear on the home screen in a separate tab

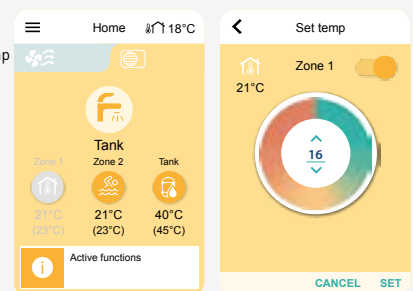

## Aquarea Vent - Counter flow ventilation

Aquarea Vent systems provide a continuous supply of fresh air, ensuring optimal indoor air quality and comfort. Ideal for single-family homes or apartments with low energy requirements, Panasonic's HRV systems combine high-efficiency heat recovery, quiet operation, and advanced air filtration with flexible installation options.



### Vent PRO.

Access the tool via the 'Tools' section in the Panasonic Pro Club ([www.panasonicproclub.com](http://www.panasonicproclub.com)).

From selecting the right ventilation unit to planning the air distribution system and choosing the appropriate components, the Vent PRO guides you through every step to ensure the optimal solution for your project.





**Aquarea Vent - Counter flow ventilation units**



**REFER TO PAGE 120 FOR THE COMPLETE LIST OF FILTERS AND ACCESSORIES FOR AIR DISTRIBUTION AND DIFFUSION SYSTEMS**

			Universal mounting				Horizontal mounting				Vertical mounting			
<b>P-VEN</b>			<b>15XQAZE5</b>	<b>20XQAZE5</b>	<b>30XQAZE5</b>	<b>15XQAHE5</b>	<b>30XQAHE5</b>	<b>35XQAHE5</b>	<b>45XQAHE5</b>	<b>15XQAVE5</b>	<b>30XQAVE5</b>	<b>40XQAVE5</b>	<b>45XQAVE5</b>	
Air flow	Nominal / Max	m <sup>3</sup> /h	91/130	147/210	224/ 320	109/155	210/300	238/340	288/455	112/170	210/300	266/380	315/450	
Static pressure	Nominal / Max	Pa	50/100	50/100	50/100	50/100	50/100	50/100	50/100	50/100	50/100	50/100	50/100	
Recovery efficiency		%	87	85	85	86	85	89	88	86	86	87	86	
Energy class			A	A	A	A	A	A	A	A	A	A	A	
Power supply	Voltage	V	230	230	230	230	230	230	230	230	230	230	230	
	Phase		Single phase	Single phase	Single phase	Single phase	Single phase	Single phase	Single phase	Single phase	Single phase	Single phase	Single phase	
	Frequency	Hz	50	50	50	50	50	50	50	50	50	50	50	
Power consumption	Nominal	W	80	140	180	110	180	350	420	110	180	350	420	
Sound power LWA		dB[A]	48	51	52	49	50	52	56	48	50	51	54	
Dimension	H x W x D	mm	255 x 580 x 580	255 x 580 x 580	255 x 580 x 580	260 x 480 x 800	295 x 600 x 795	290 x 650 x 1150	290 x 1150 x 1150	510 x 430 x 625	590 x 575 x 785	590 x 735 x 785	590 x 785 x 735	
Net weight		kg	19	19	19	25	30	38	40	32	38	42	43	
Filter class			ePM1 80%	ePM1 80%	ePM1 80%	ePM1 80%	ePM1 70%	ePM1 70%	ePM1 70%	ePM1 80%	ePM1 70%	ePM1 70%	ePM1 70%	
Duct connection		mm	160	160	160	160	160	160	160	160	160	160	160	

**HIGH-EFFICIENCY SENSIBLE HEAT RECOVERY**

**HIGHLY EFFICIENT AIR RENEWAL AND FILTRATION, WITH 80% EPM1 FILTERS**

**INTEGRATED AIR QUALITY, HUMIDITY AND TEMPERATURE SENSORS**

**REMOTE CONTROL VIA WI-FI (OPTIONAL)**

**Balanced ventilation**

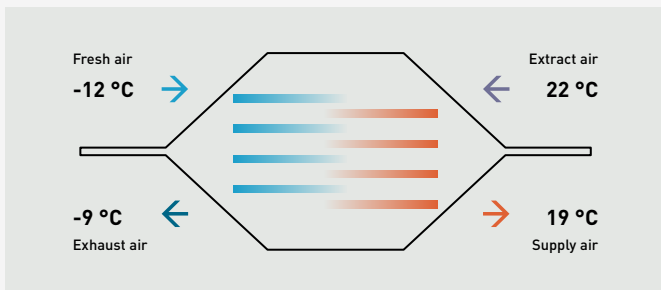

Counter flow ventilation units are equipped with two fans to supply and extract air. A cross-flow heat exchanger recovers the energy contained in the extracted air and transfers it to the supplied air. This significantly reduces the building's energy consumption, while at the same time keeping a good quality of the indoor air.

**Control options (required, to be ordered separately).**

**Wall-mounted control with Modbus.**

PCZ-AHRP0025

**Wall-mounted control with integrated Wi-Fi for remote control via the Aquarea Home App.**

PCZ-AHRP0026

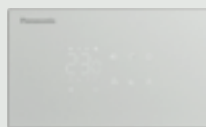

- Integrated VOC - CO<sub>2</sub> air quality sensors
- Integrated humidity sensors
- Integrated temperature sensors
- Unit control and settings: Seasonal modes, temperature and fan speed ventilation settings
- Connectivity: Wi-Fi or Modbus

**Aquarea Home App**

**Download free app.**

Other hardware requirements: Router and Internet (purchase and subscribe separately). Panasonic Cloud Server is designed, operated and managed by Panasonic.

\*The app screen is for illustration purposes only. The actual screen may differ.

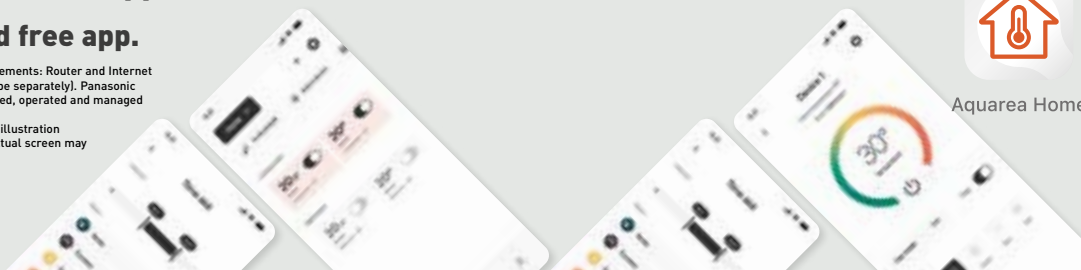

## Aquarea DHW Heat Pumps

Using the natural refrigerant R290, Aquarea DHW Heat Pumps achieve the highest A+ energy efficiency class in their category, significantly reducing energy consumption and CO<sub>2</sub> emissions compared to electric heaters. The range includes wall-mounted and floor-standing models with tank capacities from 100 to 260 litres, designed to meet different household needs.



A+

**HIGH  
PERFORMANCE  
AND A+ ENERGY  
RANK**

**-7°C WIDE  
OPERATION  
RANGE**  
**+43°C**



**SAVES MAINTENANCE  
TIME WITH DRY CHECK  
FOR MAGNESIUM ANODE**



**USER-  
FRIENDLY  
TOUCH  
CONTROL**



Check all our certified heat pumps on:  
[www.heatpumpkeymark.com](http://www.heatpumpkeymark.com)

**Aquarea DHW Heat Pumps**

Type	Wall-mounted			Floor-standing			
	Reference	P-DHW100AE5	P-DHW150AE5	P-DHW200AE5	P-DHW200CAE5	P-DHW260AE5	P-DHW260CAE5
<b>Performance according to EN 16147</b>							
Reference hot water temperature [T <sub>ref</sub> ]	°C	55	55	55	55	55	55
Heating up time [A +14 °C / W 55 °C]	h:m	5:44	8:36	7:24	7:11	9:20	9:37
Heating up time [A +7 °C / W 55 °C]	h:m	6:44	9:48	7:47	7:38	10:24	10:27
Heating up time [A +2 °C / W 55 °C]	h:m	9:53	12:10	11:21	11:14	14:35	14:45
Heating up time in BOOST mode [A +7 °C / W 10-55 °C]	h:m	2:37	4:16	3:43	3:39	4:39	4:55
DHW tank ERP efficiency average / warm / cold	A+ to F	A+/A++/A	A+/A+/A+	A+/A++/A	A+/A++/A	A+/A++/A	A+/A+/A
DHW tank ERP average climate η / COPdHW	η <sub>wh</sub> % / COPdHW	116 / 2,80	122 / 3,00	145 / 3,48	140 / 3,36	146 / 3,52	145 / 3,48
DHW tank ERP warm climate η / COPdHW	η <sub>wh</sub> % / COPdHW	133 / 3,20	137 / 3,40	154 / 3,76	150 / 3,61	155 / 3,78	154 / 3,76
DHW tank ERP cold climate η / COPdHW	η <sub>wh</sub> % / COPdHW	92 / 2,20	109 / 2,70	114 / 2,79	108 / 2,63	115 / 2,81	114 / 2,79
Indoor sound power <sup>1)</sup>	dB(A)	46	46	50	50	50	50
Outdoor sound power <sup>1)</sup>	dB(A)	51	51	56	56	56	56
Load profile		M	L	L	L	XL	XL
Water volume	L	100	142	202	194	260	251
Water volume of mixed water at 40 °C / V40	L	128	173	278	267	359	348
Additional coil exchanger connection		—	—	—	1" M	—	1" M
Additional coil surface	m <sup>2</sup>	—	—	—	1,05	—	1,05
Anticorrosion system	Anode	Magnesium	Magnesium	Magnesium	Magnesium	Magnesium	Magnesium
Anti-legionella cycle		Yes	Yes	Yes	Yes	Yes	Yes
Maximum working pressure - storage tank	Mpa (bar)	0,8 (8)	0,8 (8)	0,8 (8)	0,8 (8)	0,8 (8)	0,8 (8)
Dimension (H x W x D)	mm	1351 x 520 x 541	1682 x 520 x 541	1621 x 705 x 694	1621 x 705 x 694	1911 x 705 x 694	1911 x 705 x 694
Empty weight	kg	56	71	96	110	113	127
Heat pump air intake temperature range	°C	-5 ~ +43	-5 ~ +43	-7 ~ +43	-7 ~ +43	-7 ~ +43	-7 ~ +43
Maximum water temperature / with heater	°C	60 / 70	60 / 70	65 / 75	65 / 75	65 / 75	65 / 75
Refrigerant charge (R290)	kg	0,15	0,15	0,15	0,15	0,15	0,15
Power supply / frequency	V / Hz	230 / 50	230 / 50	230 / 50	230 / 50	230 / 50	230 / 50
Total maximum power consumption	W	1726	1726	1970	1970	1970	1970
Heat pump maximum power consumption	W	226	226	470	470	470	470
Electric heating element power consumption	W	1500	1500	1500	1500	1500	1500
Nominal air flow	m <sup>3</sup> /h	235	235	360	360	360	360
Available external pressure	Pa	71	71	88	88	88	88
Duct diameter	mm	125	125	160	160	160	160

1) According to EN12102.

**Wall mounted version..**

- 100 L and 150 L DHW tank
- Wide operating range from -5 to +43 °C.
- 60 °C hot water only with heat pump



**Floor standing version.**

- 200 L and 260 L DHW tank
- Version with additional coil for operation with other heat sources such as PV panels
- Wide operating range from -7 to +43 °C
- 65 °C hot water only with heat pump



**Space saving design**

Side air ducts for easy installation in rooms as small as 2 metres high.

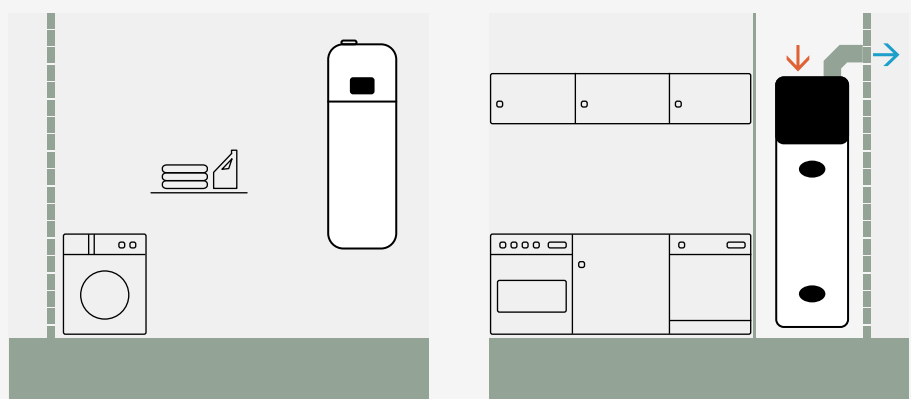

# Accessories and control

## Controls and room thermostats

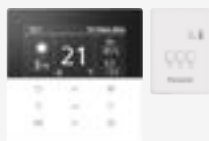

Remote controller with Wi-Fi adapter (required for stand-alone outdoor units). M Series. Includes 10 m extension cable.

CZ-RTW2TAW1C



Optional remote controller for 2 zone control. K and L Series.

CZ-RTW1

Optional remote controller for 2 zone control. M Series.

CZ-RTW2-1

Cover for the remote control compartment of the indoor unit. K Series onwards.

PAW-A2W-COV-KL



Wired LCD room thermostat with weekly timer.

PAW-A2W-RTWIRED



Wireless LCD room thermostat with weekly timer.

PAW-A2W-RTWIRELESS

## Cascade solutions



Cascade manager for Aquarea Heat Pumps. Cascade up to 10 Aquarea Heat Pumps.

PAW-A2W-CMH-3



Aquarea Cascade Edge (manager) for Aquarea Heat Pumps with P-Smart Edge control and monitoring software. Cascade up to 4 units.

PAW-A2W-CME4

Aquarea Cascade Edge (manager) for Aquarea Heat Pumps with P-Smart Edge control and monitoring software. Cascade up to 10 units.

PAW-A2W-CME10

## tado° room control and smart energy management

### tado° Room control sets with Heat Pump Optimizer X



Set of tado° Heat Pump Optimizer X and 1x Smart Radiator Thermostat X.

KIT-TSRTXHP0XE



Set of tado° Heat Pump Optimizer X and 4x tado° Smart Radiator Thermostat X.

KIT-TSRTX4HP0XE



Set of tado° Heat Pump Optimizer X and 1x Smart Thermostat X.

KIT-TSTXHP0XE



Set of tado° Heat Pump Optimizer X and 1x Smart Thermostat X and 2x Smart Radiator Thermostat X.

KIT-TSTXSRTX2HP0XE

### tado° Room control sets with Bridge X



tado° Smart Radiator Thermostat X with Bridge X.

PAW-TSRTXB



tado° Smart Thermostat X with Bridge X.





PAW-TSTXB



Set of 1x Smart Thermostat X, 2x Smart Radiator Thermostat X and 1x Bridge X.

PAW-TSTXSRTX2B

tado° X devices









 <p><b>tado° Heat Pump Optimizer X (with Europlug).</b></p> <p>-----</p> <p>PAW-THPOXE</p>	<p><b>tado° Heat Pump Optimizer X extension cable (10m).</b></p> <p>-----</p> <p>PAW-THPO-CBL</p>	 <p><b>tado° Smart Thermostat X.</b></p> <p>-----</p> <p>PAW-TSTX</p>	<p><b>tado° Wireless Temperature Sensor X.</b></p> <p>-----</p> <p>PAW-TWTSX</p>
 <p><b>tado° Smart Radiator Thermostat X.</b></p> <p>-----</p> <p>PAW-TSRTX</p>	<p><b>4x tado° Smart Radiator Thermostat X.</b></p> <p>-----</p> <p>PAW-TSRTX4</p>	 <p><b>tado° Bridge X.</b></p> <p>-----</p> <p>PAW-TBX</p>	 <p><b>NEW! tado° X Wireless receiver.</b></p> <p>-----</p> <p>PAW-TWRXE</p>

PCBs for additional functions



<p><b>PCB for advanced functions. H and J Series.</b></p> <p>-----</p> <p>CZ-NS4P</p>	<p><b>PCB for advanced functions. K and L Series.</b></p> <p>-----</p> <p>CZ-NS5P</p>	<p><b>PCB for advanced functions. M Series All in One and Bi-bloc.</b></p> <p>-----</p> <p>CZ-NS6P</p>	<p><b>PCB for advanced functions. M Series control module.</b></p> <p>-----</p> <p>CZ-NS7P</p>
---------------------------------------------------------------------------------------	---------------------------------------------------------------------------------------	--------------------------------------------------------------------------------------------------------	------------------------------------------------------------------------------------------------

Connectivity

 <p><b>Optional Wi-Fi or WLAN adapter for Panasonic Comfort Cloud app and Aquarea Service Cloud.</b></p> <p>-----</p> <p>CZ-TAW1B</p> <p><b>10 m extension cable for CZ-TAW1B.</b></p> <p>-----</p> <p>CZ-TAW1-CBL</p>	 <p><b>Modbus RTU PCB for Aquarea M Series. For installation inside control module or Bi-bloc and All in One using installation kit CZ-NSMB-MTPL.</b></p> <p>-----</p> <p>CZ-NSMB</p>		<p><b>NEW! Modbus PCB installation kit for Bi-bloc and All in One.</b></p> <p>-----</p> <p>CZ-NSMB-MTPL</p>	<p><b>NEW! Panasonic Modbus RTU gateway with plastic case, compatible with all Aquarea Series.</b></p> <p>-----</p> <p>CZ-NSMB-C</p>	 <p><b>Modbus RTU gateway. 12 V DC power supply, compatible with Aquarea H Series onwards.</b></p> <p>-----</p> <p>PAW-AZAW-MBS-M</p>
 <p><b>Aquarea Home Network Hub for remote control via the Aquarea Home App.</b></p> <p>-----</p> <p>PCZ-ESW737</p>	 <p><b>External meter gateway for K Series onwards.</b></p> <p>-----</p> <p>PAW-A2W-EXTMETER</p>	 <p><b>NEW! DIN rail-mounted Modbus RTU gateway. Powered via CN-CNT, compatible with Aquarea H Series onwards.</b></p> <p>-----</p> <p>PAW-AW-MBS-M</p>	 <p><b>KNX interface for H Series onwards (Airzone).</b></p> <p>-----</p> <p>PAW-AZAW-KNX-1</p>	 <p><b>KNX interface for H Series onwards (Intesis).</b></p> <p>-----</p> <p>PAW-AW-KNX-H</p>	 <p><b>NEW! EEBUS gateway for H Series onwards.</b></p> <p>-----</p> <p>PAW-AZAW-EEBUS-1</p>

Sensors for Aquarea H Series onwards

 <p><b>Outdoor ambient sensor.</b></p> <p>-----</p> <p>PAW-A2W-TS0D</p>	 <p><b>Zone room sensor.</b></p> <p>-----</p> <p>PAW-A2W-TSRT</p>	 <p><b>Zone water sensor.</b></p> <p>-----</p> <p>PAW-A2W-TSHC</p>	 <p><b>Solar sensor.</b></p> <p>-----</p> <p>PAW-A2W-TSS0</p>	 <p><b>Buffer tank sensor (for H and J Series, PAW-A2W-TSHC required if optional PCB is used.)</b></p> <p>-----</p> <p>PAW-A2W-TSBU</p>	<p><b>In-line heater sensor for the control module M Series.</b></p> <p>-----</p> <p>PAW-A2W-TSBH</p>
----------------------------------------------------------------------------------------------------------------------------------------------------------	----------------------------------------------------------------------------------------------------------------------------------------------------	-----------------------------------------------------------------------------------------------------------------------------------------------------	-------------------------------------------------------------------------------------------------------------------------------------------------	----------------------------------------------------------------------------------------------------------------------------------------------------------------------------------------------------------------------------	-------------------------------------------------------------------------------------------------------

All in One indoor unit accessories

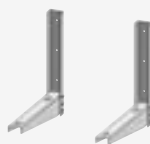





**NEW!** Wall bracket to mount the All in One 120 L on the wall.

\*Check availability.

-----

CZ-NW1

Outdoor unit accessories

 <p><b>Base pan heater for Bi-bloc 3 and 5 kW (except L Series) and K Series 7 and 9 kW (1 fan model).</b></p> <p>-----</p> <p>CZ-NE2P</p>	<p><b>Base pan heater. H and J Series and K Series 9 kW (2 fans model), 12 and 16 kW.</b></p> <p>-----</p> <p>CZ-NE3P</p>	 <p><b>Outdoor base ground support for noise and vibration absorption.</b> Dimension (HxWxD): 600x95x130 mm Safe working load: 500 kg</p> <p>-----</p> <p>PAW-GRDBSE20</p>	<p><b>NEW!</b> Heat pump foundation made from 100% recycled materials</p> <p>-----</p> <p>PAW-RPB1AE</p>
<p><b>Base pan heater. L Series 5, 7 and 9 kW and M Series.</b></p> <p>-----</p> <p>CZ-NE4P</p>	<p><b>Base pan heater. M Series 20, 25, 30 kW.</b></p> <p>-----</p> <p>CZ-NE5P</p>	 <p><b>Black ground stand for outdoor unit with 940 mm wide condenser water tray.</b></p> <p>-----</p> <p>PAW-GRDSTD940</p>	 <p><b>Black ground stand for outdoor unit with 1100 mm wide condenser water tray.</b></p> <p>-----</p> <p>PAW-GRDSTD1100</p>
		 <p><b>Electric heater foil for the ground stand with 940 mm wide condenser water tray.</b></p> <p>-----</p> <p>PAW-GRDSTDHTR940</p>	<p><b>Electric heater foil for the ground stand with 1100 mm wide condenser water tray.</b></p> <p>-----</p> <p>PAW-GRDSTDHTR1100</p>

Hydraulic accessories

 <p><b>3 way valve kit to fit inside the hydrokit. H and J Series.</b></p> <p>-----</p> <p>CZ-NV1</p>	<p><b>3 way valve kit to fit inside the hydrokit. K and L Series.</b></p> <p>-----</p> <p>CZ-NV2</p>	<p><b>3 way valve kit to fit inside the hydrokit. M Series.</b></p> <p>-----</p> <p>CZ-NV3</p>	 <p><b>NEW!</b> G1" 3 way ball valve with actuator for 3-16 kW heat pumps.</p> <p>-----</p> <p>PAW-3WYVLV20-ES</p>	<p><b>NEW!</b> G1 1/2" 3 way valve with actuator for 20-30 kW heat pumps.</p> <p>-----</p> <p>PAW-3WYVLV32-ES</p>
------------------------------------------------------------------------------------------------------------------------------------------------------------------------------------------	------------------------------------------------------------------------------------------------------	------------------------------------------------------------------------------------------------	---------------------------------------------------------------------------------------------------------------------------------------------------------------------------------------------------------	-------------------------------------------------------------------------------------------------------------------

 <p><b>3 way valve for DHW tanks.</b></p> <p>----- PAW-3WVVLV-HW</p>	 <p><b>1 antifreeze valve 1".</b> It is required to order 2 valves per system. For 9, 12 and 16 kW.</p> <p>----- PAW-A2W-AFVLV-1</p>	 <p><b>1 antifreeze valve 1 1/2".</b> It is required to order 2 valves per system. For 20, 25 and 30 kW.</p> <p>----- PAW-A2W-AFVLV-112</p>	<p><b>NEW! Double circulation unit with mixing function (one direct circuit + one mixing circuit).</b></p> <p>----- PAW-A2W-DCUM1</p>	 <p><b>Optional magnet for the water filter in H Series models.</b></p> <p>----- PAW-A2W-MGTFILTER</p>
-----------------------------------------------------------------------------------------------------------------------------------------------------------	-------------------------------------------------------------------------------------------------------------------------------------------------------------------------------------------------------------------------------	--------------------------------------------------------------------------------------------------------------------------------------------------------------------------------------------------------------------------------------	-------------------------------------------------------------------------------------------------------------------------------------------	-----------------------------------------------------------------------------------------------------------------------------------------------------------------------------------------------

**Buffer and DHW tanks accessories**







<p><b>NEW! Adjustable 3 phase electric heater D180 mm. Selectable output: 6,00 / 4,00 / 3,00 kW. Compatible with PAW-TE50H1AE.</b></p> <p>----- PAW-HT6F18AE8</p>	<p><b>NEW! Adjustable 3 phase electric heater D240 mm. Selectable output: 9,00 / 7,50 / 6,00 kW. Compatible with PAW-TE75H1AEAN, PAW-TE90H1AEAN, PAW-BC50FAE, PAW-BC80FAE and PAW-BC100FAE.</b></p> <p>----- PAW-HT9F24AE8</p>
-----------------------------------------------------------------------------------------------------------------------------------------------------------------------	------------------------------------------------------------------------------------------------------------------------------------------------------------------------------------------------------------------------------------

<p><b>NEW! Jacket for 800 L buffer tank (PAW-BC80FAE).</b></p> <p>----- PAW-JKBC80FAE</p>	<p><b>NEW! Jacket for 1000 L buffer tank (PAW-BC100FAE).</b></p> <p>----- PAW-JKBC100FAE</p>	<p><b>NEW! Jacket for 750 L DHW tank (PAW-TE75H1AEAN).</b></p> <p>----- PAW-JKTE75H1AE</p>	<p><b>NEW! Jacket for 900 L DHW tank (PAW-TE90H1AEAN).</b></p> <p>----- PAW-JKTE90H1AE</p>
-----------------------------------------------------------------------------------------------	--------------------------------------------------------------------------------------------------	------------------------------------------------------------------------------------------------	------------------------------------------------------------------------------------------------

**Aquarea DHW Heat Pumps accessories**

<p><b>NEW! Stand for wall-mounted models (required for installation in non-load-bearing walls).</b></p> <p>----- PAW-DHW-STAND-1</p>	<p><b>NEW! Accessory kit for external connection (PV or water pump for circulation).</b></p> <p>----- PAW-DHWSOLAR-KIT</p>
------------------------------------------------------------------------------------------------------------------------------------------	--------------------------------------------------------------------------------------------------------------------------------



**EcoFlex accessories**

 <p><b>CONEX wired remote controller (non-wireless), white.</b></p> <p>----- CZ-RTC6W</p>	 <p><b>CONEX wired remote controller with Bluetooth®, white.</b></p> <p>----- CZ-RTC6WBL</p>	 <p><b>CONEX wired remote controller with Wi-Fi and Bluetooth®, white.</b></p> <p>----- CZ-RTC6WBLW2</p>	 <p><b>CONEX wired remote controller (non-wireless), black.</b></p> <p>----- CZ-RTC6</p>	 <p><b>CONEX wired remote controller with Bluetooth®, black.</b></p> <p>----- CZ-RTC6BL</p>	 <p><b>CONEX wired remote controller with Wi-Fi and Bluetooth®, black.</b></p> <p>----- CZ-RTC6BLW2</p>
----------------------------------------------------------------------------------------------------------------------------------------------------------------------------------	-------------------------------------------------------------------------------------------------------------------------------------------------------------------------------------	-------------------------------------------------------------------------------------------------------------------------------------------------------------------------------------------------	---------------------------------------------------------------------------------------------------------------------------------------------------------------------------------	--------------------------------------------------------------------------------------------------------------------------------------------------------------------------------------	--------------------------------------------------------------------------------------------------------------------------------------------------------------------------------------------------

 <p><b>Wired remote controller for wall-mounted.</b></p> <p>----- CZ-RD517C</p>	 <p><b>Infrared remote controller Sky Remote. 2 m cable length of infrared receiver for hide-away.</b></p> <p>----- CZ-RL511D</p>	 <p><b>Reduces the connection size on the indoor unit from 1/2" to 3/8".</b></p> <p>----- CZ-MA1PA</p>	 <p><b>Increases the connection size on the outdoor unit from 3/8" to 1/2".</b></p> <p>----- CZ-MA2PA</p>	 <p><b>Reduces the connection size on the indoor unit from 5/8" to 1/2".</b></p> <p>----- CZ-MA3PA</p>
------------------------------------------------------------------------------------------------------------------------------------------------------------------------	--------------------------------------------------------------------------------------------------------------------------------------------------------------------------------------------------------------------------	-----------------------------------------------------------------------------------------------------------------------------------------------------------------------------------------------	----------------------------------------------------------------------------------------------------------------------------------------------------------------------------------------------------	-------------------------------------------------------------------------------------------------------------------------------------------------------------------------------------------------

**Aquarea Air Smart fan coil – Floor standing accessories**

**Control accessories**

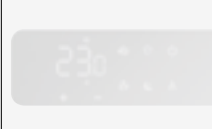
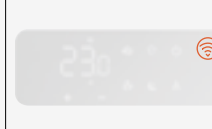
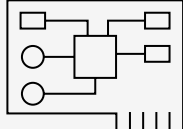
 <p><b>Wall-mounted control with Modbus for Aquarea Air Smart fan coils.</b></p> <p>----- PCZ-EEB749</p>	 <p><b>Wall-mounted control with integrated Wi-Fi for Aquarea Air Smart fan coils.</b></p> <p>----- PCZ-EFB749</p>	 <p><b>Wall-mounted control PCB for Aquarea Air Smart fan coil – Floor standing.</b></p> <p>----- PCZ-ESE845</p>	 <p><b>On-board display with Modbus for Aquarea Air Smart fan coil – Floor standing.</b></p> <p>----- PCZ-ECA844</p>	 <p><b>On-board display with integrated Wi-Fi for Aquarea Air Smart fan coil – Floor standing.</b></p> <p>----- PCZ-EWA844</p>	 <p><b>PCB for analog control (0-10V) for Aquarea Air Smart fan coil – Floor standing.</b></p> <p>----- PCZ-B10842</p>
-----------------------------------------------------------------------------------------------------------------------------------------------------------------------------------------------	---------------------------------------------------------------------------------------------------------------------------------------------------------------------------------------------------------	-------------------------------------------------------------------------------------------------------------------------------------------------------------------------------------------------------	------------------------------------------------------------------------------------------------------------------------------------------------------------------------------------------------------------	-----------------------------------------------------------------------------------------------------------------------------------------------------------------------------------------------------------------------	---------------------------------------------------------------------------------------------------------------------------------------------------------------------------------------------------------------

**Hydraulic accessories**

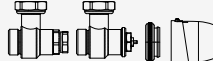
 <p><b>3 way valve with motor for Aquarea Air Smart fan coil – Floor standing.</b></p> <p>----- PCZ-V30720</p>	 <p><b>2 way valve with motor for Aquarea Air Smart fan coil – Floor standing, wall-mounted 40 and ducted.</b></p> <p>----- PCZ-V20139</p>
-----------------------------------------------------------------------------------------------------------------------------------------------------------------------------------------------------	-----------------------------------------------------------------------------------------------------------------------------------------------------------------------------------------------------------------------------------



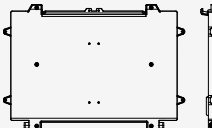
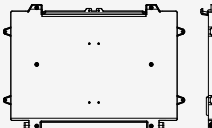
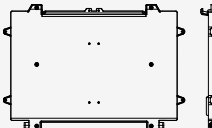
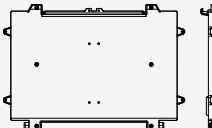
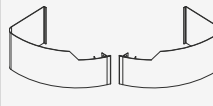
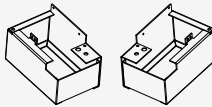

**Installation accessories**

 <p><b>Condensate drip tray for horizontal installation. For P-FAL10.</b></p> <p>----- PCZ-GB0520</p>	 <p><b>Condensate drip tray for horizontal installation. For P-FAL20.</b></p> <p>----- PCZ-GB0521</p>	 <p><b>Condensate drip tray for horizontal installation. For P-FAL30.</b></p> <p>----- PCZ-GB0522</p>	 <p><b>Condensate drip tray for horizontal installation. For P-FAL35.</b></p> <p>----- PCZ-GB0523</p>	 <p><b>Set of 2 legs to protect water pipes for Aquarea Air Smart fan coil – Floor standing.</b></p> <p>----- PCZ-LC0158</p>	 <p><b>Set of 2 legs to anchor the Aquarea Air Smart fan coil – Floor standing to the floor.</b></p> <p>----- PCZ-LC0606</p>
<p><b>Condensate drip tray for horizontal installation. For P-FAL40.</b></p> <p>----- PCZ-GB0524</p>					





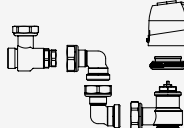
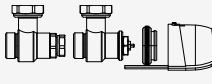

**Aquarea Air Smart fan coil wall-mounted accessories**



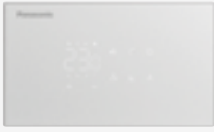
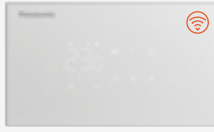
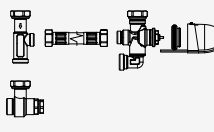
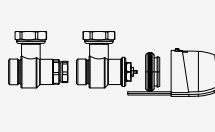
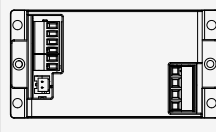

**Control accessories**

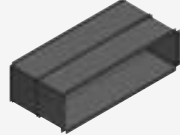
**Hydraulic accessories**

 <p><b>Wall-mounted control with Modbus for Aquarea Air Smart fan coils.</b></p> <p>----- PCZ-EEB749</p>	 <p><b>Wall-mounted control with integrated Wi-Fi for Aquarea Air Smart fan coils.</b></p> <p>----- PCZ-EFB749</p>	 <p><b>3 way valve with motor for Aquarea Air wall-mounted 10, 15 and 20.</b></p> <p>----- PCZ-V30688</p>	 <p><b>3 way valve with motor for Aquarea Air wall-mounted 40.</b></p> <p>----- PCZ-V30718</p>	 <p><b>2 way valve with motor for Aquarea Air wall-mounted 10, 15 and 20.</b></p> <p>----- PCZ-V20687</p>	 <p><b>2 way valve with motor for Aquarea Air Smart fan coil – Floor standing, wall-mounted 40 and ducted.</b></p> <p>----- PCZ-V20139</p>
-------------------------------------------------------------------------------------------------------------------------------------------------------------------------------------------------	-----------------------------------------------------------------------------------------------------------------------------------------------------------------------------------------------------------	--------------------------------------------------------------------------------------------------------------------------------------------------------------------------------------------------	---------------------------------------------------------------------------------------------------------------------------------------------------------------------------------------	----------------------------------------------------------------------------------------------------------------------------------------------------------------------------------------------------	-------------------------------------------------------------------------------------------------------------------------------------------------------------------------------------------------------------------------------------

Aquarea Air Smart fan coil – Ducted thin accessories

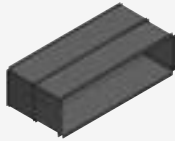
Control accessories			Hydraulic accessories						
 <p>Wall-mounted control with Modbus for Aquarea Air Smart fan coils.</p> <p>-----</p> <p>PCZ-EEB749</p>		 <p>Wall-mounted control with integrated Wi-Fi for Aquarea Air Smart fan coils.</p> <p>-----</p> <p>PCZ-EFB749</p>		 <p>3 way valve with motor for Aquarea Air Smart fan coil – Ducted.</p> <p>-----</p> <p>PCZ-V30361</p>		 <p>2 way valve with motor for Aquarea Air Smart fan coil – Floor standing, wall-mounted 40 and ducted.</p> <p>-----</p> <p>PCZ-V20139</p>		 <p>PCB for underfloor heating valve control. Requires PCZ-EEB749 or PCZ-EFB749.</p> <p>-----</p> <p>PCZ-EG1028</p>	
<p><b>Replacement recirculation filter kit</b></p>	<p><b>Delivery plates</b></p>	<p><b>Return plenum</b></p>	<p><b>90° shooting plenum</b></p>	<p><b>Telescopic kit for rear or directly coupled suction. 153 mm - 270 mm</b></p>	<p><b>Grille for telescopic kit for rear intake</b></p>				
 <p>For P-FSN20 and P-FTN15.</p> <p>-----</p> <p>PCZ-AHRD0491</p>	 <p>With 2 circular inlets DN 160 mm. For P-FTN15.</p> <p>-----</p> <p>PCZ-AHRD0561</p>	 <p>With 2 circular inlets DN 160 mm. For P-FTN15.</p> <p>-----</p> <p>PCZ-AHRD0566</p>	 <p>For P-FTN15.</p> <p>-----</p> <p>PCZ-AHRD0576</p>	 <p>For P-FTN15.</p> <p>-----</p> <p>PCZ-AHRD0581</p>	 <p>For P-FTN15.</p> <p>-----</p> <p>PCZ-AHRD0586</p>				
<p>For P-FSN25, P-FTN20, P-FSQ30 and P-FTQ30.</p> <p>-----</p> <p>PCZ-AHRD0492</p>	<p>With 3 circular inlets DN 160 mm. For P-FTN20.</p> <p>-----</p> <p>PCZ-AHRD0562</p>	<p>With 3 circular inlets DN 160 mm. For P-FTN20.</p> <p>-----</p> <p>PCZ-AHRD0567</p>	<p>For P-FTN20 and P-FTQ30.</p> <p>-----</p> <p>PCZ-AHRD0577</p>	<p>For P-FTN20.</p> <p>-----</p> <p>PCZ-AHRD0582</p>	<p>For P-FTN20.</p> <p>-----</p> <p>PCZ-AHRD0587</p>				
<p>For P-FSN35, P-FTN25, P-FSQ45 and P-FTQ45.</p> <p>-----</p> <p>PCZ-AHRD0493</p>	<p>With 4 circular inlets DN 160 mm. For P-FTN25.</p> <p>-----</p> <p>PCZ-AHRD0563</p>	<p>With 4 circular inlets DN 160 mm. For P-FTN25.</p> <p>-----</p> <p>PCZ-AHRD0568</p>	<p>For P-FTN25 and P-FTQ45.</p> <p>-----</p> <p>PCZ-AHRD0578</p>	<p>For P-FTN25.</p> <p>-----</p> <p>PCZ-AHRD0583</p>	<p>For P-FTN25.</p> <p>-----</p> <p>PCZ-AHRD0588</p>				
<p>For P-FSN45, P-FTN35, P-FSQ60 and P-FTQ60.</p> <p>-----</p> <p>PCZ-AHRD0494</p>	<p>With 6 circular inlets DN 160 mm. For P-FTN35.</p> <p>-----</p> <p>PCZ-AHRD0564</p>	<p>With 6 circular inlets DN 160 mm. For P-FTN35.</p> <p>-----</p> <p>PCZ-AHRD0569</p>	<p>For P-FTN35 and P-FTQ60.</p> <p>-----</p> <p>PCZ-AHRD0579</p>	<p>For P-FTN35.</p> <p>-----</p> <p>PCZ-AHRD0584</p>	<p>For P-FTN35.</p> <p>-----</p> <p>PCZ-AHRD0589</p>				
<p>For P-FSN55, P-FTN45, P-FSQ75 and P-FTQ65.</p> <p>-----</p> <p>PCZ-AHRD0495</p>	<p>With 7 circular inlets DN 160 mm. For P-FTN45.</p> <p>-----</p> <p>PCZ-AHRD0565</p>	<p>With 7 circular inlets DN 160 mm. For P-FTN45.</p> <p>-----</p> <p>PCZ-AHRD0570</p>	<p>For P-FTN45 and P-FTQ65.</p> <p>-----</p> <p>PCZ-AHRD0580</p>	<p>For P-FTN45.</p> <p>-----</p> <p>PCZ-AHRD0585</p>	<p>For P-FTN45.</p> <p>-----</p> <p>PCZ-AHRD0590</p>				





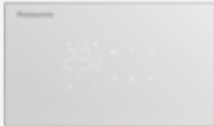
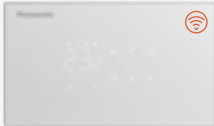
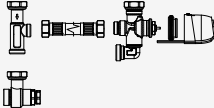
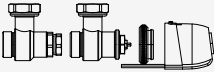
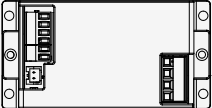



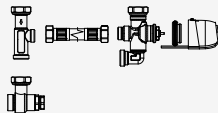
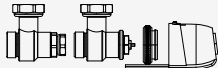

<p><b>Plenum kit for external air connection with damper for room recirculation</b></p>	<p><b>Ducting plate plenum kit for outdoor air connection with damper</b></p>	<p><b>90° plenum for outdoor air kit with damper</b></p>	<p><b>Telescopic kit. For plenum for outdoor air kit with damper</b></p>	<p><b>Grille for telescopic kit. For plenum for outdoor air kit with damper</b></p>
 <p><b>For P-FTN15.</b> ----- PCZ-AHRD0571</p> <p><b>For P-FTN20 and P-FTQ30.</b> ----- PCZ-AHRD0572</p> <p><b>For P-FTN25 and P-FTQ45.</b> ----- PCZ-AHRD0573</p> <p><b>For P-FTN35 and P-FTQ60.</b> ----- PCZ-AHRD0574</p> <p><b>For P-FTN45 and P-FTQ65.</b> ----- PCZ-AHRD0575</p>	 <p><b>For P-FTN15.</b> ----- PCZ-AHRD0611</p> <p><b>For P-FTN20 and P-FTQ30.</b> ----- PCZ-AHRD0612</p> <p><b>For P-FTN25 and P-FTQ45.</b> ----- PCZ-AHRD0613</p> <p><b>For P-FTN35 and P-FTQ60.</b> ----- PCZ-AHRD0614</p> <p><b>For P-FTN45 and P-FTQ65.</b> ----- PCZ-AHRD0615</p>	 <p><b>For P-FTN15.</b> ----- PCZ-AHRD0616</p> <p><b>For P-FTN20 and P-FTQ30.</b> ----- PCZ-AHRD0617</p> <p><b>For P-FTN25 and P-FTQ45.</b> ----- PCZ-AHRD0618</p> <p><b>For P-FTN35 and P-FTQ60.</b> ----- PCZ-AHRD0619</p> <p><b>For P-FTN45 and P-FTQ65.</b> ----- PCZ-AHRD0620</p>	 <p><b>For P-FTN15.</b> ----- PCZ-AHRD0621</p> <p><b>For P-FTN20 and P-FTQ30.</b> ----- PCZ-AHRD0622</p> <p><b>For P-FTN25 and P-FTQ45.</b> ----- PCZ-AHRD0623</p> <p><b>For P-FTN35 and P-FTQ60.</b> ----- PCZ-AHRD0624</p> <p><b>For P-FTN45 and P-FTQ65.</b> ----- PCZ-AHRD0625</p>	 <p><b>For P-FTN15.</b> ----- PCZ-AHRD0626</p> <p><b>For P-FTN20 and P-FTQ30.</b> ----- PCZ-AHRD0627</p> <p><b>For P-FTN25 and P-FTQ45.</b> ----- PCZ-AHRD0628</p> <p><b>For P-FTN35 and P-FTQ60.</b> ----- PCZ-AHRD0629</p> <p><b>For P-FTN45 and P-FTQ65.</b> ----- PCZ-AHRD0630</p>

**Aquarea Air Smart fan coil – Ducted accessories**

Control accessories		Hydraulic accessories		
 <p><b>Wall-mounted control with Modbus for Aquarea Air Smart fan coils.</b></p> <p>----- PCZ-EEB749</p>	 <p><b>Wall-mounted control with integrated Wi-Fi for Aquarea Air Smart fan coils.</b></p> <p>----- PCZ-EFB749</p>	 <p><b>3 way valve with motor for Aquarea Air Smart fan coil – Ducted.</b></p> <p>----- PCZ-V30361</p>	 <p><b>2 way valve with motor for Aquarea Air Smart fan coil – Floor standing, wall-mounted 40 and ducted.</b></p> <p>----- PCZ-V20139</p>	 <p><b>PCB for underfloor heating valve control. Requires PCZ-EEB749 or PCZ-EFB749.</b></p> <p>----- PCZ-EG1028</p>

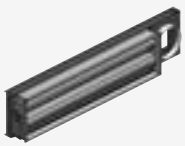
Replacement recirculation filter kit	Delivery plates	Return plenum	90° shooting plenum	Telescopic kit for rear or directly coupled suction. 153 mm - 270 mm	Grille for telescopic kit for rear intake
 <p><b>For P-FSN20 and P-FTN15.</b> ----- PCZ-AHRD0491</p> <p><b>For P-FSN25, P-FTN20, P-FSQ30 and P-FTQ30.</b> ----- PCZ-AHRD0492</p> <p><b>For P-FSN35, P-FTN25, P-FSQ45 and P-FTQ45.</b> ----- PCZ-AHRD0493</p> <p><b>For P-FSN45, P-FTN35, P-FSQ60 and P-FTQ60.</b> ----- PCZ-AHRD0494</p> <p><b>For P-FSN55, P-FTN45, P-FSQ75 and P-FTQ65.</b> ----- PCZ-AHRD0495</p>	 <p><b>With 2 circular inlets DN 160 mm. For P-FSN20.</b> ----- PCZ-AHRD0431</p> <p><b>With 3 circular inlets DN 160 mm. For P-FSN25.</b> ----- PCZ-AHRD0432</p> <p><b>With 4 circular inlets DN 160 mm. For P-FSN35.</b> ----- PCZ-AHRD0433</p> <p><b>With 6 circular inlets DN 160 mm. For P-FSN45.</b> ----- PCZ-AHRD0434</p> <p><b>With 7 circular inlets DN 160 mm. For P-FSN55.</b> ----- PCZ-AHRD0435</p>	 <p><b>With 2 circular inlets DN 160 mm. For P-FSN20.</b> ----- PCZ-AHRD0461</p> <p><b>With 3 circular inlets DN 160 mm. For P-FSN25.</b> ----- PCZ-AHRD0462</p> <p><b>With 4 circular inlets DN 160 mm. For P-FSN35.</b> ----- PCZ-AHRD0463</p> <p><b>With 6 circular inlets DN 160 mm. For P-FSN45.</b> ----- PCZ-AHRD0464</p> <p><b>With 7 circular inlets DN 160 mm. For P-FSN55.</b> ----- PCZ-AHRD0465</p>	 <p><b>For P-FSN20.</b> ----- PCZ-AHRD0521</p> <p><b>For P-FSN25 and P-FSQ30.</b> ----- PCZ-AHRD0522</p> <p><b>For P-FSN35 and P-FSQ45.</b> ----- PCZ-AHRD0523</p> <p><b>For P-FSN45 and P-FSQ60.</b> ----- PCZ-AHRD0524</p> <p><b>For P-FSN55 and P-FSQ75.</b> ----- PCZ-AHRD0525</p>	 <p><b>For P-FSN20.</b> ----- PCZ-AHRD0531</p> <p><b>For P-FSN25.</b> ----- PCZ-AHRD0532</p> <p><b>For P-FSN35.</b> ----- PCZ-AHRD0533</p> <p><b>For P-FSN45.</b> ----- PCZ-AHRD0534</p> <p><b>For P-FSN55.</b> ----- PCZ-AHRD0535</p>	 <p><b>For P-FSN20.</b> ----- PCZ-AHRD0541</p> <p><b>For P-FSN25.</b> ----- PCZ-AHRD0542</p> <p><b>For P-FSN35.</b> ----- PCZ-AHRD0543</p> <p><b>For P-FSN45.</b> ----- PCZ-AHRD0544</p> <p><b>For P-FSN55.</b> ----- PCZ-AHRD0545</p>
<p><b>Plenum kit for external air connection with damper for room recirculation</b></p>	<p><b>Ducting plate plenum kit for outdoor air connection with damper</b></p>		<p><b>90° plenum for outdoor air kit with damper</b></p>	<p><b>Telescopic kit. For plenum for outdoor air kit with damper</b></p>	<p><b>Grille for telescopic kit. For plenum for outdoor air kit with damper</b></p>
 <p><b>For P-FSN20.</b> ----- PCZ-AHRD0639</p> <p><b>For P-FSN25 and P-FSQ30.</b> ----- PCZ-AHRD0640</p> <p><b>For P-FSN35 and P-FSQ45.</b> ----- PCZ-AHRD0641</p> <p><b>For P-FSN45 and P-FSQ60.</b> ----- PCZ-AHRD0642</p> <p><b>For P-FSN55 and P-FSQ75.</b> ----- PCZ-AHRD0643</p>	 <p><b>For P-FSN20.</b> ----- PCZ-AHRD0651</p> <p><b>For P-FSN25 and P-FSQ30.</b> ----- PCZ-AHRD0652</p> <p><b>For P-FSN35 and P-FSQ45.</b> ----- PCZ-AHRD0653</p> <p><b>For P-FSN45 and P-FSQ60.</b> ----- PCZ-AHRD0654</p> <p><b>For P-FSN55 and P-FSQ75.</b> ----- PCZ-AHRD0655</p>		 <p><b>For P-FSN20.</b> ----- PCZ-AHRD0656</p> <p><b>For P-FSN25 and P-FSQ30.</b> ----- PCZ-AHRD0657</p> <p><b>For P-FSN35 and P-FSQ45.</b> ----- PCZ-AHRD0658</p> <p><b>For P-FSN45 and P-FSQ60.</b> ----- PCZ-AHRD0659</p> <p><b>For P-FSN55 and P-FSQ75.</b> ----- PCZ-AHRD0660</p>	 <p><b>For P-FSN20.</b> ----- PCZ-AHRD0661</p> <p><b>For P-FSN25 and P-FSQ30.</b> ----- PCZ-AHRD0662</p> <p><b>For P-FSN35 and P-FSQ45.</b> ----- PCZ-AHRD0663</p> <p><b>For P-FSN45 and P-FSQ60.</b> ----- PCZ-AHRD0664</p> <p><b>For P-FSN55 and P-FSQ75.</b> ----- PCZ-AHRD0665</p>	 <p><b>For P-FSN20.</b> ----- PCZ-AHRD0666</p> <p><b>For P-FSN25 and P-FSQ30.</b> ----- PCZ-AHRD0667</p> <p><b>For P-FSN35 and P-FSQ45.</b> ----- PCZ-AHRD0668</p> <p><b>For P-FSN45 and P-FSQ60.</b> ----- PCZ-AHRD0669</p> <p><b>For P-FSN55 and P-FSQ75.</b> ----- PCZ-AHRD0670</p>

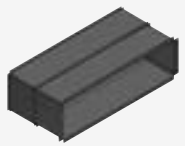











Aquarea Air Smart fan coil – Ducted multi zone thin accessories

Control accessories		Hydraulic accessories			
 <p><b>Wall-mounted control with Modbus for Aquarea Air Smart fan coils.</b></p> <p>----- PCZ-EEB749</p>	 <p><b>Wall-mounted control with integrated Wi-Fi for Aquarea Air Smart fan coils.</b></p> <p>----- PCZ-EFB749</p>	 <p><b>3 way valve with motor for Aquarea Air Smart fan coil – Ducted.</b></p> <p>----- PCZ-V30361</p>	 <p><b>2 way valve with motor for Aquarea Air Smart fan coil – Floor standing, wall-mounted 40 and ducted.</b></p> <p>----- PCZ-V20139</p>	 <p><b>PCB for underfloor heating valve control. Requires PCZ-EEB749 or PCZ-EFB749.</b></p> <p>----- PCZ-EG1028</p>	
Replacement recirculation filter kit		Return plenum		90° shooting plenum	
 <p><b>For P-FSN25, P-FTN20, P-FSQ30 and P-FTQ30.</b></p> <p>----- PCZ-AHRD0492</p> <p><b>For P-FSN35, P-FTN25, P-FSQ45 and P-FTQ45.</b></p> <p>----- PCZ-AHRD0493</p> <p><b>For P-FSN45, P-FTN35, P-FSQ60 and P-FTQ60.</b></p> <p>----- PCZ-AHRD0494</p> <p><b>For P-FSN55, P-FTN45, P-FSQ75 and P-FTQ65.</b></p> <p>----- PCZ-AHRD0495</p>		 <p><b>With 2 circular inlets DN 160 mm. For P-FTQ30.</b></p> <p>----- PCZ-AHRD0682</p> <p><b>With 3 circular inlets DN 160 mm. For P-FTQ45.</b></p> <p>----- PCZ-AHRD0683</p> <p><b>With 4 circular inlets DN 160 mm. For P-FTQ60.</b></p> <p>----- PCZ-AHRD0684</p> <p><b>With 5 circular inlets DN 160 mm. For P-FTQ65.</b></p> <p>----- PCZ-AHRD0685</p>		 <p><b>For P-FTN20 and P-FTQ30.</b></p> <p>----- PCZ-AHRD0577</p> <p><b>For P-FTN25 and P-FTQ45.</b></p> <p>----- PCZ-AHRD0578</p> <p><b>For P-FTN35 and P-FTQ60.</b></p> <p>----- PCZ-AHRD0579</p> <p><b>For P-FTN45 and P-FTQ65.</b></p> <p>----- PCZ-AHRD0580</p>	
Plenum kit for external air connection with damper for room recirculation	Ducting plate plenum kit for outdoor air connection with damper	90° plenum for outdoor air kit with damper	Telescopic kit. For plenum for outdoor air kit with damper	Grille for telescopic kit. For plenum for outdoor air kit with damper	Non-return damper
 <p><b>For P-FTN20 and P-FTQ30.</b></p> <p>----- PCZ-AHRD0572</p> <p><b>For P-FTN25 and P-FTQ45.</b></p> <p>----- PCZ-AHRD0573</p> <p><b>For P-FTN35 and P-FTQ60.</b></p> <p>----- PCZ-AHRD0574</p> <p><b>For P-FTN45 and P-FTQ65.</b></p> <p>----- PCZ-AHRD0575</p>	 <p><b>For P-FTN20 and P-FTQ30.</b></p> <p>----- PCZ-AHRD0612</p> <p><b>For P-FTN25 and P-FTQ45.</b></p> <p>----- PCZ-AHRD0613</p> <p><b>For P-FTN35 and P-FTQ60.</b></p> <p>----- PCZ-AHRD0614</p> <p><b>For P-FTN45 and P-FTQ65.</b></p> <p>----- PCZ-AHRD0615</p>	 <p><b>For P-FTN20 and P-FTQ30.</b></p> <p>----- PCZ-AHRD0617</p> <p><b>For P-FTN25 and P-FTQ45.</b></p> <p>----- PCZ-AHRD0618</p> <p><b>For P-FTN35 and P-FTQ60.</b></p> <p>----- PCZ-AHRD0619</p> <p><b>For P-FTN45 and P-FTQ65.</b></p> <p>----- PCZ-AHRD0620</p>	 <p><b>For P-FTN20 and P-FTQ30.</b></p> <p>----- PCZ-AHRD0622</p> <p><b>For P-FTN25 and P-FTQ45.</b></p> <p>----- PCZ-AHRD0623</p> <p><b>For P-FTN35 and P-FTQ60.</b></p> <p>----- PCZ-AHRD0624</p> <p><b>For P-FTN45 and P-FTQ65.</b></p> <p>----- PCZ-AHRD0625</p>	 <p><b>For P-FTN20 and P-FTQ30.</b></p> <p>----- PCZ-AHRD0627</p> <p><b>For P-FTN25 and P-FTQ45.</b></p> <p>----- PCZ-AHRD0628</p> <p><b>For P-FTN35 and P-FTQ60.</b></p> <p>----- PCZ-AHRD0629</p> <p><b>For P-FTN45 and P-FTQ65.</b></p> <p>----- PCZ-AHRD0630</p>	 <p><b>Non-return damper. For P-FTQ and P-FSQ.</b></p> <p>----- PCZ-AHRD0519</p>











Aquarea Air Smart fan coil – Ducted multi zone accessories

Control accessories		Hydraulic accessories		
 <p><b>Wall-mounted control with Modbus for Aquarea Air Smart fan coils.</b></p> <p>----- PCZ-EEB749</p>	 <p><b>Wall-mounted control with integrated Wi-Fi for Aquarea Air Smart fan coils.</b></p> <p>----- PCZ-EFB749</p>	 <p><b>3 way valve with motor for Aquarea Air Smart fan coil – Ducted.</b></p> <p>----- PCZ-V30361</p>	 <p><b>2 way valve with motor for Aquarea Air Smart fan coil – Floor standing, wall-mounted 40 and ducted.</b></p> <p>----- PCZ-V20139</p>	 <p><b>PCB for underfloor heating valve control. Requires PCZ-EEB749 or PCZ-EFB749.</b></p> <p>----- PCZ-EG1028</p>
<p><b>Replacement recirculation filter kit</b></p>	<p><b>Return plenum</b></p>	<p><b>90° shooting plenum</b></p>	<p><b>Plenum kit for external air connection with damper for room recirculation</b></p>	
 <p><b>For P-FSN25, P-FTN20, P-FSQ30 and P-FTQ30.</b></p> <p>----- PCZ-AHRD0492</p> <p><b>For P-FSN35, P-FTN25, P-FSQ45 and P-FTQ45.</b></p> <p>----- PCZ-AHRD0493</p> <p><b>For P-FSN45, P-FTN35, P-FSQ60 and P-FTQ60.</b></p> <p>----- PCZ-AHRD0494</p> <p><b>For P-FSN55, P-FTN45, P-FSQ75 and P-FTQ65.</b></p> <p>----- PCZ-AHRD0495</p>	 <p><b>With 2 circular inlets DN 160 mm. For P-FSQ30.</b></p> <p>----- PCZ-AHRD0466</p> <p><b>With 3 circular inlets DN 160 mm. For P-FSQ45.</b></p> <p>----- PCZ-AHRD0467</p> <p><b>With 4 circular inlets DN 160 mm. For P-FSQ60.</b></p> <p>----- PCZ-AHRD0468</p> <p><b>With 5 circular inlets DN 160 mm. For P-FSQ75.</b></p> <p>----- PCZ-AHRD0469</p>	 <p><b>For P-FSN25 and P-FSQ30.</b></p> <p>----- PCZ-AHRD0522</p> <p><b>For P-FSN35 and P-FSQ45.</b></p> <p>----- PCZ-AHRD0523</p> <p><b>For P-FSN45 and P-FSQ60.</b></p> <p>----- PCZ-AHRD0524</p> <p><b>For P-FSN55 and P-FSQ75.</b></p> <p>----- PCZ-AHRD0525</p>	 <p><b>For P-FSN25 and P-FSQ30.</b></p> <p>----- PCZ-AHRD0640</p> <p><b>For P-FSN35 and P-FSQ45.</b></p> <p>----- PCZ-AHRD0641</p> <p><b>For P-FSN45 and P-FSQ60.</b></p> <p>----- PCZ-AHRD0642</p> <p><b>For P-FSN55 and P-FSQ75.</b></p> <p>----- PCZ-AHRD0643</p>	
<p><b>90° plenum for outdoor air kit with damper</b></p>	<p><b>Telescopic kit. For plenum for outdoor air kit with damper</b></p>	<p><b>Grille for telescopic kit. For plenum for outdoor air kit with damper</b></p>	<p><b>Non-return damper</b></p>	
 <p><b>For P-FSN25 and P-FSQ30.</b></p> <p>----- PCZ-AHRD0657</p> <p><b>For P-FSN35 and P-FSQ45.</b></p> <p>----- PCZ-AHRD0658</p> <p><b>For P-FSN45 and P-FSQ60.</b></p> <p>----- PCZ-AHRD0659</p> <p><b>For P-FSN55 and P-FSQ75.</b></p> <p>----- PCZ-AHRD0660</p>	 <p><b>For P-FSN25 and P-FSQ30.</b></p> <p>----- PCZ-AHRD0662</p> <p><b>For P-FSN35 and P-FSQ45.</b></p> <p>----- PCZ-AHRD0663</p> <p><b>For P-FSN45 and P-FSQ60.</b></p> <p>----- PCZ-AHRD0664</p> <p><b>For P-FSN55 and P-FSQ75.</b></p> <p>----- PCZ-AHRD0665</p>	 <p><b>For P-FSN25 and P-FSQ30.</b></p> <p>----- PCZ-AHRD0667</p> <p><b>For P-FSN35 and P-FSQ45.</b></p> <p>----- PCZ-AHRD0668</p> <p><b>For P-FSN45 and P-FSQ60.</b></p> <p>----- PCZ-AHRD0669</p> <p><b>For P-FSN55 and P-FSQ75.</b></p> <p>----- PCZ-AHRD0670</p>	 <p><b>Non-return damper. For P-FTQ and P-FSQ.</b></p> <p>----- PCZ-AHRD0519</p>	











**Flex Air Smart fan coil – Wall-mounted**

 <p><b>CONEX wired remote controller (non-wireless), white.</b></p> <p>----- CZ-RTC6W</p>	 <p><b>CONEX wired remote controller with Bluetooth®, white.</b></p> <p>----- CZ-RTC6WBL</p>	 <p><b>CONEX wired remote controller with Wi-Fi and Bluetooth®, white.</b></p> <p>----- CZ-RTC6WBLW2</p>	 <p><b>CONEX wired remote controller (non-wireless), black.</b></p> <p>----- CZ-RTC6</p>	 <p><b>CONEX wired remote controller with Bluetooth®, black.</b></p> <p>----- CZ-RTC6BL</p>	 <p><b>CONEX wired remote controller with Wi-Fi and Bluetooth®, black.</b></p> <p>----- CZ-RTC6BLW2</p>
 <p><b>Design wired remote controller with Econavi function.</b></p> <p>----- CZ-RTC5B</p>	 <p><b>Infrared remote controller.</b></p> <p>----- CZ-RWS3</p>	 <p><b>Econavi energy saving sensor.</b></p> <p>----- CZ-CENSC1</p>	 <p><b>Wired remote controller for 2-pipe and 4-pipe, EC fan coil (control + Modbus).</b></p> <p>----- PAW-FC-903EC</p>		
 <p><b>System controller for 64 indoor units with weekly timer.</b></p> <p>----- CZ-64ESMC3</p>		 <p><b>Intelligent controller (touch screen/web server) to control up to 256 indoors with included load distribution ratio (LDR).</b></p> <p>----- CZ-256ESMC3</p>	 <p><b>Central ON / OFF controller, up to 16 groups, 64 indoor units.</b></p> <p>----- CZ-ANC3</p>		







**Flex Air Smart fan coil – Medium static pressure duct**

 <p><b>Smart controller. Mini building management system, up to 15 zones and 31 units.</b></p> <p>----- SRC</p>	 <p><b>CONEX wired remote controller (non-wireless), white.</b></p> <p>----- CZ-RTC6W</p>	 <p><b>CONEX wired remote controller with Bluetooth®, white.</b></p> <p>----- CZ-RTC6WBL</p>	 <p><b>CONEX wired remote controller with Wi-Fi and Bluetooth®, white.</b></p> <p>----- CZ-RTC6WBLW2</p>	 <p><b>CONEX wired remote controller (non-wireless), black.</b></p> <p>----- CZ-RTC6</p>	 <p><b>CONEX wired remote controller with Bluetooth®, black.</b></p> <p>----- CZ-RTC6BL</p>
 <p><b>CONEX wired remote controller with Wi-Fi and Bluetooth®, black.</b></p> <p>----- CZ-RTC6BLW2</p>	 <p><b>Infrared remote controller and receiver for all indoor units.</b></p> <p>----- CZ-RWS3 + CZ-RWRC3</p>	 <p><b>Wired remote controller with touch control for 2-pipe and 4-pipe, EC fan coil (control + Modbus).</b></p> <p>----- PAW-FC-907EC</p>		 <p><b>Wired remote controller for 2-pipe and 4-pipe, EC fan coil (control + Modbus).</b></p> <p>----- PAW-FC-903EC</p>	











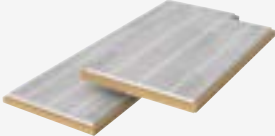

Flex Air fan coils

 <p><b>Electro-mechanical controller (supplied loose).</b></p> <p>-----</p> <p>TRM-FA</p>	 <p><b>Electronic controller.</b></p> <p>-----</p> <p>Plogic</p>	 <p><b>Electronic controller.</b></p> <p>-----</p> <p>TControl EASY 3S</p>	 <p><b>Electronic controller.</b></p> <p>-----</p> <p>TControl POD glass</p>
 <p><b>Wired remote controller with touch control for 2-pipe and 4-pipe, EC fan coil (control + Modbus).</b></p> <p>-----</p> <p>PAW-FC-907EC</p> <p><b>Wired remote controller with touch control for 2-pipe, AC fan coil (control only).</b></p> <p>-----</p> <p>PAW-FC-907AC</p>	 <p><b>Wired remote controller for 2-pipe and 4-pipe, EC fan coil (control + Modbus).</b></p> <p>-----</p> <p>PAW-FC-903EC</p> <p><b>Wired remote controller for 2-pipe, AC fan coil (control only).</b></p> <p>-----</p> <p>PAW-FC-903AC</p>	 <p><b>Advanced wired remote controller for fan coil.</b></p> <p>-----</p> <p>PAW-FC-RC1</p>	 <p><b>Smart controller. Mini building management system, up to 15 zones and 31 units.</b></p> <p>-----</p> <p>SRC</p>
 <p><b>Plogic remote control with integrated temperature sensor.</b></p> <p>-----</p> <p>WRC / MRC</p>	 <p><b>Plogic remote control.</b></p> <p>-----</p> <p>BRC</p>	 <p><b>Plogic remote control with integrated temperature sensor.</b></p> <p>-----</p> <p>IRC</p>	



Sanitary tank accessories

 <p><b>Tank sensor with 5 m cable length.</b></p> <p>-----</p> <p>PAW-TS1</p>	 <p><b>Tank sensor with 20 m cable length.</b></p> <p>-----</p> <p>PAW-TS2</p>	 <p><b>Tank sensor with 5 m cable length and only 6 mm diameter.</b></p> <p>-----</p> <p>PAW-TS4</p>	 <p><b>Temperature sensor kit for third party tank (with copper pocket and 20 m length sensor cable).</b></p> <p>-----</p> <p>CZ-TK1</p>	 <p><b>Impressed current anode for 200 L Stainless steel tanks.</b></p> <p>-----</p> <p>PAW-EANODE2</p>	 <p><b>Impressed current anode for 300 L Stainless steel tanks.</b></p> <p>-----</p> <p>PAW-EANODE3</p>
------------------------------------------------------------------------------------------------------------------------------------------------------------------	-------------------------------------------------------------------------------------------------------------------------------------------------------------------	-----------------------------------------------------------------------------------------------------------------------------------------------------------------------------------------	------------------------------------------------------------------------------------------------------------------------------------------------------------------------------------------------------------------------------	----------------------------------------------------------------------------------------------------------------------------------------------------------------------------------------------	----------------------------------------------------------------------------------------------------------------------------------------------------------------------------------------------

Heat recovery ventilation accessories





 <p><b>Supply and extract filters kit.</b></p> <p>----- PAW-VEN-FLTKit</p>	 <p><b>Optional PCB for additional functions.</b></p> <p>----- PAW-VEN-ACCPCB</p>	 <p><b>HRV touch control panel. White frame (cable must be ordered separately).</b></p> <p>----- PAW-VEN-DPL</p>	 <p><b>Cable with plug for electrical connection between unit and control panel, type CE and CD (12 m).</b></p> <p>----- PAW-VEN-CBLEXT12</p>
 <p><b>Twin plugs for installation of several control panels type CD or CE for one unit.</b></p> <p>----- PAW-VEN-DIVPLG</p>	 <p><b>HRV touch control panel wall-mounted kit.</b></p> <p>----- PAW-VEN-DPLBOX</p>	 <p><b>CO<sub>2</sub> RH wall-mounted sensor.</b></p> <p>----- PAW-VEN-S-CO2RH-W</p>	 <p><b>CO<sub>2</sub> wall-mounted sensor.</b></p> <p>----- PAW-VEN-S-CO2-W</p>
 <p><b>CO<sub>2</sub> duct sensor.</b></p> <p>----- PAW-VEN-S-CO2-D</p>	 <p><b>Wall bracket kit for stand-alone installation on the wall.</b></p> <p>----- PAW-VEN-WBRK</p>	 <p><b>Electrical duct heater 0,6 kW (includes relay).</b></p> <p>----- PAW-VEN-HTR06</p>	 <p><b>Electrical duct heater 1,2 kW (includes relay).</b></p> <p>----- PAW-VEN-HTR12</p>

Aquarea Vent accessories

Remote controller (required, to be ordered separately)		Electrical duct heater	
			
<b>Wall-mounted control with Modbus for Aquarea Vent.</b>	<b>Wall-mounted control with integrated Wi-Fi for Aquarea Vent.</b>	<b>Electrical duct heater 0,5 kW, DN 160 mm.</b>	<b>Electrical duct heater 1,0 kW, DN 160 mm.</b>
----- PCZ-AHRP0025	----- PCZ-AHRP0026	----- PCZ-AHRP0421	----- PCZ-AHRP0422

Filters





	
<b>Spare F7 filter kit (2 pcs) for models 15Z, 20Z, 30Z, 15H and 15V.</b>	<b>Activated carbon filter (1 pc) for models 15Z, 20Z, 30Z, 15H and 15V.</b>
----- PCZ-AHRP0501	----- PCZ-AHRP0901
<b>Spare F7 filter kit (2 pcs) for models 30H.</b>	<b>Activated carbon filter (1 pc) for models 30H.</b>
----- PCZ-AHRP0507	----- PCZ-AHRP0508
<b>Spare F7 filter kit (2 pcs) for models 30V.</b>	<b>Activated carbon filter (1 pc) for models 30V.</b>
----- PCZ-AHRP0502	----- PCZ-AHRP0902
<b>Spare F7 filter kit (2 pcs) for models 35H and 45H.</b>	<b>Activated carbon filter (1 pc) for models 35H and 45H.</b>
----- PCZ-AHRP0503	----- PCZ-AHRP0903
<b>Spare F7 filter kit (2 pcs) for models 40V and 45V.</b>	<b>Activated carbon filter (1 pc) for models 40V and 45V.</b>
----- PCZ-AHRP0504	----- PCZ-AHRP0904

External wall grid	External roof grill		
			
<b>External wall grid with flow deviation. Stainless steel, DN 160 mm.</b>	<b>Roof terminal. Stainless steel, DN 160 mm.</b>	<b>Through for flat roof terminal. Stainless steel, DN 160 mm.</b>	<b>Through insulation collar for roof terminal.</b>
----- PCZ-STE016181	----- PCZ-STE016185	----- PCZ-STE016190	----- PCZ-STE080189
		<b>Through for terminal inclined roof 45°. Stainless steel, DN 160 mm.</b>	
		----- PCZ-STE016191	

Primary pipe connections

 <p><b>Insulated joint male/male. DN 160 mm.</b></p> <p>----- PCZ-SRA116110</p>	 <p><b>Insulated sleeve female/female. DN 160 mm.</b></p> <p>----- PCZ-SRA116120</p>	 <p><b>Insulated reducer female/male. DN 160 mm to DN 125 mm.</b></p> <p>----- PCZ-SRA112132</p>	 <p><b>Insulated reducer female/male. DN 200 mm to DN 160 mm.</b></p> <p>----- PCZ-SRA116132</p>
--------------------------------------------------------------------------------------------------------------------------------------------------------------------------	-------------------------------------------------------------------------------------------------------------------------------------------------------------------------------	---------------------------------------------------------------------------------------------------------------------------------------------------------------------------------------------	---------------------------------------------------------------------------------------------------------------------------------------------------------------------------------------------

Primary EPP connections

 <p><b>Rigid insulated pipe (primary EPP pipe). DN 160 mm, L= 1 mt, 1 joint included.</b></p> <p>----- PCZ-SCS116001</p>	 <p><b>Elbow 90° (primary EPP pipe). DN 160 mm, 1 joint included.</b></p> <p>----- PCZ-SCS116090</p>	 <p><b>Connection joint (primary EPP pipe). DN 160 mm.</b></p> <p>----- PCZ-SCS116160</p>	 <p><b>Reducer (primary EPP pipe). DN 160 mm to DN 125mm.</b></p> <p>----- PCZ-SCS116120</p>
---------------------------------------------------------------------------------------------------------------------------------------------------------------------------------------------------------------	-----------------------------------------------------------------------------------------------------------------------------------------------------------------------------------------------	----------------------------------------------------------------------------------------------------------------------------------------------------------------------------------	-----------------------------------------------------------------------------------------------------------------------------------------------------------------------------------------







Primary flexible pipe

Flexible pipe connections

Silencers

 <p><b>10 m primary flexible duct with insulated hose. DH 160 mm.</b></p> <p>----- PCZ-SCE116010</p>	 <p><b>10 m primary flexible duct with insulated aluphonic hose. DH 160 mm.</b></p> <p>----- PCZ-SCE316010</p>	 <p><b>Hose clamp for hose. 60/325 mm.</b></p> <p>----- PCZ-SCE099120</p>	 <p><b>Black air-tight anti-condensation tape. 50 mm x 10 m.</b></p> <p>----- PCZ-SCE199121</p>	 <p><b>Aluminium tape. 50 mm x 10 m. Sp 40 µm.</b></p> <p>----- PCZ-SCE199122</p>	 <p><b>Flexible silencer male/male. DN 160 mm, SP 25 mm, L= 1000 mm.</b></p> <p>----- PCZ-SCE216001</p>
------------------------------------------------------------------------------------------------------------------------------------------------------------------------------------------------	----------------------------------------------------------------------------------------------------------------------------------------------------------------------------------------------------------	-----------------------------------------------------------------------------------------------------------------------------------------------------------------	-------------------------------------------------------------------------------------------------------------------------------------------------------------------------------------------	-----------------------------------------------------------------------------------------------------------------------------------------------------------------------------	-----------------------------------------------------------------------------------------------------------------------------------------------------------------------------------------------------

Distribution manifolds and accessories

 <p><b>TG1 insulated steel manifold with inspection door and side/front/perpendicular exits. 1x DN 160 mm - 4+4+4x DN 75/90 mm.</b></p> <p>----- PCZ-SCO164044</p>	 <p><b>TG2 insulated steel manifold with inspection door and side/front/perpendicular exits. 1x DN 160 mm - 4+8+4x DN 75/90 mm.</b></p> <p>----- PCZ-SCO164084</p>	 <p><b>TG3 insulated steel manifold with inspection door and side/front/perpendicular exits. 1x DN 160 mm - 4+12+4x DN 75/90 mm.</b></p> <p>----- PCZ-SCO164124</p>
 <p><b>Manifold/ plenum coupling for DN 75 mm corrugated start.</b></p> <p>----- PCZ-SRS075140</p>	 <p><b>Collector blind plug for manifold.</b></p> <p>----- PCZ-SRS080141</p>	 <p><b>Static flow regulator. 15=&gt; 50 m³/h, step minimum= 5 m³/h.</b></p> <p>----- PCZ-SRP080001</p>

Corrugated pipe system with accessories

 <p><b>50 m corrugated pipe coil. DN 75 mm.</b></p> <p>----- PCZ-SRS075050</p>	 <p><b>O-Ring. DN 75 mm.</b></p> <p>----- PCZ-SRS075145</p>	 <p><b>Corrugated pipe blind plug. DN 75 mm.</b></p> <p>----- PCZ-SRS075150</p>	 <p><b>Joint male/male. DN 75 mm including two O-ring.</b></p> <p>----- PCZ-SRS075120</p>	 <p><b>Fixing clip. DN 75 mm. Use every 1,5 - 2 m linear and before and after each curve.</b></p> <p>----- PCZ-SRS075155</p>	 <p><b>90° vertical angle. DN 75 mm. Two O-rings included.</b></p> <p>----- PCZ-SRS075160</p>
--------------------------------------------------------------------------------------------------------------------------------------------------------------------	--------------------------------------------------------------------------------------------------------------------------------------------------	----------------------------------------------------------------------------------------------------------------------------------------------------------------------	--------------------------------------------------------------------------------------------------------------------------------------------------------------------------------	---------------------------------------------------------------------------------------------------------------------------------------------------------------------------------------------------------------------	--------------------------------------------------------------------------------------------------------------------------------------------------------------------------------------

Room plenum

 <p><b>EPP polypropylene diffuser, modular and patented with 75/90 mm coupling, coupling for modular coupling, filter and installation brackets.</b></p> <p>----- PCZ-REV081111</p>	<p><b>Replacement filter (10 pcs).</b></p> <p>----- PCZ-SB0130860</p>
--------------------------------------------------------------------------------------------------------------------------------------------------------------------------------------------------------------------------------------------------------------------------	---------------------------------------------------------------------------

Room grills with round holes

			
<p><b>Grid 1x perforated round hole. Steel, white finish, 190 x 140 mm.</b></p> <p>----- PCZ-SB0130801</p>	<p><b>Grid 2x perforated round hole. Steel, white finish, 360 x 140 mm.</b></p> <p>----- PCZ-SB0300801</p>	<p><b>Grid 3x perforated round hole. Steel, white finish, 540 x 140 mm.</b></p> <p>----- PCZ-SB0480801</p>	<p><b>Grid 4x perforated round hole. Steel, white finish, 360 x 260 mm.</b></p> <p>----- PCZ-SB0302001</p>

Room grills with square holes

			
<p><b>Grid 1x perforated square hole. Steel, white finish, 190 x 140 mm.</b></p> <p>----- PCZ-SB0130802</p>	<p><b>Grid 2x perforated square hole. Steel, white finish, 360 x 140 mm.</b></p> <p>----- PCZ-SB0300802</p>	<p><b>Grid 3x perforated square hole. Steel, white finish, 540 x 140 mm.</b></p> <p>----- PCZ-SB0480802</p>	<p><b>Grid 5x perforated square hole. Steel, white finish, 360 x 260 mm.</b></p> <p>----- PCZ-SB0302002</p>

# Heating and cooling capacity tables

Based on outlet temperature and outside temperature.

## Aquarea T-CAP Hydraulic M Series. Three phase · R290

### WH-WXG09ME5

Tamb	HC	IP	COP	HC	IP	COP	HC	IP	COP	HC	IP	COP	HC	IP	COP	HC	IP	COP
LWC	25	25	25	35	35	35	45	45	45	55	55	55	65	65	65	75	75	75
-25	7,90	3,50	2,26	8,20	4,20	1,95	7,90	4,80	1,65	7,60	5,70	1,33	—	—	—	—	—	—
-20	7,90	2,94	2,69	8,20	3,34	2,46	7,90	3,99	1,98	7,60	4,76	1,60	7,10	5,30	1,34	—	—	—
-15	9,00	2,74	3,28	9,00	3,30	2,73	9,00	3,97	2,27	9,00	4,48	2,01	9,00	5,27	1,71	8,20	6,50	1,26
-7	9,00	2,26	3,98	9,00	2,61	3,45	9,00	3,35	2,69	9,00	3,83	2,35	9,00	4,68	1,92	9,00	5,90	1,53
2	8,80	1,95	4,51	9,00	2,36	3,81	9,00	2,91	3,09	9,00	3,54	2,54	9,00	4,29	2,10	9,00	5,50	1,64
7	9,00	1,24	7,26	9,00	1,72	5,23	9,00	2,30	3,91	9,00	2,78	3,24	9,00	3,46	2,60	8,90	4,98	1,79
25	7,20	0,86	8,37	9,00	1,08	8,33	9,00	1,55	5,81	9,00	2,05	4,39	9,00	2,68	3,36	8,40	3,45	2,43

### WH-WXG12ME5

Tamb	HC	IP	COP	HC	IP	COP	HC	IP	COP	HC	IP	COP	HC	IP	COP	HC	IP	COP
LWC	25	25	25	35	35	35	45	45	45	55	55	55	65	65	65	75	75	75
-25	10,20	4,90	2,08	10,50	5,55	1,89	9,50	5,75	1,65	8,65	5,90	1,47	—	—	—	—	—	—
-20	11,00	4,25	2,59	11,20	4,75	2,36	10,00	5,00	2,00	10,00	5,70	1,75	9,10	5,80	1,57	—	—	—
-15	12,00	4,27	2,81	12,00	4,56	2,63	11,50	5,42	2,12	11,00	5,50	2,00	10,00	5,88	1,70	9,00	6,10	1,48
-7	11,50	3,68	3,13	12,00	4,00	3,00	12,00	5,02	2,39	12,00	5,53	2,17	11,00	6,01	1,83	10,00	6,20	1,61
2	11,50	2,92	3,94	12,00	3,39	3,54	12,00	4,20	2,86	12,00	4,95	2,42	12,00	5,94	2,02	10,50	6,20	1,69
7	12,00	1,93	6,22	12,00	2,37	5,06	12,00	3,13	3,83	12,00	3,71	3,23	12,00	4,62	2,60	12,00	6,10	1,97
25	9,80	1,10	8,91	12,00	1,40	8,57	12,00	2,00	6,00	12,00	2,60	4,62	12,00	3,26	3,68	12,00	3,92	3,06

### WH-WXG09ME8

Tamb	HC	IP	COP	HC	IP	COP	HC	IP	COP	HC	IP	COP	HC	IP	COP	HC	IP	COP
LWC	25	25	25	35	35	35	45	45	45	55	55	55	65	65	65	75	75	75
-25	7,90	3,50	2,26	8,20	4,20	1,95	7,90	4,80	1,65	7,60	5,70	1,33	—	—	—	—	—	—
-20	7,90	2,94	2,69	8,20	3,34	2,46	7,90	3,99	1,98	7,60	4,76	1,60	7,10	5,30	1,34	—	—	—
-15	9,00	2,74	3,28	9,00	3,30	2,73	9,00	3,97	2,27	9,00	4,48	2,01	9,00	5,27	1,71	8,20	6,50	1,26
-7	9,00	2,26	3,98	9,00	2,61	3,45	9,00	3,35	2,69	9,00	3,83	2,35	9,00	4,68	1,92	9,00	5,90	1,53
2	8,80	1,95	4,51	9,00	2,36	3,81	9,00	2,91	3,09	9,00	3,54	2,54	9,00	4,29	2,10	9,00	5,50	1,64
7	9,00	1,24	7,26	9,00	1,72	5,23	9,00	2,30	3,91	9,00	2,78	3,24	9,00	3,46	2,60	8,90	4,98	1,79
25	7,20	0,86	8,37	9,00	1,08	8,33	9,00	1,55	5,81	9,00	2,05	4,39	9,00	2,68	3,36	8,40	3,45	2,43

### WH-WXG12ME8

Tamb	HC	IP	COP	HC	IP	COP	HC	IP	COP	HC	IP	COP	HC	IP	COP	HC	IP	COP
LWC	25	25	25	35	35	35	45	45	45	55	55	55	65	65	65	75	75	75
-25	10,20	4,90	2,08	10,50	5,55	1,89	9,80	6,70	1,46	9,70	7,40	1,31	—	—	—	—	—	—
-20	11,00	4,25	2,59	11,20	4,75	2,36	11,00	5,50	2,00	10,20	6,45	1,67	10,30	7,95	1,36	—	—	—
-15	12,00	4,27	2,81	12,00	4,56	2,63	12,00	5,67	2,12	12,00	6,00	2,00	12,00	7,06	1,70	11,00	8,45	1,30
-7	11,50	3,68	3,13	12,00	4,00	3,00	12,00	5,02	2,39	12,00	5,53	2,17	12,00	6,57	1,83	11,60	7,30	1,59
2	11,50	2,92	3,94	12,00	3,39	3,54	12,00	4,20	2,86	12,00	4,95	2,42	12,00	5,94	2,02	12,00	7,30	1,64
7	12,00	1,93	6,22	12,00	2,37	5,06	12,00	3,13	3,83	12,00	3,71	3,23	12,00	4,62	2,60	12,00	6,10	1,97
25	9,80	1,10	8,91	12,00	1,40	8,57	12,00	2,00	6,00	12,00	2,60	4,62	12,00	3,26	3,68	12,00	3,92	3,06

### WH-WXG16ME8

Tamb	HC	IP	COP	HC	IP	COP	HC	IP	COP	HC	IP	COP	HC	IP	COP	HC	IP	COP
LWC	25	25	25	35	35	35	45	45	45	55	55	55	65	65	65	75	75	75
-25	14,20	6,80	2,09	14,20	7,80	1,82	14,20	8,60	1,65	14,00	10,53	1,33	—	—	—	—	—	—
-20	14,20	5,40	2,63	14,20	6,10	2,33	14,20	6,90	2,06	14,20	8,10	1,75	14,20	10,16	1,40	—	—	—
-15	16,00	5,90	2,71	16,00	6,70	2,39	16,00	7,70	2,08	16,00	8,70	1,84	16,00	10,15	1,58	14,20	10,90	1,30
-7	16,00	5,40	2,96	16,00	6,32	2,53	16,00	7,10	2,25	16,00	8,12	1,97	16,00	9,40	1,70	16,00	10,30	1,55
2	16,00	3,63	4,41	16,00	4,85	3,30	16,00	5,88	2,72	16,00	6,75	2,37	16,00	8,15	1,96	16,00	9,99	1,60
7	16,00	2,70	5,93	16,00	3,27	4,89	16,00	4,19	3,82	16,00	5,00	3,20	16,00	6,30	2,54	16,00	7,60	2,11
25	16,00	1,45	11,03	16,00	1,99	8,04	16,00	2,85	5,61	16,00	3,65	4,38	16,00	4,75	3,37	16,00	6,30	2,54

Tamb: Ambient Temperature [°C]. LWC: Leaving Water Condenser Temperature [°C]. HC: Heating Capacity (kW). CC: Cooling Capacity (kW). IP: Input Power (kW). This data is measured by Panasonic in accordance with EN 14511-2 standard. This data is for reference purpose only, and does not guarantee the performance.

### Aquarea T-CAP Hydraulic M Series. Three phase · R290

#### WH-WXG09ME5

Tamb	CC	IP	EER	CC	IP	EER	CC	IP	EER
<b>LWC</b>	<b>7</b>	<b>7</b>	<b>7</b>	<b>14</b>	<b>14</b>	<b>14</b>	<b>18</b>	<b>18</b>	<b>18</b>
16	9,80	2,00	4,90	11,00	2,04	5,39	10,80	1,38	7,83
25	9,30	2,28	4,08	10,50	2,35	4,47	10,20	1,49	6,85
35	9,00	2,49	3,61	9,80	2,63	3,73	9,00	1,71	5,26
43	8,40	2,80	3,00	9,00	2,88	3,13	8,60	2,00	4,30

#### WH-WXG12ME5

Tamb	CC	IP	EER	CC	IP	EER	CC	IP	EER
<b>LWC</b>	<b>7</b>	<b>7</b>	<b>7</b>	<b>14</b>	<b>14</b>	<b>14</b>	<b>18</b>	<b>18</b>	<b>18</b>
16	12,00	2,50	4,80	13,70	2,60	5,27	12,00	1,73	6,94
25	12,00	3,05	3,93	13,50	3,12	4,33	12,00	1,88	6,38
35	12,00	4,21	2,85	13,20	3,25	4,06	12,00	2,80	4,29
43	9,60	4,35	2,21	10,00	4,35	2,30	12,00	3,60	3,33

#### WH-WXG09ME8

Tamb	CC	IP	EER	CC	IP	EER	CC	IP	EER
<b>LWC</b>	<b>7</b>	<b>7</b>	<b>7</b>	<b>14</b>	<b>14</b>	<b>14</b>	<b>18</b>	<b>18</b>	<b>18</b>
16	9,80	2,00	4,90	11,00	2,04	5,39	10,80	1,38	7,83
25	9,30	2,28	4,08	10,50	2,35	4,47	10,20	1,49	6,85
35	9,00	2,49	3,61	9,80	2,63	3,73	9,00	1,71	5,26
43	8,40	2,80	3,00	9,00	2,88	3,13	8,60	2,00	4,30

#### WH-WXG12ME8

Tamb	CC	IP	EER	CC	IP	EER	CC	IP	EER
<b>LWC</b>	<b>7</b>	<b>7</b>	<b>7</b>	<b>14</b>	<b>14</b>	<b>14</b>	<b>18</b>	<b>18</b>	<b>18</b>
16	12,00	2,50	4,80	13,70	2,60	5,27	12,00	1,73	6,94
25	12,00	3,05	3,93	13,50	3,12	4,33	12,00	1,88	6,38
35	12,00	4,21	2,85	13,20	3,25	4,06	12,00	2,80	4,29
43	10,80	4,89	2,21	11,20	4,87	2,30	12,00	3,60	3,33

#### WH-WXG16ME8

Tamb	CC	IP	EER	CC	IP	EER	CC	IP	EER
<b>LWC</b>	<b>7</b>	<b>7</b>	<b>7</b>	<b>14</b>	<b>14</b>	<b>14</b>	<b>18</b>	<b>18</b>	<b>18</b>
16	15,50	3,00	5,17	15,80	2,75	5,75	16,00	2,50	6,40
25	15,00	3,75	4,00	15,50	3,40	4,56	16,00	3,10	5,16
35	14,50	5,05	2,87	14,50	4,50	3,22	15,50	3,95	3,92
43	12,00	5,15	2,33	12,00	5,20	2,31	15,00	5,35	2,80

Tamb: Ambient Temperature (°C). LWC: Leaving Water Condenser Temperature (°C). HC: Heating Capacity (kW). CC: Cooling Capacity (kW). IP: Input Power (kW). This data is measured by Panasonic in accordance with EN 14511-2 standard. This data is for reference purpose only, and does not guarantee the performance.

# Heating and cooling capacity tables

Based on outlet temperature and outside temperature.

## Big Aquarea T-CAP Hydraulic Stand-alone M Series. Three phase · R290

WH-WXG20ME8																		
Tamb	HC	IP	COP	HC	IP	COP	HC	IP	COP	HC	IP	COP	HC	IP	COP	HC	IP	COP
LWC	25	25	25	35	35	35	45	45	45	55	55	55	65	65	65	75	75	75
-25	20,00	9,15	2,19	20,00	11,23	1,78	20,00	13,32	1,50	—	—	—	—	—	—	—	—	—
-20	20,00	8,55	2,34	20,00	10,50	1,90	20,00	12,45	1,61	20,00	14,40	1,39	On request			—	—	—
-15	20,00	6,80	2,94	20,00	8,53	2,34	20,00	10,27	1,95	20,00	12,00	1,67	20,00	10,45	1,91	—	—	—
-7	20,00	6,83	2,93	20,00	8,05	2,48	20,00	9,28	2,16	20,00	10,50	1,90	20,00	10,60	1,89	—	—	—
2	20,00	3,99	5,01	20,00	5,90	3,39	20,00	7,81	2,56	20,00	9,61	2,08	20,00	11,00	1,82	—	—	—
7	20,00	2,50	8,00	20,00	4,17	4,80	20,00	5,84	3,42	20,00	6,28	3,18	20,00	9,16	2,18	—	—	—
25	20,00	2,33	8,58	20,00	2,60	7,69	20,00	2,87	6,97	20,00	3,14	6,37	20,00	4,03	4,96	20,00	7,67	2,61
WH-WXG25ME8																		
Tamb	HC	IP	COP	HC	IP	COP	HC	IP	COP	HC	IP	COP	HC	IP	COP	HC	IP	COP
LWC	25	25	25	35	35	35	45	45	45	55	55	55	65	65	65	75	75	75
-25	22,00	11,34	1,94	23,00	13,80	1,67	24,00	16,26	1,48	—	—	—	—	—	—	—	—	—
-20	23,00	10,60	2,17	25,00	12,90	1,94	25,00	15,20	1,64	25,00	17,50	1,43	On request			—	—	—
-15	25,00	9,80	2,55	25,00	11,80	2,12	25,00	13,80	1,81	25,00	15,80	1,58	24,00	13,25	1,81	—	—	—
-7	25,00	7,60	3,29	25,00	10,60	2,36	25,00	13,60	1,84	25,00	13,90	1,80	25,00	14,10	1,77	—	—	—
2	25,00	6,85	3,65	25,00	8,93	2,80	25,00	11,01	2,27	25,00	12,70	1,97	25,00	13,70	1,82	—	—	—
7	25,00	3,89	6,43	25,00	5,55	4,50	25,00	7,21	3,47	25,00	8,33	3,00	25,00	11,60	2,16	—	—	—
25	25,00	3,09	8,09	25,00	3,42	7,31	25,00	3,75	6,67	25,00	4,08	6,13	25,00	5,18	4,83	25,00	9,60	2,60
WH-WXG30ME8																		
Tamb	HC	IP	COP	HC	IP	COP	HC	IP	COP	HC	IP	COP	HC	IP	COP	HC	IP	COP
LWC	25	25	25	35	35	35	45	45	45	55	55	55	65	65	65	75	75	75
-25	22,00	11,34	1,94	23,00	13,80	1,67	24,00	16,26	1,48	—	—	—	—	—	—	—	—	—
-20	23,00	10,60	2,17	25,00	12,90	1,94	25,00	15,20	1,64	25,00	17,50	1,43	On request			—	—	—
-15	27,00	13,43	2,01	30,00	15,50	1,94	30,00	17,57	1,71	30,00	19,64	1,53	25,00	14,61	1,71	—	—	—
-7	29,00	9,70	2,99	30,00	12,90	2,33	30,00	16,10	1,86	30,00	19,30	1,55	30,00	17,10	1,75	—	—	—
2	30,00	10,10	2,97	30,00	12,00	2,50	30,00	13,90	2,16	30,00	15,40	1,95	30,00	16,70	1,80	—	—	—
7	30,00	4,88	6,15	30,00	6,82	4,40	30,00	8,76	3,42	30,00	10,00	3,00	30,00	14,00	2,14	—	—	—
25	30,00	4,33	6,93	30,00	4,60	6,52	30,00	4,87	6,16	30,00	5,14	5,84	30,00	6,49	4,62	25,00	9,60	2,60

## Big Aquarea T-CAP Hydraulic Stand-alone M Series. Three phase · R290

WH-WXG20ME8									
Tamb	CC	IP	EER	CC	IP	EER	CC	IP	EER
LWC	7	7	7	14	14	14	18	18	18
16	20,00	3,22	6,21	20,00	3,10	6,45	20,00	2,99	6,69
25	20,00	4,65	4,30	20,00	4,01	4,99	20,00	3,38	5,92
35	20,00	6,62	3,02	20,00	5,40	3,70	20,00	4,18	4,78
43	20,00	9,06	2,21	20,00	7,37	2,71	20,00	5,68	3,52
WH-WXG25ME8									
Tamb	CC	IP	EER	CC	IP	EER	CC	IP	EER
LWC	7	7	7	14	14	14	18	18	18
16	25,00	4,56	5,48	25,00	4,32	5,79	25,00	4,09	6,11
25	25,00	6,35	3,94	25,00	5,45	4,59	25,00	4,57	5,47
35	25,00	8,74	2,86	25,00	7,17	3,49	25,00	5,59	4,47
43	21,80	9,44	2,31	23,40	8,63	2,71	25,00	7,54	3,32
WH-WXG30ME8									
Tamb	CC	IP	EER	CC	IP	EER	CC	IP	EER
LWC	7	7	7	14	14	14	18	18	18
16	28,00	5,14	5,45	29,00	5,19	5,59	30,00	5,23	5,74
25	28,00	6,84	4,09	29,00	6,38	4,55	30,00	5,92	5,07
35	26,00	9,70	2,68	28,00	8,51	3,29	30,00	7,32	4,10
43	21,80	9,44	2,31	25,90	9,60	2,70	30,00	9,76	3,07

Tamb: Ambient Temperature (°C). LWC: Leaving Water Condenser Temperature (°C). HC: Heating Capacity (kW). CC: Cooling Capacity (kW). IP: Input Power (kW). This data is measured by Panasonic in accordance with EN 14511-2 standard. This data is for reference purpose only, and does not guarantee the performance. \*Data to be confirmed.

## Aquarea T-CAP Mono-bloc J Series. Single phase / Three phase - MXC · R32

WH-MXC09J3E5-1																
Tamb	HC	IP	COP	HC	IP	COP	HC	IP	COP	HC	IP	COP	HC	IP	COP	
LWC	25	25	25	35	35	35	45	45	45	55	55	55	60	60	60	
-20	9,00	3,44	2,62	9,00	3,95	2,28	9,00	4,65	1,94	7,90	5,58	1,42	—	—	—	
-15	9,00	2,98	3,02	9,00	3,41	2,64	9,00	4,04	2,23	9,00	4,83	1,86	8,70	5,37	1,62	
-7	10,50	2,72	3,86	9,00	2,92	3,08	9,00	3,54	2,54	9,00	4,24	2,12	9,00	4,62	1,95	
2	10,80	2,14	5,05	9,00	2,36	3,81	9,00	2,91	3,09	9,00	3,55	2,54	9,00	4,05	2,22	
7	9,00	1,38	6,52	9,00	1,77	5,08	9,00	2,37	3,80	9,00	2,92	3,08	9,00	3,29	2,74	
25	9,00	0,77	11,69	9,00	1,00	9,00	10,00	1,67	5,99	10,00	2,28	4,39	11,00	2,86	3,85	
WH-MXC12J6E5-1																
Tamb	HC	IP	COP	HC	IP	COP	HC	IP	COP	HC	IP	COP	HC	IP	COP	
LWC	25	25	25	35	35	35	45	45	45	55	55	55	60	60	60	
-20	12,00	5,02	2,39	12,00	5,80	2,07	11,00	5,95	1,85	10,00	6,50	1,54	—	—	—	
-15	12,00	4,14	2,90	12,00	4,83	2,48	11,00	5,20	2,12	10,50	6,00	1,75	8,90	6,30	1,41	
-7	13,50	4,30	3,14	12,00	4,25	2,82	12,00	5,02	2,39	12,00	6,00	2,00	11,00	6,30	1,75	
2	14,50	3,23	4,49	12,00	3,40	3,53	12,00	4,20	2,86	12,00	4,95	2,42	12,00	5,77	2,08	
7	12,00	2,00	6,00	12,00	2,50	4,80	12,00	3,24	3,70	12,00	3,94	3,05	12,00	4,52	2,65	
25	12,00	1,20	10,00	12,00	1,49	8,05	12,00	2,10	5,71	12,00	2,75	4,36	12,00	3,11	3,86	
WH-MXC09J3E8-1																
Tamb	HC	IP	COP	HC	IP	COP	HC	IP	COP	HC	IP	COP	HC	IP	COP	
LWC	25	25	25	35	35	35	45	45	45	55	55	55	60	60	60	
-20	9,00	3,44	2,62	9,00	3,95	2,28	9,00	4,65	1,94	7,90	5,58	1,42	—	—	—	
-15	9,00	2,98	3,02	9,00	3,41	2,64	9,00	4,04	2,23	9,00	4,83	1,86	8,70	5,37	1,62	
-7	10,50	2,72	3,86	9,00	2,92	3,08	9,00	3,54	2,54	9,00	4,24	2,12	9,00	4,62	1,95	
2	10,80	2,14	5,05	9,00	2,36	3,81	9,00	2,91	3,09	9,00	3,55	2,54	9,00	4,05	2,22	
7	9,00	1,38	6,52	9,00	1,77	5,08	9,00	2,37	3,80	9,00	2,92	3,08	9,00	3,29	2,74	
25	9,00	0,77	11,69	9,00	1,00	9,00	10,00	1,67	5,99	10,00	2,28	4,39	11,00	2,86	3,85	
WH-MXC12J9E8-1																
Tamb	HC	IP	COP	HC	IP	COP	HC	IP	COP	HC	IP	COP	HC	IP	COP	
LWC	25	25	25	35	35	35	45	45	45	55	55	55	60	60	60	
-20	12,00	5,02	2,39	12,00	5,80	2,07	10,50	5,75	1,83	9,20	5,80	1,59	—	—	—	
-15	12,00	4,14	2,90	12,00	4,83	2,48	12,00	5,67	2,12	11,10	6,35	1,75	8,70	6,20	1,40	
-7	13,50	4,30	3,14	12,00	4,25	2,82	12,00	5,02	2,39	12,00	6,00	2,00	11,00	6,30	1,75	
2	14,50	3,23	4,49	12,00	3,40	3,53	12,00	4,20	2,86	12,00	4,95	2,42	12,00	5,77	2,08	
7	12,00	2,00	6,00	12,00	2,50	4,80	12,00	3,24	3,70	12,00	3,94	3,05	12,00	4,52	2,65	
25	12,00	1,20	10,00	12,00	1,49	8,05	12,00	2,10	5,71	12,00	2,75	4,36	12,00	3,11	3,86	
WH-MXC16J9E8-1																
Tamb	HC	IP	COP	HC	IP	COP	HC	IP	COP	HC	IP	COP	HC	IP	COP	
LWC	25	25	25	35	35	35	45	45	45	55	55	55	60	60	60	
-20	16,00	7,40	2,16	16,00	8,40	1,90	16,00	10,00	1,60	14,00	10,30	1,36	—	—	—	
-15	15,30	6,10	2,51	16,00	6,91	2,32	16,00	8,44	1,90	16,00	9,97	1,60	14,00	10,60	1,32	
-7	19,00	6,60	2,88	16,00	6,70	2,39	16,00	7,85	2,04	16,00	9,33	1,71	15,00	9,70	1,55	
2	20,60	5,35	3,85	16,00	5,16	3,10	16,00	6,40	2,50	16,00	7,72	2,07	16,00	9,20	1,74	
7	16,00	2,80	5,71	16,00	3,54	4,52	16,00	4,55	3,52	16,00	5,60	2,86	15,60	6,50	2,40	
25	16,00	1,55	10,32	16,00	2,30	6,96	16,00	3,20	5,00	16,00	4,00	4,00	15,50	4,50	3,44	

## Aquarea T-CAP Mono-bloc J Series. Single phase / Three phase - MXC · R32

Outdoor		WH-MXC09J3E5-1									WH-MXC12J6E5-1																	
Tamb	CC	IP	EER	CC	IP	EER	CC	IP	EER	CC	IP	EER	CC	IP	EER	CC	IP	EER										
LWC	7	7	7	14	14	14	18	18	18	7	7	7	14	14	14	18	18	18										
16	9,00	1,61	5,59	11,00	1,49	7,38	11,40	1,30	8,77	11,40	2,10	5,43	13,60	2,09	6,51	15,00	2,06	7,28										
25	9,00	2,00	4,50	12,60	2,38	5,29	10,50	1,54	6,82	12,00	2,87	4,18	15,70	3,60	4,36	14,00	2,56	5,47										
35	9,00	2,83	3,18	10,90	2,98	3,66	9,00	1,95	4,62	12,00	4,14	2,90	13,60	4,35	3,13	12,00	3,04	3,95										
43	7,20	3,26	2,21	8,70	3,23	2,69	7,30	2,43	3,00	10,30	4,89	2,11	11,80	4,98	2,37	10,40	3,72	2,80										
Outdoor		WH-MXC09J3E8-1									WH-MXC12J9E8-1									WH-MXC16J9E8-1								
Tamb	CC	IP	EER	CC	IP	EER	CC	IP	EER	CC	IP	EER	CC	IP	EER	CC	IP	EER	CC	IP	EER	CC	IP	EER				
LWC	7	7	7	14	14	14	18	18	18	7	7	7	14	14	14	18	18	18	7	7	7	14	14	14	18	18	18	
16	9,00	1,66	5,42	11,00	1,54	7,14	11,40	1,35	8,44	11,40	2,15	5,30	13,60	2,14	6,36	15,00	2,15	6,98	15,00	3,15	4,76	19,00	3,35	5,67	19,00	3,00	6,33	
25	9,00	2,06	4,37	12,60	2,45	5,14	10,50	1,60	6,56	12,00	2,93	4,10	15,70	3,68	4,27	14,00	2,66	5,26	15,00	4,00	3,75	18,00	4,00	4,50	18,00	3,50	5,14	
35	9,00	2,91	3,09	10,90	3,07	3,55	9,00	2,02	4,46	12,00	4,23	2,84	13,60	4,44	3,06	12,00	3,17	3,79	14,50	5,11	2,84	14,50	4,20	3,45	16,00	4,27	3,75	
43	7,20	3,36	2,14	8,70	3,33	2,61	7,30	2,53	2,89	10,30	5,00	2,06	11,80	5,09	2,32	10,40	3,87	2,69	9,50	4,40	2,16	11,50	4,40	2,61	12,50	4,30	2,91	

Tamb: Ambient Temperature [°C]. LWC: Leaving Water Condenser Temperature [°C]. HC: Heating Capacity (kW). CC: Cooling Capacity (kW). IP: Input Power (kW). This data is measured by Panasonic in accordance with EN 14511-2 standard. This data is for reference purpose only, and does not guarantee the performance.

# Heating and cooling capacity tables

Based on outlet temperature and outside temperature.

## Aquarea High Performance Hydraulic L Series. Single phase · R290

### WH-WDG05LE5

Tamb	HC	IP	COP	HC	IP	COP	HC	IP	COP	HC	IP	COP	HC	IP	COP
LWC	35	35	35	45	45	45	55	55	55	65	65	65	75	75	75
-25	2,45	1,76	1,39	3,80	2,30	1,65	3,60	2,46	1,46	—	—	—	—	—	—
-20	4,70	2,19	2,15	4,50	2,37	1,90	4,25	2,57	1,65	—	—	—	—	—	—
-15	5,00	1,94	2,58	5,00	2,31	2,16	5,00	2,63	1,90	4,60	2,88	1,60	—	—	—
-7	5,00	1,66	3,01	5,00	1,94	2,58	5,00	2,36	2,12	5,00	2,62	1,91	4,30	2,87	1,50
2	5,00	1,42	3,52	5,00	1,71	2,92	5,00	2,14	2,34	5,00	2,54	1,97	4,60	2,76	1,67
7	5,00	0,99	5,05	5,00	1,27	3,94	5,00	1,63	3,07	5,00	2,03	2,46	4,70	2,57	1,83

### WH-WDG07LE5

Tamb	HC	IP	COP	HC	IP	COP	HC	IP	COP	HC	IP	COP	HC	IP	COP
LWC	35	35	35	45	45	45	55	55	55	65	65	65	75	75	75
-25	4,75	2,53	1,88	4,30	2,66	1,62	3,95	2,78	1,42	—	—	—	—	—	—
-20	5,50	2,56	2,15	5,10	2,75	1,85	4,90	2,97	1,65	—	—	—	—	—	—
-15	6,00	2,50	2,40	5,50	2,60	2,12	5,20	2,89	1,80	4,80	3,00	1,60	—	—	—
-7	5,80	1,93	3,01	5,80	2,32	2,50	5,80	2,74	2,12	5,70	3,16	1,80	4,80	3,56	1,35
2	6,85	2,00	3,43	6,60	2,34	2,82	6,25	2,67	2,34	5,60	2,80	2,00	5,00	3,13	1,60
7	7,00	1,42	4,93	7,00	1,90	3,68	7,00	2,35	2,98	6,60	2,85	2,32	6,30	3,40	1,85

### WH-WDG09LE5

Tamb	HC	IP	COP	HC	IP	COP	HC	IP	COP	HC	IP	COP	HC	IP	COP
LWC	35	35	35	45	45	45	55	55	55	65	65	65	75	75	75
-25	6,05	3,43	1,76	5,25	3,28	1,60	4,65	3,15	1,48	—	—	—	—	—	—
-20	7,00	3,56	1,97	6,20	3,50	1,77	5,60	3,43	1,63	—	—	—	—	—	—
-15	7,40	3,20	2,31	6,80	3,40	2,00	6,30	3,55	1,77	5,60	3,55	1,58	—	—	—
-7	7,00	2,50	2,80	7,00	2,98	2,35	7,00	3,29	2,13	6,50	3,53	1,84	5,40	3,56	1,52
2	7,00	2,05	3,41	7,00	2,50	2,80	7,00	2,90	2,41	6,70	3,35	2,00	5,70	3,40	1,68
7	9,00	1,98	4,55	9,00	2,58	3,49	8,90	2,94	3,03	8,90	3,56	2,50	7,30	3,56	2,05

## Aquarea High Performance Hydraulic L Series. Single phase · R290

### WH-WDG05LE5

Tamb	CC	IP	EER	CC	IP	EER	CC	IP	EER
LWC	7	7	7	14	14	14	18	18	18
16	6,00	1,01	5,94	7,50	1,05	7,14	6,00	0,67	8,96
25	5,70	1,20	4,75	7,00	1,20	5,83	5,70	0,78	7,31
35	5,00	1,55	3,23	6,30	1,44	4,38	5,00	1,00	5,00
43	4,50	1,60	2,81	5,60	1,64	3,41	4,50	1,12	4,02

### WH-WDG07LE5

Tamb	CC	IP	EER	CC	IP	EER	CC	IP	EER
LWC	7	7	7	14	14	14	18	18	18
16	7,00	1,36	5,15	8,50	1,39	6,12	8,00	1,04	7,69
25	7,00	1,65	4,24	8,00	1,57	5,10	7,50	1,18	6,36
35	7,00	2,31	3,03	8,00	2,26	3,54	7,00	1,48	4,73
43	6,00	2,50	2,40	7,00	2,60	2,69	5,70	1,70	3,35

### WH-WDG09LE5

Tamb	CC	IP	EER	CC	IP	EER	CC	IP	EER
LWC	7	7	7	14	14	14	18	18	18
16	9,00	2,00	4,50	11,00	2,12	5,19	11,00	1,80	6,11
25	9,00	2,50	3,60	11,00	2,60	4,23	10,00	1,85	5,41
35	8,20	2,91	2,82	10,00	3,10	3,23	9,00	2,15	4,19
43	6,40	2,67	2,40	7,40	2,70	2,74	8,20	2,50	3,28

Tamb: Ambient Temperature [°C]. LWC: Leaving Water Condenser Temperature [°C]. HC: Heating Capacity [kW]. CC: Cooling Capacity [kW]. IP: Input Power [kW]. This data is measured by Panasonic in accordance with EN 14511-2 standard. This data is for reference purpose only, and does not guarantee the performance.

### Aquarea High Performance Hydraulic M Series. Single phase · R290

WH-WDG12ME5															
Tamb	HC	IP	COP	HC	IP	COP	HC	IP	COP	HC	IP	COP	HC	IP	COP
LWC	35	35	35	45	45	45	55	55	55	65	65	65	75	75	75
-25	7,20	3,85	1,87	7,10	4,68	1,52	7,10	5,68	1,25	—	—	—	—	—	—
-20	8,10	3,85	2,10	7,80	4,49	1,74	7,80	5,21	1,50	7,35	6,40	1,15	—	—	—
-15	9,40	3,78	2,49	9,00	4,44	2,03	8,80	5,20	1,69	8,60	6,40	1,34	6,40	6,20	1,03
-7	10,50	3,50	3,00	10,20	4,43	2,30	10,00	5,08	1,97	9,80	6,40	1,53	7,90	6,40	1,23
2	12,50	3,71	3,37	12,00	4,35	2,76	12,00	5,29	2,27	11,00	6,20	1,77	9,00	6,20	1,45
7	14,80	3,14	4,71	14,20	3,88	3,66	14,10	4,67	3,02	12,90	5,56	2,32	11,00	6,40	1,72
WH-WDG16ME5															
Tamb	HC	IP	COP	HC	IP	COP	HC	IP	COP	HC	IP	COP	HC	IP	COP
LWC	35	35	35	45	45	45	55	55	55	65	65	65	75	75	75
-25	8,30	4,68	1,77	7,55	5,05	1,50	7,15	5,70	1,25	—	—	—	—	—	—
-20	9,00	4,36	2,06	8,45	4,92	1,72	8,20	5,57	1,47	7,35	6,40	1,15	—	—	—
-15	10,50	4,38	2,40	9,90	4,95	2,00	9,30	5,57	1,67	8,60	6,40	1,34	6,40	6,20	1,03
-7	11,70	4,45	2,63	11,30	5,14	2,20	10,80	5,68	1,90	9,80	6,40	1,53	7,90	6,40	1,23
2	13,00	3,94	3,30	12,20	4,45	2,74	12,00	5,29	2,27	11,00	6,20	1,77	9,00	6,20	1,45
7	16,00	3,44	4,65	16,00	4,51	3,55	14,70	4,90	3,00	14,70	6,40	2,30	11,00	6,40	1,72

### Aquarea High Performance Hydraulic M Series. Single phase · R290

WH-WDG12ME5									
Tamb	CC	IP	EER	CC	IP	EER	CC	IP	EER
LWC	7	7	7	14	14	14	18	18	18
16	12,50	2,40	5,21	16,00	2,55	6,27	13,50	1,64	8,23
25	12,00	2,88	4,17	16,00	3,04	5,26	13,00	1,77	7,34
35	12,00	3,70	3,24	15,00	3,90	3,85	12,00	2,40	5,00
43	10,50	4,08	2,57	13,00	4,08	3,19	11,00	2,76	3,99
WH-WDG16ME5									
Tamb	CC	IP	EER	CC	IP	EER	CC	IP	EER
LWC	7	7	7	14	14	14	18	18	18
16	12,50	2,40	5,21	16,00	2,55	6,27	17,50	2,36	7,42
25	12,00	2,88	4,17	16,00	3,04	5,26	16,70	2,66	6,28
35	14,00	4,38	3,20	17,00	4,52	3,76	15,50	3,27	4,74
43	10,50	4,08	2,57	13,00	4,08	3,19	13,80	3,77	3,66

Tamb: Ambient Temperature [°C]. LWC: Leaving Water Condenser Temperature [°C]. HC: Heating Capacity [kW]. CC: Cooling Capacity [kW]. IP: Input Power [kW].  
This data is measured by Panasonic in accordance with EN 14511-2 standard. This data is for reference purpose only, and does not guarantee the performance.

# Heating and cooling capacity tables

Based on outlet temperature and outside temperature.

## Aquarea High Performance Mono-bloc J Series. Single phase - MDC · R32

### WH-MDC05J3E5-1

Tamb	HC	IP	COP	HC	IP	COP	HC	IP	COP	HC	IP	COP	HC	IP	COP
LWC	25	25	25	35	35	35	45	45	45	55	55	55	60	60	60
-20	4,37	1,73	2,53	4,16	2,03	2,05	3,84	2,37	1,62	3,43	2,64	1,30	—	—	—
-15	5,13	1,78	2,88	5,00	2,17	2,30	4,75	2,51	1,89	3,70	2,45	1,51	—	—	—
-7	5,17	1,49	3,47	5,00	1,80	2,78	4,80	2,16	2,22	5,00	2,70	1,85	4,68	2,71	1,73
2	5,00	1,11	4,50	5,00	1,40	3,57	5,00	1,81	2,76	5,00	2,20	2,27	4,80	2,40	2,00
7	5,09	0,78	6,53	5,00	0,99	5,05	5,00	1,31	3,82	5,00	1,66	3,01	4,58	1,90	2,41
25	4,96	0,77	6,44	5,04	0,90	5,60	5,31	1,16	4,58	5,61	1,34	4,19	5,15	1,33	3,87

### WH-MDC07J3E5-1

Tamb	HC	IP	COP	HC	IP	COP	HC	IP	COP	HC	IP	COP	HC	IP	COP
LWC	25	25	25	35	35	35	45	45	45	55	55	55	60	60	60
-20	4,86	2,03	2,39	4,66	2,35	1,98	4,44	2,75	1,61	4,23	3,13	1,35	—	—	—
-15	5,80	2,11	2,75	5,60	2,40	2,33	5,30	2,84	1,87	5,00	3,32	1,51	—	—	—
-7	6,76	2,07	3,27	6,80	2,42	2,81	6,30	2,82	2,23	6,30	3,39	1,86	4,74	2,76	1,72
2	6,83	1,66	4,11	7,00	2,06	3,40	6,85	2,50	2,74	6,30	2,92	2,16	4,80	2,40	2,00
7	7,32	1,19	6,15	7,00	1,47	4,76	7,00	1,96	3,57	7,00	2,48	2,82	6,18	2,44	2,53
25	6,80	0,64	10,63	6,67	0,93	7,17	6,79	1,38	4,92	6,70	1,80	3,72	6,22	1,78	3,49

### WH-MDC09J3E5-1

Tamb	HC	IP	COP	HC	IP	COP	HC	IP	COP	HC	IP	COP	HC	IP	COP
LWC	25	25	25	35	35	35	45	45	45	55	55	55	60	60	60
-20	5,33	2,36	2,26	6,43	3,60	1,79	5,78	3,83	1,51	4,83	3,64	1,33	—	—	—
-15	7,76	3,20	2,43	7,60	3,41	2,23	7,00	3,71	1,89	5,60	3,80	1,47	—	—	—
-7	7,39	2,45	3,02	7,50	2,85	2,63	7,30	3,37	2,17	7,00	3,89	1,80	6,44	3,67	1,75
2	7,38	1,89	3,90	7,45	2,38	3,13	7,00	2,85	2,46	7,00	3,30	2,12	5,46	2,72	2,01
7	9,15	1,59	5,75	9,00	2,01	4,48	9,00	2,61	3,45	8,95	3,22	2,78	7,25	2,87	2,53
25	8,02	0,98	8,18	7,88	1,32	5,97	8,46	1,86	4,55	7,60	2,03	3,74	6,30	1,87	3,37

## Aquarea High Performance Mono-bloc J Series. Single phase - MDC · R32

### WH-MDC05J3E5-1

Tamb	CC	IP	EER	CC	IP	EER	CC	IP	EER
LWC	7	7	7	14	14	14	18	18	18
16	5,18	0,82	6,32	6,17	0,84	7,35	5,78	0,60	9,63
25	5,38	1,22	4,41	6,64	1,25	5,31	5,55	0,78	7,12
35	5,00	1,54	3,25	5,86	1,61	3,64	5,00	0,99	5,05
43	4,19	1,85	2,26	5,36	1,92	2,79	4,37	1,30	3,36

### WH-MDC07J3E5-1

Tamb	CC	IP	EER	CC	IP	EER	CC	IP	EER
LWC	7	7	7	14	14	14	18	18	18
16	5,38	0,83	6,48	6,69	0,85	7,87	7,65	0,76	10,07
25	6,96	1,82	3,82	9,06	1,98	4,58	7,58	1,23	6,16
35	7,00	2,29	3,06	8,37	2,47	3,39	7,00	1,48	4,73
43	5,60	2,55	2,20	6,87	2,58	2,66	6,10	1,88	3,24

### WH-MDC09J3E5-1

Tamb	CC	IP	EER	CC	IP	EER	CC	IP	EER
LWC	7	7	7	14	14	14	18	18	18
16	6,89	1,21	5,69	8,65	1,23	7,03	9,82	1,19	8,25
25	9,50	2,84	3,35	11,55	3,06	3,77	9,68	1,82	5,32
35	9,00	3,32	2,71	10,10	3,51	2,88	9,00	2,12	4,25
43	5,42	2,56	2,12	6,56	2,56	2,56	7,40	2,56	2,89

Tamb: Ambient Temperature (°C). LWC: Leaving Water Condenser Temperature (°C). HC: Heating Capacity (kW). CC: Cooling Capacity (kW). IP: Input Power (kW). This data is measured by Panasonic in accordance with EN 14511-2 standard. This data is for reference purpose only, and does not guarantee the performance.

## Aquarea T-CAP Bi-bloc K Series. Single phase / Three phase · R32

## WH-UXZ09KE5

Tamb	HC	IP	COP	HC	IP	COP	HC	IP	COP	HC	IP	COP
LWC	35	35	35	45	45	45	55	55	55	60	60	60
-20	8,80	4,79	1,84	8,80	5,30	1,66	8,55	5,90	1,45	—	—	—
-15	9,00	3,45	2,61	9,00	4,30	2,09	9,00	4,95	1,82	—	—	—
-7	9,00	3,00	3,00	9,00	3,82	2,36	9,00	4,28	2,10	9,00	4,72	1,91
2	9,00	2,44	3,69	9,00	3,05	2,95	9,00	3,90	2,31	9,00	4,05	2,22
7	9,00	1,79	5,03	9,00	2,42	3,72	9,00	2,93	3,07	9,00	3,43	2,62
25	7,95	1,20	6,63	9,00	1,56	5,77	11,30	3,13	3,61	11,00	2,86	3,85

## WH-UXZ12KE5

Tamb	HC	IP	COP	HC	IP	COP	HC	IP	COP	HC	IP	COP
LWC	35	35	35	45	45	45	55	55	55	60	60	60
-20	11,50	6,05	1,90	10,20	6,02	1,69	8,70	6,00	1,45	—	—	—
-15	12,00	4,90	2,45	11,00	5,38	2,04	10,50	6,20	1,69	—	—	—
-7	12,00	4,41	2,72	12,00	5,54	2,17	12,00	6,00	2,00	11,00	6,30	1,75
2	12,00	3,49	3,44	12,00	4,25	2,82	12,00	5,24	2,29	12,00	5,77	2,08
7	12,10	2,50	4,84	12,10	3,38	3,58	12,10	3,98	3,04	12,00	4,52	2,65
25	10,90	1,61	6,77	10,87	2,44	4,45	11,30	3,13	3,61	12,00	3,11	3,86

## WH-UXZ09KE8 / WH-UQZ09KE8

Tamb	HC	IP	COP	HC	IP	COP	HC	IP	COP	HC	IP	COP
LWC	35	35	35	45	45	45	55	55	55	60	60	60
-20	8,80	4,79	1,84	8,80	5,30	1,66	8,55	5,90	1,45	—	—	—
-15	9,00	3,45	2,61	9,00	4,30	2,09	9,00	4,95	1,82	—	—	—
-7	9,00	3,00	3,00	9,00	3,82	2,36	9,00	4,28	2,10	9,00	4,72	1,91
2	9,00	2,44	3,69	9,00	3,05	2,95	9,00	3,90	2,31	9,00	4,05	2,22
7	9,00	1,79	5,03	9,00	2,42	3,72	9,00	2,93	3,07	9,00	3,43	2,62
25	7,95	1,20	6,63	9,00	1,56	5,77	11,30	3,13	3,61	11,00	2,86	3,85

## WH-UXZ12KE8 / WH-UQZ12KE8

Tamb	HC	IP	COP	HC	IP	COP	HC	IP	COP	HC	IP	COP
LWC	35	35	35	45	45	45	55	55	55	60	60	60
-20	11,50	6,05	1,90	10,20	6,02	1,69	8,70	6,00	1,45	—	—	—
-15	12,00	4,90	2,45	11,00	5,38	2,04	10,50	6,20	1,69	—	—	—
-7	12,00	4,41	2,72	12,00	5,54	2,17	12,00	5,24	2,29	11,80	6,59	1,79
2	12,00	3,49	3,44	12,00	4,25	2,82	12,00	5,24	2,29	12,00	5,77	2,08
7	12,10	2,50	4,84	12,10	3,38	3,58	12,10	3,98	3,04	12,00	4,52	2,65
25	10,90	1,61	6,77	10,87	2,44	4,45	11,30	3,13	3,61	12,00	3,11	3,86

## WH-UXZ16KE8 / WH-UQZ16KE8

Tamb	HC	IP	COP	HC	IP	COP	HC	IP	COP	HC	IP	COP
LWC	35	35	35	45	45	45	55	55	55	60	60	60
-20	16,00	8,20	1,95	15,00	9,00	1,67	12,00	9,30	1,29	—	—	—
-15	16,00	6,91	2,32	16,00	8,44	1,90	16,00	9,97	1,60	—	—	—
-7	16,00	6,70	2,39	16,00	7,85	2,04	16,00	9,33	1,71	15,00	9,70	1,55
2	16,00	5,16	3,10	16,00	6,40	2,50	16,00	7,72	2,07	16,00	9,20	1,74
7	16,00	3,65	4,38	16,00	4,72	3,39	16,00	5,88	2,72	15,20	5,90	2,58
25	16,00	2,30	6,96	16,00	3,20	5,00	16,00	4,00	4,00	14,50	4,30	3,37

## Aquarea T-CAP Bi-bloc K Series. Single phase / Three phase · R32

Outdoor		WH-UXZ09KE5									WH-UXZ12KE5																	
Tamb	CC	IP	EER	CC	IP	EER	CC	IP	EER	CC	IP	EER	CC	IP	EER	CC	IP	EER										
LWC	7	7	7	14	14	14	18	18	18	7	7	7	14	14	14	18	18	18										
25	8,98	2,37	3,79	10,60	2,41	4,40	9,00	1,57	5,73	11,10	3,35	3,31	13,03	3,43	3,80	11,63	2,34	4,97										
35	8,80	2,83	3,11	9,07	3,01	3,01	8,80	1,90	4,63	10,70	4,00	2,68	11,42	4,20	2,72	10,70	2,73	3,92										
43	6,48	3,27	1,98	7,65	3,27	2,34	6,68	2,46	2,72	6,62	3,29	2,01	7,89	3,30	2,39	8,68	3,28	2,65										
Outdoor		WH-UXZ09KE8 / WH-UQZ09KE8									WH-UXZ12KE8 / WH-UQZ12KE8									WH-UXZ16KE8 / WH-UQZ16KE8								
Tamb	CC	IP	EER	CC	IP	EER	CC	IP	EER	CC	IP	EER	CC	IP	EER	CC	IP	EER	CC	IP	EER	CC	IP	EER				
LWC	7	7	7	14	14	14	18	18	18	7	7	7	14	14	14	18	18	18	7	7	7	14	14	14	18	18	18	
25	8,98	2,37	3,79	10,60	2,41	4,40	9,00	1,57	5,73	11,10	3,35	3,31	13,03	3,43	3,80	11,63	2,34	4,97	15,00	4,00	3,75	17,00	4,20	4,05	17,00	3,40	5,00	
35	8,80	2,83	3,11	9,07	3,01	3,01	8,80	1,90	4,63	10,70	4,00	2,68	11,42	4,20	2,72	10,70	2,73	3,92	13,40	5,08	2,64	15,50	5,30	2,92	13,40	5,08	2,64	
43	6,48	3,27	1,98	7,65	3,27	2,34	6,68	2,46	2,72	6,62	3,29	2,01	7,89	3,30	2,39	8,68	3,28	2,65	8,80	4,20	2,10	10,50	4,30	2,44	11,50	4,20	2,74	

Tamb: Ambient Temperature (°C). LWC: Leaving Water Condenser Temperature (°C). HC: Heating Capacity (kW). CC: Cooling Capacity (kW). IP: Input Power (kW). This data is measured by Panasonic in accordance with EN 14511-2 standard. This data is for reference purpose only, and does not guarantee the performance.

# Heating and cooling capacity tables

Based on outlet temperature and outside temperature.

## Aquarea High Performance Bi-bloc K Series. Single phase · R32

### WH-UDZ03KE5

Tamb	HC	IP	COP	HC	IP	COP	HC	IP	COP	HC	IP	COP	HC	IP	COP
LWC	25	25	25	35	35	35	45	45	45	55	55	55	60	60	60
-20	2,50	1,11	2,25	2,52	1,31	1,92	2,24	1,59	1,41	2,12	1,80	1,18	—	—	—
-15	3,00	1,14	2,63	3,20	1,37	2,34	3,00	1,62	1,85	2,75	1,92	1,43	—	—	—
-7	2,99	0,91	3,29	3,30	1,18	2,80	3,25	1,47	2,21	3,20	1,79	1,79	3,00	1,88	1,60
2	2,92	0,69	4,23	3,20	0,88	3,64	3,20	1,13	2,83	3,20	1,46	2,19	3,15	1,67	1,89
7	3,09	0,49	6,31	3,20	0,60	5,33	3,20	0,84	3,81	3,20	1,14	2,81	2,95	1,22	2,42

### WH-UDZ05KE5

Tamb	HC	IP	COP	HC	IP	COP	HC	IP	COP	HC	IP	COP	HC	IP	COP
LWC	25	25	25	35	35	35	45	45	45	55	55	55	60	60	60
-20	—	—	—	4,05	1,95	2,08	3,76	2,20	1,71	3,39	2,48	1,37	—	—	—
-15	—	—	—	5,00	2,11	2,37	4,75	2,49	1,91	4,30	2,61	1,65	—	—	—
-7	—	—	—	5,00	1,79	2,79	5,00	2,14	2,34	5,00	2,65	1,89	4,68	2,71	1,73
2	—	—	—	5,00	1,40	3,57	5,00	1,79	2,79	5,00	2,18	2,29	4,80	2,40	2,00
7	—	—	—	5,00	0,98	5,10	5,00	1,31	3,82	5,00	1,65	3,03	4,58	1,90	2,41

### WH-UDZ07KE5

Tamb	HC	IP	COP	HC	IP	COP	HC	IP	COP	HC	IP	COP	HC	IP	COP
LWC	25	25	25	35	35	35	45	45	45	55	55	55	60	60	60
-20	—	—	—	4,45	2,12	2,10	4,23	2,48	1,71	3,90	2,85	1,37	—	—	—
-15	—	—	—	5,60	2,38	2,35	5,30	2,78	1,91	5,00	3,20	1,56	—	—	—
-7	—	—	—	5,75	1,95	2,95	5,65	2,30	2,46	5,35	2,70	1,98	4,98	2,90	1,72
2	—	—	—	6,85	2,00	3,43	6,75	2,40	2,81	6,25	2,80	2,23	6,18	2,91	2,12
7	—	—	—	7,00	1,44	4,86	7,00	1,92	3,65	7,00	2,40	2,92	6,86	2,73	2,51

### WH-UDZ09KE5

Tamb	HC	IP	COP	HC	IP	COP	HC	IP	COP	HC	IP	COP	HC	IP	COP
LWC	25	25	25	35	35	35	45	45	45	55	55	55	60	60	60
-20	—	—	—	4,95	2,43	2,04	4,58	2,70	1,70	4,04	3,00	1,35	—	—	—
-15	—	—	—	7,40	3,20	2,31	6,45	3,28	1,97	5,40	3,42	1,58	—	—	—
-7	—	—	—	6,25	2,20	2,84	6,10	2,68	2,28	5,90	3,06	1,93	5,65	3,24	1,74
2	—	—	—	7,00	2,06	3,40	6,85	2,50	2,74	6,30	2,89	2,18	7,26	3,31	2,19
7	—	—	—	9,00	1,98	4,55	9,00	2,58	3,49	8,90	3,04	2,93	8,60	3,42	2,51

### WH-UDZ12KE5

Tamb	HC	IP	COP	HC	IP	COP	HC	IP	COP	HC	IP	COP	HC	IP	COP
LWC	25	25	25	35	35	35	45	45	45	55	55	55	60	60	60
-20	—	—	—	8,80	4,42	1,99	8,00	4,95	1,62	7,00	5,65	1,24	—	—	—
-15	—	—	—	9,10	3,70	2,46	8,20	4,00	2,05	7,20	4,21	1,71	—	—	—
-7	—	—	—	10,10	3,69	2,74	9,30	4,29	2,17	8,40	4,27	1,97	7,30	4,40	1,66
2	—	—	—	11,50	3,34	3,44	10,70	3,78	2,83	9,20	4,09	2,25	8,20	4,40	1,86
7	—	—	—	12,10	2,53	4,78	12,00	3,38	3,55	12,00	4,06	2,96	10,20	4,26	2,39

Tamb: Ambient Temperature [°C]. LWC: Leaving Water Condenser Temperature [°C]. HC: Heating Capacity (kW). CC: Cooling Capacity (kW). IP: Input Power (kW). This data is measured by Panasonic in accordance with EN 14511-2 standard. This data is for reference purpose only, and does not guarantee the performance.

### Aquarea High Performance Bi-bloc K Series. Single phase · R32

#### WH-UDZ03KE5

Tamb	CC	IP	EER	CC	IP	EER	CC	IP	EER
LWC	7	7	7	14	14	14	18	18	18
16	3,56	0,57	6,25	4,32	0,55	7,85	3,47	0,41	8,46
25	3,29	0,73	4,51	4,06	0,72	5,64	3,27	0,52	6,29
35	3,20	0,91	3,52	3,56	0,93	3,83	3,20	0,68	4,71
43	2,68	1,06	2,53	3,34	1,09	3,06	2,79	0,82	3,40

#### WH-UDZ05KE5

Tamb	CC	IP	EER	CC	IP	EER	CC	IP	EER
LWC	7	7	7	14	14	14	18	18	18
25	5,47	1,37	3,99	6,62	1,39	4,76	5,54	0,80	6,93
35	5,00	1,64	3,05	6,69	1,76	3,80	5,00	1,02	4,90
43	4,18	1,83	2,28	5,54	1,84	3,01	4,45	1,27	3,50

#### WH-UDZ07KE5

Tamb	CC	IP	EER	CC	IP	EER	CC	IP	EER
LWC	7	7	7	14	14	14	18	18	18
25	6,32	1,72	3,67	8,16	1,93	4,23	6,63	1,12	5,92
35	6,70	2,21	3,03	8,19	2,42	3,38	6,70	1,42	4,72
43	5,72	2,62	2,18	7,47	2,80	2,67	6,15	1,78	3,46

#### WH-UDZ09KE5

Tamb	CC	IP	EER	CC	IP	EER	CC	IP	EER
LWC	7	7	7	14	14	14	18	18	18
25	8,31	2,50	3,32	10,43	2,67	3,91	8,85	1,72	5,15
35	8,20	3,02	2,72	10,28	3,25	3,16	9,00	2,15	4,19
43	5,00	2,15	2,33	6,38	2,15	2,97	7,02	2,14	3,28

#### WH-UDZ12KE5

Tamb	CC	IP	EER	CC	IP	EER	CC	IP	EER
LWC	7	7	7	14	14	14	18	18	18
25	10,20	3,62	2,82	12,00	3,70	3,24	10,80	2,53	4,27
35	10,70	4,00	2,68	10,70	4,54	2,36	10,70	2,73	3,92
43	6,10	3,55	1,72	7,20	3,56	2,02	8,00	3,55	2,25

Tamb: Ambient Temperature (°C). LWC: Leaving Water Condenser Temperature (°C). HC: Heating Capacity (kW). CC: Cooling Capacity (kW). IP: Input Power (kW).  
This data is measured by Panasonic in accordance with EN 14511-2 standard. This data is for reference purpose only, and does not guarantee the performance.

### Aquarea EcoFlex. Single phase · R32

#### CU-2WZ71YBE5

Tamb	HC	IP	COP	HC	IP	COP	HC	IP	COP	HC	IP	COP
LWC	25	25	25	35	35	35	45	45	45	55	55	55
-15	4,85	2,15	2,26	4,75	2,28	2,08	4,65	2,44	1,91	4,50	3,20	1,41
-7	5,40	1,70	3,18	5,60	1,97	2,84	5,60	2,40	2,33	5,30	2,78	1,91
2	6,50	1,77	3,67	6,70	2,06	3,25	6,60	2,45	2,69	6,00	2,89	2,08
7	8,16	1,63	5,01	8,00	1,90	4,21	8,00	2,30	3,48	8,00	2,85	2,81
12	8,22	1,28	6,42	8,00	1,52	5,26	8,00	2,00	4,00	8,00	2,60	3,08

# Features explained

## Energy saving.



**NATURAL REFRIGERANT R290 WITH GWP 0,02.** Natural refrigerant R290 has low Global Warming Potential (GWP) of just 0,02, helping reduce CO<sub>2</sub> emissions and environmental impact.



**REFRIGERANT R32.** Our heat pumps containing R32 refrigerant show a drastic reduction in the value of Global Warming Potential (GWP).



**BETTER EFFICIENCY AND VALUE FOR MEDIUM TEMPERATURE APPLICATIONS.** Energy efficiency class up to A++ in a scale from A+++ to D.



**BETTER EFFICIENCY AND VALUE FOR LOW TEMPERATURE APPLICATIONS.** Energy efficiency class up to A+++ in a scale from A+++ to D.



**BETTER EFFICIENCY AND VALUE FOR DOMESTIC HOT WATER.** Energy efficiency class up to A+ in a scale from A+ to F.



**INVERTER PLUS SYSTEM.** Inverter Plus system classification highlights Panasonic's highest performing systems.



**A CLASS WATER PUMP.** Aquarea are built-in with A class energy efficiency water pump. High-efficiency circulating the water in the heating installation.



**ERP 2018.** Compliant following COMMISSION REGULATION (EU) No2016/2281.



**EC MOTOR GREEN VENTILATION.** Range of fan coils with improved efficiency and optional EC fan motors.

## High performance and indoor air quality.



**AQUAREA HIGH PERFORMANCE FOR LOW CONSUMPTION HOUSES.** From 3 to 16 kW. For a house with low temperature radiators or under-floor heating, our high performance Aquarea HP is a good solution. \*COP of 5,33 for 3 kW K series.



**DHW.** With Aquarea Heat Pumps, DHW can be produced efficiently, achieving high DHW COP of 3,6 with the L Series All in One indoor unit.



**75 °C OUTPUT WATER.** Reaches water outlet temperature up to 75 °C for L and M Series.



**AQUAREA T-CAP FOR EXTREMELY LOW TEMPERATURES.** From 9 to 16 kW. It can work at outdoor temperatures as low as -28 °C and maintain the rated capacity down to -15 °C at 55 °C water flow.



**DOWN TO -20 °C IN HEATING MODE.** The heat pumps operate in heating mode with an outside temperature down to -20 °C.



**65 °C OUTPUT WATER.** Reaches water outlet temperature up to 65 °C.



**WATER FILTER WITH MAGNET.** Easy access and fast clip technology for J Series onwards. Water filter only for H Series.



**WATER FLOW SENSOR.** Included on H Series onwards.



**5 YEARS COMPRESSOR WARRANTY.** We guarantee the outdoor unit compressors in the entire range for five years.

## High connectivity.



**RENOVATION.** Our Aquarea Heat Pumps can be connected to an existing or new boiler for optimum comfort even at very low outdoor temperatures.



**INTERNET CONTROL.** The Panasonic Comfort Cloud App allows users to conveniently manage and monitor Panasonic residential heat pumps from a mobile device, anytime, anywhere.



**SOLAR KIT.** For even greater efficiency, Aquarea Heat Pumps can be connected to photovoltaic solar panels with the optional PCB.



**BMS CONNECTIVITY.** Aquarea Heat Pumps offer seamless integration into a Building Management System (BMS) using an optional gateway.



**ADVANCED CONTROL.** Remote controller with full dotted 3,5" wide back light screen. Menu with 17 available languages easy to use for installer and user. Included on H Series onwards.



Aquarea H and J Series heat pumps in combination with the optional PCB CZ-NSP4 hold the SG Ready Label (Smart Grid Ready Label), given by Bundesverband Wärmepumpe (German Heat Pump Association). This Label shows the real capacity of Aquarea to be connected in an intelligent grid control. MCS Certificate number: MCS HP0086\*. Keymark: Check all our certified heat pumps on: [www.heatpumpkeymark.com](http://www.heatpumpkeymark.com). Passive House Institute: Certified models can be checked in <https://database.passivehouse.com>.

\*Not all products certified. As the certification process is on-going and the list of certified products constantly changing, please check for latest details on the official websites.

**Warning on quality of water and groundwater use:** This product is designed to comply with the European drinking water standard (EU) 2020/2184. The lifespan of the product is not guaranteed in the case of the use of groundwater, such as spring water or well water, the use of tap water when salt or other impurities are contained, nor in areas of acidic water quality. Maintenance and warranty costs related to these cases are the customer's responsibility.

## Examples of installations

**Aquarea Split Bi-bloc: Bivalent with buffer tank and mixing valve**

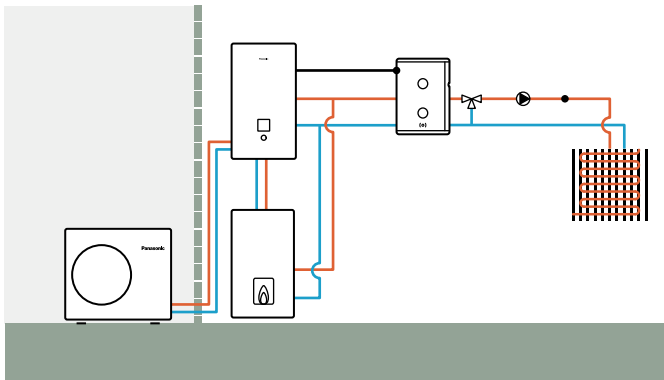

**Aquarea Split Bi-bloc: Buffer tank with solar and mixing valve**

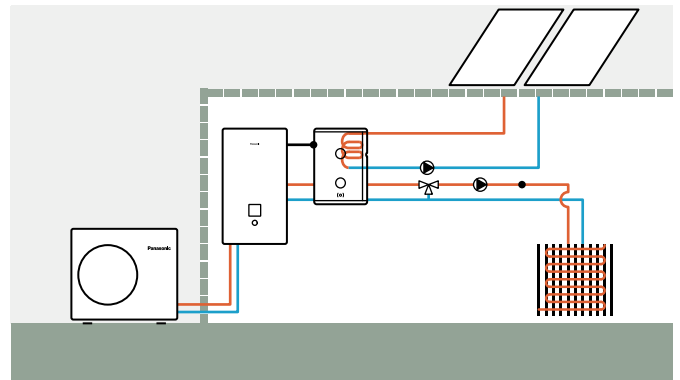

**Aquarea Hydraulic Mono-bloc: 2 zones with external kit without buffer tank**

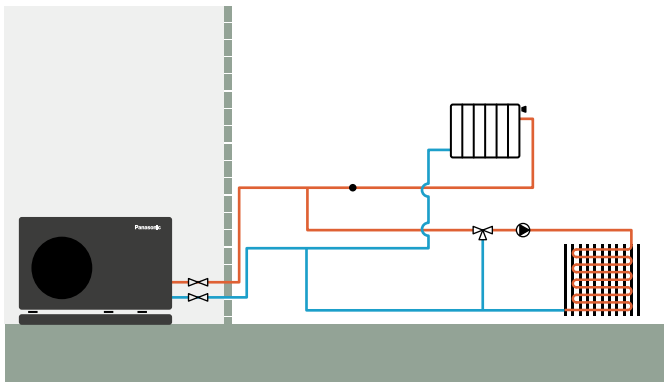

**Aquarea Hydraulic Bi-bloc: 2 zones with external kit, buffer tank and swimming pool**

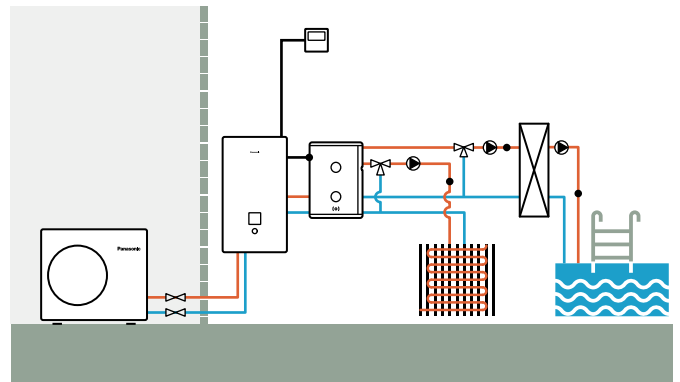

**Aquarea Hydraulic All in One: 2 zones with external kit, without buffer tank**

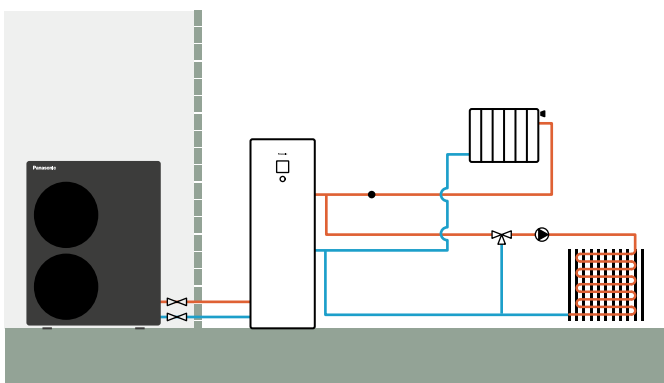

**Aquarea Hydraulic All in One 2 zones: 2 zones built-in, without buffer tank**

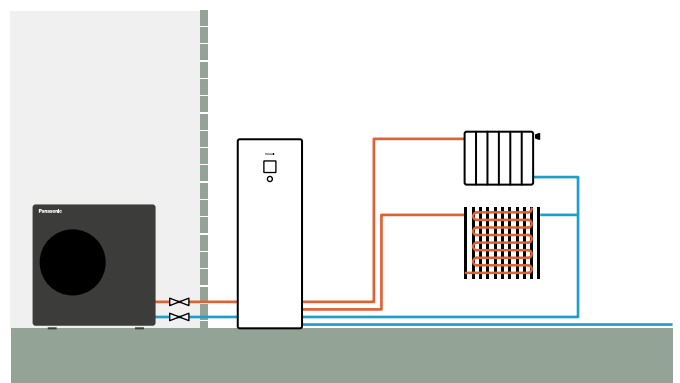

### Hydraulic scheme generator.

The Aquarea Hydraulic Scheme Generator (HSG) allows users to select a hydraulic schematic according to their installation requirements. This will be accompanied by the relevant electrical connection schematic and component list.

Available on PRO Club [www.panasonicproclub.com](http://www.panasonicproclub.com).

