



Commercial ventilation

Panasonic ventilation solutions for better air quality, maximum savings, easy integration.

ABOUT

Air handling unit kit	→ 401
AHU connection kit PAH3M-1 for PACi NX	→ 403
AHU connection kit MAH4M for ECOi 2-Pipe	→ 405
AHU connection kit MAH3M for 3-Pipe ECOi EX MF3 Series	→ 411
Advanced energy recovery ventilation - ZY Series	→ 413
Energy recovery ventilation with DX coil - HRPT Series for VRF	→ 415
Electric air curtains	→ 417
Ceiling mounted air-e nanoe X Generator	→ 420
High pressure duct and 100% fresh air duct function	→ 421
Residential ventilation	
Heat recovery ventilation unit	→ 423
Aquarea Vent - Counter flow ventilation	→ 425

PRODUCT SPECIFICATIONS

AHU connection kit MAH4M for ECOi 2-Pipe · R32	→ 407
AHU connection kit MAH4M for ECOi 2-Pipe · R410A	→ 409
AHU connection kit MAH3M for 3-Pipe ECOi EX MF3 Series · R410A	→ 412
Advanced energy recovery ventilation - ZY Series	→ 414
Energy recovery ventilation with DX coil - HRPT Series · R32 / R410A	→ 416
Air curtain with DX coil, connected to PACi NX	→ 417
Air curtain with DX coil, connected to ECOi 2-Pipe	→ 418
Electric air curtain	→ 419
Ceiling mounted air-e nanoe X Generator	→ 420
E2 type high static pressure hide-away · R410A	→ 422
Heat recovery ventilation unit	→ 424
Aquarea Vent - Counter flow ventilation units	→ 426

Air handling unit kit

AHU connection kits connect outdoor units to air handling systems.

Combines air conditioning and fresh air in just one solution. Application: Hotels, offices, server rooms or all large buildings where air quality control, such as humidity control and fresh air, is needed.



AHU connection kit PAH3M-1 for PACi NX (2,5 - 22,0 kW*).

- Durable metal casing (IP 65) allows external installation
- 0-10 V demand control
- CONEX Bluetooth® control built-in (CZ-RTC6BL)
- Panasonic H&C Control App via Bluetooth®
- Easy integration to BMS

*Nominal cooling capacity.

**AHU connection kit MAH4M for ECOi 2-Pipe (12,0 - 134,0 kW*).**

- Space-saving compact casing
- 0-10 V demand control
- Built-in controller for daily functions and service levels
- Direct Modbus communication without an additional interface
- Easy integration to BMS
- Accurate control with a pressure transducer

*Nominal cooling capacity.

**AHU connection kit MAH3M for 3-Pipe ECOi EX MF3 Series (14,0 - 28,0 kW*).**

- Durable metal casing (IP 65) allows external installation
- 0-10 V demand control
- CONEX Bluetooth® control built-in (CZ-RTC6BL)
- Panasonic H&C Control App via Bluetooth®
- Easy integration to BMS

*Nominal cooling capacity.

**AHU connection kit line-up.**

AHU connection kit	Reference	Casing	Controller	0-10 V demand control	Compatible outdoor units
PAH3M-1	PAW-280PAH3M-1	Durable metal casing (IP 65)	CONEX Bluetooth® control (CZ-RTC6BL)	Yes	PACi NX
MAH4M	PAW-P+100MAH4M	Durable metal casing (IP 65)	Built-in c.pCO controller	Yes	Mini ECOi and ECOi EX 2-Pipe
MAH3M	PAW-160MAH3M PAW-280MAH3M	Durable metal casing (IP 65)	CONEX Bluetooth® control (CZ-RTC6BL)	Yes	ECOi EX 3-Pipe MF3

AHU connection kit PAH3M-1 for PACi NX

Compatible with R32 or R410A outdoor units.

The Panasonic AHU connection kits offer a wealth of connectivity possibilities, integrating easily into many systems.

Besides the advantages in terms of indoor air quality, air conditioning offers also an energy saving potential. For example, uncontrolled ventilation through open windows leads to large amounts of heat being lost to the outside during the heating season or gained from the outside during the cooling season. Whereas, combining heat recovery with air conditioning can allow for a high level of comfort whilst reducing the overall operating costs of running air conditioning alone. The larger area of the comfort range, the better the energy saving opportunities.

System example with AHU connection kit PAH3M-1 and PACi NX outdoor unit

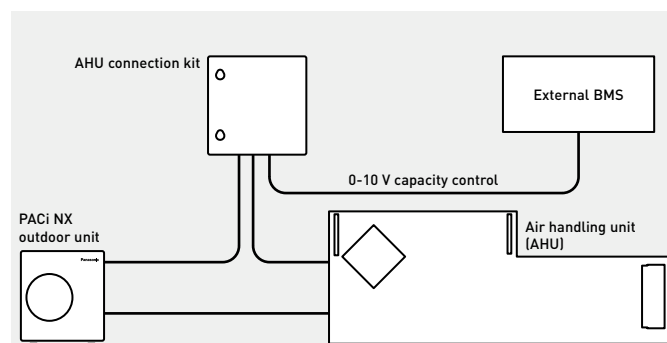

Demand control on the outdoor unit managed by external 0-10 V signal.

- AHU connection kit contains: IP 65 box with PCBs and terminal connections mounted inside, expansion valve and sensors
- Heat exchanger, fan and fan motor to be mounted in the AHU itself are field supplied

Main components of mechanical ventilation systems

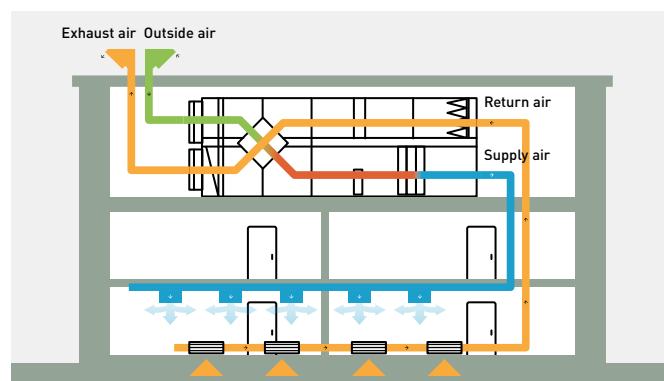

- Air handling unit (AHU)
- Air ducts
- Air distribution elements

Control options

Control option 1.

- The system's control is simple: control of actual suction temperature vs. set point
- Control works in the same way as that of any indoor unit
- Fan signal issued by the PCB (OFF while defrosting, for instance)

Control option 2.

- System control by a 0-10 V control working from an external BMS that manages the set point for temperature or capacity. Enhances efficiency by adjusting capacity and enhances comfort as well
- All signals as standard

0-10 V control

With the 0-10 V demand control the capacity of the outdoor unit can be controlled by 20 steps.

Input voltage* (V)	0	1,0	1,5	2,0	2,5	3,0	3,5	4,0	4,5	5,0	5,5	6,0	6,5	7,0	7,5	8,0	8,5	9,0	9,5
Demand [% of nominal current]	No cut ¹⁾	40	45	50	55	60	65	70	75	80	85	90	95	100	105	110	115	120	No limit / Full capacity ²⁾
Indoor unit start / stop	Stop ¹⁾													Start					

1) No cut / stop: AHU system / indoor unit is completely switched OFF.

2) No limit: No restrictions applied by BMS to AHU system / indoor unit performance (equivalent to "full-load operation" of AHU system / indoor unit).

AHU connection kit.

PCB, power trans, terminal block.



Thermistor x2 (refrigerant: E1, E2).



Thermistor (air: TA; 1 sensor).



Wired remote controller. CZ-RTC6BL.



Optional controller.

Timer remote controller. CZ-RTC5B.





PACi

AHU connection kit PAH3M-1 for PACi NX

CONEX



CONEX Bluetooth® control built-in. CZ-RTC6BL



PAW-280PAH3M-1			2,5 kW	3,6 kW	5,0 kW	6,0 kW	7,5 kW	10,0 kW	12,5 kW	14,0 kW	20,0 kW	25,0 kW
Dimension	HxWxD	mm	500 x 400 x 150	500 x 400 x 150	500 x 400 x 150	500 x 400 x 150	500 x 400 x 150	500 x 400 x 150	500 x 400 x 150	500 x 400 x 150	500 x 400 x 150	500 x 400 x 150
Net weight		kg	11,5	11,5	11,5	11,5	11,5	11,5	11,5	11,5	11,5	11,5
Piping diameter	Liquid	Inch (mm)	1/4 (6,35)	1/4 (6,35)	1/4 (6,35)	3/8 (9,52)	3/8 (9,52)	3/8 (9,52)	3/8 (9,52)	1/2 (12,70)	1/2 (12,70)	1/2 (12,70)
	Gas	Inch (mm)	1/2 (12,70)	1/2 (12,70)	1/2 (12,70)	5/8 (15,88)	5/8 (15,88)	5/8 (15,88)	5/8 (15,88)	7/8 (22,22)	7/8 (22,22)	7/8 (22,22)
Intake temperature of AHU connection kit	Cool Min~Max	°C DB	18~32	18~32	18~32	18~32	18~32	18~32	18~32	18~32	18~32	18~32
	Cool Min~Max	°C WB	14~25	14~25	14~25	14~25	14~25	14~25	14~25	14~25	—	—
	Heat Min~Max	°C	16~30	16~30	16~30	16~30	16~30	16~30	16~30	16~30	16~30	16~30

With PACi NX Elite												
Cooling capacity		kW	—	3,6	5,0	6,0	7,1	10,0	12,5	14,0	19,0	22,0
Heating capacity		kW	—	4,0	5,6	7,0	8,0	11,2	14,0	16,0	22,4	24,0
Air flow	Min / Max	m³/h	—	540/870	630/990	780/1320	780/1320	900/2160	1140/2280	1200/2400	2160/8000	2160/9000
Pipe length range		m	—	3~40	3~40	3~40	5~60	5~100	5~100	5~100	5~100	5~100
Elevation difference (in / out)	Max	m	—	30	30	30	30	30	30	30	30	30
Ambient temperature of outdoor unit	Cool Min~Max	°C	—	-15~+46	-15~+46	-15~+46	-15~+46	-20~+48	-20~+48	-20~+48	-15~+52	-15~+52
	Heat Min~Max	°C	—	-20~+24	-20~+24	-20~+24	-20~+24	-20~+24	-20~+24	-20~+24	-20~+35	-20~+35

With PACi NX Standard												
Cooling capacity		kW	2,5	3,6	5,0	6,0	7,1	10,0	12,5	14,0	—	—
Heating capacity		kW	3,2	4,0	5,0	6,0	7,1	10,0	12,5	14,0	—	—
Air flow	Min / Max	m³/h	360 / 570	540/870	630/990	780/1320	780/1320	900/2160	1140/2280	1200/2400	—	—
Pipe length range		m	3~15	3~15	3~20	3~40	3~40	5~50	5~50	5~50	—	—
Elevation difference (in / out)	Max	m	15	30	30	30	30	30	30	30	—	—
Ambient temperature of outdoor unit	Cool Min~Max	°C	-10~+43	-10~+43	-10~+43	-10~+43	-10~+43	-10~+43	-10~+43	-10~+43	—	—
	Heat Min~Max	°C	-15~+24	-15~+24	-15~+24	-15~+24	-15~+24	-15~+24	-15~+24	-15~+24	-15~+24	—

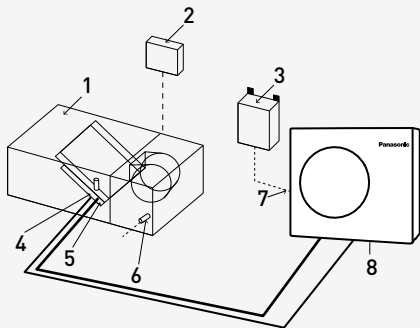

System and regulations. System overview.

- 1 | AHU equipment (field supplied)
- 2 | AHU system controller (field supplied)
- 3 | AHU connection kit controller box (with control PCB)
- 4 | Thermistor for gas pipe (E2)
- 5 | Thermistor for liquid pipe (E1)
- 6 | Thermistor for suction air
- 7 | Inter-unit wiring
- 8 | Outdoor unit

Outdoor unit	Air flow volume m³/min																																								
	360	510	540	570	630	720	780	870	900	960	990	1080	1170	1200	1320	1450	1500	1600	1740	1800	1900	2000	2160	2280	2300	2400	2520	2610	2640	2800	2970	3000	3480	3600							
PACi NX Elite																																									
U-36PZH3E5																																									
U-50PZH3E5																																									
U-60PZH3E5																																									
U-71PZH4E5/8																																									
U-100PZH4E5/8																																									
U-125PZH4E5/8																																									
U-140PZH4E5/8																																									
PACi NX Standard																																									
U-25PZ3E5																																									
U-36PZ3E5																																									
U-50PZ3E5																																									
U-60PZ3E5																																									
U-71PZ3E5																																									
U-100PZ3E5/8																																									
U-125PZ3E5/8																																									
U-140PZ3E5/8																																									

Maximum allowed air volume flow under "Standard conditions". Higher maximum allowed air volume flow under "Special conditions" 1). Maximum allowed air intake temperature at AHU DX coil heat exchanger in cooling mode is restricted to 30 °C DB.

1) Using an AHU unit with a higher maximum allowed air volume flow is subject to a restriction of the "Air intake temperature" to 30 °C DB (instead of 32 °C WB under standard conditions).

AHU connection kit MAH4M for ECOi 2-Pipe



System example with AHU connection kit MAH4M and Mini ECOi outdoor unit.

- AHU connection kit in an IP 65 casing, contains PCBs and terminal connections mounted inside
- Select the size of the expansion valve pack based on the capacity
- Direct Modbus communication with a built-in Modbus S-Link interface
- The heat exchanger, fan, and fan motor to be mounted in the AHU are field-supplied

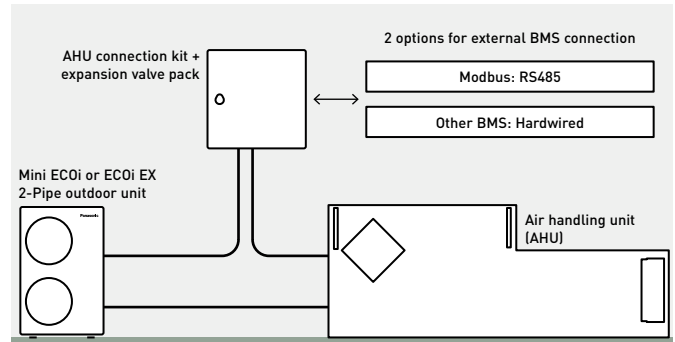

Demand control on the outdoor unit managed by external 0-10 V signal.

0-10 V control

With 0-10 V demand control, the outdoor unit capacity can be adjusted in each 5% demand step. Temperature set control (default discharge temperature control) is also available in each 0,5 K step.

Input voltage* [V]	0	1,0	1,5	2,0	2,5	3,0	3,5	4,0	4,5	5,0	5,5	6,0	6,5	7,0	7,5	8,0	8,5	9,0	9,5
Demand [% of nominal current]	No cut ¹⁾	40	45	50	55	60	65	70	75	80	85	90	95	100	105	110	115	120	No limit / Full capacity ²⁾
Indoor unit start / stop	Stop ¹⁾																		Start

1) No cut / stop: AHU system / indoor unit is completely switched OFF.

2) No limit: No restrictions applied by BMS to AHU system / indoor unit performance (equivalent to "full-load operation" of AHU system / indoor unit).

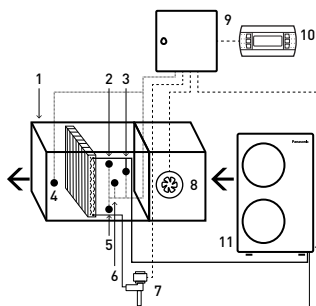

System and regulations. System overview.

- 1 | AHU Unit equipment (field supplied)
- 2 | Thermistor for gas pipe (E3)
- 3 | Pressure transducer
- 4 | Thermistor for discharge air (BL)
- 5 | Thermistor for liquid pipe (E1)
- 6 | Thermistor for suction air (TA)
- 7 | Expansion valve (accessorie part)
- 8 | Fan (field supplied)
- 9 | AHU connection kit controller box
- 10 | Optional remote controller
- 11 | Outdoor unit Mini ECOi and 2-Pipe ECOi EX

Optional parts for AHU connection kit MAH4M.

EEV (Electric expansion valve) pack.

EEV controls refrigerant circuit superheat (or subcooling), directly managed by the c.pCO mini controller. Different sizes based on capacity.

EEV pack 1: includes one expansion valve (≤ 16,0 kW [R32 / R410A] , one unipolar stator, and two bidirectional filters	PAW-P+116EEVPACK
EEV pack 2: includes one expansion valve (≤ 33,0 kW [R32 / R410A] , one unipolar stator, and two bidirectional filters	PAW-P+133EEVPACK
EEV pack 3: includes one expansion valve (≤ 45,0 kW [R32 / R410A] , one unipolar stator, and two bidirectional filters	PAW-P+145EEVPACK
EEV pack 4: includes one expansion valve (≤ 61,5 kW [R32 / R410A] , one unipolar stator, and two bidirectional filters	PAW-P+156EEVPACK
EEV pack 5: includes one expansion valve (≤ 96,0 kW [R32 / R410A] , one unipolar stator, and two bidirectional filters	PAW-P+174EEVPACK

*Example image.

Remote control pack.

PAW-P+100PGNEPACK.
Graphic display remote control, managing both icons and international fonts.



AHU connection kit sensor pack.

PAW-P+102SENSPACK.
AHU connection kit sensor pack 1 (2 pcs of SENSOR PT1000 HT IP67 -50/250 CABLE 6 m PCK).



AHU connection kit MAH4M for ECOi 2-Pipe - R32

- Space-saving compact casing
- Direct Modbus communication without the need for an additional interface
- Accurate control with a pressure transducer
- PAW-P+100MAH4M (H x W x D): 300 x 400 x 150 mm, 11 kg



Built-in controller.



AHU kit PAW-P+100MAH4M		4 HP	5 HP	6 HP	8 HP LZ2	8 HP MZ1	10 HP LZ2	10 HP MZ1	12 HP	
AHU connection kit		116EEVPACK	116EEVPACK	116EEVPACK	116EEVPACK	116EEVPACK	133EEVPACK	133EEVPACK	133EEVPACK	
Outdoor unit		U-4LZ2E5(8)	U-5LZ2E5(8)	U-6LZ2E5(8)	U-8LZ2E8	U-8MZ1E8	U-10LZ2E8	U-8MZ1E8	U-10MZ1E8	
Nominal cooling capacity	kW	12,0	14,0	16,0	22,4	22,4	28,0	28,0	33,5	
Nominal heating capacity	kW	12,5	16,0	17,0	25,0	25,0	28,0	31,5	37,5	
Minimum cooling continuous ¹⁾	kW	6,6	6,6	6,6	6,6	6,6	10,7	10,7	10,7	
Minimum heating continuous ²⁾	kW	7,4	7,4	7,4	7,4	7,4	12,1	12,1	12,1	
Air flow volume	Min	m ³ /h	1100	1100	1100	1700	1700	2000	2000	2000
	Max	m ³ /h	4000	5000	5000	8000	10000	8600	10000	10000
AHU DX coil heat exchanger volume	Min	dm ³	1,5	1,5	1,5	2,0	2,0	2,0	2,0	2,0
	Max	dm ³	5,5	6,3	7,0	7,0	8,5	7,0	10,0	12,0
Piping length	Min / Max	m	10/60	10/60	10/60	10/70	10/100	10/70	10/100	10/100
Maximum branch pipe length	m	12	12	12	12	12	12	12	12	
Maximum pipe length difference after 1st joint	m	10	10	10	10	10	10	10	10	
Maximum elevation difference (in / out)	m	10	10	10	10	10	10	10	10	
Piping connections EEV	mm	8	8	8	10	10	10	10	10	
Piping diameter branch pipe	Liquid	Inch (mm)	3/8(9,52)	3/8(9,52)	3/8(9,52)	3/8(9,52)	3/8(9,52)	3/8(9,52)	3/8(9,52)	3/8(9,52)
	Gas	Inch (mm)	5/8(15,88)	5/8(15,88)	5/8(15,88)	3/4(19,05)	3/4(19,05)	7/8(22,22)	3/4(19,05)	7/8(22,22)
On coil temperature	Cool Min - Max	°C DB	12/32	12/32	12/32	12/32	12/32	12/32	12/32	12/32
		°C WB	8~25	8~25	8~25	8~25	8~25	8~25	8~25	8~25
	Heat Min - Max	°C DB	0~32 ³⁾	0~32 ³⁾	0~32 ³⁾	0~32 ³⁾	0~32 ³⁾	0~32 ³⁾	0~32 ³⁾	0~32 ³⁾
Outdoor temperature	Cool Min - Max	°C DB	-10~52	-10~52	-10~52	-10~52	-10~50	-10~52	-10~50	-10~50
	Heat Min - Max	°C WB	-20~18	-20~18	-20~18	-20~18	-25~24 ⁴⁾	-20~18	-25~24 ⁴⁾	-25~24 ⁴⁾

1) At rated condition with 35 °C DB outdoor and 27 °C DB / 19 °C WB on coil. 2) At rated condition with 7 °C DB / 6 °C WB outdoor and 20 °C DB on coil. 3) In case of on coil temperature of 5 °C or below and of 31 °C and above air flow would be restricted. 4) In case of on coil temperature > +18 °C WB in heating mode, intermittent operation could happen.

Technical focus

- Maximum capacity / system: 48 HP (134 kW*)
- Selectable expansion valve packs depending on the capacity
- DC 12 V outlet available without optional interface
- Maximum elevation difference indoor/outdoor unit: 10 m
- Elevation difference (indoor unit / indoor unit): 4 m
- In / out connection capacity ratio: 50~100%
- Maximum number of AHU connection kits: 1 unit
- Outdoor temperature range in heating: -20~+15 °C
- Available temperature range for the suction air at AHU connection kit: cool: +18~+32 °C / heat: +16~+30 °C
- The system's set temperature can be selected either as the default setting discharge air temperature (supply room temperature) or the suction air set temperature (or room return air temperature)
- Accurate control with a pressure transducer
- Direct Modbus communication with a built-in Modbus S-Link interface
- Various technical parameters available with Modbus
- SG Ready fulfilled. Demand input can be set Thermostat OFF or 40~200% by the user
- Defrost operation signal, compressor status ON / OFF output
- Display an error message concerning drain water overflow
- Connectable with S-Link system. Special care for electrical noise may be necessary depending on the on-site system
- Fan control signal output to manage the air flow (ON / OFF)
- Alarm status monitoring output

*Nominal cooling capacity.

Accessories	
PAW-P+102SENSPACK	AHU connection kit sensor pack 1 (2 pcs of SENSOR PT1000 HT IP67 -50/250 CABLE 6 m PCK)
PAW-P+116EEVPACK	EEV pack 1 (1 pc of expansion valve ≤ 16,0 kW (R32 / R410A) and 1 pc of UNIPOLAR stator and filter strainers)
PAW-P+133EEVPACK	EEV pack 2 (1 pc of expansion valve ≤ 33,0 kW (R32 / R410A) and 1 pc of UNIPOLAR stator and filter strainers)
PAW-P+145EEVPACK	EEV pack 3 (1 pc of expansion valve ≤ 45,0 kW (R32 / R410A) and 1 pc of UNIPOLAR stator and filter strainers)

Accessories	
PAW-P+156EEVPACK	EEV pack 4 (1 pc of expansion valve ≤ 61,5 kW (R32 / R410A) and 1 pc of UNIPOLAR stator and filter strainers)
PAW-P+174EEVPACK	EEV pack 5 (1 pc of expansion valve ≤ 96,0 kW (R32 / R410A) and 1 pc of UNIPOLAR stator and filter strainers)
PAW-P+100PGNEPACK	Remote control pack (1 pc of PGNE 132 x 64 mm, mounting panel and 1 pc of cable L= 1,5 m, telephone connectors)



R32

AHU connection kit MAH4M for ECOi 2-Pipe combination from 16 to 48 HP - R32

ECO i EX ECO i



Built-in controller.

AHU kit PAW-P+100MAH4M			16 HP	18 HP	20 HP	22 HP	24 HP	26 HP	28 HP	30 HP
AHU connection kit			145EEVPACK	145EEVPACK	145EEVPACK	145EEVPACK	156EEVPACK	156EEVPACK	156EEVPACK	174EEVPACK
Outdoor unit			2×U-8MZ1E8	U-8MZ1E8 + U-10MZ1E8	2×U-10MZ1E8	U-10MZ1E8 + U-12MZ1E8	2×U-12MZ1E8	2×U-8MZ1E8 + U-10MZ1E8	U-8MZ1E8 + 2×U-10MZ1E8	3×U-10MZ1E8
Multi combination			8+8	8+10	10+10	10+12	12+12	8+8+10	8+10+10	10+10+10
Nominal cooling capacity	kW		44,8	50,4	56,0	61,5	67,0	72,8	78,4	84,0
Nominal heating capacity	kW		50,0	56,5	63,0	69,0	75,0	81,5	88,0	94,5
Minimum cooling continuous ¹⁾	kW		15,9	15,9	15,9	15,9	23,3	23,3	23,3	32,8
Minimum heating continuous ²⁾	kW		18,0	18,0	18,0	18,0	26,3	26,3	26,3	37,1
Air flow volume	Min	m ³ /h	3400	3700	4000	4000	4000	5400	5700	6000
	Max	m ³ /h	16000	20000	20000	20000	20000	24000	26000	30000
AHU DX coil heat exchanger volume	Min	dm ³	4,0	4,0	4,0	4,0	4,0	6,0	6,0	6,0
	Max	dm ³	15,0	18,0	20,0	22,0	24,0	27,0	28,5	30,0
Piping length	Min / Max	m	10/100	10/100	10/100	10/100	10/100	10/100	10/100	10/100
Maximum branch pipe length	m		12	12	12	12	12	12	12	12
Maximum pipe length difference after 1st joint	m		10	10	10	10	10	10	10	10
Maximum elevation difference (in / out)	m		10	10	10	10	10	10	10	10
Piping connections EEV	mm		10	10	10	10	16	16	16	7/8"
Piping diameter branch pipe	Liquid	Inch (mm)	1/2(12,70)	1/2(12,70)	1/2(12,70)	1/2(12,70)	1/2(12,70)	1/2(12,70)	1/2(12,70)	5/8(15,88)
	Gas	Inch (mm)	1 1/8(28,58)	1 1/8(28,58)	1 1/8(28,58)	1 1/8(28,58)	1 1/8(28,58)	1 1/8(28,58)	1 1/8(28,58)	1 3/8(34,98)
On coil temperature	Cool Min ~ Max	°C DB	12~32	12~32	12~32	12~32	12~32	12~32	12~32	12~32
		°C WB	8~25	8~25	8~25	8~25	8~25	8~25	8~25	8~25
	Heat Min ~ Max	°C DB	0~32 ³⁾	0~32 ³⁾	0~32 ³⁾	0~32 ³⁾	0~32 ³⁾	0~32 ³⁾	0~32 ³⁾	0~32 ³⁾
Outdoor temperature	Cool Min ~ Max	°C DB	-10~50	-10~50	-10~50	-10~50	-10~50	-10~50	-10~50	-10~50
	Heat Min ~ Max	°C WB	-25~24 ⁴⁾	-25~24 ⁴⁾	-25~24 ⁴⁾	-25~24 ⁴⁾	-25~24 ⁴⁾	-25~24 ⁴⁾	-25~24 ⁴⁾	-25~24 ⁴⁾

AHU kit PAW-P+100MAH4M			32 HP	34 HP	36 HP	38 HP	40 HP	42 HP	44 HP	46 HP	48 HP
AHU connection kit			174EEVPACK	174EEVPACK	174EEVPACK	174EEVPACK	174EEVPACK	174EEVPACK	174EEVPACK	174EEVPACK	174EEVPACK
Outdoor unit			2×U-10MZ1E8 + U-12MZ1E8	U-10MZ1E8 + 2×U-12MZ1E8	3×U-12MZ1E8	U-8MZ1E8 + 3×U-10MZ1E8	4×U-10MZ1E8	3×U-10MZ1E8 + U-12MZ1E8	2×U-10MZ1E8 + 2×U-12MZ1E8	U-10MZ1E8 + 3×U-12MZ1E8	4×U-12MZ1E8
Multi combination			10+10+12	10+12+12	12+12+12	8+10+10+10	10+10+10+10	10+10+10+12	10+10+12+12	10+12+12+12	12+12+12+12
Nominal cooling capacity	kW		89,5	95,0	100,0	106,0	112,0	117,0	123,0	128,0	134,0
Nominal heating capacity	kW		100,0	106,0	112,0	119,0	126,0	132,0	138,0	144,0	150,0
Minimum cooling continuous ¹⁾	kW		32,8	32,8	32,8	32,8	32,8	32,8	32,8	32,8	32,8
Minimum heating continuous ²⁾	kW		37,1	37,1	37,1	37,1	37,1	37,1	37,1	37,1	37,1
Air flow volume	Min	m ³ /h	6000	6000	6000	7700	8000	8000	8000	8000	8000
	Max	m ³ /h	30000	30000	30000	34000	36000	38000	40000	40000	40000
AHU DX coil heat exchanger volume	Min	dm ³	6,0	6,0	6,0	8,0	8,0	8,0	8,0	8,0	8,0
	Max	dm ³	32,0	34,0	36,0	38,0	40,0	42,0	44,0	46,0	48,0
Piping length	Min / Max	m	10/100	10/100	10/100	10/100	10/100	10/100	10/100	10/100	10/100
Maximum branch pipe length	m		12	12	12	12	12	12	12	12	12
Maximum pipe length difference after 1st joint	m		10	10	10	10	10	10	10	10	10
Maximum elevation difference (in / out)	m		10	10	10	10	10	10	10	10	10
Piping connections EEV	mm		7/8"	7/8"	7/8"	7/8"	7/8"	7/8"	7/8"	7/8"	7/8"
Piping diameter branch pipe	Liquid	Inch (mm)	5/8(15,88)	5/8(15,88)	5/8(15,88)	5/8(15,88)	5/8(15,88)	5/8(15,88)	5/8(15,88)	5/8(15,88)	5/8(15,88)
	Gas	Inch (mm)	1 3/8(34,98)	1 3/8(34,98)	1 3/8(34,98)	1 3/8(34,98)	1 3/8(34,98)	1 3/8(34,98)	1 3/8(34,98)	1 3/8(34,98)	1 3/8(34,98)
On coil temperature	Cool Min ~ Max	°C DB	12~32	12~32	12~32	12~32	12~32	12~32	12~32	12~32	12~32
		°C WB	8~25	8~25	8~25	8~25	8~25	8~25	8~25	8~25	8~25
	Heat Min ~ Max	°C DB	0~32 ³⁾	0~32 ³⁾	0~32 ³⁾	0~32 ³⁾	0~32 ³⁾	0~32 ³⁾	0~32 ³⁾	0~32 ³⁾	0~32 ³⁾
Outdoor temperature	Cool Min ~ Max	°C DB	-10~50	-10~50	-10~50	-10~50	-10~50	-10~50	-10~50	-10~50	-10~50
	Heat Min ~ Max	°C WB	-25~24 ⁴⁾	-25~24 ⁴⁾	-25~24 ⁴⁾	-25~24 ⁴⁾	-25~24 ⁴⁾	-25~24 ⁴⁾	-25~24 ⁴⁾	-25~24 ⁴⁾	-25~24 ⁴⁾

1) At rated condition with 35 °C DB outdoor and 27 °C DB / 19 °C WB on coil. 2) At rated condition with 7 °C DB / 6 °C WB outdoor and 20 °C DB on coil. 3) In case of on coil temperature of 5 °C or below and of 31 °C and above air flow would be restricted. 4) In case of on coil temperature > +18 °C WB in heating mode, intermittent operation could happen.

AHU connection kit MAH4M for ECOi 2-Pipe - R410A

- Space-saving compact casing
- Direct Modbus communication without the need for an additional interface
- Accurate control with a pressure transducer
- PAW-P+100MAH4M (H x W x D): 300 x 400 x 150 mm, 11 kg



Built-in controller.



AHU kit PAW-P+100MAH4M		4 HP	5 HP	6 HP	8 HP LE1	8 HP ME2	10 HP LE1
AHU connection kit		116EEVPACK	116EEVPACK	116EEVPACK	133EEVPACK	133EEVPACK	133EEVPACK
Outdoor unit		U-4LE2E5(8)	U-5LE2E5(8)	U-6LE2E5(8)	U-8LE1E8	U-8ME2E8	U-10LE1E8
Nominal cooling capacity	kW	12,0	14,0	16,0	22,4	22,4	28,0
Nominal heating capacity	kW	12,5	16,0	17,0	25,0	25,0	31,5
Minimum cooling continuous ¹⁾	kW	4,3	4,3	4,3	7,0	7,0	7,0
Minimum heating continuous ²⁾	kW	5,0	5,0	5,0	8,1	8,1	8,1
Air flow volume	Min	m ³ /h	1100	1100	1100	1700	2000
	Max	m ³ /h	4000	5000	5000	8000	10000
AHU DX coil heat exchanger volume	Min	dm ³	1,5	1,5	1,5	2,0	2,0
	Max	dm ³	5,5	6,3	7,0	7,0	10,0
Piping length	Min / Max	m	10/100	10/100	10/100	10/100	10/100
Maximum branch pipe length	m	12	12	12	12	12	12
Maximum pipe length difference after 1st joint	m	10	10	10	10	10	10
Maximum elevation difference (in / out)	m	10	10	10	10	10	10
Piping connections EEV	mm	8	8	8	10	10	10
Piping diameter branch pipe	Liquid	Inch (mm)	3/8(9,52)	3/8(9,52)	3/8(9,52)	3/8(9,52)	3/8(9,52)
	Gas	Inch (mm)	5/8(15,88)	5/8(15,88)	5/8(15,88)	3/4(19,05)	7/8(22,22)
On coil temperature	Cool Min ~ Max	°C DB	12/32	12/32	12/32	12/32	12/32
		°C WB	8/25	8/25	8/25	8/25	8/25
	Heat Min ~ Max	°C DB	0/32 ³⁾	0/32 ³⁾	0/32 ³⁾	0/32 ³⁾	0/32 ³⁾
		°C WB	8/25	8/25	8/25	8/25	8/25
Outdoor temperature	Cool Min ~ Max	°C DB	-10/46	-10/46	-10/46	-10/46	-10/46
	Heat Min ~ Max	°C WB	-20/18	-20/18	-20/18	-20/18	-20/18

AHU kit PAW-P+100MAH4M		10 HP ME2	12 HP	14 HP	16 HP	18 HP	20 HP
AHU connection kit		133EEVPACK	133EEVPACK	145EEVPACK	145EEVPACK	145EEVPACK	156EEVPACK
Outdoor unit		U-10ME2E8	U-12ME2E8	U-14ME2E8	U-16ME2E8	U-18ME2E8	2xU-10ME2E8
Nominal cooling capacity	kW	28,0	33,5	40,0	45,0	50,0	56,0
Nominal heating capacity	kW	31,5	37,5	45,0	50,0	56,0	63,0
Minimum cooling continuous ¹⁾	kW	7,0	7,0	10,4	10,4	10,4	15,3
Minimum heating continuous ²⁾	kW	8,1	8,1	12,0	12,0	12,0	17,5
Air flow volume	Min	m ³ /h	2000	2000	3500	3500	5000
	Max	m ³ /h	10000	10000	12000	12000	20000
AHU DX coil heat exchanger volume	Min	dm ³	2,0	3,0	3,0	4,0	4,0
	Max	dm ³	10,0	17,0	17,0	17,0	19,0
Piping length	Min / Max	m	10/100	10/100	10/100	10/100	10/100
Maximum branch pipe length	m	12	12	12	12	12	12
Maximum pipe length difference after 1st joint	m	10	10	10	10	10	10
Maximum elevation difference (in / out)	m	10	10	10	10	10	10
Piping connections EEV	mm	10	10	10	10	10	16
Piping diameter branch pipe	Liquid	Inch (mm)	3/8(9,52)	1/2(12,70)	1/2(12,70)	1/2(12,70)	5/8(15,88)
	Gas	Inch (mm)	7/8(22,22)	1 1/8(28,58)	1 1/8(28,58)	1 1/8(28,58)	1 1/8(28,58)
On coil temperature	Cool Min ~ Max	°C DB	12/32	12/32	12/32	12/32	12/32
		°C WB	8/25	8/25	8/25	8/25	8/25
	Heat Min ~ Max	°C DB	0/32 ³⁾	0/32 ³⁾	0/32 ³⁾	0/32 ³⁾	0/32 ³⁾
		°C WB	8/25	8/25	8/25	8/25	8/25
Outdoor temperature	Cool Min ~ Max	°C DB	-10/46	-10/46	-10/46	-10/46	-10/46
	Heat Min ~ Max	°C WB	-25/18	-25/18	-25/18	-25/18	-25/18

1) At rated condition with 35 °C DB outdoor and 27 °C DB / 19 °C WB on coil. 2) At rated condition with 7 °C DB / 6 °C WB outdoor and 20 °C DB on coil. 3) In case of on coil temperature of 5 °C or below and of 31 °C and above air flow would be restricted.



AHU connection kit MAH4M for ECOi 2-Pipe combination from 22 to 34 HP - R410A

ECO *i* EX ECO *i*



Built-in controller.

AHU kit PAW-P+100MAH4M			22 HP	24 HP	26 HP	28 HP	30 HP	32 HP	34 HP
AHU connection kit			156EEVPACK	174EEVPACK	174EEVPACK	174EEVPACK	174EEVPACK	174EEVPACK	174EEVPACK
Outdoor unit			U-10ME2E8 + U-12ME2E8	2xU-12ME2E8	U-10ME2E8 + U-16ME2E8	U-12ME2E8 + U-16ME2E8	U-14ME2E8 + U-16ME2E8	2xU-16ME2E8	U-14ME2E8 + U-20ME2E8
Multi combination			10+12	12+12	10+16	12+16	14+16	16+16	14+20
Nominal cooling capacity	kW		61,5	68,0	73,0	78,5	85,0	90,0	96,0
Nominal heating capacity	kW		69,0	76,5	81,5	87,5	95,0	100,0	108,0
Minimum cooling continuous ¹⁾	kW		15,3	21,5	21,5	21,5	21,5	21,5	21,5
Minimum heating continuous ²⁾	kW		17,5	24,7	24,7	24,7	24,7	24,7	24,7
Air flow volume	Min	m ³ /h	6000	6000	6000	6000	7000	7000	8500
	Max	m ³ /h	24000	24000	24000	25000	25000	25000	30000
AHU DX coil heat exchanger volume	Min	dm ³	5,0	6,0	6,0	6,0	6,0	6,0	7,0
	Max	dm ³	27,0	34,0	27,0	34,0	34,0	34,0	36,0
Piping length	Min / Max	m	10/100	10/100	10/100	10/100	10/100	10/100	10/100
Maximum branch pipe length		m	12	12	12	12	12	12	12
Maximum pipe length difference after 1st joint		m	10	10	10	10	10	10	10
Maximum elevation difference (in / out)		m	10	10	10	10	10	10	10
Piping connections EEV		mm	16	7/8"	7/8"	7/8"	7/8"	7/8"	7/8"
Piping diameter branch pipe	Liquid	Inch (mm)	5/8(15,88)	5/8(15,88)	3/4(19,05)	3/4(19,05)	3/4(19,05)	3/4(19,05)	3/4(19,05)
	Gas	Inch (mm)	1 1/8(28,58)	1 1/8(28,58)	1 1/4(31,75)	1 1/4(31,75)	1 1/4(31,75)	1 1/4(31,75)	1 1/4(31,75)
On coil temperature	Cool Min ~ Max	°C DB	12/32	12/32	12/32	12/32	12/32	12/32	12/32
		°C WB	8/25	8/25	8/25	8/25	8/25	8/25	8/25
	Heat Min ~ Max	°C DB	0/32 ³⁾	0/32 ³⁾	0/32 ³⁾	0/32 ³⁾	0/32 ³⁾	0/32 ³⁾	0/32 ³⁾
Outdoor temperature	Cool Min ~ Max	°C DB	-10/46	-10/46	-10/46	-10/46	-10/46	-10/46	-10/46
	Heat Min ~ Max	°C WB	-25/18	-25/18	-25/18	-25/18	-25/18	-25/18	-25/18

1) At rated condition with 35 °C DB outdoor and 27 °C DB / 19 °C WB on coil. 2) At rated condition with 7 °C DB / 6 °C WB outdoor and 20 °C DB on coil. 3) In case of on coil temperature of 5 °C or below and of 31 °C and above air flow would be restricted.

Accessories

PAW-P+102SENSPACK	AHU connection kit sensor pack 1 (2 pcs of SENSOR PT1000 HT IP67 -50/250 CABLE 6 m PCK)
PAW-P+116EEVPACK	EEV pack 1 (1 pc of expansion valve ≤ 16,0 kW (R32 / R410A) and 1 pc of UNIPOLAR stator and filter strainers)
PAW-P+133EEVPACK	EEV pack 2 (1 pc of expansion valve ≤ 33,0 kW (R32 / R410A) and 1 pc of UNIPOLAR stator and filter strainers)
PAW-P+145EEVPACK	EEV pack 3 (1 pc of expansion valve ≤ 45,0 kW (R32 / R410A) and 1 pc of UNIPOLAR stator and filter strainers)

Accessories

PAW-P+156EEVPACK	EEV pack 4 (1 pc of expansion valve ≤ 61,5 kW (R32 / R410A) and 1 pc of UNIPOLAR stator and filter strainers)
PAW-P+174EEVPACK	EEV pack 5 (1 pc of expansion valve ≤ 96,0 kW (R32 / R410A) and 1 pc of UNIPOLAR stator and filter strainers)
PAW-P+100PGNEPACK	Remote control pack (1 pc of PGNE 132 x 64 mm, mounting panel and 1 pc of cable L= 1,5 m, telephone connectors)

AHU connection kit MAH3M for 3-Pipe ECOi EX MF3 Series



ECOi outdoor units shall be used for AHU connection kit. 2 models for VRF system: 5 HP (PAW-160MAH3M) and 10 HP (PAW-280MAH3M).

System example for large capacity (more than 56,0 kW).
 3 x [PCB, transformer, solenoid control valve, thermistor x 4 pcs, terminal base and electrical component box].
 Example 140 kW system.

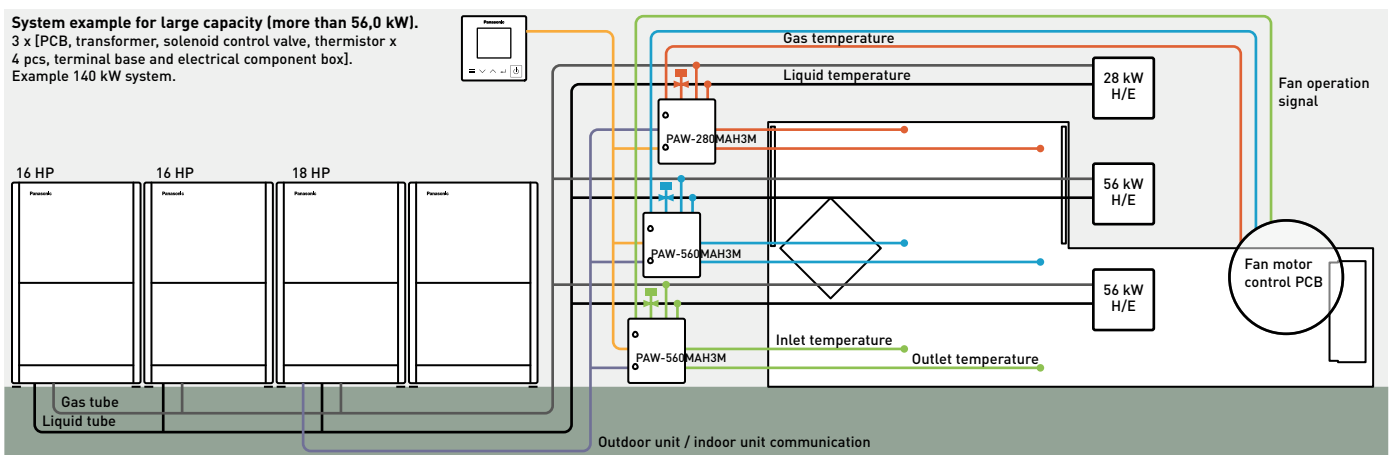

ECO*i*

AHU connection kit MAH3M for 3-Pipe ECOi EX MF3 Series - R410A



CONEX Bluetooth®
control built-in.
CZ-RTC6BL



Model			5 HP	10 HP
			PAW-160MAH3M	PAW-280MAH3M
Cooling capacity		kW	14,0	28,0
Heating capacity		kW	16,0	31,5
Air flow	Cool Min / Max	m³/h	1140 / 2600	3500 / 5000
Bypass factor recommended			0,9	0,9
Dimension	H x W x D	mm	500 x 400 x 150	500 x 400 x 150
Net weight		kg	11,5	11,5
Pipe length range		m	10 ~ 100	10 ~ 100
Elevation difference (in / out)	Max	m	10	10
Piping diameter	Liquid	Inch (mm)	3/8 (9,52)	3/8 (9,52)
	Gas	Inch (mm)	5/8 (15,88)	7/8 (22,22)
Intake temperature of AHU connection kit	Cool Min ~ Max	°C DB	+18 ~ +32	+18 ~ +32
	Cool Min ~ Max	°C WB	+13 ~ +23	+13 ~ +23
	Heat Min ~ Max	°C	+16 ~ +30	+16 ~ +30
Ambient temperature of outdoor unit	Cool Min ~ Max	°C	-10 ~ +43	-10 ~ +43
	Heat Min ~ Max	°C	-20 ~ +15	-20 ~ +15

Technical focus

- Maximum capacity / system: 10 HP (28 kW)
- Maximum piping length: 100 m (120 m equivalent)
- Elevation difference (indoor unit / indoor unit): 4 m
- In / out capacity ratio: 50~100%
- Maximum number of AHU connection kits: 4 units*
- Outdoor temperature range in heating: -20~+15 °C
- Available temperature range for the suction air at AHU connection kit: cool: +18~+32 °C / heat: +16~+30 °C
- The systems is controlled by the suction air (or room return air) temperature (same as standard indoor unit)
- The discharge air temperature is also controlled to prevent too-low air discharge in cooling or too-high air discharge in heating (in case of VRF)
- Demand control (forcible thermostat-OFF control by operating current)

- Defrost operation signal, Thermo-ON / OFF states output
- Drain pump control (drain pump and the float switch to be supplied in local)
- External target temperature setting via indoor / outdoor signal interface is available with CZ-CAPBC2 (Ex. 0-10 V)
- Demand control 40% to 120% (5% steps) by 0-10 V input signal
- Connectable with S-Link system. Special care for electrical noise may be necessary depending on the on-site system
- Fan control signal from the PCB can be used to control the air flow (high / mid / low and LL for Th-OFF). Need to change the fan control circuit wiring at field

*To be simultaneous operation controlled by one remote controller sensor.

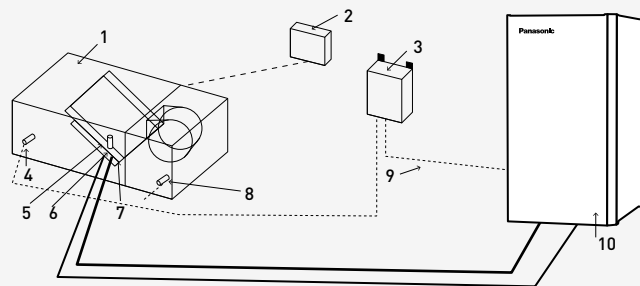

System and regulations. System overview.

- 1 | AHU Unit equipment (field supplied)
- 2 | AHU Unit system controller (field supplied)
- 3 | AHU connection kit controller box (with control PCB)
- 4 | Thermistor for discharge air
- 5 | Electronic expansion valve
- 6 | Thermistor for gas pipe (E3)
- 7 | Thermistor for liquid pipe (E1)
- 8 | Thermistor for suction air
- 9 | Inter-unit wiring
- 10 | ECOi or ECOi G outdoor unit

Optional controller.

Timer remote controller.
CZ-RTC5B.



Advanced energy recovery ventilation - ZY Series

Indoor air quality (IAQ) is a key consideration for any business owner looking to create a healthy and comfortable environment.



An energy recovery ventilator (ERV) provides balanced, energy efficient ventilation by transferring heat and moisture between incoming fresh filtered air and outgoing stale air. In the winter, an ERV keeps heat and moisture inside the building. During hot, humid summer months, it maintains cool, dry indoor air.

Recovers up to 83% of the heat in the outgoing air

ZY Series achieves more than 80% of heat exchange efficiency in all the line-up ¹⁾. The high recovery rate optimizes operation cost and can be considered as a sustainable solution.

1) Heating operation, H1 speed setting.

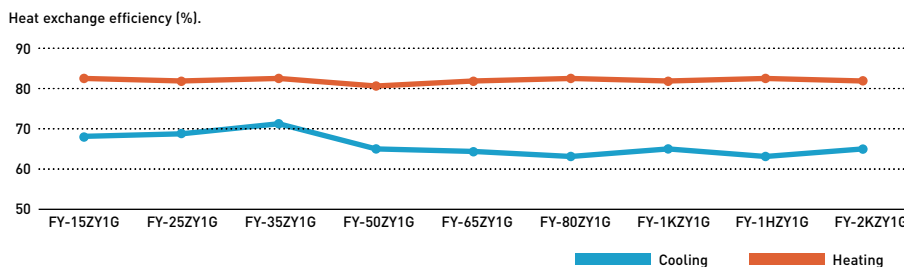

Ventilation volume setting PQ curve example.

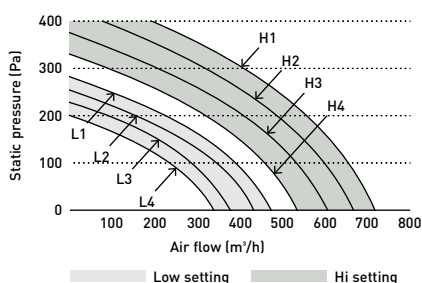

Easy adjust for air volume balance

DC motors are equipped with independent control settings for air supply and exhaust. Air volume balance can be easily adjusted with 4 speeds settings for each Hi / Low operation.



Advanced energy recovery ventilation - ZY Series

- Extended 9 model line-up including 2000 m³/h model
- DC motors
- ESP up to 150 Pa
- F7 grade filter built-in as a standard
- Intuitive remote controller
- BMS integration with RS485

Rated flow rate			150 m ³ /h	250 m ³ /h	350 m ³ /h	500 m ³ /h	650 m ³ /h	800 m ³ /h	1000 m ³ /h	1500 m ³ /h	2000 m ³ /h		
Indoor unit			FV-15ZY1G	FV-25ZY1G	FV-35ZY1G	FV-50ZY1G	FV-65ZY1G	FV-80ZY1G	FV-1KZY1G	FV-1HZY1G	FV-2KZY1G		
Power supply	Voltage	V	220 - 240	220 - 240	220 - 240	220 - 240	220 - 240	220 - 240	220 - 240	220 - 240	220 - 240		
	Phase		Single phase	Single phase	Single phase	Single phase	Single phase	Single phase	Single phase	Single phase	Single phase		
	Frequency	Hz	50	50	50	50	50	50	50	50	50		
Motor type			DC	DC	DC	DC	DC	DC	DC	DC	DC		
ERV													
Air flow	Max	m ³ /h	150	250	350	500	650	800	1000	1500	2000		
External static pressure	Max	Pa	100	120	140	130	150	150	150	130	130		
Sound pressure ²⁾	Max	dB(A)	37	38	39	43	45	45	46	49	51		
Input power	Max	W	76~84	106~117	141~155,5	180~198	420~462	470~517	550~605	940~1034	1100~1210		
Heat exchange efficiency ³⁾													
Cooling	Max	%	68,0	69,0	71,0	65,0	64,0	63,0	65,0	63,0	65,0		
Heating	Max	%	83,0	82,0	83,0	81,0	82,0	83,0	82,0	83,0	82,0		
Enthalpy exchange efficiency													
Cooling	Max	%	66,0	66,0	67,0	62,5	62,5	63,5	63,0	63,5	63,0		
Heating	Max	%	76,0	74,0	75,0	73,0	72,0	73,0	74,0	73,0	74,0		
Adapter diameter			mm	100	150	150	200	200	250	250	250		
Dimension			HxWxD	mm	289 x 610 x 860	289 x 735 x 860	331 x 874 x 968	331 x 1016 x 968	404 x 954 x 1008	404 x 1004 x 1224	404 x 1231 x 1224	808 x 1004 x 1224	808 x 1231 x 1224
Net weight			kg	23	27	37	40	48	60	64	119	142	

1) Different dimensions depending on models. 2) Measurement of noise 1,5 m below the center of the main unit (anechoic chamber). 3) Heat exchange efficiency measurement standard JIS B 8628 (2003). *JIS B 8628 (2017) is used in the measurement environment. *A remote controller is included.

Accessories

FV-FP15ZY1G	Replacement high-efficiency filter for FV-15ZY1G
FV-FP25ZY1G	Replacement high-efficiency filter for FV-25ZY1G
FV-FP35ZY1G	Replacement high-efficiency filter for FV-35ZY1G
FV-FP50ZY1G	Replacement high-efficiency filter for FV-50ZY1G

Accessories

FV-FP65ZY1G	Replacement high-efficiency filter for FV-65ZY1G
FV-FP80ZY1G	Replacement high-efficiency filter for FV-80ZY1G and FV-1HZY1G ¹⁾
FV-FP1KZY1G	Replacement high-efficiency filter for FV-1KZY1G and FV-2KZY1G ¹⁾

1) 2 sets of filters required for those models.

Highly efficient filter for better air supply

An effective EN F7 grade filter is built-in as a standard. Expected cleaning maintenance cycle is once per month, with an average of 4-6 months for replacement in high demand environments.

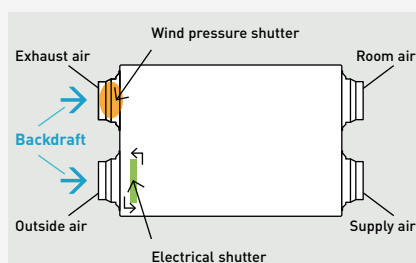

Backdraft shutters equipped as standard

A backdraft shutter prevents air flowing in the wrong direction when the ERV system is not in operation. The shutter at OA (outside air intake) side is inter-locked with ON / OFF switch. The shutter at EA (exhaust air outlet) side opens with the pressure generated by air stream then closes automatically.

Intuitive remote controller with RS485 connection.

- Simple and clean screen with white back light panel
- RS485 terminal equipped to integrate with Building Management Systems
- Metal switch box is included in the package



Energy recovery ventilation with DX coil - HRPT Series for VRF

The HRPT Series is specifically designed for commercial applications or collective residential buildings, offering highly efficient heat recovery of up to 85,2%. It's an ideal solution to achieve the highest energy certification for buildings in the tertiary, industrial and collective residential sectors including centralized condominium systems.



Highly efficient and flexible

The HRPT Series is a dual flow ventilation with an EC fan, ensuring high-efficiency heat recovery (>85% η). The series includes five models with air flow rates from 400 to 2000 m³/h. Two types of polystyrene heat exchangers (high-efficiency and sensible) are provided to meet a range of requirements.

HRPT Series line-up

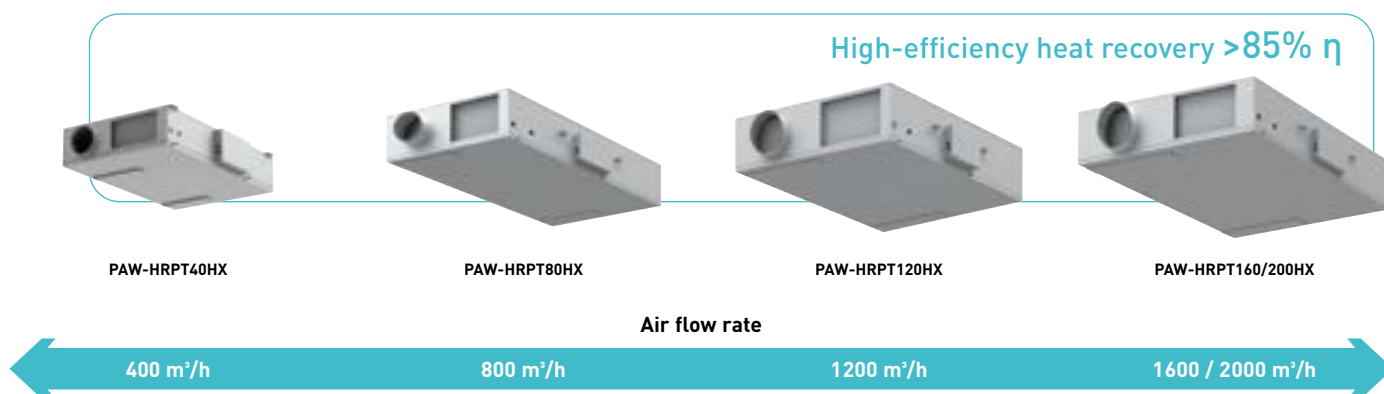

Quality meets efficiency. Explore the HRPT Series

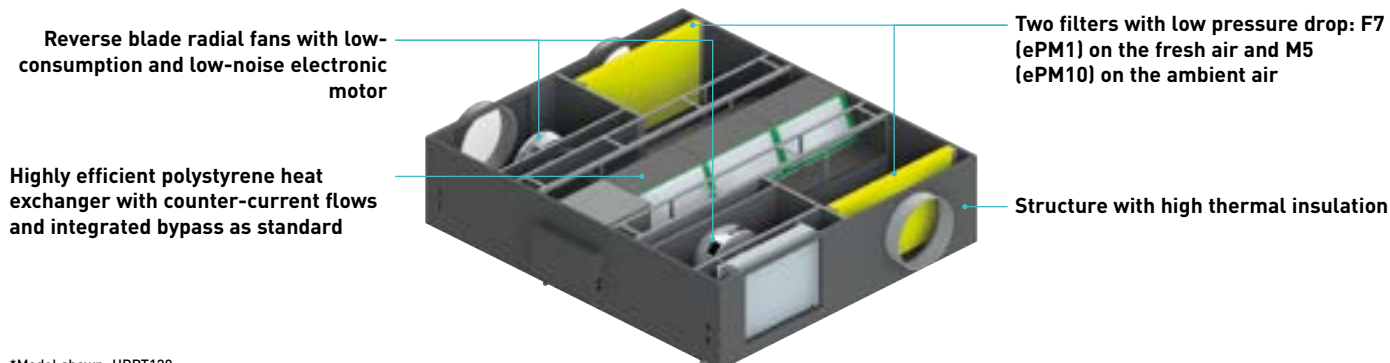

*Model shown: HRPT120.



Energy recovery ventilation with DX coil - HRPT Series - R32 / R410A

COMPATIBLE WITH ALL PANASONIC CONNECTIVITY SOLUTIONS. FOR DETAILED INFORMATION GO TO THE CONTROL SYSTEMS SECTION



Indoor unit with high-efficiency heat exchanger			PAW-HRPT40HX	PAW-HRPT80HX	PAW-HRPT120HX	PAW-HRPT160HX	PAW-HRPT200HX					
Power supply	Voltage	V	230	230	230	230	380					
	Phase		Single phase	Single phase	Single phase	Single phase	Three phase					
	Frequency	Hz	50	50	50	50	50					
Heat recovery ventilation ¹⁾			Cooling	Heating	Cooling	Heating	Cooling	Heating	Cooling	Heating		
Temperature efficiency	%		63,4	76,7	60,0	73,5	61,4	75,0	62,2	76,0	59,4	73,2
Enthalpy efficiency	%		52,3	53,2	47,8	49,2	49,5	50,7	50,0	51,2	46,8	48,3
Weight	kg		70		114		150		184		194	

Indoor unit with sensible heat exchanger			PAW-HRPT40	PAW-HRPT80	PAW-HRPT120	PAW-HRPT160	PAW-HRPT200					
Power supply	Voltage	V	230	230	230	230	380					
	Phase		Single phase	Single phase	Single phase	Single phase	Three phase					
	Frequency	Hz	50	50	50	50	50					
Heat recovery ventilation ¹⁾			Cooling	Heating	Cooling	Heating	Cooling	Heating	Cooling	Heating		
Temperature efficiency	%		84,6	84,9	84,3	84,7	84,8	85,2	84,7	85,1	83,8	84,2
Weight	kg		66		110		145		180		190	

Common data

DX coil ²⁾			Cooling	Heating	Cooling	Heating	Cooling	Heating	Cooling	Heating	Cooling	Heating
Total / Sensible capacity	kW		3,0 / 2,4	3,2	6,0 / 4,1	6,2	8,0 / 5,5	8,3	10,0 / 7,1	11,0	12,5 / 8,6	12,8
Maximum input current	A		1,5		2,2		4,1		4,4		3,3	
Sound pressure @1 m / @3 m	dB(A)		41 / 35		51 / 43		42 / 36		49 / 41		57 / 49	
Air flow	Nominal	m ³ /h	400		800		1200		1600		2000	
External static pressure	High	Pa	150		150		150		150		150	
Dimension	H x W x D	mm	286 x 1003 x 1475		425 x 1226 x 1878		425 x 1628 x 1878		425 x 2030 x 1720		425 x 2030 x 1878	
Piping diameter	Liquid	Inch (mm)	1/4 (6,35)		1/4 (6,35)		3/8 (9,52)		3/8 (9,52)		3/8 (9,52)	
	Gas	Inch (mm)	1/2 (12,70)		1/2 (12,70)		5/8 (15,88)		5/8 (15,88)		5/8 (15,88)	

1) Data refers to the following conditions (UNI EN 13141-7): nominal air flow, heating external air 5 °C with 72% r. / expelled air 25 °C with 28% r. - cooling 35 °C with 40% / expelled air 27 °C with 48%. 2) Data refers to the following conditions: nominal air flow, cooling inlet coil summer 27 °C with 48% / heating inlet coil winter 20 °C with 50% r. *Image is for PAW-HRPT40.

Accessories

CZ-RTC6W	CONEX wired remote controller (non-wireless), white
CZ-RTC6WBL	CONEX wired remote controller with Bluetooth®, white
CZ-RTC6	CONEX wired remote controller (non-wireless), black
CZ-RTC6BL	CONEX wired remote controller with Bluetooth®, black
CZ-RTC5B	Wired remote controller with Econavi function

Accessories

CZ-RWS3 + CZ-RWRC3	Infrared remote controller and receiver
PAW-RE2C4-MOD-WH	Room controller for hotel rooms, white
PAW-RE2C4-MOD-BK	Room controller for hotel rooms, black
PAW-RE2D4-WH	Display control for hotel rooms, white
PAW-RE2D4-BK	Display control for hotel rooms, black

Technical focus

- Dual flow ventilation with EC fan, featuring high-efficiency heat recovery (>85% η)
- 5 model line-up is available with air flow rates of 400, 800, 1200, 1600 and 2000 m³/h
- 2 types of polystyrene heat exchanger (high-efficiency and sensible) with counter-current flows and integrated bypass as standard
- Automatic defrosting of the exchanger
- Low consumption and EC motors with electronic speed control ensure high useful static pressure for circular inlet connection to air ducts
- Wide ambient temperature range up to +50 °C and down to -15 °C
- Modbus connection available

Interconnection to outdoor / indoor units

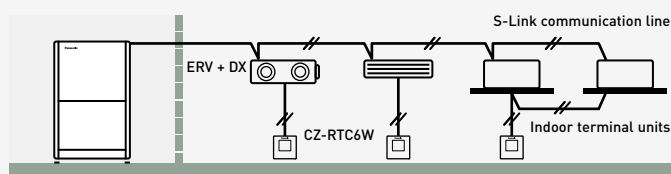

Aeraulic performance

EC motors with electronic speed control ensure high values of effective static pressure for ducting.

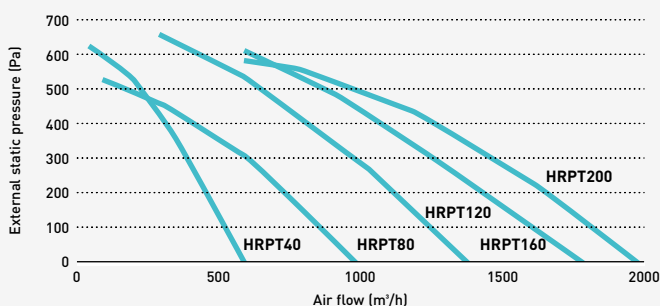

NEW! Air curtain with DX coil, connected to PACi NX systems

- Advanced defrost control without disrupting the air curtain effect or causing cold drafts
- Flexible installation: suspended as standard, cassette or built-in optional
- Quiet operation



Touch screen remote controller*

*Includes two remote controllers: a touch screen remote controller and CZ-RTC6 installed inside of the unit for setup.

Air outlet height 2,8 m			PAW-P2-100R			PAW-P2-150R			PAW-P2-200R			PAW-P2-250R			
Outdoor unit			U-50PZH3E5	U-60PZH3E5	U-71PZH4E5/8	U-100PZH4E5/8 U-100PZ3E5/8	U-125PZH4E5/8 U-125PZ3E5/8	U-140PZH4E5/8	U-100PZH4E5/8 U-100PZ3E5/8	U-125PZH4E5/8 U-125PZ3E5/8	U-140PZH4E5/8	U-200PZH4E8	U-250PZH4E8	U-200PZH4E8	U-250PZH4E8
Cooling capacity ¹⁾	Max	kW	5,6	6,3	7,8	11,4	12,0	12,0	11,4	13,6	15,3	16,3	16,3	20,0	20,5
Heating capacity ²⁾	Max	kW	6,5	7,0	8,0	12,0	13,0	15,0	12,1	15,0	17,4	20,9	20,9	22,0	25,0
Air flow	High	m ³ /h	1800			2700			3600			4500			
Heat exchanger	Volume	L	1,60			2,80			3,90			5,10			
Electric consumption fan	230 V/50 Hz	kW	0,33			0,50			0,66			0,83			
Current	230 V/50 Hz	A	2,40			3,60			4,80			6,00			
Sound pressure ³⁾	Max	dB(A)	56			57			58			59			
Dimension	H x W x D (x D ⁴⁾)	mm	300 x 1000 x 750 (x 890)			300 x 1500 x 750 (x 890)			300 x 2000 x 750 (x 890)			300 x 2500 x 750 (x 890)			
Net weight		kg	61			74			96			138			
Fan type			EC			EC			EC			EC			
Piping diameter ⁵⁾	Liquid / Gas	Inch (mm)	1/4 (6,35) / 1/2 (12,7)	1/4 (6,35) / 1/2 (12,7)	3/8 (9,52) / 5/8 (15,88)	3/8 (9,52) / 5/8 (15,88)	3/8 (9,52) / 5/8 (15,88)	3/8 (9,52) / 5/8 (15,88)	3/8 (9,52) / 5/8 (15,88)	3/8 (9,52) / 5/8 (15,88)	1/2 (12,70) / 7/8 (22,22)	1/2 (12,70) / 7/8 (22,22)	1/2 (12,70) / 7/8 (22,22)	1/2 (12,70) / 7/8 (22,22)	
Maximum pipe length		m	40	40	60	PZH: 60, PZ: 50	PZH: 100, PZ: 50	100	PZH: 60, PZ: 50	PZH: 100, PZ: 50	100	100	100	100	100
Door width		m	1,0			1,5			2,0			2,5			
Refrigerant			R32			R32			R32			R32			

Air outlet height 3,2 m			PAW-P3-100R			PAW-P3-150R			PAW-P3-200R		PAW-P3-250R	
Outdoor unit			U-100PZH4E5/8 U-100PZ3E5/8	U-125PZH4E5/8 U-125PZ3E5/8	U-140PZH4E5/8	U-100PZH4E5/8 U-100PZ3E5/8	U-125PZH4E5/8 U-125PZ3E5/8	U-140PZH4E5/8	U-200PZH4E8	U-250PZH4E8	U-200PZH4E8	U-250PZH4E8
Cooling capacity ¹⁾	Max	kW	10,0			11,4	13,6	13,8	20,0	21,7	20,0	25,2
Heating capacity ²⁾	Max	kW	12,0			12,0	13,0	15,0	22,0	25,0	22,0	25,0
Air flow	High	m ³ /h	2400			3200			4900		5700	
Heat exchanger	Volume	L	1,60			2,80			3,90		5,10	
Electric consumption fan	230 V/50 Hz	kW	0,50			0,66			0,99		1,16	
Current	230 V/50 Hz	A	3,60			4,80			7,20		8,40	
Sound pressure ³⁾	Max	dB(A)	58			59			60		61	
Dimension	H x W x D (x D ⁴⁾)	mm	300 x 1000 x 750 (x 890)			300 x 1500 x 750 (x 890)			300 x 2000 x 750 (x 890)		300 x 2500 x 750 (x 890)	
Net weight		kg	65			78			104		145	
Fan type			EC			EC			EC		EC	
Piping diameter ⁵⁾	Liquid / Gas	Inch (mm)	3/8 (9,52) / 5/8 (15,88)			3/8 (9,52) / 5/8 (15,88)			1/2 (12,70) / 7/8 (22,22)		1/2 (12,70) / 7/8 (22,22)	
Maximum pipe length		m	PZH: 60, PZ: 50	PZH: 100, PZ: 50	100	PZH: 60, PZ: 50	PZH: 100, PZ: 50	100	100	100	100	100
Door width		m	1,0			1,5			2,0		2,5	
Refrigerant			R32			R32			R32		R32	

1) Minimum discharge temperature of 17 °C, with an air intake temperature of 27 °C, evaporation temperature of 6 °C, compressed gas temperature of 48 °C, SH 5 K, SC 15 K. 2) Air intake temperature of 20 °C, refrigerant R32, outside temperature - 0 °C, compressed gas temperature 70 °C, condensation temperature 49 °C (for U50/U60/U71 55 °C, for U200/U250 48 °C), SC 3 K. 3) Measured in distance from 3,0 m. 4) Depth including brackets for cassette mounting and built-in models. For built-in model height changes + 100 mm for the channels. 5) Piping diameter to outdoor unit. Air curtain port connection for all sizes is 1/2 (12,7 mm) / 7/8 (22,00 mm). For smaller models, field-supplied adapters are required to ensure proper pipe connection.

Accessories

PAW-CDP1 Drain pump kit

Technical focus

- Advanced defrost control maintains the air curtain effect without cold drafts
- Four air curtain lengths available: P2 and P3 - 1,0 m, 1,5 m, 2,0 m, and 2,5 m
- Installation height up to 3,2 m
- Flexible installation: suspended as standard, cassette or built-in optional*
- Includes one user-friendly touchscreen remote controller
- Effortless settings management via touchscreen control
- Optional smart temperature control automatically adjusts to outdoor conditions
- Integrated control with door sensor and BMS ON / OFF functionality
- Scalable setup: group up to 10 units for synchronized operation
- Drain pump optional

*Cassette type (PAW-P2-100/150/200/250GVP) or built-in type (PAW-P3-100/150/200/250BVP) available upon request.

Installation heights and three mounting possibilities

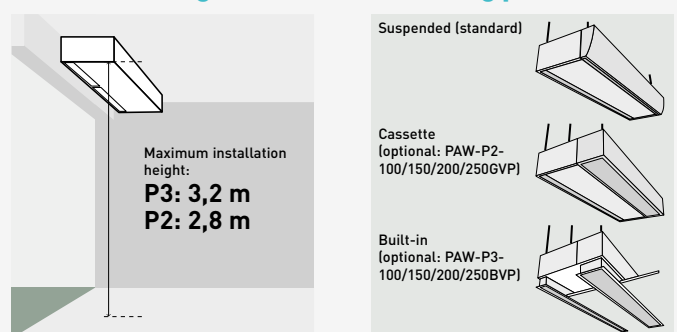



Touch screen
remote
controller*.

NEW! Air curtain with DX coil, connected to ECOi 2-Pipe

- Advanced defrost control without disrupting the air curtain effect or causing cold drafts
- Flexible installation: suspended as standard, cassette or built-in optional
- Quiet operation

*Includes two remote controllers: a touch screen remote controller and an intelligent built-in controller for setup.

Air outlet height 2,8 m			PAW-M2-100R	PAW-M2-150R	PAW-M2-200R	PAW-M2-250R
Outdoor unit minimum size			4 HP	5 HP	8 HP	10 HP
Cooling capacity ¹⁾	Max	kW	7,6	12,0	16,3	20,5
Heating capacity ²⁾	Max	kW	9,4	15,0	20,7	25,6
Air flow	High	m ³ /h	1800	2700	3600	4500
Heat Exchanger	Volume	L	1,60	2,80	3,90	5,10
Electric consumption fan	230 V / 50 Hz	kW	0,33	0,50	0,66	0,83
Current	230 V / 50 Hz	A	2,40	3,60	4,80	6,00
Sound pressure ³⁾	Max	dB(A)	56	57	58	59
Dimension	H x W x D (x D ⁴⁾)	mm	300 x 1000 x 750 (x 890)	300 x 1500 x 750 (x 890)	300 x 2000 x 750 (x 890)	300 x 2500 x 750 (x 890)
Net weight		kg	61	74	96	138
Fan type			EC	EC	EC	EC
Piping diameter ⁵⁾	Liquid / Gas	Inch (mm)	1/4 (6,35) / 1/2 (12,70)	3/8 (9,52) / 5/8 (15,88)	3/8 (9,52) / 5/8 (15,88)	1/2 (12,70) / 7/8 (22,22)
Door width		m	1,0	1,5	2,0	2,5
Refrigerant			R32 / R410A	R32 / R410A	R32 / R410A	R32 / R410A

Tentative data

Air outlet height 3,2 m			PAW-M3-100R	PAW-M3-150R	PAW-M3-200R	PAW-M3-250R
Outdoor unit minimum size			4 HP	6 HP	10 HP	10 HP
Cooling capacity ¹⁾	Max	kW	10,0	13,8	21,7	25,2
Heating capacity ²⁾	Max	kW	11,4	17,0	25,7	30,2
Air flow	High	m ³ /h	2400	3200	4900	5700
Heat Exchanger	Volume	L	1,60	2,80	3,90	5,10
Electric consumption fan	230 V / 50 Hz	kW	0,50	0,66	0,99	1,16
Current	230 V / 50 Hz	A	3,60	4,80	7,20	8,40
Sound pressure ³⁾	Max	dB(A)	58	59	60	61
Dimension	H x W x D (x D ⁴⁾)	mm	300 x 1000 x 750 (x 890)	300 x 1500 x 750 (x 890)	300 x 2000 x 750 (x 890)	300 x 2500 x 750 (x 890)
Net weight		kg	65	78	104	145
Fan type			EC	EC	EC	EC
Piping diameter ⁵⁾	Liquid / Gas	Inch (mm)	3/8 (9,52) / 5/8 (15,88)	3/8 (9,52) / 5/8 (15,88)	1/2 (12,70) / 7/8 (22,22)	1/2 (12,70) / 7/8 (22,22)
Door width		m	1,0	1,5	2,0	2,5
Refrigerant			R32 / R410A	R32 / R410A	R32 / R410A	R32 / R410A

1) Minimum discharge temperature of 17 °C. With an air intake temperature of 27 °C RH 50%, evaporation temperature of 4,5 °C, SH 3 K, SC 20 K. 2) Air intake temperature of 20 °C, refrigerant R32, outside temperature -0 °C, condensation temperature 48 °C, SH 40 K and SC 3 K. 3) Measured in distance from 3,0 m. 4) Depth including brackets for cassette mounting and built-in models. For built-in model height changes + 100 mm for the channels. 5) Piping diameter to outdoor unit. Air curtain port connection for all sizes is 1/2" (12,7 mm) / 7/8" (22,00 mm). For smaller models, field-supplied adapters are required to ensure proper pipe connection.

Accessories

PAW-CDP1 Drain pump kit

Technical focus

- Advanced defrost control maintains the air curtain effect without cold drafts
- Four air curtain lengths available: P2 and P3 – 1,0 m, 1,5 m, 2,0 m, and 2,5 m
- Installation height up to 3,2 m
- Flexible installation: suspended as standard, cassette or built-in optional*
- Includes one user-friendly touchscreen remote controller
- Effortless settings management via touchscreen control
- Optional smart temperature control automatically adjusts to outdoor conditions
- Integrated control with door sensor and BMS ON / OFF functionality
- Scalable setup: group up to 10 units for synchronized operation
- Drain pump optional

*Cassette type (PAW-M2-100/150/200/250GVP) or built-in type (PAW-M3-100/150/200/250BVP) available upon request.

Installation heights and three mounting possibilities

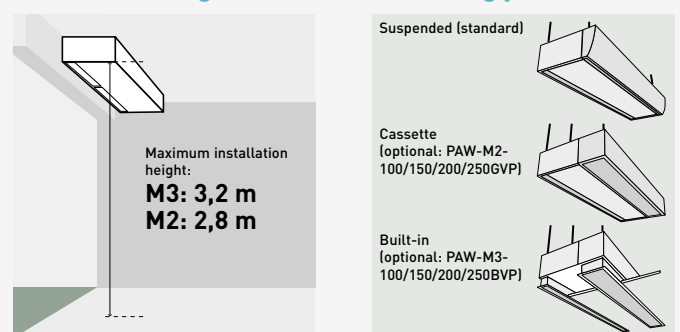



Electric air curtain

Designed to maximize performance: High air flow upgraded 145% compared to conventional model (in the case of FY-3009U1).

Comprehensive product line up: 1,5 m wide model added in the line up.

			FY-3009U1	FY-3012U1	FY-3015U1
Width	mm		900	1200	1500
Voltage	V		220	220	220
Air flow	Hi / Lo	m ³ /h	1100/920	1400/1270	2000/1800
Consumption	Hi / Lo	W	76/70	94/85	131/110
Current	Hi / Lo	A	0,35/0,32	0,43/0,40	0,59/0,50
Air speed	Hi / Lo	m/s	10,50/8,50	9,50/8,00	10,50/9,50
Sound pressure	Hi / Lo	dB(A)	48,5/45,0	48,5/44,5	51,5/48,0
Dimension	H x W x D	mm	900x231,5x212	1200x231,5x212	1500x231,5x212
Net weight		kg	12,0	14,5	18,0

Easier installation and maintenance.

Simple structure for easy installation and maintenance.





air-e™

+ nanoe™

Ceiling mounted air-e nanoe X Generator

- nanoe™ X technology
(Generator Mark 1: 4,8 trillion hydroxyl radicals/sec)
- Silent operation. Whisper quiet at 25,5 dB(A) (at 230 V)
- Low power consumption 4 W
- Easy installation
- Compact and modern design

Model	FV-15CSD1G				
Power supply	Voltage	V	220	230	240
	Frequency	Hz	50	50	50
Air flow	m³/h		15	16	17
	CFM		8,8	9,4	10,0
Consumption	W		4	4	4
Sound pressure	dB(A)		23,5	25,5	27,0
Net weight	kg			1,1	

*The value of air volume, power consumption and noise are specified at static pressure 0 Pa. The value of air volume is the mean value and a tolerance of +-10% is allowed. The value of noise level is a weighted average sound pressure level, the mean value is measured by Panasonic. A tolerance of +3 dB/-7 dB is allowed. The noise is measure at 1 m apart from the left, the front and below of the tested product. Conditions of generating nanoe™ X: room temperature: about 5 °C – 40 °C [dew point temperature more than 2 °C], relative humidity: about 30% – 85%. nanoe™ X is generated using the air in the room, and its amount is subject to the temperature and humidity in the air.

One device is suitable for around 10 m² (with a ceiling height 3 m)

Ex. 3 air-e devices are required for the room size 30 m².

The air-e is a stand alone device which is an easy and simple choice to improve indoor air quality. It can be easily installed to various commercial projects including refurbishments.

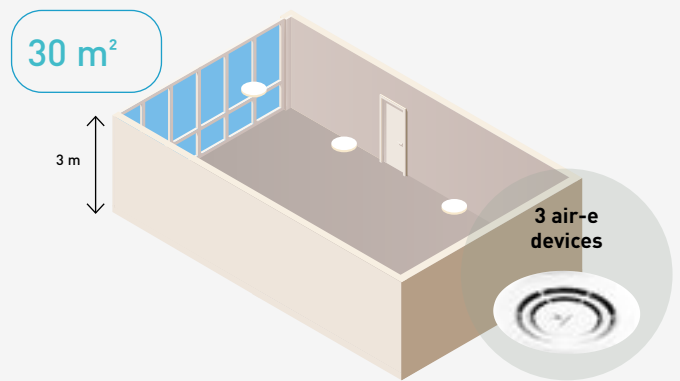

Ceiling mounted air-e nanoe X Generator. Bringing nature's balance indoors with Panasonic's unique nanoe™ X technology built into the air-e. Deodorises and inhibits certain bacteria, viruses, mould, pollens and allergens for better indoor air quality.

The tested effects of nanoe™ X

Bacteria and viruses.

SARS-CoV-2: 99,9% % inhibited ¹⁾
 Influenza virus H1N1 subtype: 99,9 % inhibited ²⁾

Odour.

nanoe X Generator can reduce cigarette smoke odour intensity by 2,4 levels in 12 minutes.

1) Novel coronavirus [SARS-CoV-2] > [Test organization] Texcell [France] [Test subject] Adhered novel coronavirus [SARS-CoV-2] [Test volume] 45 L enclosed box [Test result] Inhibited 99,9% in 2 hours [Test report] 1140-01 A1.
 2) Adhered virus [Influenza virus H1N1 subtype] > [Test organization] Kitasato Research Center for Environmental Science [Test subject] Influenza virus [H1N1 subtype] [Test volume] 1000 L enclosed box [Test result] Inhibited 99,9% in 2 hours [Test report] 21_0084_1.
 3) Deodorisation effect for adhering odour (cigarette smoke) > [Test organization] Panasonic Product Analysis Center [Test subject] Adhered cigarette smoke odour [Test volume] Approx. 24 m³ laboratory [Test result] Odour intensity reduced 2,4 levels in 0,2 hours [Test report] 4AA33-160615-N04.

Performance of nanoe™ X might differ in real life environment and is only expected in the same room as where the unit is placed. The nanoe™ X performance varies depending on the room size, environment and usage and it may take several hours to reach the full effect. nanoe™ X is not a medical device.

Deodorisation effect for adhering odour (cigarette smoke) ³⁾.

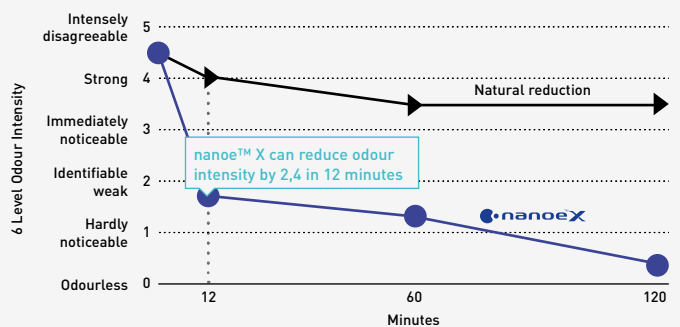

For further details and validation data, please refer to the following website.



High pressure duct and 100% fresh air duct function for all ECOi systems

The E2 range of ducted units offers improved design flexibility for extended duct layouts as a result of their increased external static pressures whilst reducing energy consumption, while providing fresh air to larger spaces.





E2 type high static pressure hide-away - R410A
High pressure duct and 100% fresh air duct function.

COMPATIBLE WITH ALL PANASONIC CONNECTIVITY SOLUTIONS. FOR DETAILED INFORMATION GO TO THE CONTROL SYSTEMS SECTION

Type	Indoor unit	100% fresh air duct function (by using kit for 100% fresh air)				High pressure duct			
		S-224ME2E5		S-280ME2E5		S-224ME2E5		S-280ME2E5	
		Cooling	Heating	Cooling	Heating	Cooling	Heating	Cooling	Heating
Capacity	kW	22,4	21,2	28,0	26,5	22,4	25,0	28,0	31,5
Input power	W	290,00	290,00	350,00	350,00	440,00	440,00	715,00	715,00
Current	A	1,85	1,85	2,20	2,20	2,45	2,45	3,95	3,95
Air flow	Hi/Med/Lo	m ³ /min 28,3/-/-		35,0/-/-		56,0/51,0/44,0		72,0/63,0/53,0	
External static pressure	Pa	200		200		140 (60 - 270) ¹⁾		140 (72 - 270) ¹⁾	
Sound pressure ²⁾	Hi/Med/Lo	dB(A) 43/-/-		44/-/-		45/43/41		49/47/43	
Sound power	Hi/Med/Lo	dB(A) 75/-/-		76/-/-		77/75/73		81/79/75	
Dimension	H x W x D	mm 479 x 1453 x 1205		479 x 1453 x 1205		479 x 1453 x 1205		479 x 1453 x 1205	
Net weight	kg	102		106		102		106	
Piping diameter	Liquid	Inch (mm) 3/8 (9,52)		3/8 (9,52)		3/8 (9,52)		3/8 (9,52)	
	Gas	Inch (mm) 3/4 (19,05)		7/8 (22,22)		3/4 (19,05)		7/8 (22,22)	

Rating conditions for 100% fresh air duct function: Cooling outdoor 33 °C DB / 28 °C WB. Heating outdoor 0 °C DB / -2,9 °C WB.
 1) Available to select the setting by initial setup. 2) Values with 140 Pa setting. *No filter included.

Accessories	
CZ-RTC6W	CONEX wired remote controller (non-wireless), white
CZ-RTC6WBL	CONEX wired remote controller with Bluetooth®, white
CZ-RTC6	CONEX wired remote controller (non-wireless), black
CZ-RTC6BL	CONEX wired remote controller with Bluetooth®, black
CZ-RTC5B	Wired remote controller with Econavi function
CZ-RW53 + CZ-RWRC3	Infrared remote controller and receiver

Accessories	
PAW-RE2C4-MOD-WH	Room controller for hotel rooms, white
PAW-RE2C4-MOD-BK	Room controller for hotel rooms, black
PAW-RE2D4-WH	Display control for hotel rooms, white
PAW-RE2D4-BK	Display control for hotel rooms, black
CZ-CENSC1	Econavi energy saving sensor

Technical focus

- No need of rap valves for standard operation
- 100% fresh air duct function*
- DC fan motor for more savings
- Complete flexibility for ductwork design
- Can be located within a weatherproof housing for external installation
- Air OFF sensor avoids cold air dumping
- Configurable air temperature control

*Rap valves required, see 100% fresh air duct function below.

100% fresh air duct function

The E2 duct with 100% fresh air duct function have exceptional discharge temperature.

	Discharge Range		
	Min	Max	Default
Cooling	15 °C	24 °C	18 °C
Heating	17 °C	45 °C	40 °C

System example

An inspection port (450 x 450 mm or more) is required at the lower side of the indoor unit body (field supply).

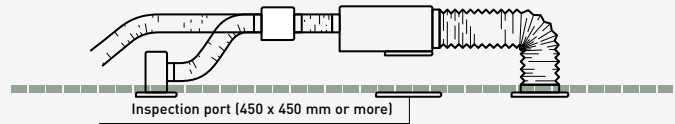

Plenums

Air outlet plenum (suitable for rigid + flexible duct)		
	Number of exits with diameters	Model
S-224ME2E5	1 x 500 mm	CZ-TREMIESPW705
S-280ME2E5	1 x 500 mm	CZ-TREMIESPW706

Kit for 100% fresh air function

Kit for 2 way systems		Kit for 3 way systems	
2x CZ-P160RVK2	Rap valve kit	2x CZ-P160HR3	3 way valve kit
2x CZ-CAPE2	3 way control PCB	2x CZ-CAPE2	3 way control PCB
CZ-P680BK2BM	Distribution joint kit	CZ-P680BH2BM	Distribution joint kit
	1x remote controller		1x remote controller



ECONAVI and INTERNET CONTROL: Optional.

Heat recovery ventilation unit

The heat recovery ventilation unit is design not only to provide a good indoor air quality, but it is also designed to recover heat that would otherwise be lost throughout ventilation. These heat recovery ventilation systems are used to assist in the retention of heat.

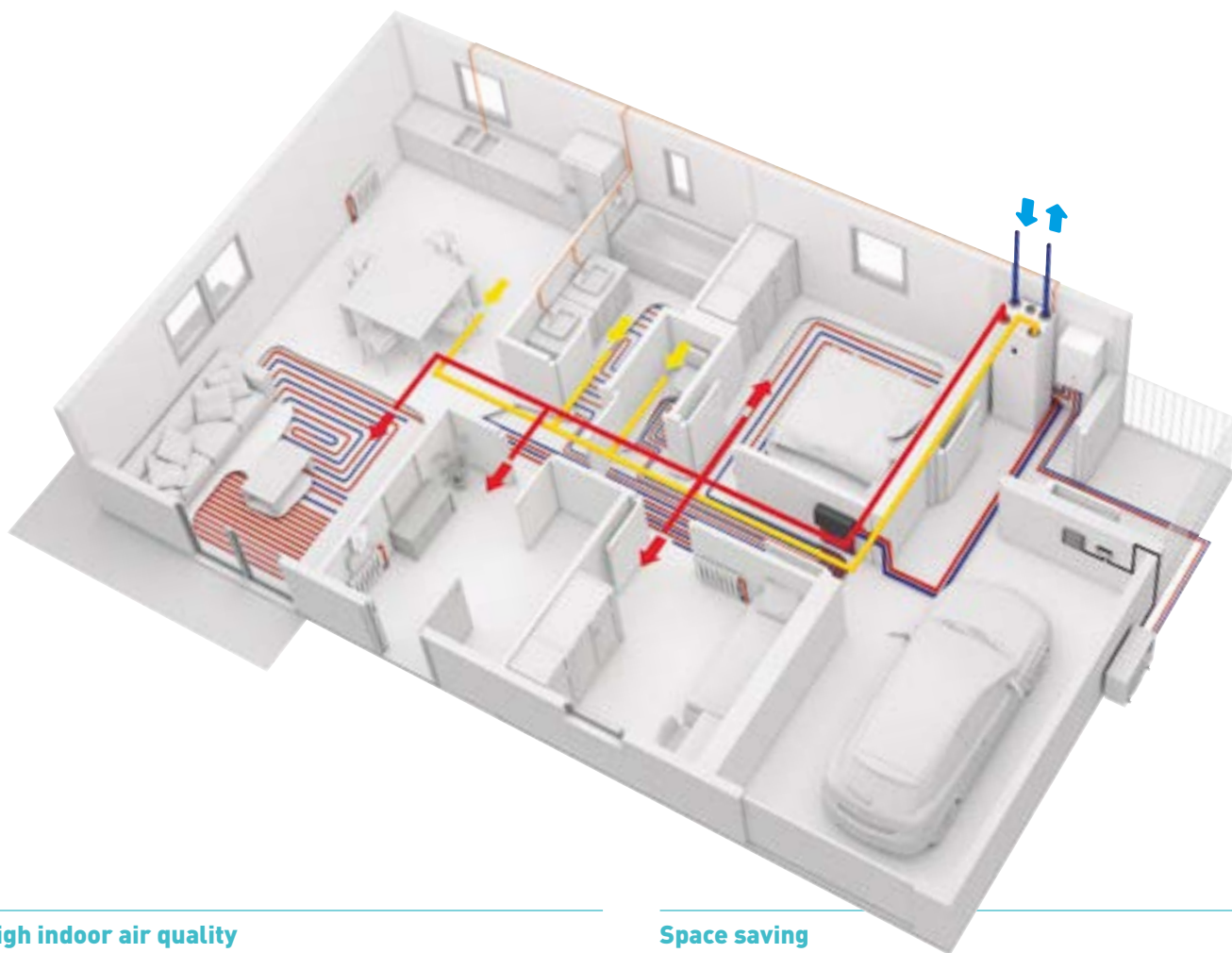

High indoor air quality

The unit is designed to provide fresh filtered air into the home, while keeping a high thermal comfort.

Energy saving

Most of the energy from the exhausted air is used to precondition the incoming air, leading to lower heating requirements in the building.

Space saving

The compact ventilation unit can be installed over the DHW square tank or the Aquarea All in One Compact indoor unit for an space saving solution.

Better user interface

The Residential ventilation unit and the Aquarea Heat Pumps can be controlled with one single user-friendly controller.

AQUAREA

Combine the Residential ventilation unit with Panasonic Aquarea for an space saving and highly efficient solution for heating, cooling, ventilation and DHW.



Heat Recovery Ventilation + Aquarea All in One Compact.

*The unit can be mounted on a All in One indoor unit (K, L or M Series) or installed on the wall (PAW-VEN-WBRK is needed).



PAW-A2W-VENTA-R

PAW-A2W-VENTA-L



Heat recovery ventilation unit



Model		PAW-A2W-VENTA-R	PAW-A2W-VENTA-L
Nominal air flow rate	m ³ /h	204 @ 50 Pa	
Maximum air flow rate	m ³ /h	292 @ 100 Pa	
SPF		1,24 @ 204 m ³ /h	
Heat exchanger rotor drive type		Variable speed	
Exchanger type		Rotating	
Heat recovery efficiency		84%	
Power supply	V / Hz	230 / 50 / Single phase	
Power consumption	W	176	
Energy class, basic unit		A	
Energy class, unit with local control on demand		A	
Noise level	dB(A)	40	
Dimension (HxWxD)	mm	450x598x500	
Weight	kg	46	
Mounting position		Vertical	
Supply side		Right	Left
Duct connections	mm	DN125	
Filter class, supply air		F7/ePM1 60%	
Filter class, extract air		M5/ePM10 50%	
Minimum outdoor temperature	°C	-20	

*Heat recovery efficiency according to EN 13141-7. **Heat recovery ventilation unit is produced by Systemair.

Accessories	
PAW-VEN-FLTKIT	Supply and extract filters kit
PAW-VEN-ACCPCB	Optional PCB for additional functions
PAW-VEN-DPL	HRV touch control panel. White frame (cable must be ordered separately)
PAW-VEN-CBLEXT12	Cable with plug for electrical connection between unit and control panel, type CE and CD (12 m)
PAW-VEN-DIVPLG	Twin plugs for installation of several control panels type CD or CE for one unit

Accessories	
PAW-VEN-DPLBOX	HRV touch control panel wall-mounted kit
PAW-VEN-S-C02RH-W	CO ₂ , RH wall-mounted sensor
PAW-VEN-S-C02-W	CO ₂ wall-mounted sensor
PAW-VEN-S-C02-D	CO ₂ duct sensor
PAW-VEN-WBRK	Wall bracket kit for stand-alone installation on the wall
PAW-VEN-HTR06	Electrical duct heater 0,6 kW (includes relay)
PAW-VEN-HTR12	Electrical duct heater 1,2 kW (includes relay)

Main features of the residential ventilation unit

- Designed for areas up to approximately 140 m²
- High energy efficiency rotary heat exchanger with EC - technology fans
- Moisture transfer function to minimize condensation in supply air during wintertime
- The built in humidity sensor in extract air can be used for demand control
- Control via touch display and Startup Wizard for easy commissioning

- Modbus communication via RS-485
- Option to control an Aquarea H Series onwards heat pump from PAW-A2W-VENTA control panel Modbus gateway (PAW-AZAW-MBS-M, PAW-AW-MBS-M, CZ-NSMB-C or CZ-NSMB) and PAW-VEN-ACCPCB required

Control user-friendly interface

All settings and features accessible via a control panel, integrated into the front cover. The option for connecting one or more external control panels is available.

- Color touch screen with a user-friendly interface
- MANUAL and AUTO mode or choose preferred settings from the pre-configured user modes

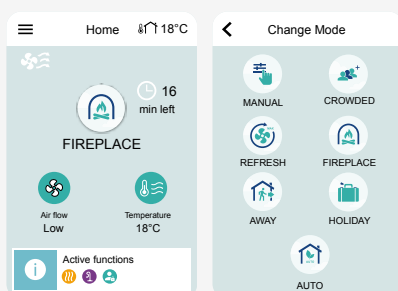

- If Aquarea H and J Series heat pumps are connected with PAW-A2W-VENTA, the heat pump control options appear on the home screen in a separate tab

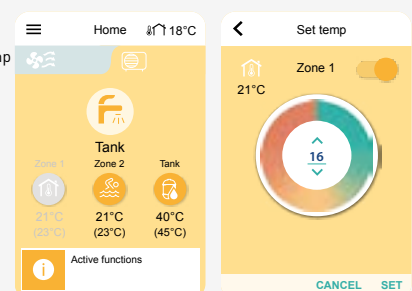

Aquarea Vent - Counter flow ventilation

Aquarea Vent systems provide a continuous supply of fresh air, ensuring optimal indoor air quality and comfort. Ideal for single-family homes or apartments with low energy requirements, Panasonic's HRV systems combine high-efficiency heat recovery, quiet operation, and advanced air filtration with flexible installation options.



Vent PRO.

Access the tool via the 'Tools' section in the Panasonic Pro Club (www.panasonicproclub.com).

From selecting the right ventilation unit to planning the air distribution system and choosing the appropriate components, the Vent PRO guides you through every step to ensure the optimal solution for your project.



Universal mounting.

Horizontal mounting.

Vertical mounting.



Aquarea Vent - Counter flow ventilation units



REFER TO PAGE 143 FOR THE COMPLETE LIST OF FILTERS AND ACCESSORIES FOR AIR DISTRIBUTION AND DIFFUSION SYSTEMS



			Universal mounting				Horizontal mounting			Vertical mounting			
P-VEN			15XQAZE5	20XQAZE5	30XQAZE5	15XQAHE5	30XQAHE5	35XQAHE5	45XQAHE5	15XQAVE5	30XQAVE5	40XQAVE5	45XQAVE5
Air flow	Nominal / Max	m ³ /h	91/130	147/210	224/320	109/155	210/300	238/340	288/455	112/170	210/300	266/380	315/450
Static pressure	Nominal / Max	Pa	50/100	50/100	50/100	50/100	50/100	50/100	50/100	50/100	50/100	50/100	50/100
Recovery efficiency		%	87	85	85	86	85	89	88	86	86	87	86
Energy class			A	A	A	A	A	A	A	A	A	A	A
Power supply	Voltage	V	230	230	230	230	230	230	230	230	230	230	230
	Phase		Single phase	Single phase	Single phase	Single phase	Single phase	Single phase	Single phase	Single phase	Single phase	Single phase	Single phase
	Frequency	Hz	50	50	50	50	50	50	50	50	50	50	50
Power consumption	Nominal	W	80	140	180	110	180	350	420	110	180	350	420
Sound power LWA		dB(A)	48	51	52	49	50	52	56	48	50	51	54
Dimension	H x W x D	mm	255 x 580 x 580	255 x 580 x 580	255 x 580 x 580	260 x 480 x 800	295 x 600 x 795	290 x 650 x 1150	290 x 1150 x 1150	510 x 430 x 625	590 x 575 x 785	590 x 735 x 785	590 x 785 x 735
Net weight		kg	19	19	19	25	30	38	40	32	38	42	43
Filter class			ePM1 80%	ePM1 80%	ePM1 80%	ePM1 80%	ePM1 70%	ePM1 70%	ePM1 70%	ePM1 80%	ePM1 70%	ePM1 70%	ePM1 70%
Duct connection		mm	160	160	160	160	160	160	160	160	160	160	160

HIGH-EFFICIENCY SENSIBLE HEAT RECOVERY

HIGHLY EFFICIENT AIR RENEWAL AND FILTRATION, WITH 80% EPM1 FILTERS

INTEGRATED AIR QUALITY, HUMIDITY AND TEMPERATURE SENSORS

REMOTE CONTROL VIA WI-FI (OPTIONAL)

Balanced ventilation

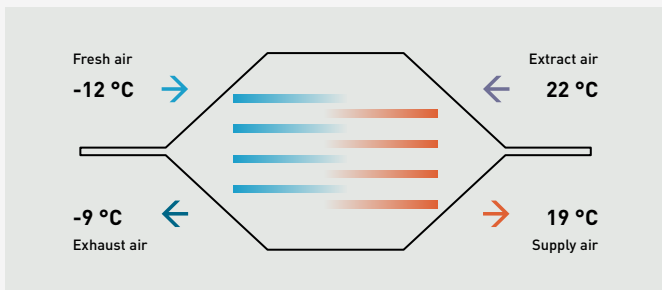

Counter flow ventilation units are equipped with two fans to supply and extract air. A cross-flow heat exchanger recovers the energy contained in the extracted air and transfers it to the supplied air. This significantly reduces the building's energy consumption, while at the same time keeping a good quality of the indoor air.

Control options (required, to be ordered separately).

Wall-mounted control with Modbus.

PCZ-AHRP0025

Wall-mounted control with integrated Wi-Fi for remote control via the Aquarea Home App.

PCZ-AHRP0026

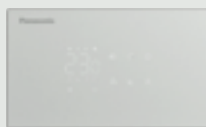

- Integrated VOC - CO₂ air quality sensors
- Integrated humidity sensors
- Integrated temperature sensors
- Unit control and settings: Seasonal modes, temperature and fan speed ventilation settings
- Connectivity: Wi-Fi or Modbus

Aquarea Home App

Download free app.

Other hardware requirements: Router and Internet (purchase and subscribe separately). Panasonic Cloud Server is designed, operated and managed by Panasonic.

*The app screen is for illustration purposes only. The actual screen may differ.

