

MONOBLOCS

Compact wine cellar air conditioners that incorporate
all of Friax's know-how



WineSupervisor 3

Your Cellar, Connected

Compatible with all Friax Céos and Vintage
Accessible from all your devices
Web - Smartphone - Tablet



Remote control

Monitor temperature and humidity in real time so you never miss a change in the storage atmosphere of your bottles. Take control remotely and adjust the settings.



Conservation history

The WineSupervisor 3 allows you to keep a complete history of the cellar atmosphere and the operating periods of Friax air conditioners. Insurance and proof of the good conservation of the bottles.



Mapping of your facilities

If you are user or installer in charge of site maintenance, find all your cellars on the map and be informed of their operating status directly on your smartphone screen.



Configurable alarms

Configure and receive real-time alarms to intervene when needed. Keep track of all events in the cellar. Give access to your technician for proper maintenance.

A la carte subscription formulas so that **WineSupervisor 3** and its connected interface can increase the functionality of your Friax

BASIC Formula

Free, included for life with WS3*
-Visualization of T and Hr%** values
-Live alarms

DEGUSTATION Formula

1 year free on commissioning then subscription or switch to BASIC***
-Visualization of T and Hr%** values
-Live alarms
-Expert Mode
-Curves of the different functions
-3 years of history
-Remote control
-Connected lighting
-Connected silent mode
-Maintenance access

API Formula

Subscription or automatic switch to BASIC***
-Visualization of T and Hr%** values
-Live alarms
-Expert mode
-Curves of the different functions
-10 years of history
-Remote control
-Connected lighting
-Connected silent mode
-Maintenance access
-Export of values for complete traceability of bottles over time

Also available in a Modbus version for integration into an existing supervision

Code	Description
KWSP-I	WineSupervisor I Kit - Modbus Version
KWSP-III	WineSupervisor 3 Kit - Connected Version

*Requires the installation of a WineSupervisor 3 box

** For Ceos and Vintage models

*** Annual settlement. If you decide not to renew your subscription, the switch to the free BASIC formula is done automatically, you stay connected!

Friax Monoblocs are easy to install devices. They do not necessarily require the intervention of a specialist.



Window MPCJ p **28**

The MPCJ is a monobloc with a refined and customizable design to transform the atmosphere of the wine cellar.



Ductable MPCG p **32**

Equipped with the ducted front, the MPCG monobloc can be installed inside or outside the cellar to optimize space.



Cabinet MPCCA p **36**

The Monobloc MPCCA has been specially developed to easily equip custom glass wine cabinets and small cellar spaces.



WINDOW MPCJ

The installation of a **Monobloc MPCJ** for the air conditioning of a cellar allows to overcome the constraints related to the refrigeration connections of a splits system thanks to a “window” cross-wall installation.

The modern and clean design of this wine cellar air conditioner can be **personalized** so that each cellar becomes unique.

Vintage finish

The Vintage appellation makes it possible to maintain a healthy cellar with air conditioning and heating regulation to limit temperature differences between seasons and best protect the wine. Vintage also incorporates the **KHGR%** humidification system. Connected to the city water network, it allows the humidity to be brought to the required value (ideally 65 -75%). No heat input, softened or demineralized water is not necessary. The use of a KLPWSECU kit will facilitate and secure its connection.

Remote control RSF2 new generation

This is the simplest solution to take control of your cellar conditioner. With the wireless radio frequency remote control **RSF2**, no more distance problem, the signal passes through walls. You can control your cellar right up to your kitchen. On Vintage models, it displays temperature and humidity.

Customizable

The modern and clean design of this cellar air conditioner can be personalized so that each wine cellar becomes unique. The interchangeable colored front allows endless possibilities. The MPCJ comes standard with a glossy black front.

WineSupervisor

This is the connected solution. Whatever your environment, Friax offers the solution to remain constantly connected to your cellar. Using the **KWSP-I** kit, you connect to the supervision of your home through a Modbus protocol. The KWSP-III solution allows you to obtain all the essential information about the cellar for life using a tablet or smartphone.

Sustainable design

To participate in the effort to protect our planet, the MPCJ range uses the most modern and energy efficient ventilation technologies. The charge of refrigerant R290 in the refrigeration circuit reduces the impact of the air conditioner on global warming.



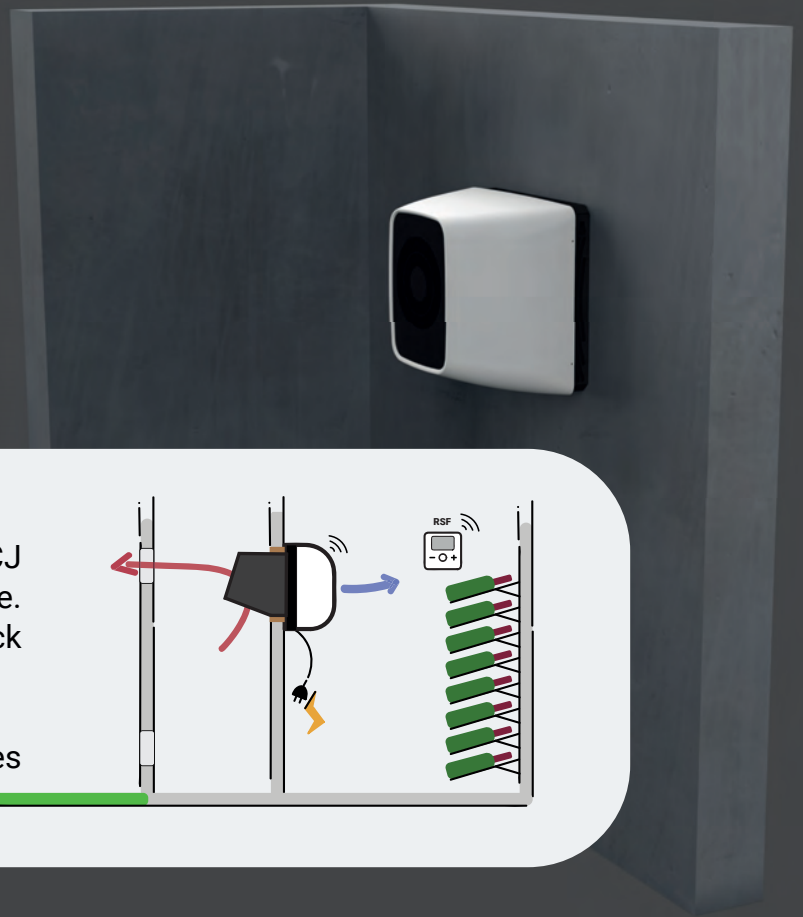

Easy to use

Installation, use or maintenance, MPCJ monoblocs are designed to be simple. Technical access is facilitated by quick dismantling.

Friax Industrie expertise guarantees that your wines will be well kept!

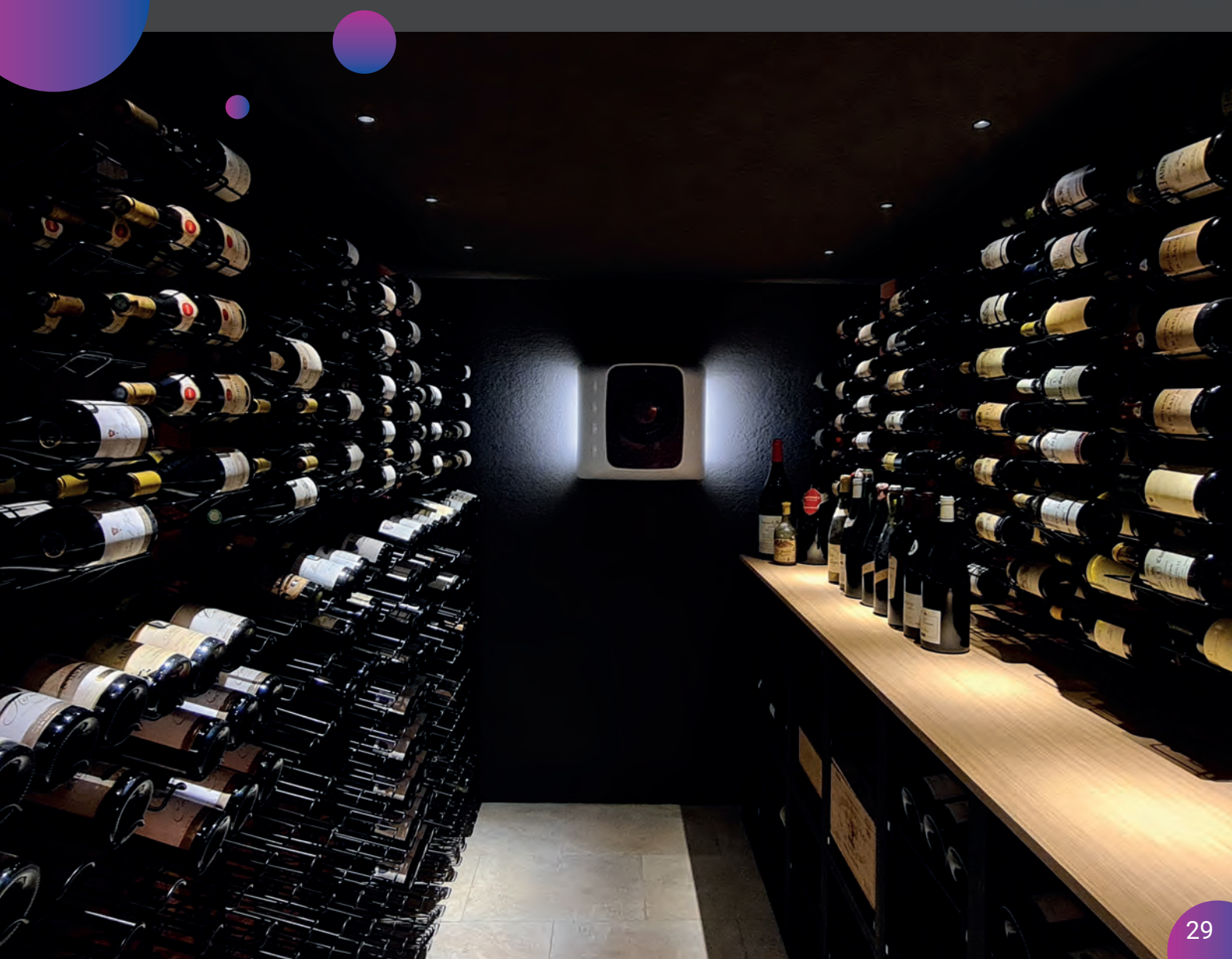
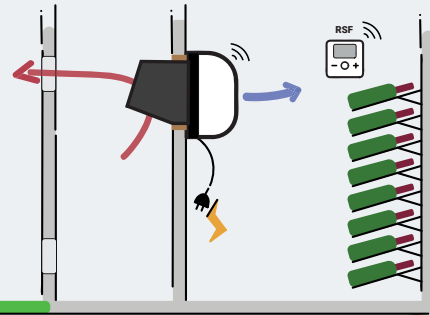

WINDOW MPCJ - Description

Vintage

Cooling – Heating – Humidification

- Mounting through the wall
- Cellar side white ABS body
- Customizable front
- Black epoxy paint body
- Condensate drain
- **CWR** (Cold water recycling)
- Front panel operation and alarm indicators
- Power cord
- Variable speed **EC** low consumption fans
- **KPC** Condensing pressure control
- **RC** Heating belt on compressor (Winter Kit) with energy saving program
- **RSF2** white wireless radio remote control
- Display of temperature, humidity, and various functions of the device
- **KCH** integrated heating function
- **KHGR%** Integrated humidifier
- Wall mounting frame
- R290 fluid with no impact on the environment

Dimensions

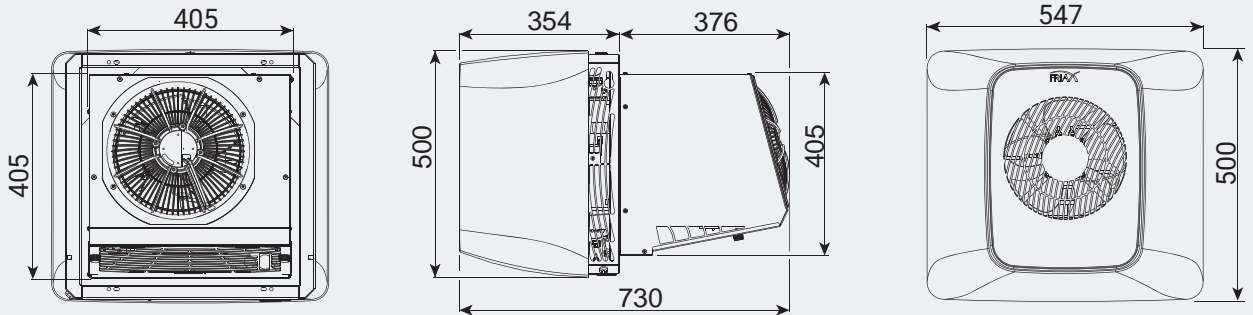

MPCJ Wall mounting frame

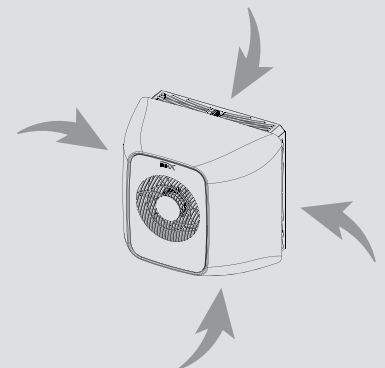
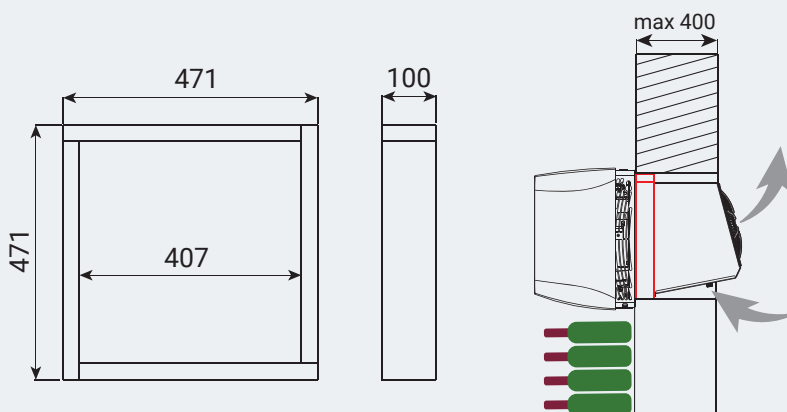

The MPCJ must be installed far enough from obstacles to allow air intake on its periphery.

WINDOW MPCJ

Technical characteristics

	MPCJ	30	48
Cooling capacity 12°C / 32°C ext.	W	780	1100
Heating capacity	W	800	800
	MPCJ	30	48
Voltage	50Hz	230 V/1+T	230 V/1+T
Max cooling Intensity absorbed	A	4.11	5.11
Max heating Intensity absorbed	A	3.9	3.9
Air flow in the cellar	m3/h	452	442
Sound pressure level at 5m	db	37	45
Net weight	kg	38	40
Body color		White / Black	White / Black
Refrigerant		R290	R290









Monobloc MPCJ Vintage

Item code

MPCJ30_VT

MPCJ48_VT

Customization

Code	Description	Compatibility	Infos
 KFXJ-CEDRE	Cedar Wood color custom front	X	p65
 KFXJ-ROUGE	Lipstick Red color custom front	X	p65
 KFXJ-BLEU	Intense Blue color custom front	X	p65
 KFXJ-GP	Polar Grey color custom front	X	p65
 KFXJ-GLITTER	Black Glitter color custom front	X	p65
 KFXJ-CUIVRE	Brushed Copper color custom front	X	p65
 KFXJ-ARGENT	Brushed Silver color custom front	X	p65
 KFXJ-OV	Vintage Gold color custom front	X	p65
 KCXJ-NOIR	Black Night Matt color custom body	X	p65

Can't find what you are looking for? Ask us for a color or engraving to your image!

Accessories

Code	Description	Compatibility	Infos
		Vintage	
KLPWSECU-XJ	Secure connection kit for H20X and MPCJ humidifiers	X	p66
KLPR20	20m extension kit for humidifier	X	p66
KPR-X0	Lift pump kit for H20X0 - H20X - EVX0 - EVX - MPC0 - MPCJ	X	p66
KLED-XJ	Plug&play LED kit for H20X - EVX2 - MPCJ	X	p65
KWSP-I	WineSupervisor I Kit - Modbus version	X	p65
KWSP-III	WineSupervisor III Kit - Connected version	X	p65
KNET125	Odorless fungicide bactericide cleaning spray 125 ml cellar air conditioning	X	p65



1 Adding a WineSupervisor3 kit allows you to take remote control and monitor proper operation from the internet.



Quick selection

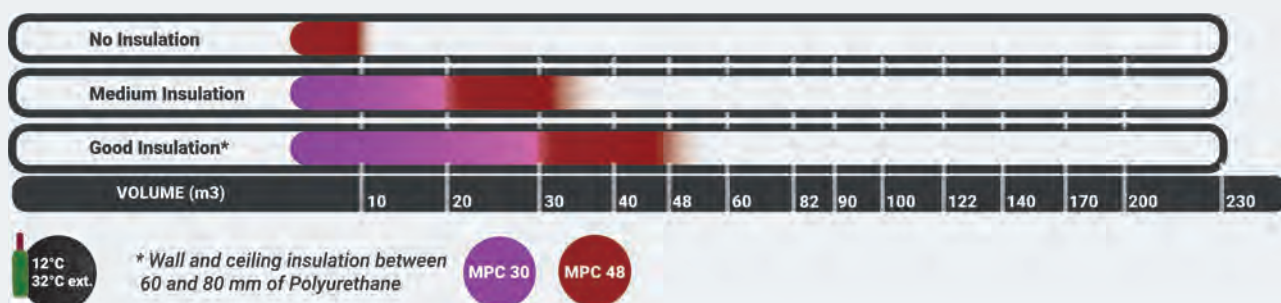

WARNING

The selections are only indicative and cannot replace a thermal balance that will consider all the parameters related to the cellar.



Monoblocs MPCG multiply the installation solutions during assembly.

Equipped as standard with a **KFG** ductable front kit, these devices can be positioned through the wall, as well as inside or outside the volume to be air-conditioned to bypass space constraints.

Group and evaporator can be ducted separately or simultaneously with the addition of an additional **KFG** kit.

The installation of an **MPCG** for the air conditioning of a cellar **overcomes the constraints related to the refrigeration connections** of the split systems.

Vintage finish



The Vintage appellation makes it possible to maintain a healthy cellar with air conditioning and heating regulation to limit temperature differences between seasons and best protect the wine. Vintage also incorporates the **KHGR%** humidification system. Connected to the city water network, it allows the humidity to be brought to the required value (ideally 65 -75%). No heat input, softened or demineralized water is not necessary.

The use of a KLPWSECU kit will facilitate and secure its connection.

Remote control RSF2 new generation



This is the simplest solution to take control of your cellar conditioner. With the wireless radio frequency remote control **RSF2**, no more distance problem, the signal passes through walls. You can control your cellar right up to your kitchen. On Vintage models, it displays temperature and humidity.



WineSupervisor



This is the connected solution. Whatever your environment, Friax offers the solution to remain constantly connected to your cellar. Using the **KWSP-I** kit, you connect to the supervision of your home through a Modbus protocol. The KWSP-III solution allows you to obtain all the essential information about the cellar for life using a tablet or smartphone.

Sustainable design



To participate in the effort to protect our planet, the **MPCG** uses the most modern and energy efficient ventilation technologies. The charge of refrigerant R290 in the refrigeration circuit reduces the impact of the air conditioner on global warming.

DUCTABLE MPCG - Description

Vintage

Colling - Heating - Humidification

- Mounting through the wall
- Black epoxy paint body
- KFG ducting kit and glossy black front
- Condensate drain on the front
- **CWR** (Cold water recycling)
- Front panel operation and alarm indicators
- Power cord with power switch
- Variable speed **EC** low consumption fans
- **KPC** Condensing pressure control
- **RC** Heating belt on compressor (Winter Kit) with energy saving program
- **RSF** wireless remote control
- Display of the temperature and the various functions of the device
- **KCH** integrated heating function
- **KHGR%** Integrated humidifier
- **R290** fluid with no impact on global warming

Dimensions

Monoblocs MPCG 30 and 48 | Mounting IN

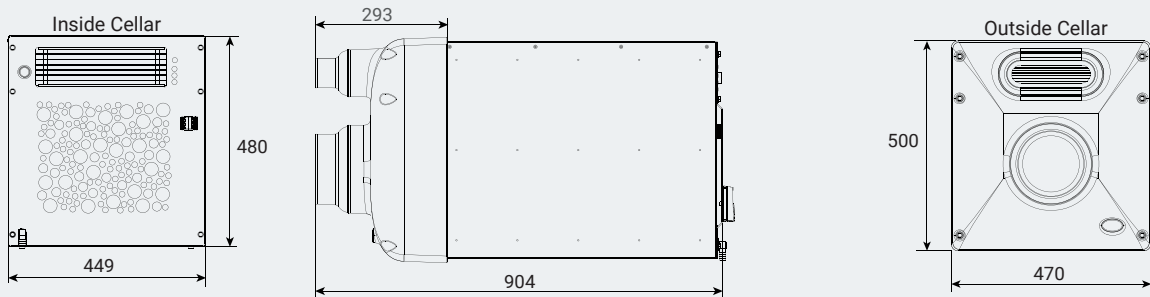

Monoblocs MPCG 30 and 48 | Mounting OUT

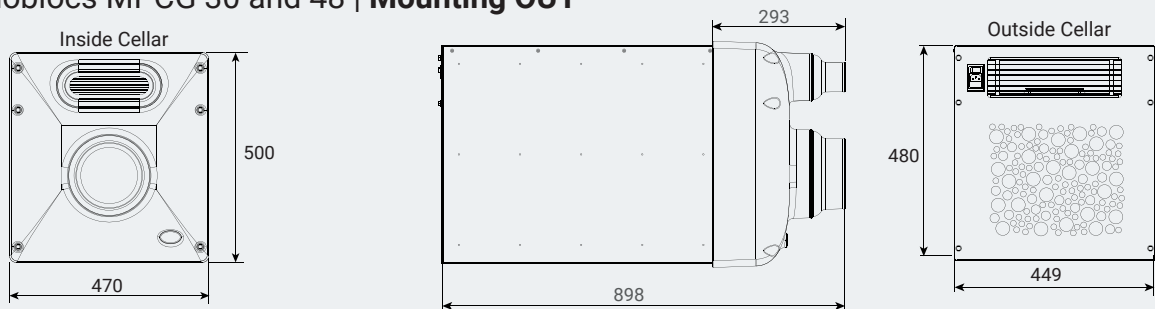

Monoblocs MPCG 30 and 48 | Mounting IN / OUT

(requires additional KFG30-48 kit)

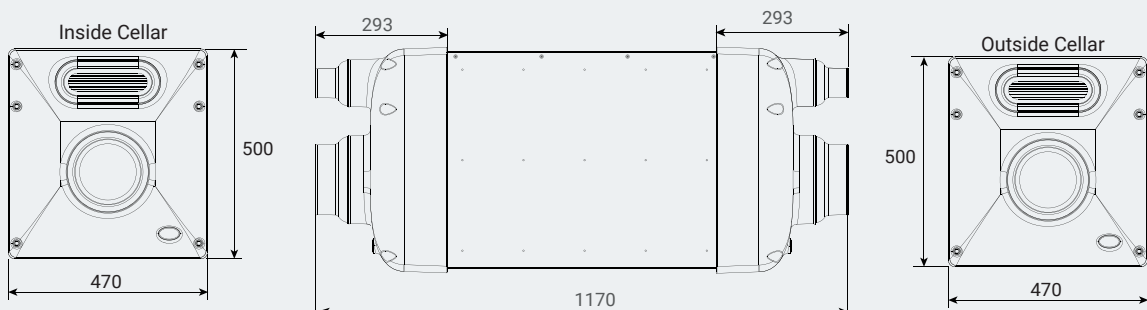

DUCTABLE MPCG

Technical characteristics

	MPCG	30	48
Cooling capacity 12°C / 32°C ext.	W	780	1100
Heating capacity	W	800	800
	MPCG	30	48
Voltage	50Hz	230V/1+T	230V/1+T
Max cooling Intensity absorbed	A max	4	5
Max heating Intensity absorbed	A max	4.4	4.4
	MPCG	30	48
Air flow in the cellar	m3/h	310	365
Sound pressure level at 5m	db	37	45
Condensing unit air flow	m3/h	405	510
Net weight	kg	45	49
Body color		Black	Black
Refrigerant		R290	R290

Monobloc MPCG Vintage	Item code	MPCG30_VT	MPCG48_VT
-----------------------	-----------	-----------	-----------

Accessories

Code	Description	Compatibility	Infos
		Vintage	
KLPWSECU	Secure connection kit for humidifier	X	p66
KLPR20	20m extension kit for humidifier	X	p66
KPR	Lift pump kit	X	p66
KWSP-I	WineSupervisor I - Kit Modbus version	X	p65
KWSP-III	WineSupervisor III - Kit Connected version	X	p65
KFG30-48	Ductable Front Kit for MPCG	X	p67
KS2M	Wall Mounting Kit	X	p67
KNET125	Odorless fungicide bactericide cleaning spray 125 ml cellar air conditioning	X	p66

All the ducting kits are available p.59 of your catalog

1 Adding a WineSupervisor3 kit allows you to take remote control and monitor proper operation from the internet.

Quick selection

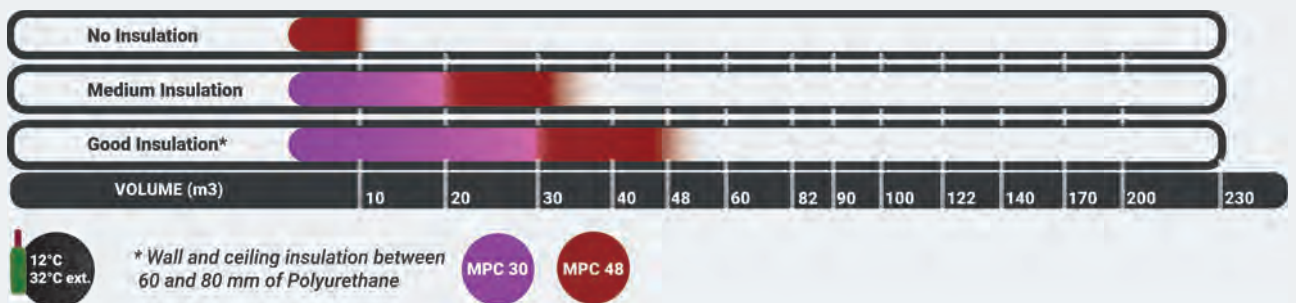

WARNING

The selections are only indicative and cannot replace a thermal balance that will consider all the parameters related to the cellar.

CABINET MPCA**The monobloc for wine cabinet integration.**

The integration capability of the **MPCA** range gives you the freedom to create your very own custom cellar.

You can display your wines in a single or multi-temperature cabinet at controlled humidity and this in absolute silence ...

Céos Finish

This is the most complete solution on the **MPCA**. It provides the air conditioning and humidification functions of the cellar. Optimized for cellars and cabinets that are too dry, these models are equipped with the **HGR%** system. It allows humidity to be raised without heat input and does not require demineralized water or a softener. Using a **KLPWSECU** kit will facilitate and secure the connection to the water. No need to connect a drain, the condensation water will be evaporated by the dual evaporation system integrated into the device.

Remote control RSF2 new generation

This is the simplest solution to take control of your cellar conditioner. With the wireless radio frequency remote control **RSF2**, no more distance problem, the signal passes through walls. You can control your cellar right up to your kitchen. On Céos models, it displays temperature and humidity.

**WineSupervisor**

This is the connected solution. Whatever your environment, Frax offers the solution to remain constantly connected to your cellar. Using the **KWSP-I** kit, you connect to the supervision of your home through a Modbus protocol. The **KWSP-III** solution allows you to obtain all the essential information about the cellar for life using a tablet or smartphone.

Sustainable design

To participate in the effort to protect our planet, the **MPCG** uses the most modern and energy efficient ventilation technologies. The charge of refrigerant R290 in the refrigeration circuit reduces the impact of the air conditioner on global warming.

CABINET MPCA - Installation Possibilities

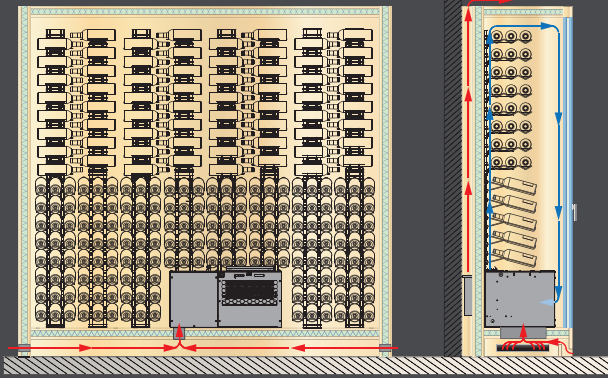

MPCA 30 CC Céos Up

AIR BLOWING UP

Used for cabinets standing against a wall. The air conditioning is forced behind the bottle holders to gently stir the atmosphere in the cellar. The ventilation of

the condensing unit is done by sucking in the air from the underside of the cabinet and exhausting it from the rear side against the wall.

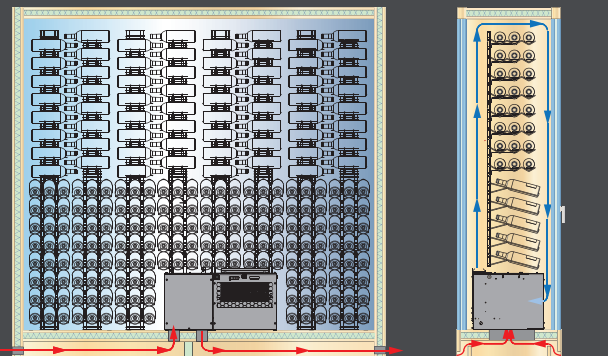

MPCA 30 CC Céos Down

AIR BLOWING DOWN

For showcases cabinet positioned as an island or as a separation of two spaces with 2, 3 or 4 glass sides. The air conditioning is forced behind the bottle storage and

is then sucked in through the front of the monobloc. The ventilation of the condensing unit is done by sucking the air from the underside of the cabinet. The hot air is exhausted downwards in the opposite direction opposite (requires adjustment).



For all models the cabinet lighting can be operated by the air conditioner wireless remote control. All CC models are equipped with a double condensate evaporation system. Connection to a drain is still possible.

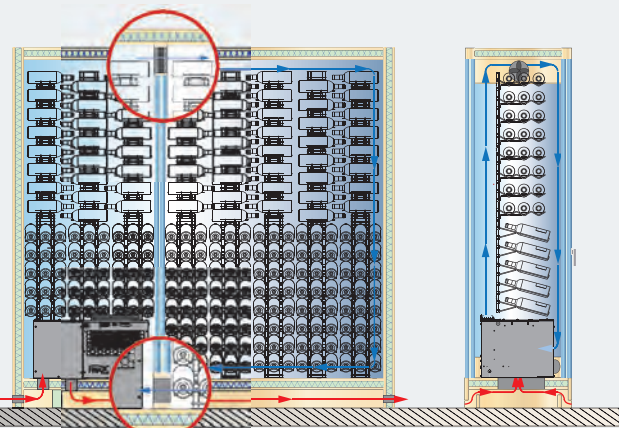

MPCA 30 CC Céos Down + Kit KB2T-SPLIT

MULTI-ZONE REGULATION

The MPCA with the **KB2T-SPLIT** kit makes it possible to combine in the same cabinet a day cellar for the cooling of white wines and Champagnes (+ 6 ° C) and to control a second zone

in the service cellar for red wines (+ 16 ° C) or in a aging cellar (+ 12 ° C) for all wines.

In this configuration, the MPCA is placed in the coldest zone. The **KB2T-SPLIT** bi-temperature control kit provides temperature management by circulating air from the coldest zone to the hottest zone.



CABINET MPCA - Description

Céos

Cooling - Humidification

- Installation through the wall / cabinet
- Black epoxy paint body
- **CWR** (Cold water recycling)
- Front panel operation and alarm indicators
- Power switch
- Variable speed **EC** low consumption fans
- **KPC** Condensing pressure control
- **RSF2** wireless radio remote control
- Display of the temperature and the various functions of the device
- **KHGR%** Integrated humidifier
- CC condensate drain (hot + electric)
- R290 fluid with no impact on global warming

Custom cabinet configurations

MPCA 20				MPCA 30			
	2 x 600 mm doors 4 glass sides	2 x 600 mm doors 3 glass sides 2 temperatures	3 x 600 mm doors 3 glass sides		2 x 800 mm doors 4 glass sides	3 x 800 mm doors 3 glass sides	3 x 800 mm doors 1 glass sides 2 temperatures

ACCESSORY ZOOM



When choosing the UP solution, the **KRH** insulated extension kit avoids the creation of a plinth by raising the MPCA to facilitate air circulation under the group.



Dimensions

MPCA Monobloc 20 and 30 AIR BLOWING UP

KRH-MPCA20-U
OR
KRH-MPCA30-U

MPCA Monobloc 20 and 30 AIR BLOWING DOWN

	MPCA 20	MPCA 30
A	578	719

CABINET MPCA

Technical characteristics

	MPCA	20	30	
Cooling capacity +6°C / +12°C 28°C ext	W	460/680	620/800	
Temperature setting	°C	6 -16	6 -16	
	MPCA	20	30	
Voltage	50Hz	230V/1+T	230V/1+T	
Intensity absorbed	A max	5	5.8	
	MPCA	20	30	
Air flow in the cellar	m3/h	210	240	
External environment temperature	C°	28	28	
Outlet Air flow	m3/h	250	320	
Net weight	kg	45	47	
Body color		Black	Black	
Refrigerant		R290	R290	
Monobloc MPCA Céos UP - Condenser blowing air up		<i>Item code</i>	MPCA20_CC_CS_U	MPCA30_CC_CS_U
Monobloc MPCA Céos DOWN - Condenser blowing air down		<i>Item code</i>	MPCA20_CC_CS_D	MPCA30_CC_CS_D

Accessories

Code	Description	Compatibility		Infos
		Céos		
KLPWSECU	Secure connection kit for humidifier	X		p66
KLPR20	20m extension kit for humidifier	X		p66
KB2T-SPLIT	Bi-Temperature ventilation kit for multi-zone cabinet	X		p68
KRH-MPCA20-U	MPCA 20 UP extension kit for rear air intake	X		p67
KRH-MPCA30-U	MPCA 30 UP extension kit for rear air intake	X		p67
PR60010256	ABS Duct 90° Horizontal Bend (60x200)	X		p68
PR60010257	ABS Duct 1m length (60x200)	X		p68
PR60010261	ABS Duct Flange (60x200)	X		p68
PR60010263	ABS Duct 90° Vertical Bend (60x200)	X		p68
KWSP-I	WineSupervisor I Kit - Modbus version	X		p65
KWSP-III	WineSupervisor III - Kit Connected version	X		p65
KNET125	Odorless fungicide bactericide cleaning spray 125 ml cellar air conditioning	X		p66

1 Adding a WineSupervisor3 kit allows you to take remote control and monitor proper operation from the internet.



To go even further | Custom cellar spaces

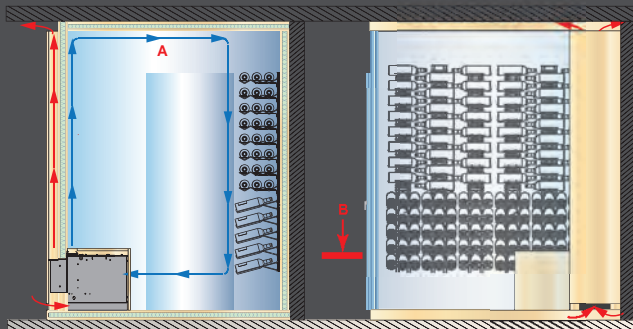

Installing an air-conditioned cellar space in a living room or a leisure room becomes relatively simple with the MPCA. Placed on a **KRH-...** riser in the room, it plugs into a power outlet.

A **KLPWSECU** kit will allow easy connection of the humidifier of the Céos models. No emptying to be expected. Quietly, in a perfectly controlled atmosphere, your wines will be protected for a long time.

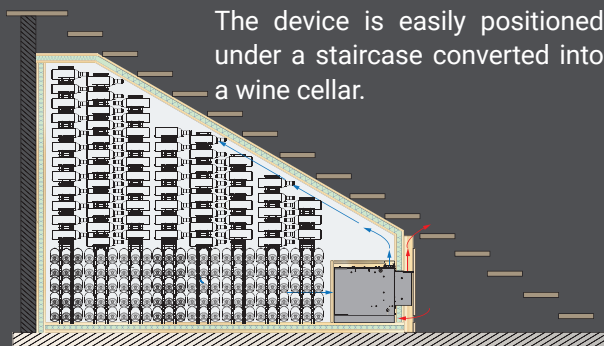
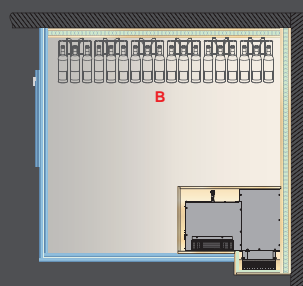

The device is easily positioned under a staircase converted into a wine cellar.



YOUR DISTRIBUTOR

RANGE 20 years

Cover photo

Cave Le Mas les Eydins by Alexandra and Christophe Bacquié - 84 Bonnieux - France

VisioRack cellar storage by Friax

SPC 82 EVA Vintage air conditioner

231 / 233 Rue de la Prairie
73420 Voglans – FRANCE

www.friax.fr

+33 (0)4 79 34 91 84
info@friax.fr